

Date of application  
**Mar. 11. 2014**

NICHICON CORPORATION  
NICHICON (OHNO) CORPORATION  
DESIGN DEPT. I

**S P E C I F I C A T I O N**  
**O F**  
**ALUMINUM ELECTROLYTIC CAPACITORS**

**UCY2W810AHDAZX**

---

DWG. No.	<b>H140311h3</b>	CHECKED	<b>K.Yasukawa Mar. 11. 2014</b>
DESIGNED.	<b>K.Kominami Mar. 11. 2014</b>	APPROVED	<b>J.Kobayashi Mar. 11. 2014</b>

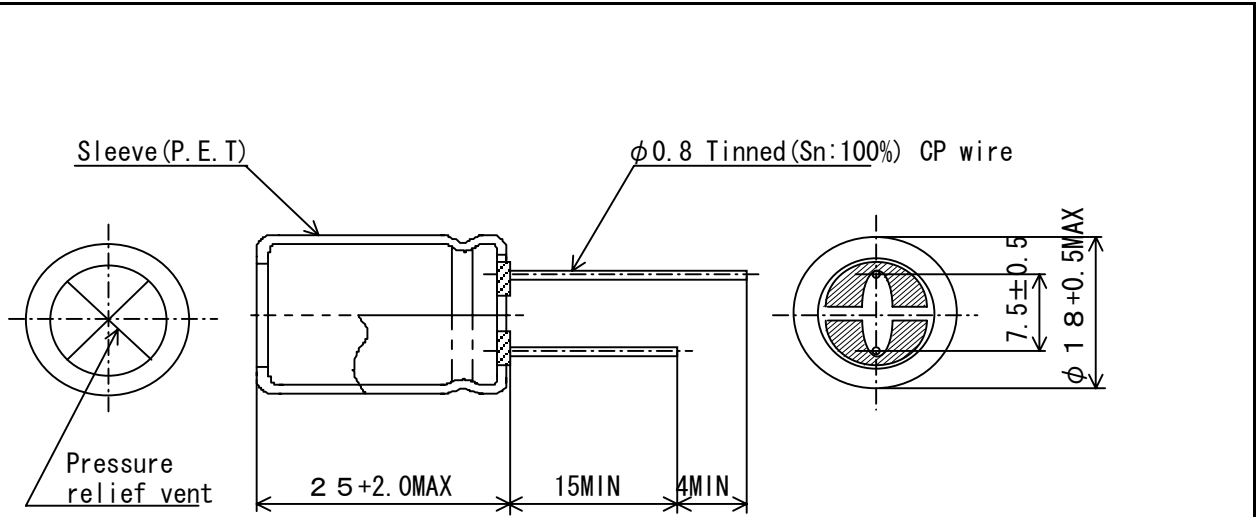

<Example>

**nichicon**  
81  $\mu$ F 450V  
CY  
105°C  
Lot. No.

**nichicon**  
81  $\mu$ F 450V  
CY  
105°C  
Lot. No.  
PET

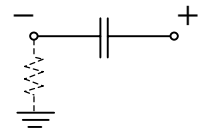

CONNECTION DIAGRAM

Sleeve color: Dark Brown  
Marking color: White

## ELECTRICAL CHARACTERISTICS

WORKING VOLTAGE (V. D. C)	SURGE VOLTAGE (V. D. C)	RATED CAP ( $\mu$ F)	CAP. TOL. (%)	$\tan \delta$ (MAX)	LEAKAGE CURRENT ( $\mu$ A MAX)	RIPPLE CURRENT (mA rms MAX)	
450	500	81	$\pm 25$	0.24	1558	560	
at 120Hz 20 °C					450 V	at 120Hz 105°C	
					20°C after 1min		

TEST STANDARD

JIS C 5101-4

OPERATING TEMP. RANGE

-25 ~ 105°C

				NICHICON TYPE NO.			
				<b>UCY2W810AHDZAX</b>			
				RATE			
				450V		81 $\mu$ F	
3RD ANGLE PROJEC-		SCALE /mm		DATE		CASE SIZE	
MARK		DATE		2014/3/11		<b>φ18 × 25 L</b>	
DESCRIPTIONS		APPR.		TION			
REVISION :							
SPECIFICATION				DWG. No.		<b>H140311h3</b>	
						sheet	<b>2</b>

## SPECIFICATION ALUMINUM ELECTROLYTIC CAPACITOR

1. SCOPE  
This specification covers polarized aluminum foil drytype electrolytic capacitors.  
( JIS-04 TYPE)
2. APPLICABLE SPECIFICATION  
Japanese Industrial Standard JIS C 5101-4:1998 Characteristics W and  
JIS C-5101-1:1998 except as specified in this specification.
3. PERFORMANCE  
Unless otherwise specified, the standard range of atmospheric conditions  
for making measurements and tests is as follows :  
 Ambient temperature : 5 to 35°C  
 Relative humidity : 45 to 85%RH  
 Air pressure : 86kPa to 106kPa  
 If there may be any doubt on the results, measurements shall be made within the  
 following limits,  
 Ambient temperature : 20±2°C  
 Relative humidity : 60 to 70%RH  
 Air pressure : 86kPa to 106kPa

No.	Item	Test method	Performance
3.1	OPERATING TEMPERATURE RANGE		-25 ~ 105 °C
3.2	RATED VOLTAGE		450 V
3.3	CAPACITANCE	at 120Hz±20%	81 μF±25%
3.4	tan δ	at 120Hz±20% To comply with JIS C 5101-1 4.8	0.24 MAX.
3.5	LEAKAGE CURRENT	To comply with JIS C 5101-1 4.9 After 1 minute's application of rated voltage.(at 20°C)	1558 μA MAX.
3.6	SURGE VOLTAGE	To comply with JIS C 5101-1 4.26 The surge voltage specified in the individual standard shall be applied 1000 times, each for 30±5s, period of 6±0.5min. Electric discharge : Not to carry Out Test temperature : 15~35°C	Capacitance : Not less than 80 % of the value before test. tan δ : Not more than 200 % of the specified value. Leakage current : Initial specified value or less
3.7	IMPEDANCE RATIO AT LOW TEMPERATURE	To comply with JIS C 5101-1 4.10 -25 ± 0.5 °C 2h Measurement frequency : 120Hz±20%	$ Z _{-25°C}/ Z _{20°C} \leq 6$
3.8	TERMINAL STRENGTH	To comply with JIS C 5101-1 4.13 Tensile strength of termination : tensile force holding time tensile force : 10 N Bending strength of termination : Count it as 2 times. Dead weight : 5 N	No abnormality such as cutting off, looseness or the like of termination.
3.9	SOLDERABILITY	To comply with JIS C 5101-1 4.15 Temperature of solder : 235±5°C Dipping time : 2±0.5 s Storage time : after 6 month	At least 3/4 of circumferential surface of the dipped portion of termination shall be covered with new solder.
3.10	RESISTANCE OF SOLDERING	To comply with JIS C 5101-1 4.14 Temp. : 260±5°C Time : 10±1s or Temp. : 350 ±10°C Time : 3 ± 0.5 s	Capacitance change : Within ±10% of initial value tan δ : Initial specified value or less. Leakage current : Initial specified value or less. Appearance : No remarkable abnormality.

No.	Item	Test method	Performance
3.11	RESISTANCE TO DAMP HEAT (STEADY STATE)	To comply with JIS C 5101-1 4.22 Test temperature : 40±2°C Relative humidity : 90~95%RH Test time : 240±8h	Capacitance change : Within ±15% of initial value tanδ : Initial specified value or less. Leakage current : Initial specified value or less. Appearance : No remarkable abnormality.
3.12	ENDURANCE	To comply with JIS C 5101-1 4.23 Test temperature : 105±2°C Test time : 10000 <sup>+2</sup> <sub>-3</sub> h  D.C. bias with rated ripple current so that its peak voltage shall not exceed the rated D.C. voltage.	Capacitance change : Within ±20 % of initial value tanδ : 200 % or less of initial specified value. Leakage current : Initial specified value or less. Appearance : No remarkable abnormality.
3.13	SHELF LIFE TEST	Test temperature : 105±2°C Test time : 1000 <sup>+8</sup> <sub>-3</sub> h	Capacitance change : Within ±20 % of initial value tanδ : 200 % or less of initial specified value. Leakage current : Initial specified value or less. ( Voltage treatment according to JIS C 5101-4 4.1 ) Appearance : No remarkable abnormality.
3.14	RESISTANCE TO VIBRATION	To comply with JIS C 5101-1 4.17 Direction and duration of vibration : 3 orthogonal directions mutually directions mutually each for 2h Total 6 h Frequency : 10 to 55 Hz Reciprocation for 1 min. Total amplitude : 1.5 mm	Capacitance : When the capacitance is measured, there shall be no intermittent contacts, or open or short-circuiting, and no abnormality. Appearance : No remarkable abnormality.
3.15	PRESSURE RELIEF VENT TEST	A.C Application Test The capacitor shall be subjected to an A.C. voltage (50 to 60Hz) with r.m.s value equal to 0.7 times the rated D.C. voltage through a series resistor. The series resistor as follows. R = 10 Ω  D.C Application Test The capacitor shall be subjected to a reverse D.C. voltage equal to the rated D.C. voltage. the current flowing through the capacitor shall be limited to 1A.	There is no fine of the capacitor, when the pressure relief device shall be open, or there is no explosion or fire, etc. of the capacitor when 30 minutes has elapsed from the start of the test.
		NOTE : The test is terminated if the vent device is not conducted under the condition.	

#### 4. MARKING

- Capacitors shall be legibly marked with following.  
The marking "PET" shall be marked on sleeve in case.
- 4-1 Manufacture's Trade mark
  - 4-2 Rated voltage
  - 4-3 Nominal capacitance
  - 4-4 EIA DATE CODE
  - 4-5 Negative polarity
  - 4-6 Capacitance Tolerance
  - 4-7 Maximum operating temperature identification
  - 4-8 Series identification

## 5. OTHERS

- The Relevant Export Regulation Laws:  
In case that there is a certain danger of the products conflicting with the use and activity for the developments of weapons of mass destruction, the procedures based upon the relevant export regulation laws are absolutely needed.
  
- Ozone Depletion Substance  
Ozone depletion substances are not used in our production process and at our suppliers.
  
- Brominated Flame Retardants  
The restricted brominated flame retardants are not used.
  
- Please note that calculated lifetime is for reference only and not guaranteed.
  
- Production factory  
NICHICON (OHNO) CORPORATION  
NICHICON (IWATE) CORPORATION  
NICHICON (MALAYSIA) SDN. BHD.  
NICHICON ELECTRONICS (WUXI) CO., LTD.

## X-ON Electronics

Largest Supplier of Electrical and Electronic Components

*Click to view similar products for [Aluminum Electrolytic Capacitors - Leaded](#) category:*

*Click to view products by [Nichicon](#) manufacturer:*

Other Similar products are found below :

[LXY50VB4.7M-5X11](#) [MAL203125221E3](#) [MAL204216159E3](#) [ESMG101ETD100MF11S](#) [RBC-25V-10UF-4X7](#) [RE3-35V222MJ6#](#) [RFO-100V471MJ7P#](#) [B41041A2687M8](#) [B41041A7226M8](#) [B41044A7157M6](#) [EKRG250ELL100MD07D](#) [EKXG201EC3101ML20S](#)  
[EKXG351ETD6R8MJ16S](#) [EKZM160ETD471MHB5D](#) [EPA-201ELL151MM25S](#) [NCD681K10KVY5PF](#) [NRLF103M25V35X20F](#)  
[KM4700/16](#) [KME50VB100M-8X11.5](#) [RXJ222M1EBK-1625](#) [SG220M1CSA-0407](#) [ES5107M016AE1DA](#) [ESX472M16B](#) [MAL211929479E3](#)  
[40D506F050DF5A](#) [TE1202E](#) [36DA273F050BB2A](#) [KME25VB100M-6.3X11](#) [511D336M250EK5D](#) [511D337M035CG4D](#)  
[515D477M035CG8PE3](#) [052687X](#) [EKMA500ELL4R7ME07D](#) [EKRG100ETC221MF09D](#) [NRE-S560M16V6.3X7TBSTF](#)  
[ERZA630VHN182UP54N](#) [MAL214099813E3](#) [MAL211990518E3](#) [MAL204281229E3](#) [NEV680M35EF](#) [686KXM050M](#) [ERS1VM222L30OT](#)  
[EGW2GM150W16OT](#) [EGS2GM6R8G12OC](#) [EHS2GM220W20OT](#) [ERF1VM222L30OT](#) [ERF1KM151G20OT](#) [EKZE500ELL101MHB5D](#)  
[EKMM251VSN221MP25S](#) [RGA221M1HBK-1016G](#)