

UWX

5.5mmL Chip Type



For SMD



Anti-Solvent Feature

- Chip type with 5.5mm height.
- Designed for surface mounting on high density PC board.
- Applicable to automatic mounting machine fed with carrier tape.
- Load life of 2000 hours at 85°C.
- Compliant to the RoHS directive (2011/65/EU,(EU)2015/863).
- AEC-Q200 compliant. Please contact us for details.

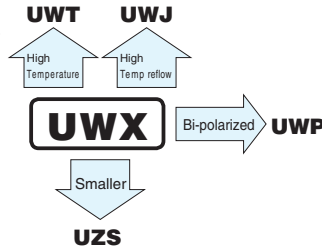

Specifications

Item	Performance Characteristics																											
Category Temperature Range	-40 to +85°C																											
Rated Voltage Range	4 to 50V																											
Rated Capacitance Range	1 to 330μF																											
Capacitance Tolerance	±20% at 120Hz, 20°C																											
Leakage Current	After 2 minutes' application of rated voltage at 20°C, leakage current is not more than 0.01CV or 3 (μA), whichever is greater.																											
Tangent of loss angle (tan δ)	<table border="1"> <thead> <tr> <th>Rated voltage (V)</th> <th>4</th> <th>6.3</th> <th>10</th> <th>16</th> <th>25</th> <th>35</th> <th>50</th> </tr> </thead> <tbody> <tr> <td>tan δ (MAX.)</td> <td>0.35 (0.40)</td> <td>0.26 (0.30)</td> <td>0.20 (0.24)</td> <td>0.16 (0.19)</td> <td>0.14 (0.16)</td> <td>0.12 (0.14)</td> <td>0.12 (0.14)</td> </tr> </tbody> </table> <p>Values in () applicable to WR.</p>	Rated voltage (V)	4	6.3	10	16	25	35	50	tan δ (MAX.)	0.35 (0.40)	0.26 (0.30)	0.20 (0.24)	0.16 (0.19)	0.14 (0.16)	0.12 (0.14)	0.12 (0.14)											
Rated voltage (V)	4	6.3	10	16	25	35	50																					
tan δ (MAX.)	0.35 (0.40)	0.26 (0.30)	0.20 (0.24)	0.16 (0.19)	0.14 (0.16)	0.12 (0.14)	0.12 (0.14)																					
Stability at Low Temperature	<table border="1"> <thead> <tr> <th colspan="2">Rated voltage (V)</th> <th>4</th> <th>6.3</th> <th>10</th> <th>16</th> <th>25</th> <th>35</th> <th>50</th> </tr> </thead> <tbody> <tr> <td>Impedance ratio</td> <td>Z_{-25°C} / Z_{+20°C}</td> <td>7</td> <td>4</td> <td>3</td> <td>2</td> <td>2</td> <td>2</td> <td>2</td> </tr> <tr> <td></td> <td>Z_{-40°C} / Z_{+20°C}</td> <td>15</td> <td>8</td> <td>8</td> <td>4</td> <td>4</td> <td>3</td> <td>3</td> </tr> </tbody> </table>	Rated voltage (V)		4	6.3	10	16	25	35	50	Impedance ratio	Z _{-25°C} / Z _{+20°C}	7	4	3	2	2	2	2		Z _{-40°C} / Z _{+20°C}	15	8	8	4	4	3	3
Rated voltage (V)		4	6.3	10	16	25	35	50																				
Impedance ratio	Z _{-25°C} / Z _{+20°C}	7	4	3	2	2	2	2																				
	Z _{-40°C} / Z _{+20°C}	15	8	8	4	4	3	3																				
Endurance	<p>The specifications listed at right shall be met when the capacitors are restored to 20°C after the rated voltage is applied for 2000 hours at 85°C.</p> <table border="1"> <tbody> <tr> <td>Capacitance change</td> <td>Within ±20% of the initial capacitance value (Within ±25% for 4 V and WR series units)</td> </tr> <tr> <td>tan δ</td> <td>200% or less than the initial specified value</td> </tr> <tr> <td>Leakage Current</td> <td>Less than or equal to the initial specified value</td> </tr> </tbody> </table>	Capacitance change	Within ±20% of the initial capacitance value (Within ±25% for 4 V and WR series units)	tan δ	200% or less than the initial specified value	Leakage Current	Less than or equal to the initial specified value																					
Capacitance change	Within ±20% of the initial capacitance value (Within ±25% for 4 V and WR series units)																											
tan δ	200% or less than the initial specified value																											
Leakage Current	Less than or equal to the initial specified value																											
Shelf Life	After storing the capacitors under no load at 85°C for 1000 hours and then performing voltage treatment based on JIS C 5101-4 clause 4.1 at 20°C, they shall meet the specified values for the endurance characteristics listed above.																											
Resistance to soldering heat	<p>The capacitors are kept on a hot plate for 30 seconds, which is maintained at 250°C. The capacitors shall meet the characteristic requirements listed at right when they are removed from the plate and restored to 20°C.</p> <table border="1"> <tbody> <tr> <td>Capacitance change</td> <td>Within ±10% of the initial capacitance value</td> </tr> <tr> <td>tan δ</td> <td>Less than or equal to the initial specified value</td> </tr> <tr> <td>Leakage current</td> <td>Less than or equal to the initial specified value</td> </tr> </tbody> </table>	Capacitance change	Within ±10% of the initial capacitance value	tan δ	Less than or equal to the initial specified value	Leakage current	Less than or equal to the initial specified value																					
Capacitance change	Within ±10% of the initial capacitance value																											
tan δ	Less than or equal to the initial specified value																											
Leakage current	Less than or equal to the initial specified value																											
Marking	Black print on the case top.																											

Chip Type

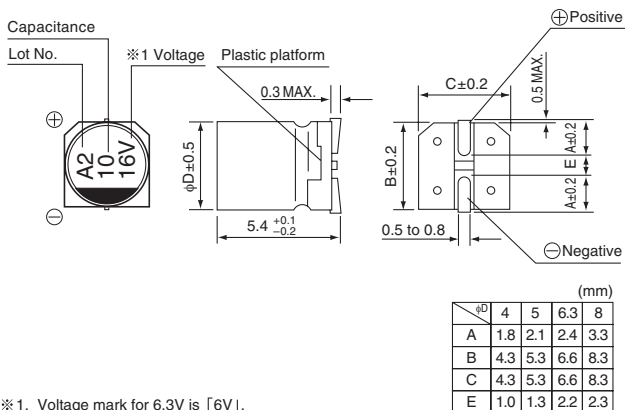

Type numbering system (Example : 16V 10μF)

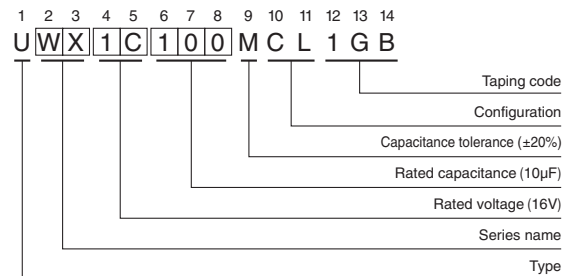

Frequency coefficient of rated ripple current

Frequency	50 Hz	120 Hz	300 Hz	1 kHz	10 kHz or more
Coefficient	0.70	1.00	1.17	1.36	1.50

● Dimension table in next page.

UWX

■Dimensions

Rated Voltage (V) (code)	Rated Capacitance (μF)	Case Size φD×L (mm)	tan δ	Leakage Current (μA) (at 20°C after 2 minutes)	Rated Ripple (mArms) (85°C/120Hz)	Part Number
4 (0G)	33	4×5.4	0.35	3	28	UWX0G330MCL1GB
	47	4×5.4	0.35	3	33	UWX0G470MCL1GB
	56	5×5.4	0.35	3	42	UWX0G560MCL1GB
	100	5×5.4	0.35	4	56	UWX0G101MCL1GB
	150	6.3×5.4	0.35	6	79	UWX0G151MCL1GB
	220	6.3×5.4	0.35	8.8	96	UWX0G221MCL1GB
	330	8×5.4	0.35	13.2	145	UWX0G331MCL1GB
6.3 (0J)	22	4×5.4	0.26	3	28	UWX0J220MCL1GB
	33	5×5.4	0.26	3	37	UWX0J330MCL1GB
	33	4×5.4	0.30	3	34	UWR0J330MCL1GB
	47	5×5.4	0.26	3	45	UWX0J470MCL1GB
	47	4×5.4	0.30	3	40	UWR0J470MCL1GB
	56	6.3×5.4	0.26	3.528	52	UWX0J560MCL1GB
	56	5×5.4	0.30	3.528	46	UWR0J560MCL1GB
	100	6.3×5.4	0.26	6.3	70	UWX0J101MCL1GB
	100	5×5.4	0.30	6.3	47	UWR0J101MCL1GB
	150	6.3×5.4	0.26	9.45	71	UWX0J151MCL1GB
	220	8×5.4	0.26	13.86	110	UWX0J221MCL1GB
	220	6.3×5.4	0.30	13.86	74	UWR0J221MCL1GB
330	8×5.4	0.26	20.79	170	UWX0J331MCL1GB	
10 (1A)	22	5×5.4	0.20	3	33	UWX1A220MCL1GB
	22	4×5.4	0.24	3	30	UWR1A220MCL1GB
	33	5×5.4	0.20	3.3	41	UWX1A330MCL1GB
	33	4×5.4	0.24	3.3	34	UWR1A330MCL1GB
	47	6.3×5.4	0.20	4.7	52	UWX1A470MCL1GB
	47	5×5.4	0.24	4.7	47	UWR1A470MCL1GB
	56	6.3×5.4	0.20	5.6	57	UWX1A560MCL1GB
	56	5×5.4	0.24	5.6	50	UWR1A560MCL1GB
	100	6.3×5.4	0.20	10	76	UWX1A101MCL1GB
	100	5×5.4	0.24	10	54	UWR1A101MCL1GB
	150	8×5.4	0.20	15	111	UWX1A151MCL1GB
	150	6.3×5.4	0.24	15	76	UWR1A151MCL1GB
220	8×5.4	0.20	22	135	UWX1A221MCL1GB	
16 (1C)	10	4×5.4	0.16	3	23	UWX1C100MCL1GB
	22	5×5.4	0.16	3.52	37	UWX1C220MCL1GB
	22	4×5.4	0.19	3.52	30	UWR1C220MCL1GB
	33	6.3×5.4	0.16	5.28	49	UWX1C330MCL1GB
	33	5×5.4	0.19	5.28	44	UWR1C330MCL1GB
	47	6.3×5.4	0.16	7.52	58	UWX1C470MCL1GB
	47	5×5.4	0.19	7.52	52	UWR1C470MCL1GB
	56	6.3×5.4	0.16	8.96	63	UWX1C560MCL1GB
	56	5×5.4	0.19	8.96	57	UWR1C560MCL1GB
	100	6.3×5.4	0.16	16	86	UWX1C101MCL1GB

UWX

■ Dimensions

Rated Voltage (V) (code)	Rated Capacitance (μF)	Case Size φD×L (mm)	tan δ	Leakage Current (μA) (at 20°C after 2 minutes)	Rated Ripple (mArms) (85°C/120Hz)	Part Number
25 (1E)	4.7	4×5.4	0.14	3	16	UWX1E4R7MCL1GB
	10	5×5.4	0.14	3	27	UWX1E100MCL1GB
	10	4×5.4	0.16	3	24	UWR1E100MCL1GB
	22	6.3×5.4	0.14	5.5	42	UWX1E220MCL1GB
	22	5×5.4	0.16	5.5	38	UWR1E220MCL1GB
	33	6.3×5.4	0.14	8.25	52	UWX1E330MCL1GB
	33	5×5.4	0.16	8.25	46	UWR1E330MCL1GB
	47	8×5.4	0.14	11.75	70	UWX1E470MCL1GB
	47	6.3×5.4	0.16	11.75	60	UWR1E470MCL1GB
	56	8×5.4	0.14	14	76	UWX1E560MCL1GB
	56	6.3×5.4	0.16	14	65	UWR1E560MCL1GB
	100	8×5.4	0.14	25	110	UWX1E101MCL1GB
35 (1V)	4.7	4×5.4	0.12	3	18	UWX1V4R7MCL1GB
	10	5×5.4	0.12	3.5	29	UWX1V100MCL1GB
	10	4×5.4	0.14	3.5	24	UWR1V100MCL1GB
	22	6.3×5.4	0.12	7.7	46	UWX1V220MCL1GB
	22	5×5.4	0.14	7.7	39	UWR1V220MCL1GB
	33	8×5.4	0.12	11.55	62	UWX1V330MCL1GB
	33	6.3×5.4	0.14	11.55	53	UWR1V330MCL1GB
	47	8×5.4	0.12	16.45	80	UWX1V470MCL1GB
50 (1H)	1	4×5.4	0.12	3	8.4	UWX1H010MCL1GB
	2.2	4×5.4	0.12	3	13	UWX1H2R2MCL1GB
	3.3	4×5.4	0.12	3	17	UWX1H3R3MCL1GB
	4.7	5×5.4	0.12	3	20	UWX1H4R7MCL1GB
	4.7	4×5.4	0.14	3	18	UWR1H4R7MCL1GB
	10	6.3×5.4	0.12	5	33	UWX1H100MCL1GB
	10	5×5.4	0.14	5	30	UWR1H100MCL1GB
	22	8×5.4	0.12	11	52	UWX1H220MCL1GB
	22	6.3×5.4	0.14	11	43	UWR1H220MCL1GB
	33	8×5.4	0.12	16.5	71	UWX1H330MCL1GB

- Taping specifications are given in page 20.
- Recommended land size, soldering by reflow are given in page 16, 17.
- Please select UUR(p.171), UUG(p.181) if high C/V products are required.
- Please refer to page 3 for the minimum order quantity.

X-ON Electronics

Largest Supplier of Electrical and Electronic Components

Click to view similar products for [Nichicon](#) manufacturer:

Other Similar products are found below :

[PCR1C681MCL1GS](#) [LAR2E821MELC30](#) [LGJ2G121MELB20](#) [LKS1V103MESB](#) [LKS1V332MESA](#) [LLS1E682MELZ](#) [LNC2G182MSEF](#)
[LNC2G392MSEG](#) [LNC2G472MSEH](#) [LNC2G682MSEG](#) [LNC2G682MSEH](#) [LNC2V272MSEG](#) [LNC2V332MSEG](#) [LNC2W682MSEH](#)
[LNK2G122MSEF](#) [LNK2G182MSEF](#) [LNK2V182MSEF](#) [LNK2V222MSEF](#) [LNR1V334MSE](#) [LNT1C105MSE](#) [LNT1E154MSE](#)
[LNT1E474MSE](#) [LNT1J103MSE](#) [LNT2E103MSE](#) [LNT2E222MSE](#) [LNT2G392MSEH](#) [LNT2H222MSEG](#) [LNT2H471MSEF](#)
[LNU2G562MSEH](#) [LNUN7102MSEF](#) [LNX2H122MSEG](#) [LNX2H182MSEG](#) [LNX2V273MSEK](#) [LNX2W222MSEH](#) [LNX2W272MSEH](#)
[LNY2G222MSEF](#) [LNY2V682MSEG](#) [LNY2W182MSEG](#) [LNY2W392MSEH](#) [LQR2G562MSEH](#) [LQR2W472MSEG](#) [POLYHC-KIT](#)
[TVX1C220MAD](#) [UCA2W330MHD6](#) [UFW1H332MHD](#) [UHE1E102MHD6](#) [UHE1V102MHD1TO](#) [UHV1V102MHD](#) [UHW1E102MPD](#)
[UKA1V332MHD](#)