

RoHS compliant

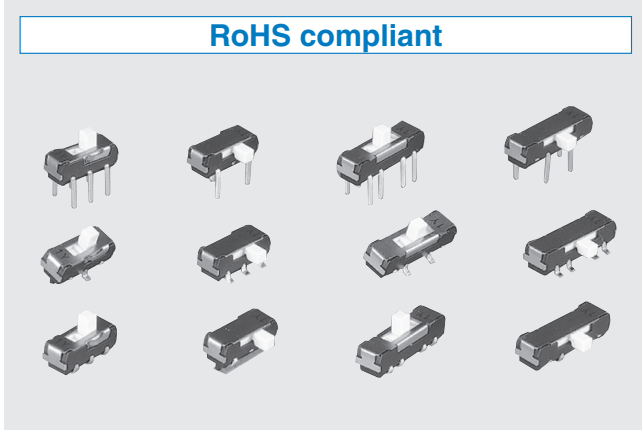

FEATURES

- Wide variety (circuit composition, operating direction, terminal shape: J-hook, Gull wing, Through hole pins)
- Standardization of the silver contacts as well as gold contacts
- Stroke is 2mm
- Using heat-resistant resin to support reflow soldering mounting
- Adopted Twin-contacts mechanism

INTERNAL STRUCTURE

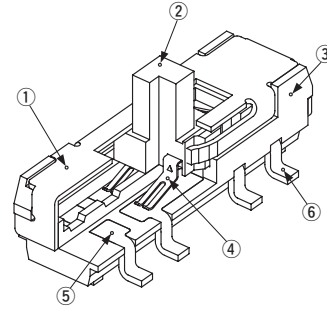

Part name	Material	Flammability
① Cover	Stainless steel (SUS 304)	—
② Slider	Polyamido	UL94V-0
③ Housing	Polyphenylenesulphide	UL94V-0
④ Moving contact	Copper alloy, gold or silver plate	—
⑤ Fixed contact	Copper alloy, gold or silver plate	—
⑥ Terminal pin	Copper alloy, gold or silver plate	—

PART NUMBER DESIGNATION

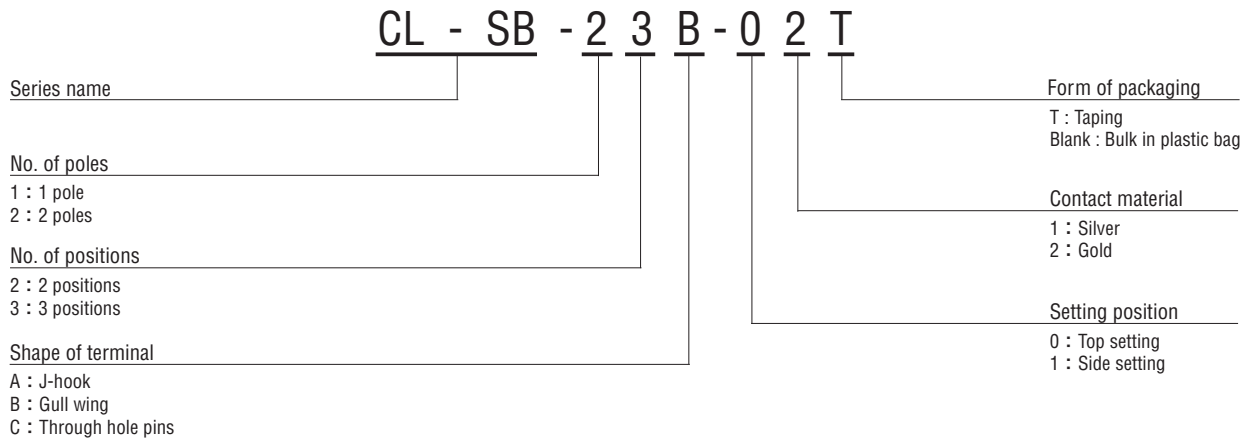

※ Please refer to the LIST OF PART NUMBERS when placing orders.

LIST OF PART NUMBERS

Setting position	No. of poles	No. of positions	Contact material		Shape of terminal	Form of packaging	Pieces in package
			Silver	Gold			
Top setting	1	2	CL-SB-12A-01T	CL-SB-12A-02T	A(J-hook)	Taping	500pcs. / reel
			CL-SB-12A-01	CL-SB-12A-02		Plastic bag	50pcs. / pack
			CL-SB-12B-01T	CL-SB-12B-02T	B(Gull wing)	Taping	500pcs. / reel
			CL-SB-12B-01	CL-SB-12B-02		Plastic bag	50pcs. / pack
		CL-SB-12C-01	CL-SB-12C-02	C(Through hole pins)	Plastic bag	50pcs. / pack	
		CL-SB-13A-01T	CL-SB-13A-02T	A(J-hook)	Taping	500pcs. / reel	
		CL-SB-13A-01	CL-SB-13A-02		Plastic bag	50pcs. / pack	
		CL-SB-13B-01T	CL-SB-13B-02T	B(Gull wing)	Taping	500pcs. / reel	
		CL-SB-13B-01	CL-SB-13B-02		Plastic bag	50pcs. / pack	
		CL-SB-13C-01	CL-SB-13C-02	C(Through hole pins)	Plastic bag	50pcs. / pack	
	2	2	CL-SB-22A-01T	CL-SB-22A-02T	A(J-hook)	Taping	500pcs. / reel
			CL-SB-22A-01	CL-SB-22A-02		Plastic bag	50pcs. / pack
			CL-SB-22B-01T	CL-SB-22B-02T	B(Gull wing)	Taping	500pcs. / reel
			CL-SB-22B-01	CL-SB-22B-02		Plastic bag	50pcs. / pack
		CL-SB-22C-01	CL-SB-22C-02	C(Through hole pins)	Plastic bag	50pcs. / pack	
		3	CL-SB-23A-01T	CL-SB-23A-02T	A(J-hook)	Taping	500pcs. / reel
			CL-SB-23A-01	CL-SB-23A-02		Plastic bag	50pcs. / pack
			CL-SB-23B-01T	CL-SB-23B-02T	B(Gull wing)	Taping	500pcs. / reel
			CL-SB-23B-01	CL-SB-23B-02		Plastic bag	50pcs. / pack
			CL-SB-23C-01	CL-SB-23C-02	C(Through hole pins)	Plastic bag	50pcs. / pack
Side setting	1		2	CL-SB-12A-11T	CL-SB-12A-12T	A(J-hook)	Taping
		CL-SB-12A-11		CL-SB-12A-12	Plastic bag		50pcs. / pack
		CL-SB-12B-11T		CL-SB-12B-12T	B(Gull wing)	Taping	500pcs. / reel
		CL-SB-12B-11		CL-SB-12B-12		Plastic bag	50pcs. / pack
		CL-SB-12C-11	CL-SB-12C-12	C(Through hole pins)	Plastic bag	50pcs. / pack	
		CL-SB-13A-11T	CL-SB-13A-12T	A(J-hook)	Taping	500pcs. / reel	
		CL-SB-13A-11	CL-SB-13A-12		Plastic bag	50pcs. / pack	
		CL-SB-13B-11T	CL-SB-13B-12T	B(Gull wing)	Taping	500pcs. / reel	
		CL-SB-13B-11	CL-SB-13B-12		Plastic bag	50pcs. / pack	
		CL-SB-13C-11	CL-SB-13C-12	C(Through hole pins)	Plastic bag	50pcs. / pack	
	2	2	CL-SB-22A-11T	CL-SB-22A-12T	A(J-hook)	Taping	500pcs. / reel
			CL-SB-22A-11	CL-SB-22A-12		Plastic bag	50pcs. / pack
			CL-SB-22B-11T	CL-SB-22B-12T	B(Gull wing)	Taping	500pcs. / reel
			CL-SB-22B-11	CL-SB-22B-12		Plastic bag	50pcs. / pack
		CL-SB-22C-11	CL-SB-22C-12	C(Through hole pins)	Plastic bag	50pcs. / pack	
		3	CL-SB-23A-11T	CL-SB-23A-12T	A(J-hook)	Taping	500pcs. / reel
			CL-SB-23A-11	CL-SB-23A-12		Plastic bag	50pcs. / pack
			CL-SB-23B-11T	CL-SB-23B-12T	B(Gull wing)	Taping	500pcs. / reel
			CL-SB-23B-11	CL-SB-23B-12		Plastic bag	50pcs. / pack
			CL-SB-23C-11	CL-SB-23C-12	C(Through hole pins)	Plastic bag	50pcs. / pack

※Verify the above part numbers when placing orders.

Taping version can be supplied only in reel unit.

CL-SB

SLIDE SWITCHES

STANDARD SPECIFICATIONS

Operating temperature range	- 40 ~ 85 °C	
Storage temperature range		
Sealing	Non- Washable	
Net weight	0.21 g (CL-SB-12*-0*) 0.22 g (CL-SB-22*-0*) 0.26 g (CL-SB-13*-0*) 0.28 g (CL-SB-23*-0*)	0.21 g (CL-SB-12*-1*) 0.23 g (CL-SB-22*-1*) 0.27 g (CL-SB-13*-1*) 0.29 g (CL-SB-23*-1*)

MECHANICAL CHARACTERISTICS

No. of positions	2, 3	
Stroke	2 mm	
Operation force	2 Contacts (CL-SB-*2*-***)	A ↔ B ※1 1.5 ± 1.0 N {0.153 ± 0.102kgf}
	3 Contacts (CL-SB-*3*-***)	A → B / C → B ※2 1.5 ± 1.0 N {0.153 ± 0.102kgf} B → A / B → C 2.5 ± 1.5 N {0.255 ± 0.153kgf}
Stop strength	20 N {2.04 kgf} 15 s	
Solderability	245 ± 3 °C, 2 ~ 3 s	
Soldering heat	Reflow : 255 °C (Peak temperature) (Please refer to the profile below)	
	Flow : 260 ± 3 °C, 5 ~ 6 s	
	Manual soldering : 350 ± 10 °C, 3 ~ 4 s	
Shear	5 N {0.51 kgf} 10 s	
Substrate bending	Width 90 mm, bend 3 mm, 5 s, 1 time	
Pull-off strength	5 N {0.51 kgf} 10s	

{ } : Reference only



ELECTRICAL CHARACTERISTICS

Contact rating	DC50 V 200 mA DC12 V 200 mA DC20 mV 1 μ A (Gold contacts) DC5 V 10 mA (Silver contacts)	
Contact timing	Non-shorting	
Contact resistance	70m Ω maximum (Gold contacts) 50m Ω maximum (Silver contacts)	1.5 mA 1 kHz 20 mV maximum
Insulation resistance	100 M Ω minimum (DC500 V)	
Dielectric strength	AC500 V, 60 s	

ENVIRONMENTAL CHARACTERISTICS

Vibration	(Amplitude) 1.5 mmor (Acceleration) 98 m/s ² , 10-500-10 Hz, 3 directions for 2 h each
Shock	490 m/s ² , 11 ms 6 directions for 3 times each
Load life	10000 cycles, DC12 ± 0.5V, 200 ± 10mA
Humidity	40 °C, Relative humidity 90 ~ 95 %, 240 h, No load
High temperature exposure	85 °C, 96 h, No load
Low temperature exposure	- 40 °C, 96 h, No load
Thermal shock	- 40 (0.5 h) ~ 85 °C (0.5 h), 5 cycles

<Reflow profile for soldering heat evaluation>

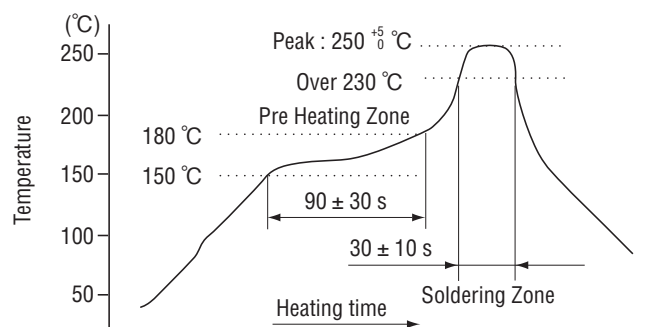

Reflow : two times maximum

OUTLINE DIMESIONS

Unless otherwise specified, tolerance: ± 0.3 (Unit: mm)

- CL-SB-12A-01
- CL-SB-12A-02

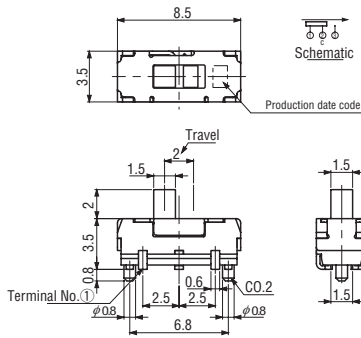

- CL-SB-12B-01
- CL-SB-12B-02

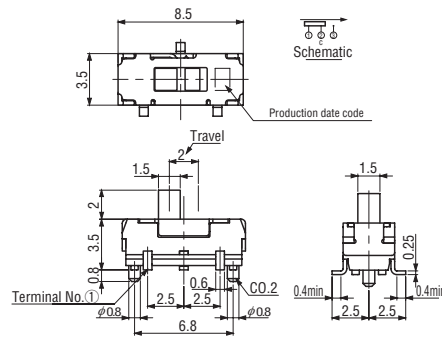

- CL-SB-12C-01
- CL-SB-12C-02

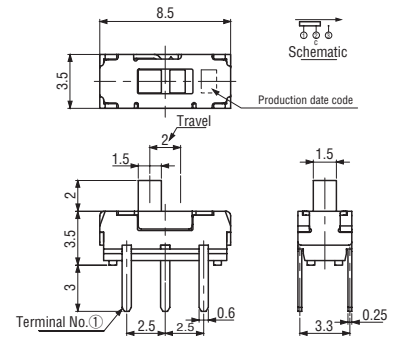

- CL-SB-12A-11
- CL-SB-12A-12

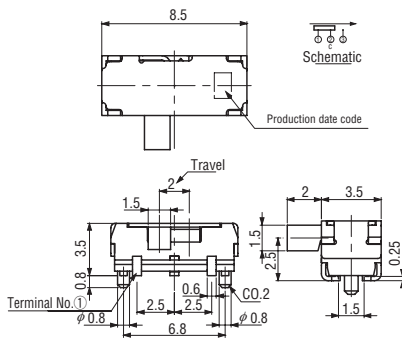

- CL-SB-12B-11
- CL-SB-12B-12

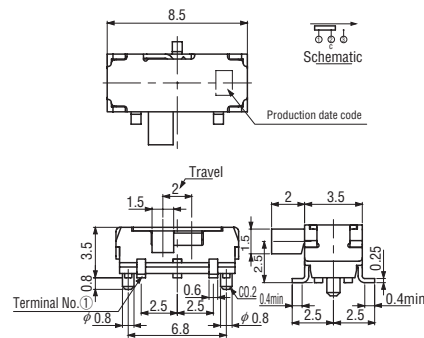

- CL-SB-12C-11
- CL-SB-12C-12

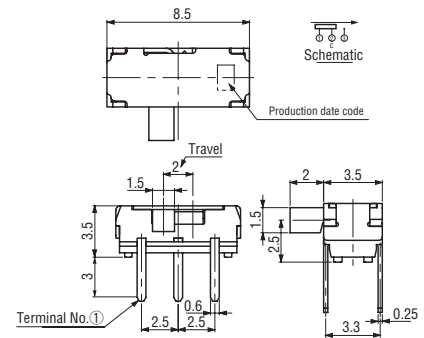

- CL-SB-22A-01
- CL-SB-22A-02

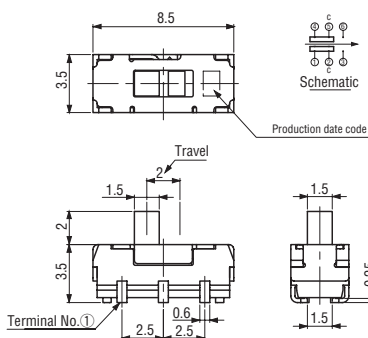

- CL-SB-22B-01
- CL-SB-22B-02

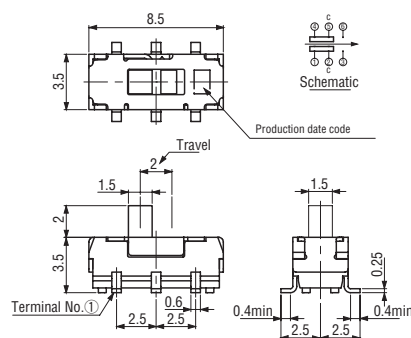

- CL-SB-22C-01
- CL-SB-22C-02

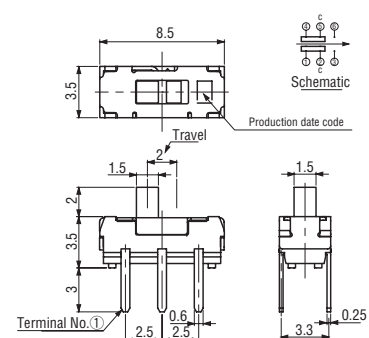

CL-SB SLIDE SWITCHES

OUTLINE DIMESIONS

Unless otherwise specified, tolerance: ± 0.3 (Unit: mm)

- CL-SB-22A-11
- CL-SB-22A-12

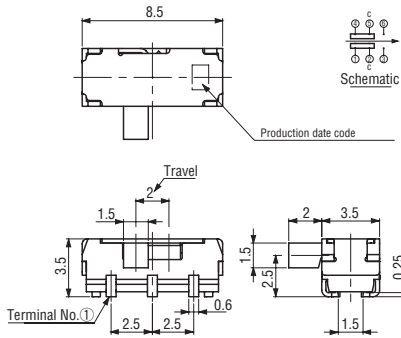

- CL-SB-22B-11
- CL-SB-22B-12

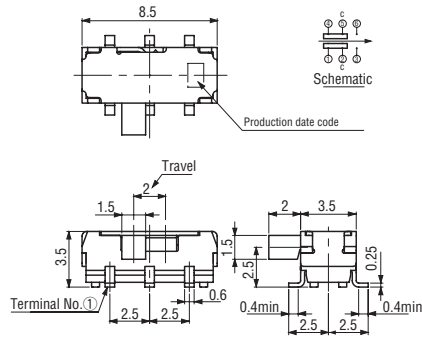

- CL-SB-22C-11
- CL-SB-22C-12

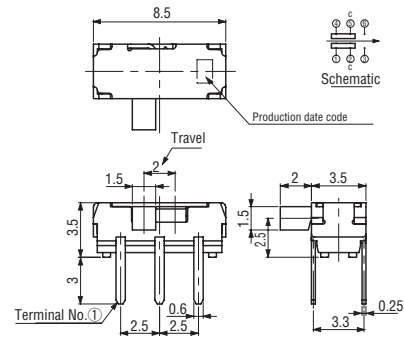

- CL-SB-13A-01
- CL-SB-13A-02

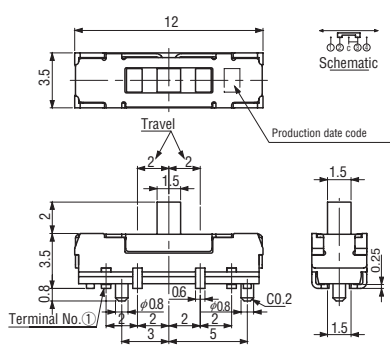

- CL-SB-13B-01
- CL-SB-13B-02

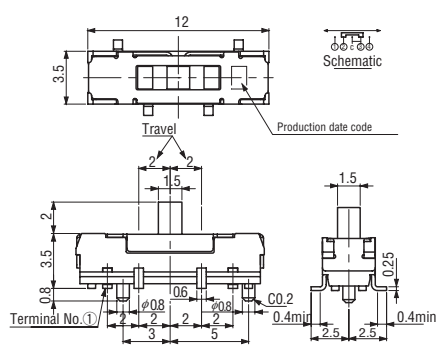

- CL-SB-13C-01
- CL-SB-13C-02

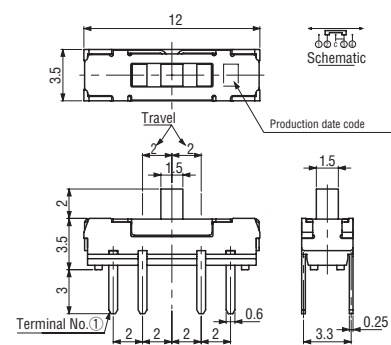

- CL-SB-13A-11
- CL-SB-13A-12

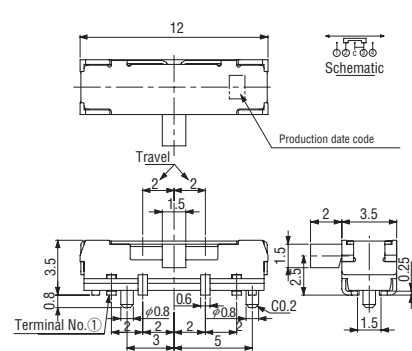

- CL-SB-13B-11
- CL-SB-13B-12

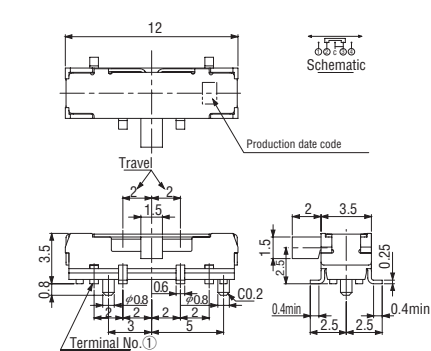

- CL-SB-13C-11
- CL-SB-13C-12

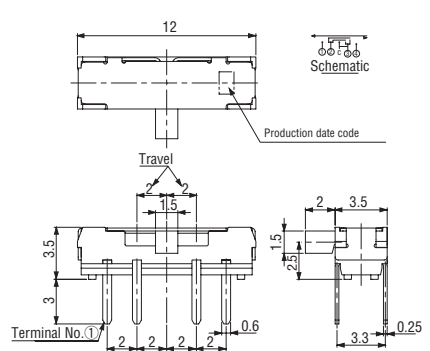

- CL-SB-23A-01
- CL-SB-23A-02

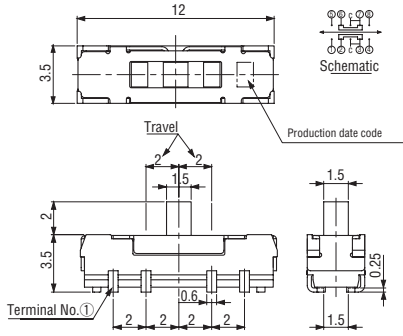

- CL-SB-23B-01
- CL-SB-23B-02

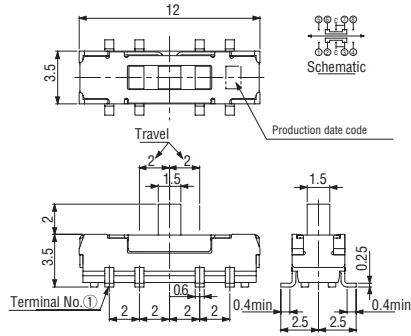

- CL-SB-23C-01
- CL-SB-23C-02

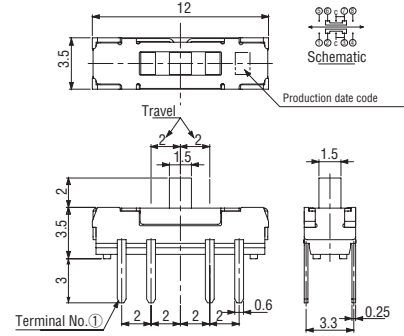

- CL-SB-23A-11
- CL-SB-23A-12

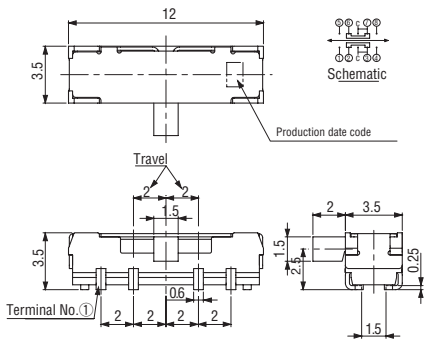

- CL-SB-23B-11
- CL-SB-23B-12

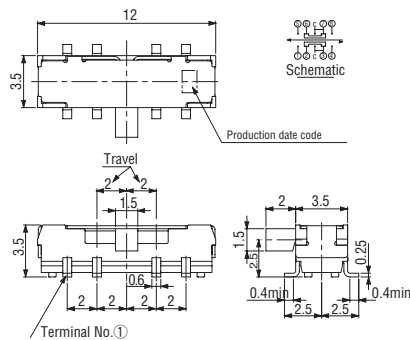

- CL-SB-23C-11
- CL-SB-23C-12

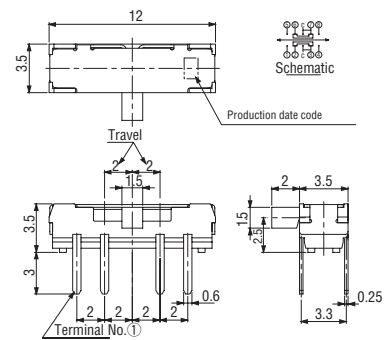

PACKAGING SPECIFICATIONS

<Bulk pack specifications>

- The smallest unit of bulk pack in plastic bag is 10 pcs. per pack. Orders will be accepted for unit of minimum 10 pcs., i.e., 10, 20, 30 pcs., etc.
- Boxing of bulk in a plastic bag is performed with 50 pcs. per box.

<Taping specifications>

- Taping version is packaged in 500 pcs. per reel. Orders will be accepted for units of 500 pcs., i.e., 500, 1000, 1500, pcs., etc.
- Taping version is boxed with one reel (500 pcs.).

Maximum number of consecutive missing pieces=2
Leader length and reel dimension are shown in the diagrams below:

● Embossed tape dimensions

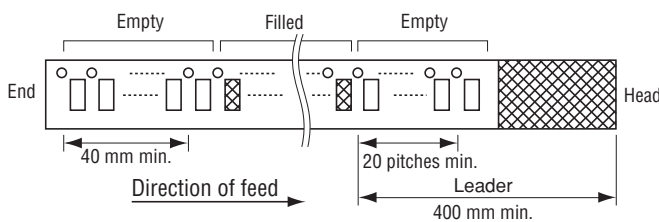

● Reel dimensions (Unit: mm)

(Conforms to JIS C 0806-3)
(In accordance with EIAJ ET-7200A)

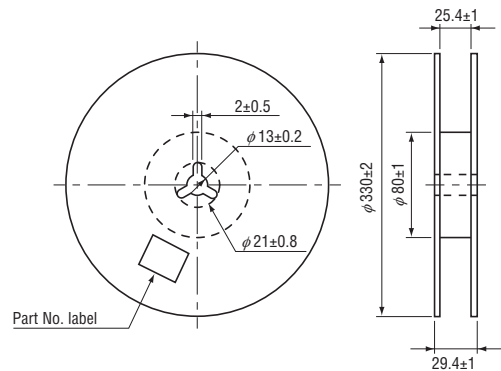

<Tape dimensions>

Unless otherwise specified, tolerance: ± 0.3 (Unit: mm)

● CL-SB-12A/12B-0 □ T

● CL-SB-22A/22B-0 □ T

(Conforms to JIS C 0806)

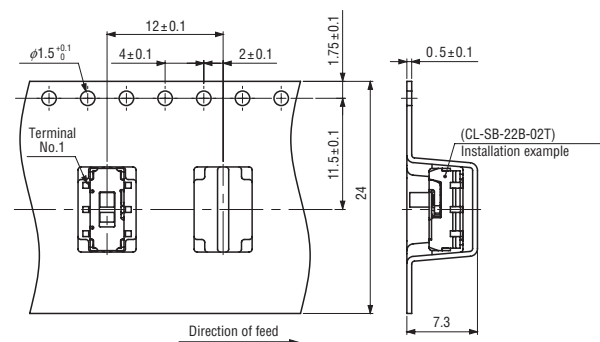
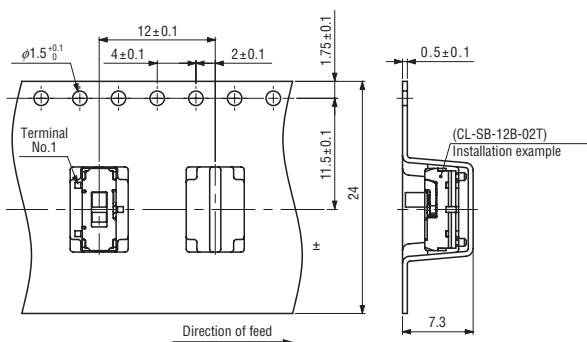

CL-SB SLIDE SWITCHES

<Tape dimensions>

Unless otherwise specified, tolerance: ± 0.3 (Unit: mm)

● CL-SB-13A/13B-0 □ T

● CL-SB-23A/23B-0 □ T

(Conforms to JIS C 0806)

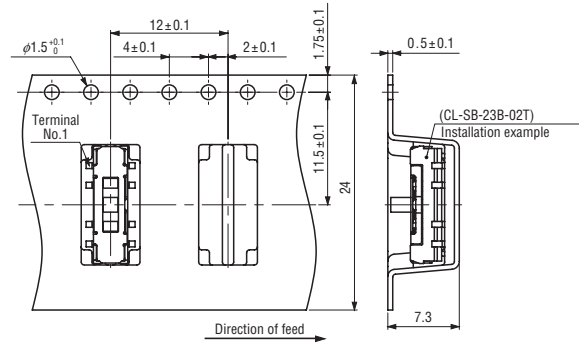
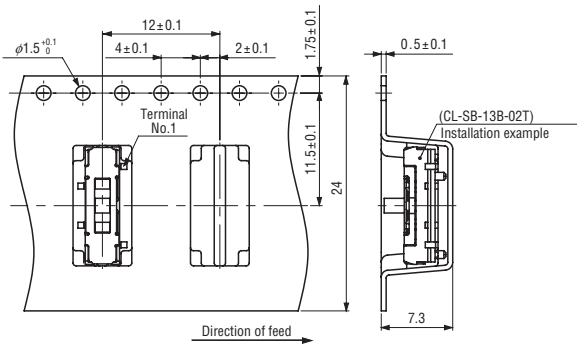

● CL-SB-12A/12B-1 □ T

● CL-SB-22A/22B-1 □ T

(Conforms to JIS C 0806)

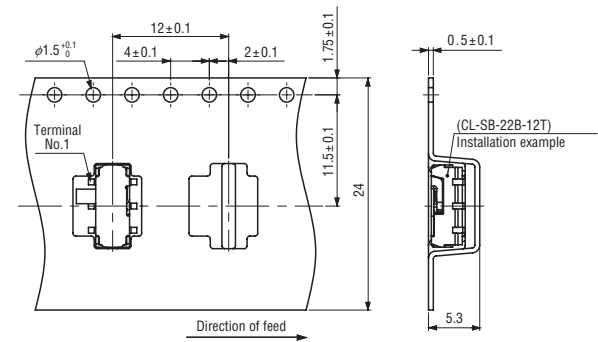
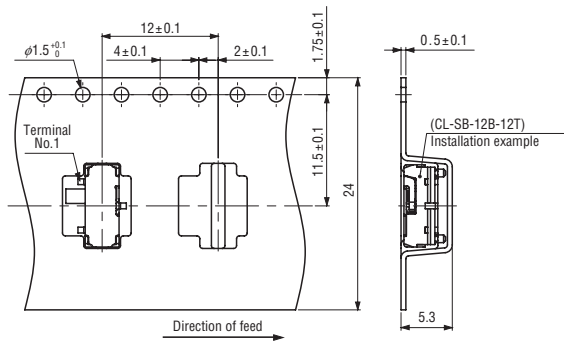

● CL-SB-13A/13B-1 □ T

● CL-SB-23A/23B-1 □ T

(Conforms to JIS C 0806)

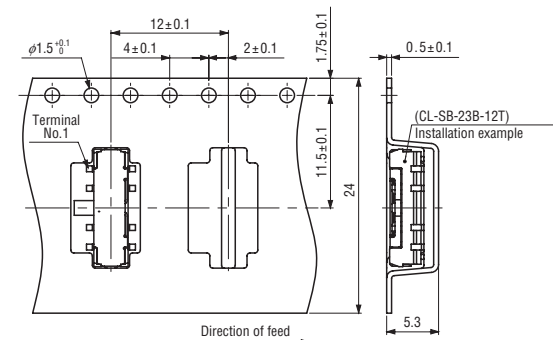
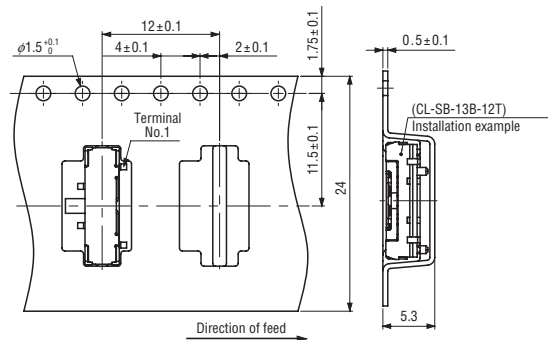

X-ON Electronics

Largest Supplier of Electrical and Electronic Components

Click to view similar products for [Slide Switches](#) category:

Click to view products by [Nidec Copal](#) manufacturer:

Other Similar products are found below :

[6-1437581-1](#) [M43R](#) [MHS123K15D](#) [MHSS1104A](#) [MMD](#) [GH49S010001](#) [GH49WW00001](#) [1437576-8](#) [EPS1PC1](#) [1825074-1](#) [1825160-3](#)
[1825167-2](#) [25139NLDB](#) [25436NLDB](#) [25449NAH](#) [25536NA](#) [L101011ML04B](#) [SLB1240R45](#) [SLSA12004](#) [1825078-1](#) [1825080-4](#) [1825081-1](#)
[1825269-1](#) [1825270-2](#) [STS141RA04](#) [T2215BEN506](#) [GF-124-0204](#) [GH46P000001](#) [GH46W000001](#) [GH49P010001](#) [25339NA](#) [25436NLDH](#)
[CST91246FK](#) [TG36P000000](#) [TG36P000050](#) [47227LFE](#) [49331L](#) [MHSS1105A](#) [50208L](#) [HW4S-5LF22N3](#) [L202091MS02Q](#) [4-1437581-7](#)
[X2225CR-437W](#) [48BFSP3M2QT](#) [49329L](#) [1101M1S3ZB8E2](#) [1-1437581-1](#) [EG1218REDACTUATOR](#) [TG39W000000](#) [1825075-1](#)