

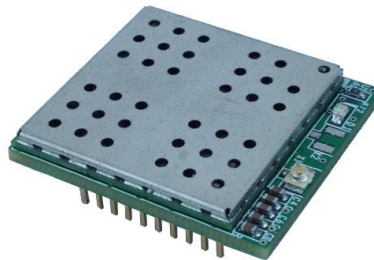

# Skywire™ 1xRTT Embedded Cellular Modem Datasheet

NimbeLink Corp

Updated: September 2014



<b>1. INTRODUCTION .....</b>	<b>3</b>
1.1 ORDERABLE PART NUMBERS .....	3
1.2 ADDITIONAL RESOURCES.....	3
1.3 PRODUCT OVERVIEW .....	3
1.4 BLOCK DIAGRAM.....	4
<b>2. TECHNICAL SPECIFICATIONS .....</b>	<b>5</b>
2.1 ELECTRICAL SPECIFICATIONS .....	5
2.2 MECHANICAL SPECIFICATIONS.....	6
2.3 TEMPERATURE SPECIFICATIONS.....	8
<b>3. IMPORTANT DESIGN CONSIDERATIONS.....</b>	<b>8</b>
3.1 ON_OFF SIGNAL.....	8
3.2 POWER SUPPLY REQUIREMENTS.....	8
<b>4. MOUNTING GUIDELINES.....</b>	<b>9</b>
4.1 BOARD TO BOARD CONNECTORS APPROACH .....	9
4.2 SOLDER TO BOARD CONNECTION APPROACH.....	10
<b>5. ANTENNA CONSIDERATIONS .....</b>	<b>11</b>
5.1 ANTENNA SPECIFICATIONS .....	11
5.2 RECOMMENDED ANTENNAS .....	11
<b>6. CERTIFICATIONS.....</b>	<b>12</b>
6.1 CARRIER SPECIFIC.....	12
6.2 GEOGRAPHY SPECIFIC.....	12
<b>7. END PRODUCT LABELING REQUIREMENTS.....</b>	<b>12</b>

# 1. Introduction

## 1.1 Orderable Part Numbers

Orderable Device	Operating Temperature	Carrier	Network Type
NL-SW-1xRTT-V	-40 to +85°C	Verizon	CDMA 1xRTT
NL-SW-1xRTT-A	-40 to +85°C	AERIS	CDMA 1xRTT

## 1.2 Additional Resources

The following documents or documentation resources are referenced within this document.

- Telit's [CE910 Hardware User Guide](#)

## 1.3 Product Overview

Add robust cellular connectivity to your M2M devices without the cost, delay, and hassle of federal and carrier certifications. Extensive experience in designing and building embedded product solutions makes the NimbeLink Skywire™ embedded cellular modem the smallest on the market. It complies with the popular XBEE interface standard and supports 1xRTT communication, minimizing costs of hardware and network access. The module is designed for volume production and is intended for OEMs to embed into end equipment designs.

# 1.4 Block Diagram

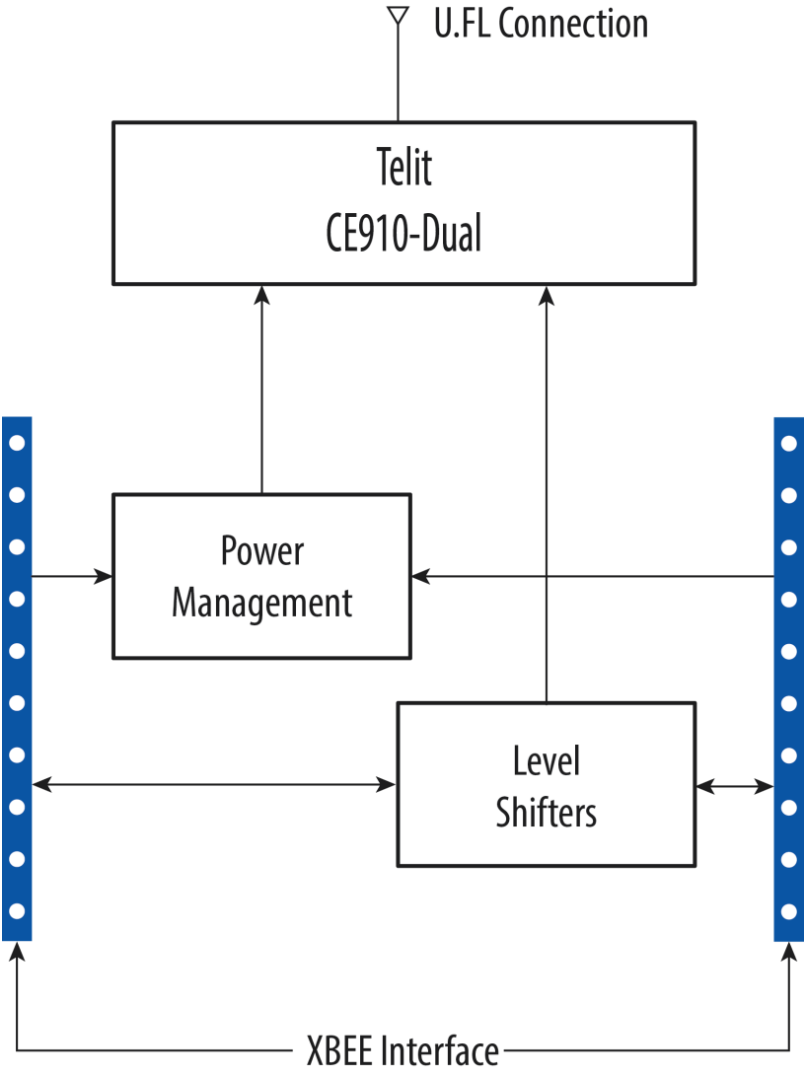

## 2. Technical Specifications

### 2.1 Electrical Specifications

#### 2.1.1 Absolute Maximum Ratings

Parameter	Signal	Rating
Main Power Supply	VCC	4.3V
I/O Voltage Reference	VREF	5.5V

#### 2.1.2 Recommended Ratings & Module Pin out

Pin	Name	Direction	Description	Min	Typical	Max	If not used
1	VCC	Input	Main Power supply	3.5V	3.9V	4.3V	Must be implemented
2	DOUT	Output	UART data out, I/O level tied to VREF	VOL: GND to 0.55V		VOH: VREF x 0.67 to VREF	Must be implemented
3	DIN	Input	UART data in, I/O level tied to VREF	VIL: GND to 0.15V		VIH: VREF-0.4V to VREF	Must be implemented
4	GND	Input	Ground Pin		0		Must be implemented
5	RESET_nIN	Input	Controls HW_SHUTDOWN input on Telit CE910-DUAL, tie low for 800mS to activate. Internally pulled up to VCC with 57k resistor. Drive with open collector output. Assert only in an emergency as the module will not gracefully exit the cellular network when asserted.		VREF		No connection
6	VUSB	Input	Supply for USB interface	4.4V	5V	5V	No connection
7	USB_D+	I/O	USB differential Data + signal				No connection
8	USB_D-	I/O	USB differential Data - signal				No connection
9	DTR	Input	Modem Data Terminal Ready input	VIL: GND to 0.15V		VIH: VREF-0.4V to VREF	Tie to GND
10	GND	Input	Ground Pin		0		Must be implemented
11	GND	Input	Ground Pin		0		Must be implemented
12	CTS	Output	Modem Clear to Send hardware flow control output	VOL: GND to 0.55V		VOH: VREF x 0.67 to VREF	No connection

13	ON/nSLEEP	Output	Signal drives the onboard LED indicating network status. OFF = Device OFF, Fast blink = Searching for Network & Not Registered, Slow Blink = Registered with full service, Permanently on = call is active. See Telit CE910-DUAL manual for additional information.	0		1.8V	No connection
14	VREF	Input	Voltage reference for offboard I/O signals. This signal drives the input voltage side of an onboard buffer which converts all external I/O voltage from VREF range to 1.8V range to drive the onboard Telit CE910-DUAL modem module.	1.65V	1.8V or 3.3V	5.5V	Must be implemented
15	GND	Input	Ground Pin		0		Must be implemented
16	RTS	Input	Modem Request to Send hardware flow control input	VIL: GND to 0.15V		VIH: VREF-0.4V to VREF	Tie to GND
17	DIO3	I/O	Programmable GPIO_03 on Telit CE910-DUAL module	0		1.8V	No connection
18	DIO2	I/O	Programmable GPIO_02 on Telit CE910-DUAL module	0		1.8V	No connection
19	ADC1	Input	ADC_IN1 input on Telit CE910-DUAL module (12bit resolution, <1mV, input resistance 1Mohm)	0		1.2V	No connection
20	ON_OFF	Input	Modem On/Off signal. Assert low for at least 1 second and then release to activate start sequence. Drive with open collector output. Internally pulled up to internal I/O rail with 200k pull up. Do not use any external pull ups. <b>Note:</b> If you want modem to turn on automatically when power is applied, permanently tie this signal to GND.	0		1.8V	Must be implemented.

## 2.2 Mechanical Specifications

### 2.2.1 Mechanical Characteristics

Parameter	Typical	Unit
Dimensions (excluding pin height, for solder to board applications)	29.0 x 33.60 x 6.63	mm
Dimensions (including pin height, for board to board connector applications)	29.0 x 33.60 x 10.73	mm
Weight	x	Grams
Connector Insertion/Removal	hundreds	Cycles

### 2.2.2 Mating Connectors

Connector Designator	Manufacture	Populated on Module	Recommended Mate	Mate Manufacture
J1, J2	3M	951110-2530-AR-PR	950510-6102-AR	3M
			Acceptable alternate: NPPN101BFCN-RC	Sullins Connector Solutions
X1	Hirose	U.FL-R-SMT(10)	CAB.011	Taoglas

## 2.3 Temperature Specifications

Parameter	Min	Typical	Max	Unit
Operating Temperature	-40	25	+85	°C
Storage Temperature	-40	25	+85	°C

## 3. Important Design Considerations

### 3.1 ON\_OFF Signal

To conserve power, the Telit CE910-DUAL does not automatically start up when power is applied. The baseboard design must supply a means to assert the ON\_OFF signal for the specified time (1 second < hold time < 2 seconds) to start-up the module. To make module automatically start when power is applied, tie ON/OFF signal to GND permanently. See Telit Hardware User Guide for additional details regarding the ON\_OFF signal.

### 3.2 Power Supply Requirements

The module will regularly consume high amounts of current on the Main Power Supply (VCC), up to 750mA during active transmits and receives. The baseboard power supply should be designed to support peak currents up to 1 Amp. A 100uF capacitor should be placed near the VCC pin on the module to ensure ample energy is available, with a low inductance path to the VCC pin. For example power supply designs, there are multiple references available. See the NimbeLink Skywire™ Development Kit schematic for a switching regulator example, or reference the Telit Hardware User Guide which has an example of both Linear and Switching regulator designs.



# 4. Mounting Guidelines

The Skywire™ embedded cellular modem supports multiple connection methods, the two primary methods are board to board connectors and soldering directly to the baseboard.

## 4.1 Board to Board connectors approach

The XBEE form factor calls for two, 10 pin, 2mm pitch female receptacles.

There are many connector manufactures that can be used; below is one readily available product:

Manufacture: 3M

Alternate: Sullins Connector Solutions

Part Number: 950510-6102-AR

Alternate P/N: NPPN101BFCN-RC

Typical part drawing and footprint information:

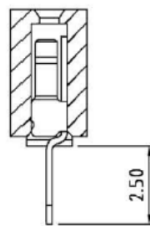
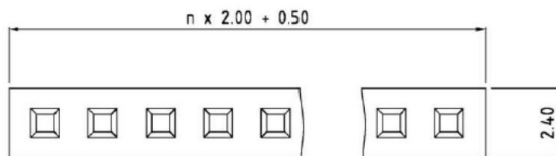
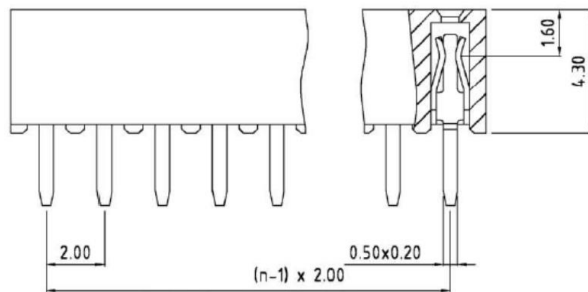

PCB Layout

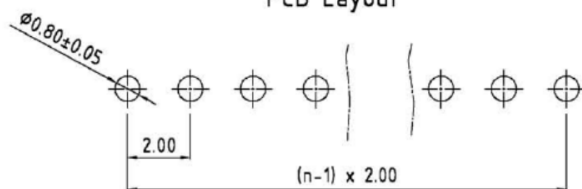

## 4.2 Solder to Board connection approach

The module can be soldered directly to a PCB. The PCB should be designed with two rows of ten, 0.8mm plated thru holes spaced 2mm apart. The two rows should be 22mm apart. See drawing for recommended footprint. Measurements are in millimeters.

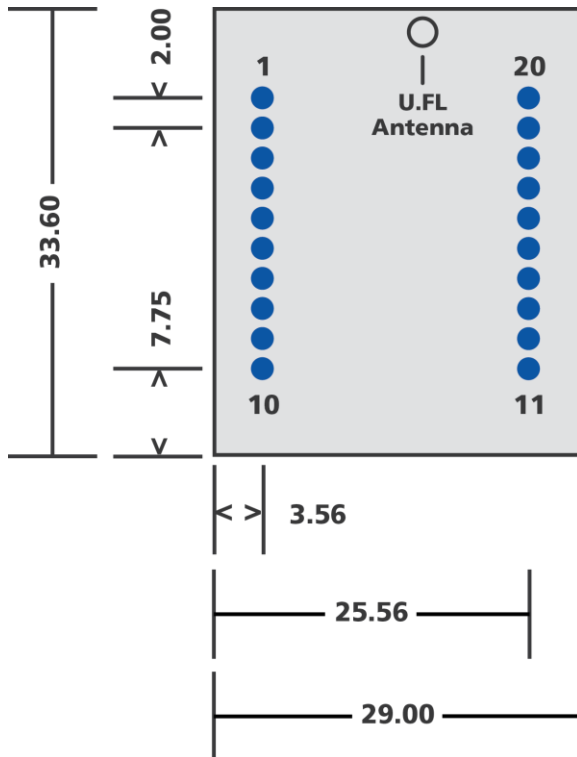

# 5. Antenna Considerations

## 5.1 Antenna Specifications

Parameter	Signal
Type	800/1900Mhz Primary
Bandwidth in CDMA BC0	70Mhz
Bandwidth in CDMA BC1	140Mhz
Max Gain in CDMA BC0	5.12dBi
Max Gain in CDMA BC1	6.12dBi
Impedence	50 Ohm
Input Power (Average Power)	>24.5dBm
VSWR recommended	<2:1

## 5.2 Recommended Antennas

Manufacturer	Signal
MobileMark	PSKN3-900/1900S
Taoglas	TG.30.8113

## **6. Certifications**

### **6.1 Carrier Specific**

Verizon OD Certified

### **6.2 Geography Specific**

Federal Communications Commission (FCC) part 22, 24

Complies with FCC Part 15 Class B Radiated and Conducted Emissions

## **7. End Product Labeling Requirements**

Device Uses Approved Radio: NL-SW-1xRTT

Contains FCC ID: RI7CE910-DUAL and IC ID: 5131A-CE910DUAL

This device complies with Part 15 of the FCC Rules. Operation is subject to the following two conditions: (1) This device may not cause harmful interferences, and (2) this device must accept any interference received, including interference that may cause undesired operation.

## **X-ON Electronics**

Largest Supplier of Electrical and Electronic Components

*Click to view similar products for [nimbelink](#) manufacturer:*

Other Similar products are found below :

[NL-SW-EVDO-V](#) [NL-SW-HSPAPG](#) [NL-SW-GPRS](#) [NL-AB-BBBC](#)