

Issue date: *Nov. 10. 09*

Specification

No. G090510A0132Z1 - 1 to 9

Electrolytic Capacitors

# Specifications

Customer Part No. : \_\_\_\_\_

Customer Specification No. : \_\_\_\_\_ Nippon Chemi-con Part No. : ECST160ELL332MJ35S

## Nippon Chemi-Con Corporation

Chemi-Con Iwate Corporation

Design Group Manager

*T. Hino*

---

Receipt Stamp

1. Scope

This specification defines the requirements for aluminum electrolytic capacitors which comply with the first symbol W of JIS C 5141- 1991.

2. Part Numbering System

Example;

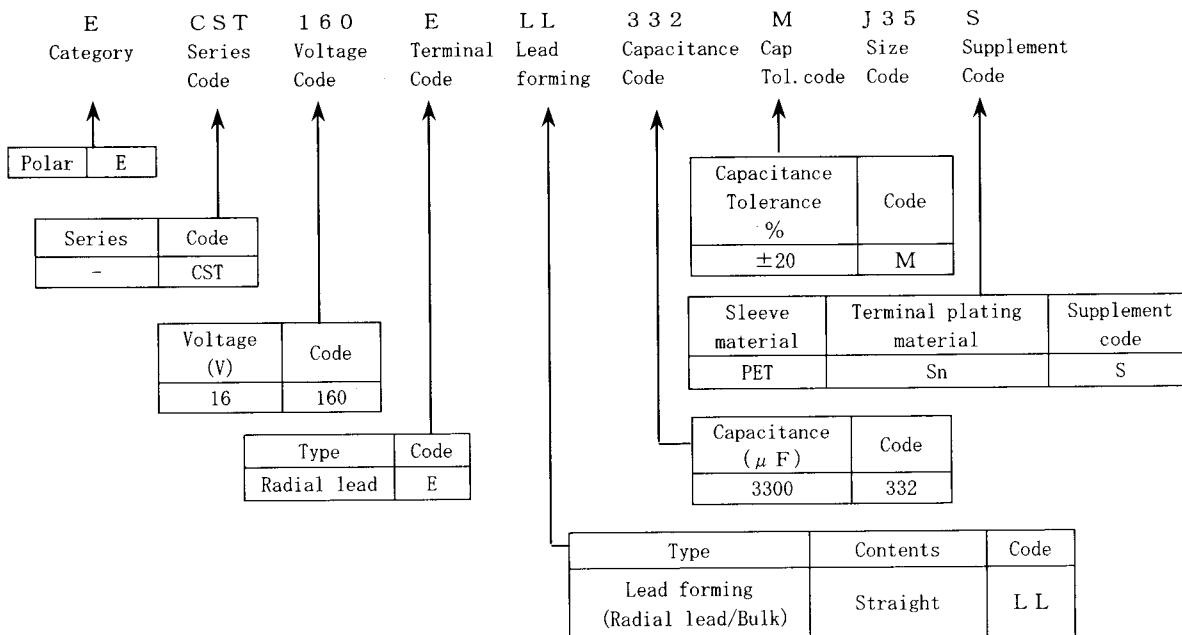

Size code and case size table

Size code	Case size φ D × L mm
J35	10 × 35

3. Rating

No.	Item	Specification	
1	Category temperature range	-40 to +105°C	
2	Rated voltage	16 Vdc	
3	Surge voltage	20 Vdc	
4	Nominal capacitance	3300 μF	+20°C, 120Hz
5	Capacitance tolerance	-20 to +20%	+20°C, 120Hz
6	Dissipation factor	0.2 max.	+20°C, 120Hz
7	Leakage current	528 μA max.	+20°C, after 2 minutes
8	Rated ripple current	2460 mArms	+105°C, 100kHz
9	Impedance	0.023 Ω max.	+20°C, 100kHz

4. Performance

Unless otherwise specified, the capacitors shall be measured at +15 to +35°C, 45 to 75%RH and 86 to 106kPa. However, if any doubt arises on the judgment, the measurement conditions shall be +20±2°C, 60 to 70%RH and 86 to 106kPa. The test conditions shall comply with JIS C 5102-1994.

4.1 Leakage current (L.C.)

[Conditions] DC leakage current shall be measured with rated voltage, which is applied through a resistor of 1,000 ±10Ω connected in series with the capacitors, at the end of a specified period after the capacitors reached the rated voltage across the terminals.

[Criteria] Shall not exceed the values specified in the item 3.

4.2 Capacitance (Cap.)

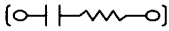
[Conditions] Measuring frequency : 120Hz±20%  
 Measuring voltage : 0.5Vrms max. +1.5 to 2.0V<sub>DC</sub>  
 Measuring circuit : Series equivalent circuit (  )

[Criteria] Shall be within the specified capacitance tolerance.

4.3 Dissipation factor (tan δ)

[Conditions] Measuring frequency : 120Hz±20%  
 Measuring voltage : 0.5Vrms max. +1.5 to 2.0V<sub>DC</sub>  
 Measuring circuit : Series equivalent circuit (  )

[Criteria] Shall not exceed the values specified in the item 3.

4.4 Temperature characteristics

[Conditions]

unit °C

Step	Temperature
1	+20±2
2	-10±3, -25±3, -40±3
3	+20±2
4	+105±2

Step 1: Measure capacitance and impedance (at 120Hz±10%).

Step 2: Measure impedance (at 100kHz±10%, 120Hz±10%).

Step 3: No measurement for the electrical characteristics.

Step 4: Measure capacitance, tan δ and leakage current.

[Criteria] Step 2: Impedance : Shall not exceed the values specified in the item 3.

Impedance ratio shall not exceed the values shown in Table-1 attached.

4.5 Terminal strength

(1) Pull strength

[Conditions] The capacitor body shall be held. A force shall be gradually applied to the lead wire in the direction of the axis of the lead wire up to the specified pull force, and retained for 10±1 seconds.

Nominal lead diameter mm	Pull force N
Over 0.5 to 0.8 incl.	10

[Criteria] The lead wire shall neither loosen nor break away.

(2) Lead bending strength

[Conditions] The capacitor shall be held so that the normal axis of the lead wire can be in a vertical position. A weight equivalent to the specified load shall be hung on the end of the lead wire. The capacitor body shall be inclined through 90° and returned to its normal position within 2 to 3 seconds. The consecutive bend shall then be in the opposite direction in the same manner

Nominal lead diameter mm	Bending load N
Over 0.5 to 0.8 incl.	5

[Criteria] The lead wire shall neither loosen nor break away.

4.6 Vibration

[Conditions] Vibration frequency range : 10 to 55Hz  
 Peak to peak amplitude : 1.5mm  
 Sweep rate : 10 to 55 to 10Hz in about 1 minute  
 Direction and period of motion : 2 hours in each of 3 mutually perpendicular directions (total of 6 hours)

Note: Capacitors shall be mounted on the pc board with their lead wires anchored at 4mm max. of their bodies, except for the capacitors with the case size φ16×30L, whose lead wire shall be anchored at 1mm max. of their bodies. The body of the capacitor with 12.5mm or larger in diameter or 25mm or longer in length, in addition, shall be anchored to the pc board with a fixture.

[Criteria] Capacitance (during test) : The reading shall be stable.  
 Appearance : No significant damage.  
 Capacitance change : Shall be within ±5% of the initial measured value.

#### 4.7 Solderability

[Conditions]	Type of solder	: Sn-3Ag-0.5Cu
	Flux	: Ethanol solution (25 wt.% rosin)
	Solder temperature	: $+245 \pm 3^{\circ}\text{C}$
	Depth of immersion	: Up to 1.5 to 2.0mm
	Speed of immersion	: 1.5mm/sec.
[Criteria]	Solder shall cover at least 3/4 of the lead surface immersed.	

#### 4.8 Soldering heat

[Conditions]	Type of solder	: Sn-3Ag-0.5Cu
	Flux	: Ethanol solution (25 wt.% rosin)
	Solder temperature/immersion time	: $+260 \pm 5^{\circ}\text{C}$ for $10 \pm 1$ seconds or $+380 \pm 10^{\circ}\text{C}$ for $3 \pm 0.5$ seconds.
	Depth of immersion	: Up to 1.5 to 2.0mm from the root of the lead wire covered with a thermal screen.
	Speed of immersion	: $25 \pm 2.5$ mm/sec.
[Criteria]	Appearance	: No significant damage.
	Leakage current	: Shall not exceed the initial specified value.
	Capacitance change	: Shall be within $\pm 10\%$ of the initial measured value.
	Tan $\delta$	: Shall not exceed the initial specified value.

#### 4.9 Operation of pressure relief vent

[Conditions]	Apply a reverse voltage with DC current 1 amp. (DC reverse voltage test)	
[Criteria]	When the pressure relief vent operated, the capacitor shall not flame although gas generation or expulsion of a part of the inside element is allowable.	
	If the vent does not operate with the voltage applied for 30 minutes, the test is considered to be passed.	

#### 4.10 Humidity exposure

[Conditions]	Test temperature	: $+40 \pm 2^{\circ}\text{C}$
	Relative humidity	: 90 to 95%RH
	Test time	: $240 \pm 8$ hours
[Criteria]	Appearance	: No significant damage
	Leakage current	: Shall not exceed the initial specified value.
	Capacitance change	: Shall be within $\pm 20\%$ of the initial measured value.
	Tan $\delta$	: Shall not exceed 120% of the initial specified value.

#### 4.11 Endurance

[Conditions]	After the capacitors are subjected to DC voltage with the rated ripple current applied for the specified periods of time at $+105 \pm 2^{\circ}\text{C}$ , the following specifications shall be satisfied when the capacitors are restored to $+20^{\circ}\text{C}$ . The sum of DC voltage and peak AC voltage must not exceed their full rate voltage.	
	Specified test time	: $4,000^{+72}_0$ hours
[Criteria]	Leakage current	: Shall not exceed the initial specified value.
	Capacitance change	: Shall be within $\pm 25\%$ of the initial measured value.
	Tan $\delta$	: Shall not exceed 200% of the initial specified value.

#### 4.12 Shelf life

[Conditions]	The capacitor shall be subjected to $+105 \pm 2^{\circ}\text{C}$ for $500^{+24}_0$ hours without voltage applied, and the capacitor is then restored to $+20^{\circ}\text{C}$ for the measurements. Before the measurements, the capacitor shall be preconditioned by applying voltage according to item 4.4 of JIS C 5102.	
[Criteria]	Leakage current	: Shall not exceed the initial specified value.
	Capacitance change	: Shall be within $\pm 25\%$ of the initial measured value.
	Tan $\delta$	: Shall not exceed 200% of the initial specified value.

5. Others

5.1 Table

Table-1

Rated voltage V <sub>DC</sub>	16
Z-25°C/Z+20°C	2
Z-40°C/Z+20°C	3

5.2 Multipliers for ripple current

Frequency multipliers

Frequency Capacitance	120Hz	1kHz	10kHz	100kHz
3300 $\mu$ F	0.75	0.90	0.95	1.00

When frequency is different from the specified condition shown in the item 3, do not exceed the value obtained by multiplying the permissible maximum ripple current by the multiplier above.

5.3 Export Trade Control Ordinance (When our product our is exported from Japan)

1. Export Trade Control Ordinance (Section 1 through 15 of Appendix Table 1)

Export regulation of the capacitors for pulse use (750V or higher) and the capacitors for high voltage (5,000V or higher) is carried out in (item 41-4) in Section 2 of Appendix Table 1 (Section 49 in Chapter 1 of METI' s Ordinance) and (item 7) in Section 7 of Appendix Table 1 (Section 6 in Chapter 6 of METI' s Ordinance). Therefore, the aluminum electrolytic capacitors are not applicable to Export Trade Control Ordinance. However, the aluminum electrolytic capacitors, which are described in this specification, don' t fulfill the regulated level. Therefore, the aluminum electrolytic capacitors are not applicable to Export Trade Control Ordinance.

2. Export Trade Control Ordinance (Section 16 of Appendix Table 1)

The aluminum electrolytic capacitors, which are described in this specification, applicable to goods under Export Regulations (Category 85 of Appendix Table in Customs Tariff Law) based on Section 16 of Appendix Table 1 in Export Trade Control Ordinance.

If the exporter got information that their exporting goods are used to any development of massive weapon, the exporter must apply for exporting permission to Ministry of Economy, Trade and Industry (METI), and get METI' s approval.

Regardless of the above, if the exporter is notified by METI that his/her exporting goods are potentially used to any development of extensive destructive weapons, the exporter seek permission from METI to export, and get METI' s approval. When Nippon Chemi-Con receives such notice from METI, we will inform it to your company.

5.4 Cleaning of assembly boards

These products are not solvent-proof type capacitors.

5.5 Manufacturing site

CHEMI-CON IWATE CORPORATION  
P. T. INDONESIA CHEMI-CON  
TAIWAN CHEMI-CON  
SAMYOUNG ELECTRONICS CO., LTD.  
QINGDAO SAMYOUNG ELECTRONICS CO., LTD.  
CHEMI-CON (WUXI) CO., LTD.

6. Marking

The following items shall be marked on each capacitor. (White marking on Brown sleeve)

- ① Rated voltage
- ② Nominal capacitance
- ③ Maximum operating temperature
- ④ Polarity
- ⑤ Manufacturer's identification mark
- ⑥ Capacitance tolerance - (M)
- ⑦ Lot No.

(Example)

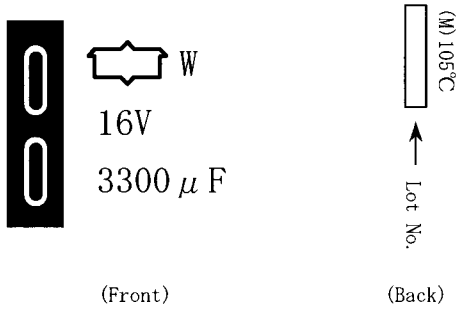

(Front)

(Back)

7. Dimension and construction

7.1 Dimension

Long lead

Lead forming code : L L

unit mm

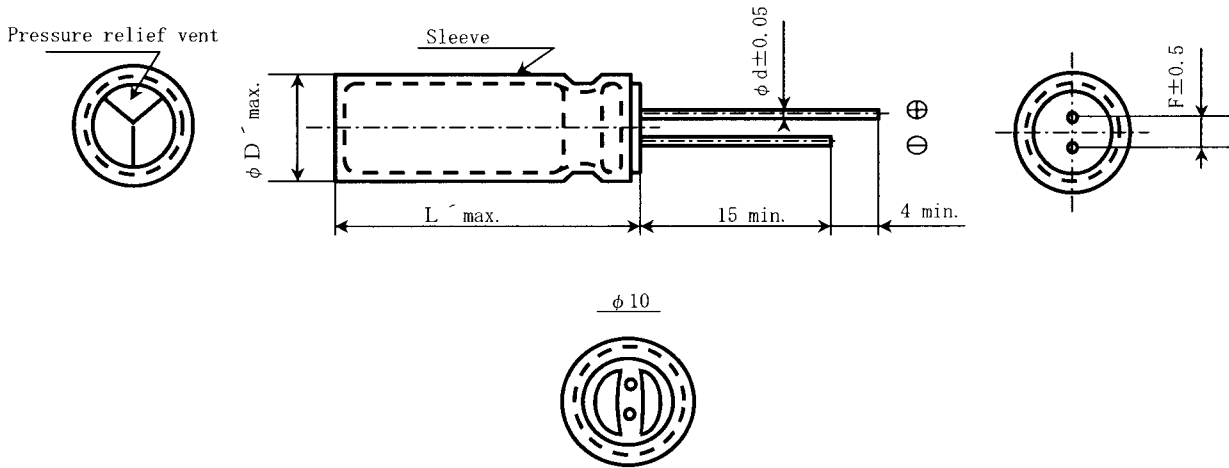

$\phi D$	10
L	35
$\phi d$	0.6
F	5.0
$L \checkmark$	$L + 1.5 \text{ ※1}$
$\phi D \checkmark$	$\phi D + 0.5 \text{ ※1}$

※1  $\phi D, L$  : nominal case size

## 7.2 Construction

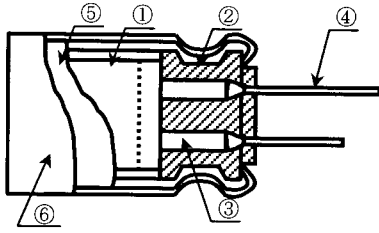

		Compositions	Materials
①	Element	Anode foil	Aluminum
		Cathode foil	Aluminum
		Separator	Paper
		Fixing tape	Polypropylene (PP)
②	Seal		Rubber
③	Aluminum tab		Aluminum
④	Lead wire		Tinned copper clad steel
⑤	Case		Aluminum
⑥	Sleeve		Polyester

※ No ozone depleting substance has been used.  
RoHS Compliant

\*Precautions to User for Non-Solid Aluminum Electrolytic Capacitors\*

CLASSIFICATION	ITEM
1. Designing device circuits.	<p>(1) Make sure that installation and operating environments are within the rated performance limits of capacitors prescribed in their catalogs or product specifications, and select the capacitors to meet the service life of a device. Do not use capacitors at the following conditions,</p> <ul style="list-style-type: none"> <li>a) High temperature (exceeding the maximum rated operating temperature of capacitors)</li> <li>b) Excessive current (more than the rated permissible rated ripple current of the capacitors)</li> <li>c) Over-voltage (exceeding the rated voltage of the capacitors)</li> <li>d) Reverse voltage or AC voltage.</li> <li>e) In circuits in which charge and discharge are frequently repeated.</li> </ul> <p>(2) Electrically isolate the outer can case of a capacitor from the positive and negative terminals and the circuits. If the capacitor has a dummy terminal for mounting stability, isolate it as well.</p> <p>(3) The outer sleeves of capacitors are not assured as insulation -functioning parts. Do not use the capacitors for places that require the outer sleeves functioning as insulation.</p> <p>(4) Do not use capacitors to devices exposed to the following environment.</p> <ul style="list-style-type: none"> <li>a) Water, salt water or oil spatters, or dewy places.</li> <li>b) Toxic gas (hydrogen sulfide, sulfurous acid, nitrous acid, chlorine, ammonium, etc.) fills into.</li> <li>c) Direct sunlight, ozone, ultraviolet rays or radiation is applied to.</li> <li>d) Severe vibration or mechanical shock exceeding the limits prescribed in the catalogs or product specifications is applied to.</li> </ul> <p>(5) Design considerations for installing a capacitor to the print circuit board.</p> <ul style="list-style-type: none"> <li>a) Provide the appropriate hole spacing on the printed circuit board to match the terminal spacing of the capacitor.</li> <li>b) Make an open space over the pressure relief vent of the capacitor.</li> <li>c) Do not locate any wire or copper trace over the vent.</li> <li>d) If mounting the capacitor with its vent face down on the pc board, provide a ventilation hole in the pc board in place. (Application for CE04 type.)</li> <li>e) Do not locate any copper trace under the seal side of a capacitor.</li> <li>f) Avoid locating any heat-producing object around a capacitor or on the reverse side of the print circuit board under the capacitor.</li> <li>g) For surface mount capacitors, design the copper pads of a print circuit board according to the product specifications.</li> </ul> <p>(6) Other precautions in designing devices.</p> <ul style="list-style-type: none"> <li>a) Take account of the changes in the electrical characteristics of capacitors varying with respect to temperature and frequency.</li> <li>b) If using a double-sided printed circuit board, do not locate any via hole within the pc board area under the seal side of the capacitor.</li> <li>c) If using more than one capacitor to connect in parallel, balance the currents flowing into the individual capacitors.</li> <li>d) If using more than one capacitor to connect in series, connect resistors in parallel with the individual capacitors for balancing the voltages.</li> </ul>
2. Installing capacitors in devices.	<p>(1) Follow the instructions below for installing capacitors in devices.</p> <ul style="list-style-type: none"> <li>a) Do not re-use the capacitors already used in devices. The used capacitors are not reusable, except the case that they are taken from a device for periodic inspection measuring their electrical characteristics and then returned to the device.</li> <li>b) Although discharged at manufacturing process, capacitors may have been re-charged by a recovery voltage phenomenon. In this case, discharge them through a resistor of approximately 1 k<math>\Omega</math> before installation.</li> <li>c) The capacitors that has been stored for long periods of time may have high leakage current. In this case, make pre-conditioning by applying a voltage through a resistor of approximately 1k<math>\Omega</math>.</li> <li>d) Make sure of the rated values (nominal capacitance and voltage) and polarity when installation.</li> <li>e) Do not drop capacitors on the floor etc. If they should fall down, do not use them.</li> <li>f) Do not deform capacitors in installing to a device.</li> <li>g) Make sure that the terminal spacing equals the hole spacing of the pc board before installation.</li> <li>h) If the lead wires of the capacitor are clinched to the pc board with the clinch unit of an automatic insertion machine, adjust the clinch unit not to apply an excessive lead pull force to the lead wires of the capacitor.</li> <li>i) Note a mechanical shock that is caused by the vacuum head, component checker or centering operation of an automatic insertion or mounting machine.</li> </ul> <p>(2) Follow the instructions below for soldering.</p> <ul style="list-style-type: none"> <li>a) Do not put flux on any part of capacitors other than their terminals.</li> <li>b) Soldering conditions (temperature, time and the number of repeats) should be within the limits prescribed in the catalogs or product specifications.</li> <li>c) Do not dip the bodies of capacitors into the solder bath.</li> <li>d) Do not let other components lean against the capacitors during soldering.</li> </ul>



CLASSIFICATION	ITEM
2. Installing capacitors in devices.	<p>(3) Do not apply a mechanical stress to the capacitor after soldering to the pc board.</p> <p>a) Do not incline, twist or push the capacitor body.</p> <p>b) Do not take the assembly board by the capacitor in lifting or carrying the assembly board.</p> <p>c) Do not bump or strike any object against the capacitor.</p> <p>(4) Do not wash capacitors by using cleaning agents. If it is necessary to wash capacitors, use the only capacitors that are capable of withstanding the cleaning agents and apply the cleaning conditions within the limits prescribed in the product specifications.</p> <p>(5) Precautions for the washable capacitors.</p> <p>a) Prevent cleaning agents from being contaminated, by controlling their conductivity, pH, specific gravity, water content, etc.</p> <p>b) After washing the capacitors, do not keep them in an atmosphere of the cleaning agents or a closed container. Remove the residual cleaning agents by drying the assembly board by a forced hot air at temperatures less than the maximum rated operating temperature of the capacitors .</p> <p>(6) Do not use any adhesive or coating material containing halogenated solvents.</p> <p>(7) Precautions for using adhesives and coating materials.</p> <p>a) Do not apply adhesives or coating materials with flux or dirt left on the rubber seal of the capacitor or between the pc board surface and the capacitor seal.</p> <p>b) Before applying the adhesives or coating materials to the capacitors, dry and remove the residual cleaning agents. Also, do not cover up the whole surface of the capacitor rubber seal with the adhesives or coating materials.</p> <p>c) For permissible heat conditions for curing adhesives or coating materials, follow the instructions in the product specifications of capacitors.</p>
3. During operation.	<p>(1) Follow the following precautions for a device in operation.</p> <p>a) Do not touch a capacitor directly with bare hands.</p> <p>b) Do not short-circuit the terminals of a capacitor by applying any conductive object.</p> <p>(2) Do not use devices at the following environment.</p> <p>a) Water, oil or dew spatters on the capacitors.</p> <p>b) Direct sunlight, ozone, ultraviolet rays or radiation is applied to the capacitors.</p> <p>c) Toxic gas (hydrogen sulfide, sulfurous acid, nitrous acid, chlorine, ammonium, etc.) fills into.</p> <p>d) Severe vibration or mechanical shock, exceeding the limits prescribed in the catalogs or product specifications, is applied to the capacitors.</p>
4. Maintenance inspection.	<p>(1) Make periodic inspections for the capacitors that have been used in devices for industrial application. The appearance and electrical characteristics of the capacitors should be checked for the periodic inspections.</p>
5. In the event of venting on capacitors.	<p>(1) If the capacitor should blow out gas with its vent open, turn off or unplug the main power supply of the device.</p> <p>(2) When venting, the capacitor blows a hot gas of more than 100°C. Never expose the face close to the venting capacitor. If you should expose your eyes to the spouting gas and inhale it, immediately flush the open eyes and gargle with water. Do not lick the electrolyte of a capacitor. Wash the electrolyte away from the skin with soap and water.</p>
6. Fumigation.	<p>(1) Fumigation process may be required when exporting the end electrical product. The process, actually halogenated ions, may cause the aluminum electrolytic capacitor to corrode. The fumigation solvent must not directly adhere to the electrical product and the solvent must be dried completely. Please consult us if solvent adheres to the aluminum electrolytic capacitors or drying condition is not satisfaction.</p>
7. Storage.	<p>(1) Store capacitors indoors at a temperature of 5 to 35°C and a humidity of less than 75%RH.</p> <p>(2) Do not store capacitors in the environment prohibited with Section 3. (2).</p>
8. Disposal.	<p>(1) In the interests of the environment and in order to comply with local disposal regulations, ask a specialist for the disposal of industrial wastes.</p>

\* For other precautions and the details of these precautions, refer to Engineering Bulletin No. 634A. The following technical terms have been changed according to change of reference standard from JIS C 5141-1991 to JIS C 5101-1998.

New standard JIS C 5101-1998	Old standard JIS C 5141-1991
Category temperature range	Operating temperature range
Rated ripple current	Ripple current
Endurance	Load life

## X-ON Electronics

Largest Supplier of Electrical and Electronic Components

*Click to view similar products for* [Aluminium Electrolytic Capacitors - Radial Leaded](#) *category:*

*Click to view products by* [Nippon Chemi-Con](#) *manufacturer:*

Other Similar products are found below :

[LXY50VB4.7M-5X11](#) [RFO-100V471MJ7P#](#) [ECE-A1EGE220](#) [B41041A7226M8](#) [B41044A7157M6](#) [NCD681K10KVY5PF](#)

[NEV1000M25EF-BULK](#) [NEV100M35DC](#) [NEV100M63DE](#) [NEV220M25DD-BULK](#) [NEV.33M100AA](#) [NEV4700M50HB](#) [NEV.47M100AA](#)

[NEVH1.0M250AB](#) [NEVH3.3M250BB](#) [NEVH3.3M450CC](#) [KME50VB100M-8X11.5](#) [SG220M1CSA-0407](#) [ES5107M016AE1DA](#)

[ESMG160ETD102MJ16S](#) [ESX472M16B](#) [227RZS050M](#) [476CKH100MSA](#) [477RZS050M](#) [B41793A9108Q1](#) [UVX1V101KPA1FA](#)

[UVX1V222MHA1CA](#) [KME25VB100M-6.3X11](#) [VTL100S10](#) [VTL470S10](#) [VTL470S16A](#) [511D336M250EK5D](#) [052687X](#) [ECE-A1CF471](#)

[NRE-S560M16V6.3X7TBSTF](#) [RGA221M1CTA-0611G](#) [ERZA630VHN182UP54N](#) [UPL1A331MPH](#) [SK035M0100AZS-0611](#)

[NEV1000M6.3DE](#) [NEV100M16CB](#) [NEV100M50DD-BULK](#) [NEV2200M16FF](#) [NEV220M50EE](#) [NEV2.2M50AA](#) [NEV330M63EF](#)

[NEV4700M35HI](#) [NEV4.7M100BA](#) [NEV47M16BA](#) [NEV47M50CB-BULK](#)