

ADJUSTABLE PRECISION SHUNT REGULATOR

■FEATURES

- Operating Voltage V_{REF} to 36V
- Precision Voltage Reference $2.495V \pm 0.8\%$
 $2.5V \pm 0.8\%$
- Adjustable Output Voltage by external resistance
- Wide Safety Operating Boundary Area
- Bipolar Technology
- Package SOT-23-5
SOT-89-3

■APPLICATION

- Industrial Equipment
- Home Electrical Appliance
- Replacement from Zener Diode
- Other

■GENERAL DESCRIPTION

The NJM17431 is adjustable precision shunt regulator. The output voltage may be set to any value between V_{REF} (about 2.5V) and 36V by two external resistors.

The NJM17431 is improved the reference voltage accuracy ($\pm 0.8\%$) and safety operating boundary area connected large capacitance. Therefore, the NJM17431 is suitable for various applications.

■BLOCK DIAGRAM

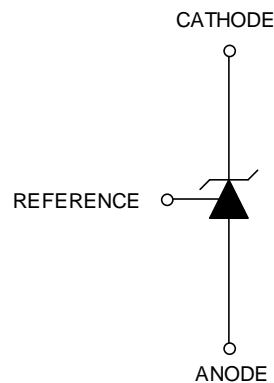
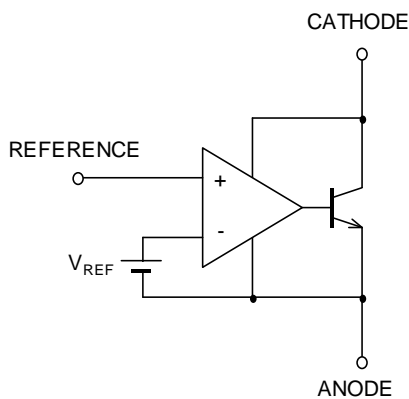

■PIN CONFIGURATION

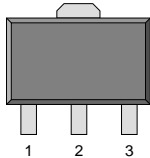
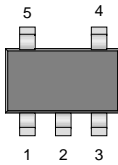
Pin Assign	 <p>1. REFERENCE 2. ANODE 3. CATHODE</p>	 <p>1. REFERENCE 2. ANODE 3. CATHODE 4. N.C. 5. N.C.</p>	
	Package	SOT-89-3	SOT-23-5
Product Number	NJM17431Uxx	NJM17431FxxA	

■PRODUCT NAME INFORMATION

NJM17431		-	U/F	-	24/25	-	A	-	(TE1)
Part Number	Package		V _{REF}		Pin assign		Taping Form		
	U: SOT-89-3 F: SOT-23-5		24: 2.495V 25: 2.5V		Option				

■ORDERING INFORMATION

PRODUCT NAME	PACKAGE	RoHS	HALOGEN-FREE	TERMINAL FINISH	MARKING	WEIGHT (mg)	MOQ (pcs)
NJM17431U24	SOT-89-3	Yes	Yes	Sn2Bi	181	61	1,000
NJM17431U25	SOT-89-3	Yes	Yes	Sn2Bi	171	61	1,000
NJM17431F24A	SOT-23-5	Yes	Yes	Sn2Bi	AK5x ("x" is Lot)	15	3,000
NJM17431F25A	SOT-23-5	Yes	Yes	Sn2Bi	AK4x ("x" is Lot)	15	3,000

■ABSOLUTE MAXIMUM RATINGS

PARAMETER	SYMBOL	MAXIMUM RATINGS	UNIT	REMARK	
Cathode Voltage	V_{KA}	+37 (1)	V	ANODE-CATHODE Pin	
Continuous Cathode Current	I_K	- 100 to +150	mA	ANODE-CATHODE Pin	
Reference Input Current	I_{REF}	- 0.05 to +10	mA	-	
Power Dissipation	P_D	SOT-23-5	480 (2) 650 (3)	mW	-
		SOT-89-3	450 (4) 1300 (5)		
Junction Temperature	T_{jmax}	+150	°C	-	
Operating Temperature Range	T_{opr}	- 40 to +125	°C	-	
Storage Temperature Range	T_{stg}	- 50 to +150	°C	-	

(1) Unless specified, all voltage value are with respect to the anode pin.

(2) Mounted on glass epoxy board. (76.2×114.3×1.6mm: based on EIA/JEDEC standard, 2Layers)

(3) Mounted on glass epoxy board. (76.2×114.3×1.6mm: based on EIA/JEDEC standard, 4Layers),

internal Cu area: 74.2×74.2mm

(4) Mounted on glass epoxy board. (76.2×114.3×1.6mm: based on EIA/JEDEC standard size, 2Layers)

(5) Mounted on glass epoxy board. (76.2×114.3×1.6mm: based on EIA/JEDEC standard, 4Layers)

(For 4Layers: Applying 74.2×74.2mm inner Cu area and a thermal via hole to a board based on JEDEC standard JESD51-5)

■RECOMMENDED OPERATING CONDITIONS

PARAMETER	SYMBOL	RATINGS	UNIT	REMARK
Cathode Voltage	V_{KA}	V_{REF} to 36	V	ANODE-CATHODE Pin
Cathode Current	I_K	0.5 to 100	mA	ANODE-CATHODE Pin

■ ELECTRICAL CHARACTERISTICS

(Unless other noted, $I_K=10\text{mA}$, $T_a=25^\circ\text{C}$)

PARAMETER	SYMBOL	TEST CONDITIONS	MIN.	TYP.	MAX.	UNIT	
Reference Voltage	V_{REF}	$V_{KA}=V_{REF}$ (6)	2.495V ver.	2.475	2.495	2.515	V
			2.5V ver.	2.480	2.500	2.520	
Reference Input Voltage Change Over Temperature Range	ΔV_{REF} (dev)	$V_{KA}=V_{REF}$ (6) $T_a=-40^\circ\text{C}$ to $+85^\circ\text{C}$	-	8	17	mV	
Reference voltage temperature coefficient	ΔV_{REF} (ppm)	$V_{KA}=V_{REF}$ (6) $T_a=-40^\circ\text{C}$ to $+85^\circ\text{C}$	-	± 30	-	ppm/ $^\circ\text{C}$	
Reference Voltage Change vs. Cathode Voltage Change	$\frac{\Delta V_{REF}}{\Delta V_{KA}}$	$\Delta V_{KA}=10\text{V}-V_{REF}$ (7) $\Delta V_{KA}=36\text{V}-10\text{V}$	-	-2.0 -1	-3.7 -2.2	mV/V	
Reference Input Current	I_{REF}	$R1=10\text{k}\Omega$, $R2=\infty$ (7)	-	1	2.8	μA	
Reference Input Current Change Over Temperature Range	ΔI_{REF} (dev)	$R1=10\text{k}\Omega$, $R2=\infty$ (7) $T_a=-40^\circ\text{C}$ to $+85^\circ\text{C}$	-	0.25	0.5	μA	
Minimum Cathode Current	I_{MIN}	$V_{KA}=V_{REF}$ (6)	-	0.25	0.5	mA	
OFF State Cathode Current	I_{OFF}	$V_{KA}=36\text{V}$, $V_{REF}=0\text{V}$ (8)	-	0.1	1.0	μA	
Dynamic Impedance	$ Z_{KA} $	$V_{KA}=V_{REF}$, $I_K=1\text{mA}$ to 100mA , $f \leq 1\text{kHz}$ (6)	-	0.2	0.5	Ω	

The maximum value of “Dynamic Impedance”, “Reference Voltage Change” and “Reference Input Current Change” are determined based on sampling evaluation from the initial production lots, and thus not tested in the production test.

Therefore, these values are for the reference design purpose only.

(6): TestCircuitFig.1

(7): Test CircuitFig.2

(8): Test Circuit Fig.3

■ TEST CIRCUIT

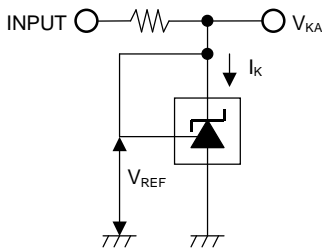

Fig.1. Test Circuit for $V_{KA}=V_{REF}$

$$V_O = V_{KA} = V_{REF}$$

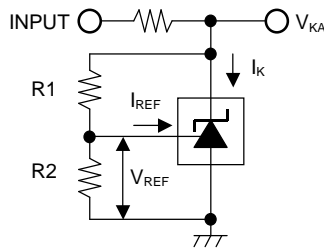

Fig.2. Test Circuit for $V_{KA} > V_{REF}$

$$V_O = V_{KA} = V_{REF} \left(1 + \frac{R1}{R2} \right) + I_{REF} \times R1$$

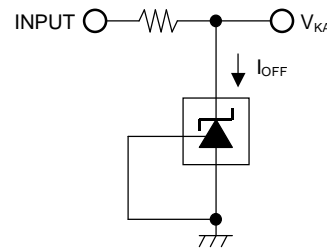

Fig.3. Test Circuit for I_{OFF}

■ THERMAL CHARACTERISTICS

PARAMETER	SYMBOL	VALUE		UNIT
Junction-to-ambient thermal resistance	θ_{ja}	SOT-23-5	260 (2) 195 (3)	$^{\circ}\text{C}/\text{W}$
		SOT-89-3	200 (4) 130 (5)	
Junction-to-Top of package characterization parameter	ψ_{jt}	SOT-23-5	60 (2) 70 (3)	$^{\circ}\text{C}/\text{W}$
		SOT-89-3	67 (4) 65 (5)	

(2) Mounted on glass epoxy board. (76.2x114.3x1.6mm: based on EIA/JEDEC standard, 2Layers)

(3) Mounted on glass epoxy board. (76.2x114.3x1.6mm: based on EIA/JEDEC standard, 4Layers),

internal Cu area: 74.2x74.2mm

(4) Mounted on glass epoxy board. (76.2x114.3x1.6mm: based on EIA/JEDEC standard size, 2Layers)

(5) Mounted on glass epoxy board. (76.2x114.3x1.6mm: based on EIA/JEDEC standard, 4Layers)

(For 4Layers: Applying 74.2x74.2mm inner Cu area and a thermal via hole to a board based on JEDEC standard JESD51-5)

■ POWER DISSIPATION vs. AMBIENT TEMPERATURE

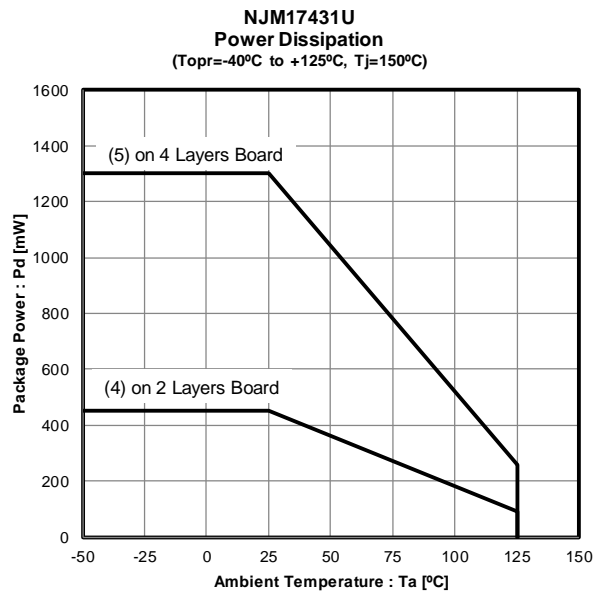
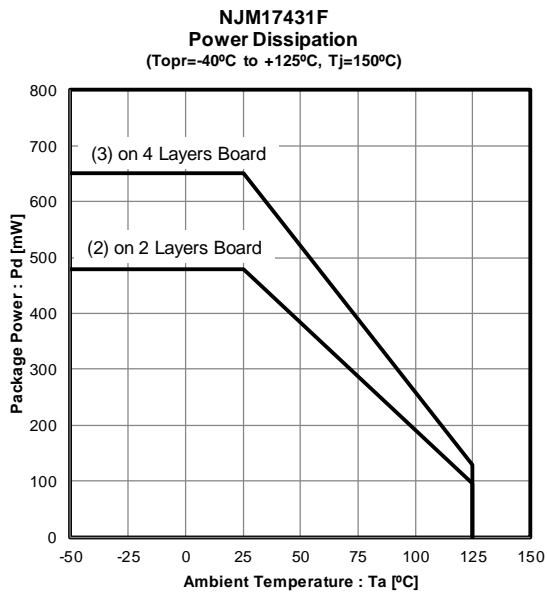

■ TYPICAL CHARACTERISTICS

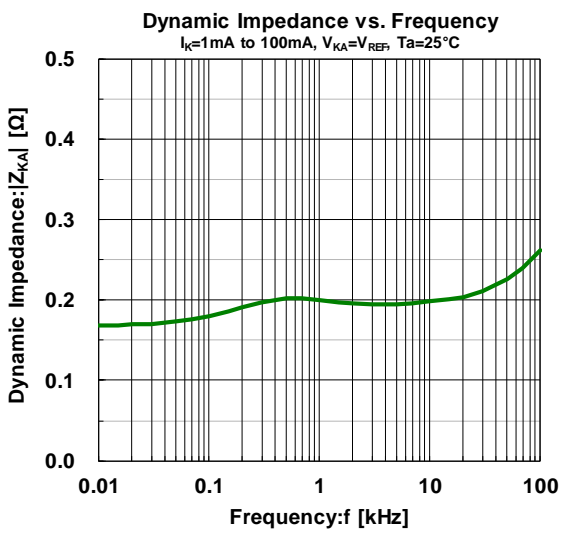
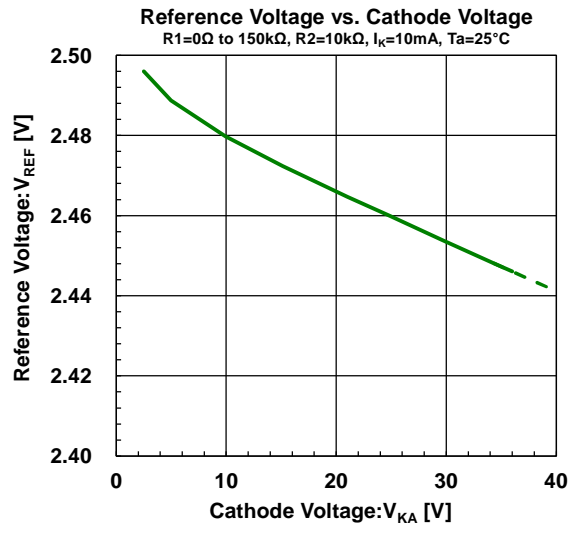
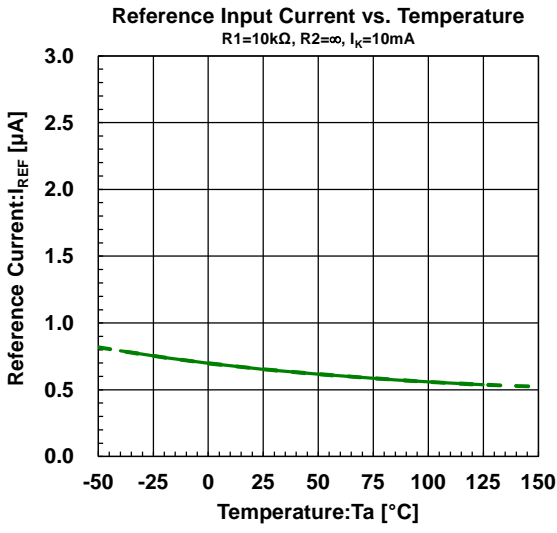
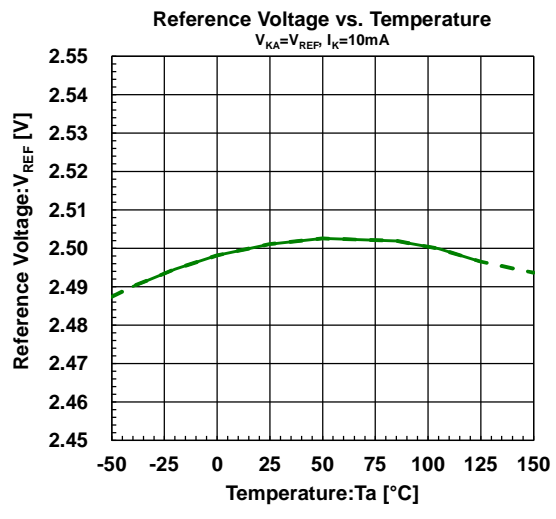
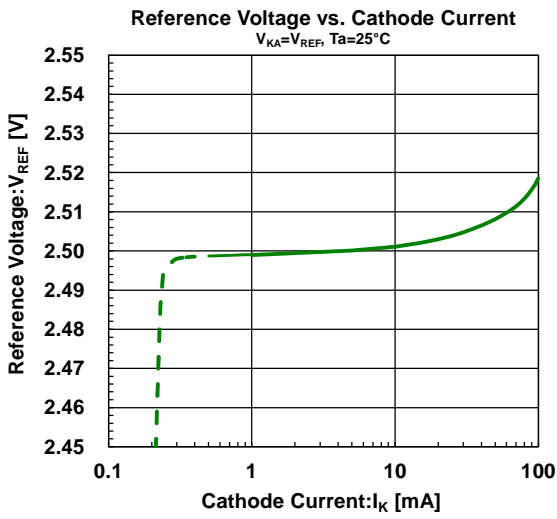

■ TYPICAL CHARACTERISTICS

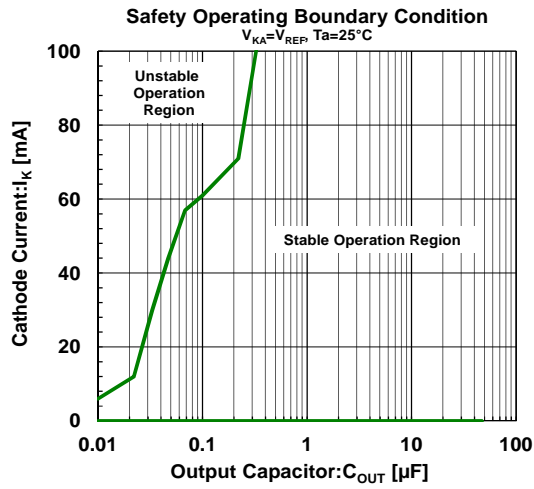

Safety Operating Boundary Condition Test Circuit

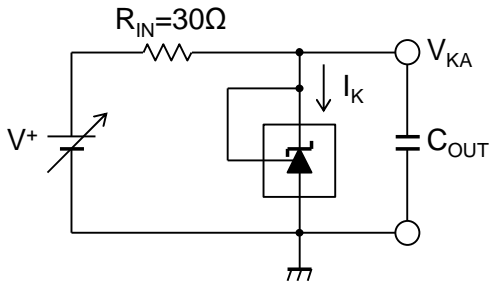

Note) Oscillation might occur while operating within the range of safety curve.
 So that, it is necessary to make ample margins by taking considerations of fluctuation of the device.

PACKAGE DIMENSIONS

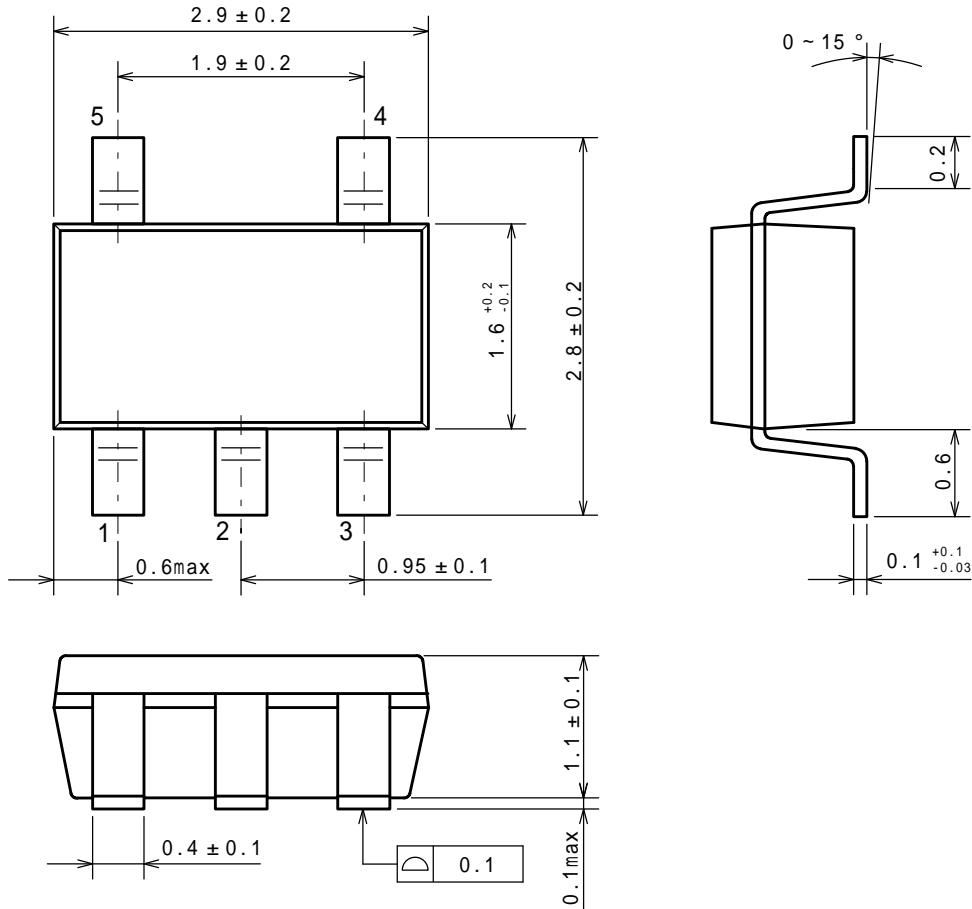

EXAMPLE OF SOLDER PADS DIMENSIONS

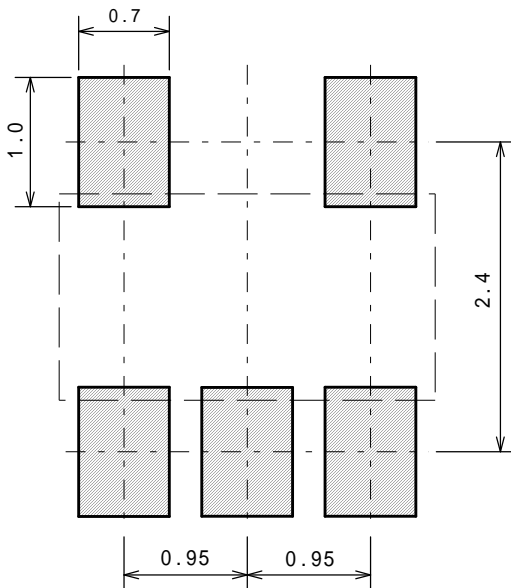

PACKAGE DIMENSIONS

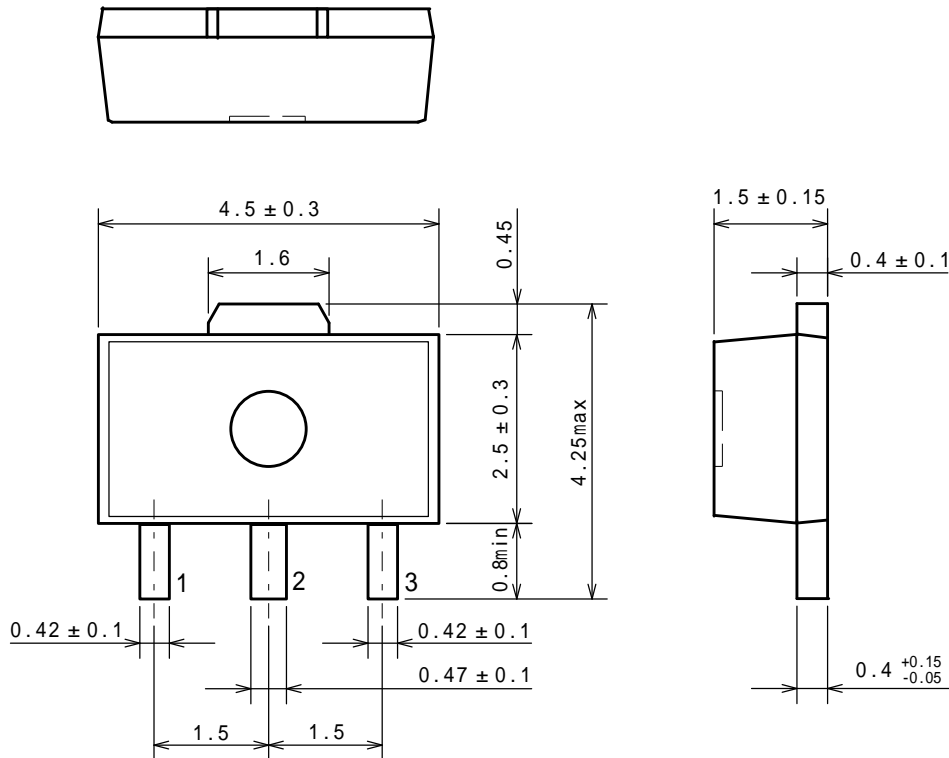

EXAMPLE OF SOLDER PADS DIMENSIONS

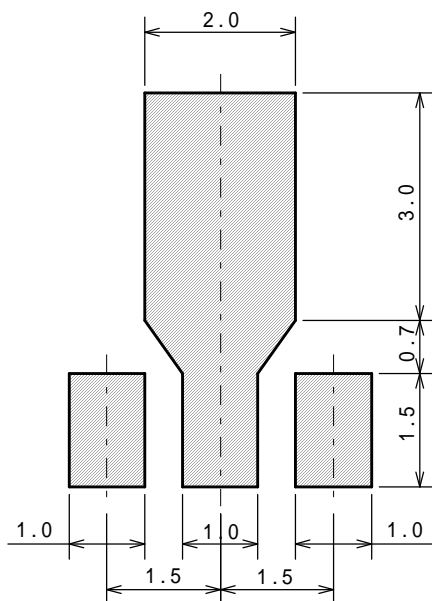

PACKING SPEC

TAPING DIMENSIONS

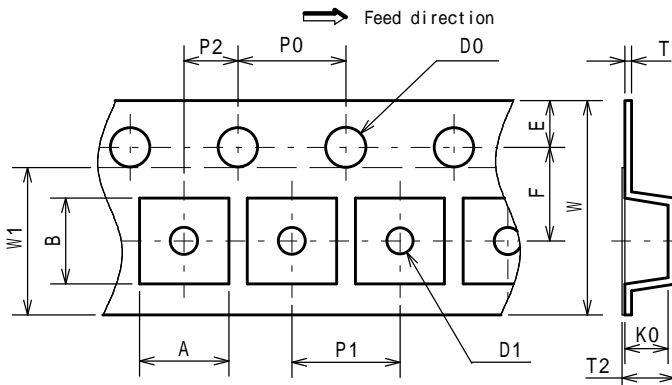

SYMBOL	DIMENSION	REMARKS
A	3.3 ± 0.1	BOTTOM DIMENSION
B	3.2 ± 0.1	BOTTOM DIMENSION
D0	1.55	
D1	1.05	
E	1.75 ± 0.1	
F	3.5 ± 0.05	
P0	4.0 ± 0.1	
P1	4.0 ± 0.1	
P2	2.0 ± 0.05	
T	0.25 ± 0.05	
T2	1.82	
K0	1.5 ± 0.1	
W	8.0 ± 0.3	
W1	5.5	THICKNESS 0.1MAX

REEL DIMENSIONS

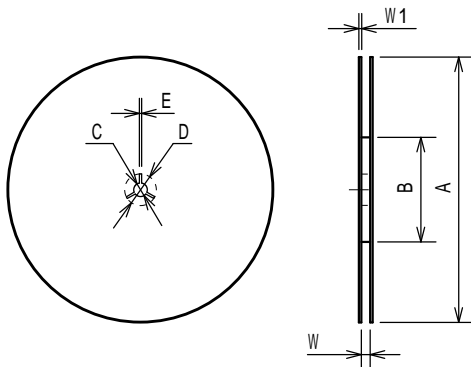

SYMBOL	DIMENSION
A	180 ± 1
B	60 ± 1
C	13 ± 0.2
D	21 ± 0.8
E	2 ± 0.5
W	9 ± 0.5
W1	1.2 ± 0.2

TAPING STATE

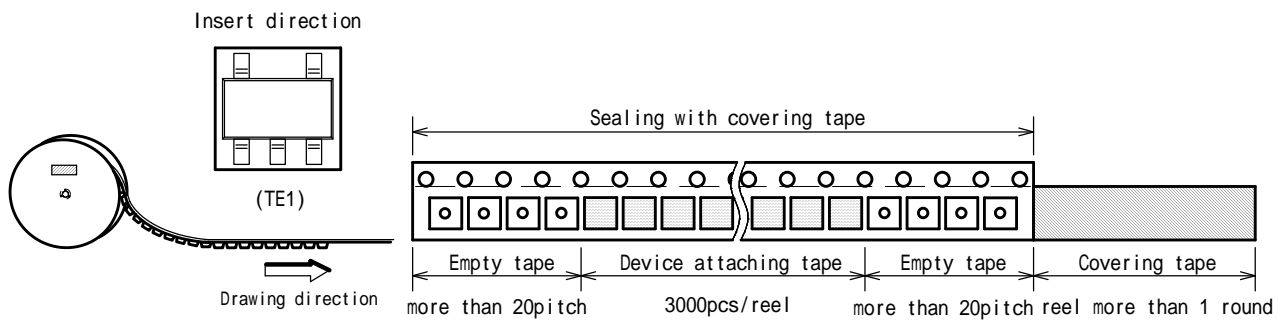

PACKING STATE

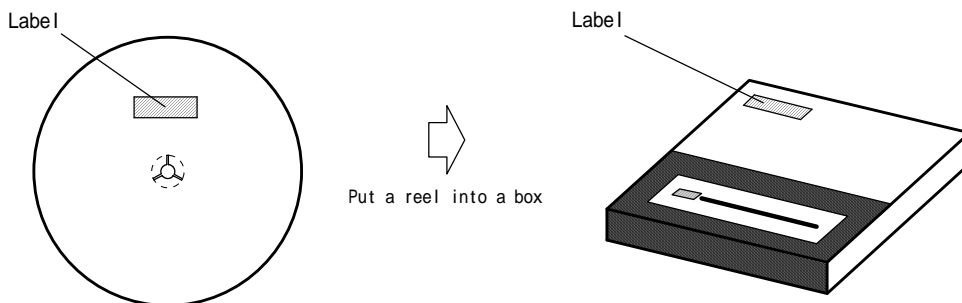

PACKING SPEC

TAPING DIMENSIONS

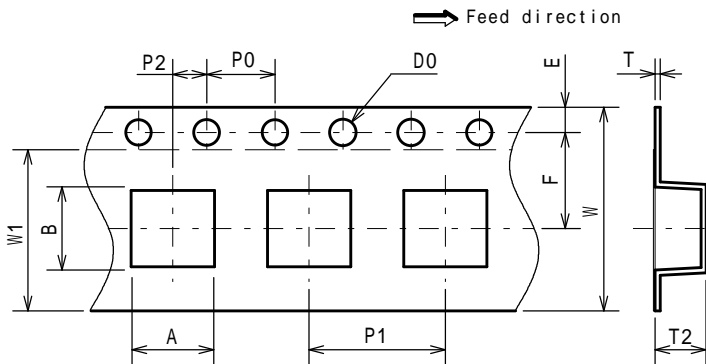

SYMBOL	DIMENSION	REMARKS
A	4.9 ± 0.1	BOTTOM DIMENSION
B	4.5 ± 0.1	BOTTOM DIMENSION
D0	1.5 ^{+0.1} ₀	
E	1.5 ± 0.1	
F	5.65 ± 0.1	
P0	4.0 ± 0.1	
P1	8.0 ± 0.1	
P2	2.0 ± 0.05	
T	0.3 ± 0.05	
T2	2.0	
W	12.0 ± 0.3	
W1	9.5	THICKNESS 0.1MAX

REEL DIMENSIONS

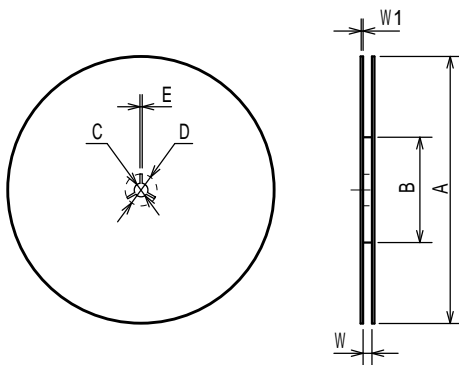

SYMBOL	DIMENSION
A	180 ± 1
B	60 ± 1
C	13 ± 0.2
D	21 ± 0.8
E	2 ± 0.5
W	13 ± 0.5
W1	1.2 ± 0.2

TAPING STATE

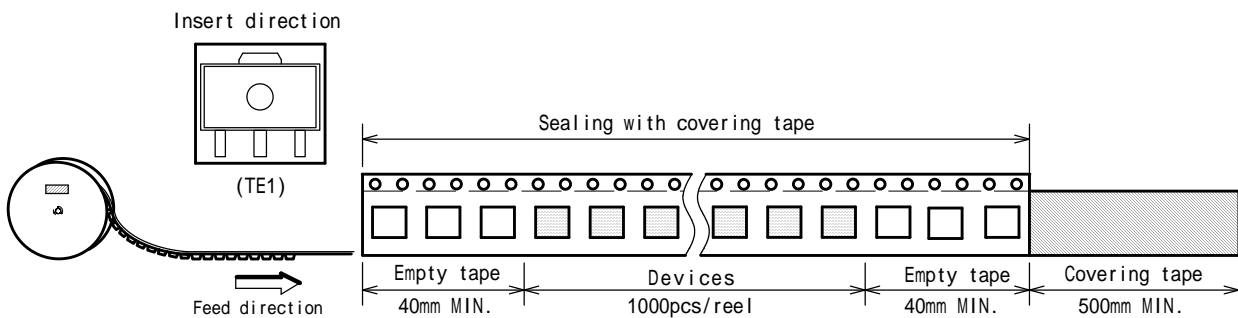

PACKING STATE

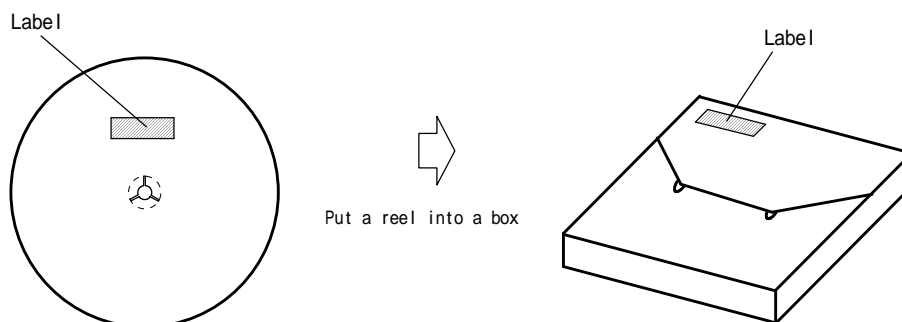

RECOMMENDED MOUNTING METHOD

INFRARED REFLOW SOLDERING METHOD

* Recommended reflow soldering procedure

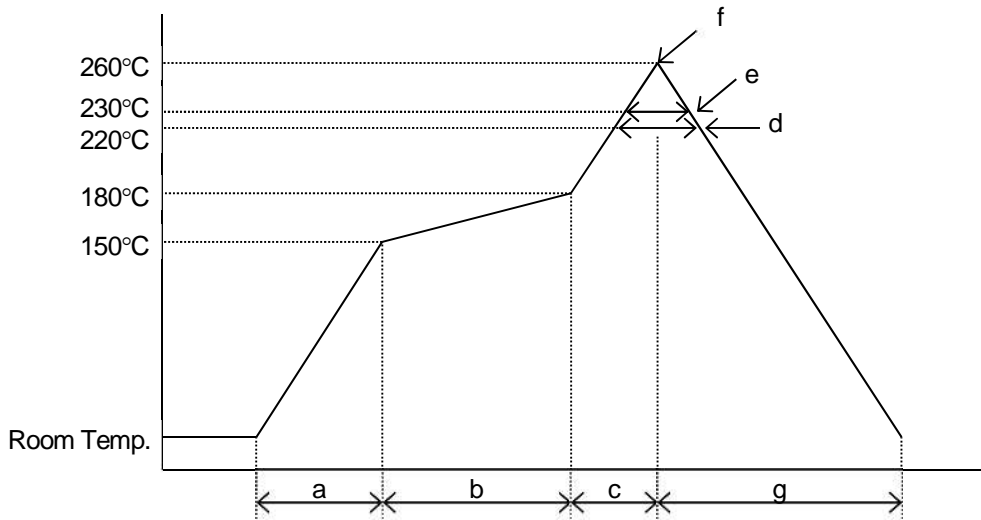

- | | |
|-----------------------------|--------------------|
| a: Temperature ramping rate | : 1 to 4°C /s |
| b: Pre-heating temperature | : 150 to 180°C |
| time | : 60 to 120s |
| c: Temperature ramp rate | : 1 to 4°C /s |
| d: 220°C or higher time | : Shorter than 60s |
| e: 230°C or higher time | : Shorter than 40s |
| f: Peak temperature | : Lower than 260°C |
| g: Temperature ramping rate | : 1 to 6°C /s |

The temperature indicates at the surface of mold package.

■REVISION HYSTORY

Date	Revision	Changes
21.May.2020	Ver.1.0	New Release
16.Sep.2020	Ver.1.1	Added NJM17431F24A
16.Sep.2021	Ver.1.2	Added NJM17431Uxx

[CAUTION]

1. NJR strives to produce reliable and high quality semiconductors. NJR's semiconductors are intended for specific applications and require proper maintenance and handling. To enhance the performance and service of NJR's semiconductors, the devices, machinery or equipment into which they are integrated should undergo preventative maintenance and inspection at regularly scheduled intervals. Failure to properly maintain equipment and machinery incorporating these products can result in catastrophic system failures
2. The specifications on this datasheet are only given for information without any guarantee as regards either mistakes or omissions. The application circuits in this datasheet are described only to show representative usages of the product and not intended for the guarantee or permission of any right including the industrial property rights.
All other trademarks mentioned herein are the property of their respective companies.
3. To ensure the highest levels of reliability, NJR products must always be properly handled.
The introduction of external contaminants (e.g. dust, oil or cosmetics) can result in failures of semiconductor products.
4. NJR offers a variety of semiconductor products intended for particular applications. It is important that you select the proper component for your intended application. You may contact NJR's Sale's Office if you are uncertain about the products listed in this datasheet.
5. Special care is required in designing devices, machinery or equipment which demand high levels of reliability. This is particularly important when designing critical components or systems whose failure can foreseeably result in situations that could adversely affect health or safety. In designing such critical devices, equipment or machinery, careful consideration should be given to amongst other things, their safety design, fail-safe design, back-up and redundancy systems, and diffusion design.
6. The products listed in this datasheet may not be appropriate for use in certain equipment where reliability is critical or where the products may be subjected to extreme conditions. You should consult our sales office before using the products in any of the following types of equipment.
 - Aerospace Equipment
 - Equipment Used in the Deep Sea
 - Power Generator Control Equipment (Nuclear, steam, hydraulic, etc.)
 - Life Maintenance Medical Equipment
 - Fire Alarms / Intruder Detectors
 - Vehicle Control Equipment (Airplane, railroad, ship, etc.)
 - Various Safety Devices
7. NJR's products have been designed and tested to function within controlled environmental conditions. Do not use products under conditions that deviate from methods or applications specified in this datasheet. Failure to employ the products in the proper applications can lead to deterioration, destruction or failure of the products. NJR shall not be responsible for any bodily injury, fires or accident, property damage or any consequential damages resulting from misuse or misapplication of the products. The products are sold without warranty of any kind, either express or implied, including but not limited to any implied warranty of merchantability or fitness for a particular purpose.
8. Warning for handling Gallium and Arsenic (GaAs) Products (Applying to GaAs MMIC, Photo Reflector). These products use Gallium (Ga) and Arsenic (As) which are specified as poisonous chemicals by law. For the prevention of a hazard, do not burn, destroy, or process chemically to make them as gas or power. When the product is disposed of, please follow the related regulation and do not mix this with general industrial waste or household waste.
9. The product specifications and descriptions listed in this datasheet are subject to change at any time, without notice.



X-ON Electronics

Largest Supplier of Electrical and Electronic Components

Click to view similar products for [Voltage References](#) category:

Click to view products by [Nisshinbo](#) manufacturer:

Other Similar products are found below :

[REF01J/883](#) [5962-8686103XC](#) [NCV431BVDMR2G](#) [LT6654AMPS6-2.048#TRMPBF](#) [SCV431AIDMR2G](#) [LT1019AIS8-2.5](#)
[LT6654AMPS6-3.3#TRM](#) [SC431ILPRAG](#) [AP432AQG-7](#) [NJM2823F-TE1](#) [TL431-A](#) [MCP1502T-18E/CHY](#) [MCP1502T-40E/CHY](#)
[TL431ACZ](#) [KA431SLMF2TF](#) [KA431SMF2TF](#) [KA431SMFTF](#) [LM4040QCEM3-3.0/NOPB](#) [LM4041C12ILPR](#) [LM4120AIM5-2.5/NOP](#)
[LM431SCCMFX](#) [TS3330AQPR](#) [REF5040MDREP](#) [REF3012AIDBZR](#) [LM285BXXMX-1.2/NOPB](#) [LM385BM-2.5/NOPB](#) [LM4040AIM3-10.0](#)
[LM4040BIM3-4.1](#) [LM4040CIM3-10.0](#) [LM4040CIM3X-2.0/NOPB](#) [LM4041BSD-122GT3](#) [LM4041QDIM3-ADJ/NO](#)
[LM4050QAEM3X4.1/NOPB](#) [LM4051BIM3-ADJ/NOPB](#) [LM4051CIM3X-1.2/NOPB](#) [LM4128CMF-1.8/NOPB](#) [LM4132DMF-1.8/NOPB](#)
[LM4132EMF-1.8/NOPB](#) [LM4132EMF-2.0/NOPB](#) [LM4140CCMX-1.2/NOPB](#) [LM431CIM](#) [LM385BD-2.5R2G](#) [LM385M-2.5/NOPB](#)
[LM4030AMF-4.096/NOPB](#) [LM4040D30ILPR](#) [LM4051CIM3X-ADJ/NOPB](#) [AP432YG-13](#) [AS431ANTR-G1](#) [AS431BZTR-E1](#) [AN431AN-
ATRG1](#)