

## Designated client product

This product will be discontinued its production in the near term.  
And it is provided for customers currently in use only, with a time limit.  
It can not be available for your new project. Please select other new or existing products.

For more information, please contact our sales office in your region.

New Japan Radio Co.,Ltd.

[www.njr.com](http://www.njr.com)

## SYSTEM RESET IC

### ■ GENERAL DESCRIPTION

**NJM2103** is supply voltage supervisory IC to detect the abnormal conditions, such as shut down of all supply voltages at once, or sudden voltage down and then generate the reset signal. It supervises both 5V supply voltage and the voltage optionally set up.

### ■ PACKAGE OUTLINE

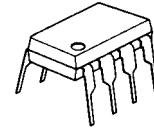

**NJM2103D**



**NJM2103M**

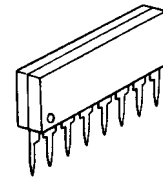

**NJM2103L**

### ■ FEATURES

- Precise Detection of Supply Voltage Down ( $V_{SA}=4.2V\pm 2.5\%$ )
- Possible Detection of Optional Voltage Down ( $V_{SB}=1.22V\pm 1.5\%$ )
- Possible Detection of Optional Over-loading ( $I_{CC}\leq 560\mu A@V_{SB}=5V$ )
- Low Operating Current ( $V^+=0.8V$  Typ.)
- Reference Voltage can be taken out.
- Low Reset Validated Voltage (DIP8, DMP8, SIP8)
- Voltage Detection with Hysteresis Feature
- Package Outline
- Bipolar Technology

### ■ PIN CONFIGURATION

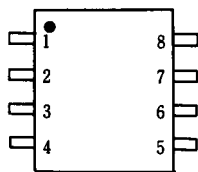

**NJM2103D**  
**NJM2103M**

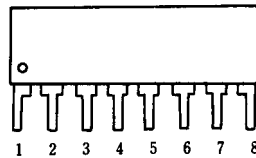

**NJM2103L**

### PIN FUNCTION

1.  $C_T$
2.  $V_{SC}$
3.  $OUT_C$
4. GND
5.  $V^+$
6.  $V_{SB}/RESIN$
7.  $V_{SA}$
8.  $\overline{RESET}$

### ■ BLOCK DIAGRAM

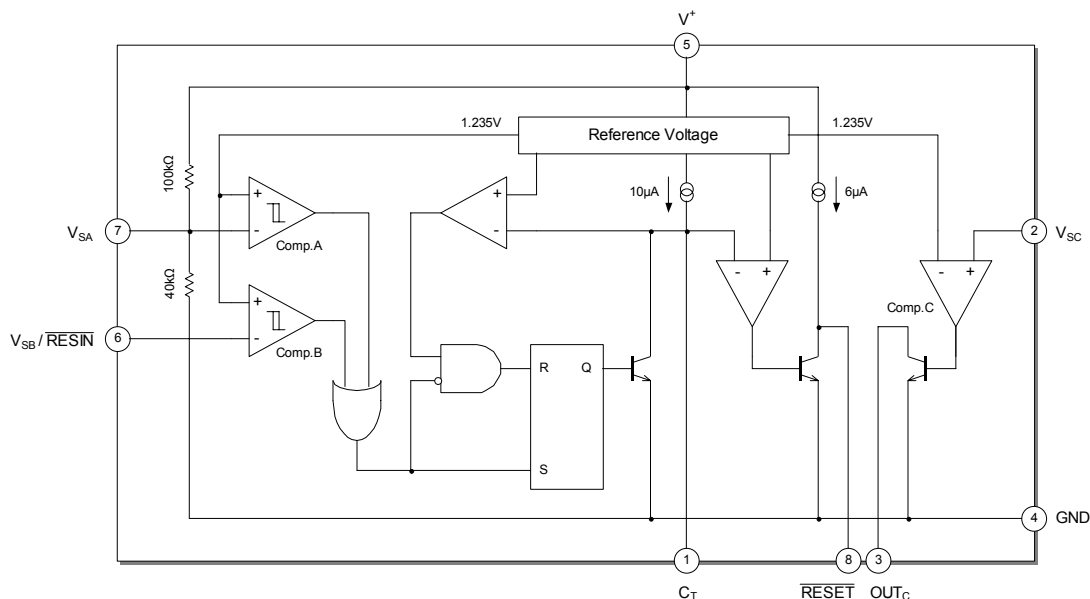

# NJM2103

## ■ ABSOLUTE MAXIMUM RATINGS

( $T_a=25^\circ\text{C}$ )

PARAMETER	SYMBOL	RATINGS	UNIT
Supply Voltage	$V^+$	20	V
Power Dissipation	$P_D$	(DIP8) 500 (DMP8) 300 (SIP8) 800	mW mW mW
Input Voltage A	$V_{SA}$	$V^+ + 0.3 (<20)$	V
Input Voltage B	$V_{SB}$	20	V
Input Voltage C	$V_{SC}$	20	V
Operating Temperature Range	$T_{opr}$	-40 to +85	$^\circ\text{C}$
Storage Temperature Range	$T_{stg}$	-40 to +125	$^\circ\text{C}$

## ■ ELECTRICAL CHARACTERISTICS

### ● DC CHARACTERISTICS

( $V^+=5.0\text{V}$ ,  $V_{SB}=0\text{V}$ ,  $V_{SC}=0\text{V}$ ,  $T_a=25^\circ\text{C}$ )

PARAMETER	SYMBOL	CONDITION	MIN.	TYP.	MAX.	UNIT
Operating Current (1)	$I_{CC1}$	$V_{SB}=5\text{V}$	-	380	560	$\mu\text{A}$
Operating Current (2)	$I_{CC2}$		-	460	700	$\mu\text{A}$
$V_{SA}$ Detecting Voltage (1)	$V_{SAL}$	$V^+$ fall time $V_{SB}=V^+$	4.10	4.20	4.30	V
$V_{SA}$ Detecting Voltage (2)	$V_{SAH}$	$V^+$ rise time $V_{SB}=V^+$	4.20	4.30	4.40	V
$V_{SA}$ Hysteresis Width	$V_{HRSA}$		50	100	150	mV
$V_{SB}$ Detecting Voltage	$V_{SBL}$	$V_{SB}$ fall time	1.202	1.220	1.238	V
$V_{SB}$ Detecting Supply Voltage Fluctuation	$\Delta V_{SBL}$	$V^+=3.5$ to $18\text{V}$	-	3	10	mV
$V_{SB}$ Hysteresis Width	$V_{HRSB}$		14	28	42	mV
$V_{SB}$ Input Current (1)	$I_{IHB}$	$V_{SB}=5\text{V}$	-	0	250	nA
$V_{SB}$ Input Current (2)	$I_{ILB}$		-	20	250	nA
High Level $\overline{\text{RESET}}$ Output Voltage	$V_{OHR}$	$I_{\overline{\text{RESET}}}=-5\mu\text{A}$ , $V_{SB}=5\text{V}$	4.5	4.9	-	$\mu\text{V}$
$\overline{\text{RESET}}$ Output Saturating Voltage (1)	$V_{OLR1}$	$I_{\overline{\text{RESET}}}=2\text{mA}$	-	0.20	0.40	V
$\overline{\text{RESET}}$ Output Saturating Voltage (2)	$V_{OLR2}$	$I_{\overline{\text{RESET}}}=10\text{mA}$	-	0.30	0.50	V
$\overline{\text{RESET}}$ Output Sink Current	$I_{\overline{\text{RESET}}}$	$V_{OLR}=1.0\text{V}$	20	80	-	mA
$C_T$ Charge Current	$I_{CT}$	$V_{SB}=5\text{V}$ , $V_{CT}=0.5\text{V}$	6.0	9.5	13.0	$\mu\text{A}$
$V_{SC}$ Input Current (1)	$I_{IHC}$	$V_{SC}=5\text{V}$	-	0	500	nA
$V_{SC}$ Input Current (2)	$I_{ILC}$		-	50	500	nA
$V_{SC}$ Detecting Voltage	$V_{SC}$		1.215	1.235	1.255	V
$V_{SC}$ Detecting Supply Voltage Fluctuation	$\Delta V_{SC}$	$V^+=3.5$ to $13.5\text{V}$	-	3	10	mV
$\text{OUT}_C$ Output Leak Current	$I_{OHC}$	$V_{OHC}=13.5\text{V}$	-	0	1	$\mu\text{A}$
$\text{OUT}_C$ Output Saturation Voltage	$V_{OLC}$	$I_{\text{OUT}}=4\text{mA}$ , $V_{SC}=5\text{V}$	-	0.10	0.40	V
$\text{OUT}_C$ Output Sink Current	$I_{\text{OUTC}}$	$V_{OLC}=1.0\text{V}$ , $V_{SC}=5\text{V}$	6	20	-	mA
$\overline{\text{RESET}}$ Guarantee Minimum Supply Voltage	$V_L^+$	$V_{OLR}=0.4\text{V}$ , $I_{\overline{\text{RESET}}}=200\mu\text{A}$	-	0.8	1.2	V

### ● AC CHARACTERISTICS

( $V^+=5.0\text{V}$ ,  $V_{SB}=5.0\text{V}$ ,  $V_{SC}=0\text{V}$ ,  $C_T=0.01\mu\text{F}$ ,  $T_a=25^\circ\text{C}$ )

ITEM	SYMBOL	CONDITION	MIN.	TYP.	MAX.	UNIT
$V_{SA}$ Input Pulse Width	$t_{PIA}$		-	3.0	-	$\mu\text{s}$
$V_{SB}$ Input Pulse Width	$t_{PIB}$		-	1.5	-	$\mu\text{s}$
$\overline{\text{RESET}}$ Output Pulse Width	$t_{PO}$	$V_{SB}=V^+$	-	1.5	-	ms
$\overline{\text{RESET}}$ Rise Time	$t_r$	$V_{SB}=V^+$ , $R_L=2.2\text{k}\Omega$ , $C_L=100\text{pF}$	-	1.0	-	$\mu\text{s}$
$\overline{\text{RESET}}$ Fall Time	$t_f$	$V_{SB}=V^+$ , $R_L=2.2\text{k}\Omega$ , $C_L=100\text{pF}$	-	0.1	-	$\mu\text{s}$
Output Delay Time	$t_{PD}$	$V_{SB}$ fall time	-	2	-	$\mu\text{s}$
Output Delay Time	$t_{PHL}$	$V_{SC}$ rise time, $R_L=2.2\text{k}\Omega$ , $C_L=100\text{pF}$	-	0.5	-	$\mu\text{s}$
Output Delay Time	$t_{PLH}$	$V_{SC}$ fall time, $R_L=2.2\text{k}\Omega$ , $C_L=100\text{pF}$	-	1.0	-	$\mu\text{s}$

## ■ TERMINAL FUNCTION

PIN NO.	SYMBOL	FUNCTION	INSIDE EQUIVALENT CIRCUIT
1	$C_T$	Pin Connection to Capacitor, Set the reset holding time.	
2	$V_{sc}$	Comparator Input	
3	$OUT_C$	Open Collector Output of Comparator C.	

# NJM2103

## ■ TERMINAL FUNCTION

PIN NO.	SYMBOL	FUNCTION	INSIDE EQUIVALENT CIRCUIT
4	GND	Ground	
5	V <sup>+</sup>	Operating Voltage	
6	V <sub>SB</sub> / $\overline{\text{RESIN}}$	Comparator B Input	
7	V <sub>SA</sub>	Comparator A Input	
8	$\overline{\text{RESET}}$	Reset Output Internalizing pull up resistor	

## APPLICATION CIRCUIT

### 1) 5V Supply Voltage Monitor

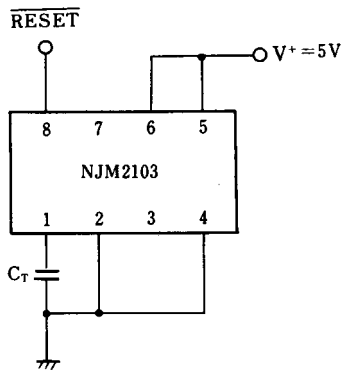

### 2) Monitoring of Optional Supply Voltage ( $V^+ \leq 13.5V$ )

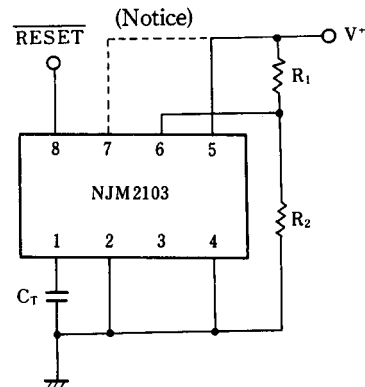

$$\text{Detecting Voltage} \doteq \left(1 + \frac{R_1}{R_2}\right) \times V_{SB}$$

(Notice)

If it were that  $V^+$  indicates under 4.50V, Connect 7 pin to  $V^+$

### 3) Monitoring of Optional Supply Voltage ( $V^+ > 13.5V$ )

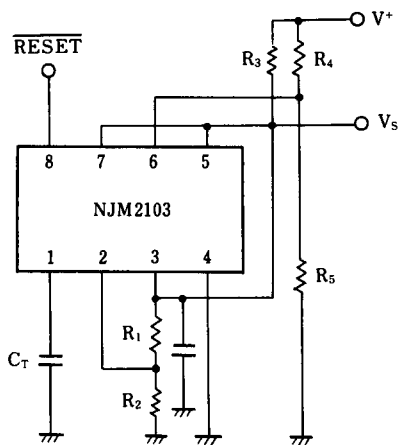

$$\text{Detecting Voltage} \doteq \left(1 + \frac{R_4}{R_5}\right) \times V_{SB}$$

$$\text{Constant Voltage Output } V_S \doteq \left(1 + \frac{R_1}{R_2}\right) \times V_{SC}$$

$$\overline{\text{RESET}} \text{ Output} \doteq \begin{cases} V_S \text{ (High Level)} \\ OV \text{ (Low Level)} \end{cases}$$

### 4) Compulsory Reset

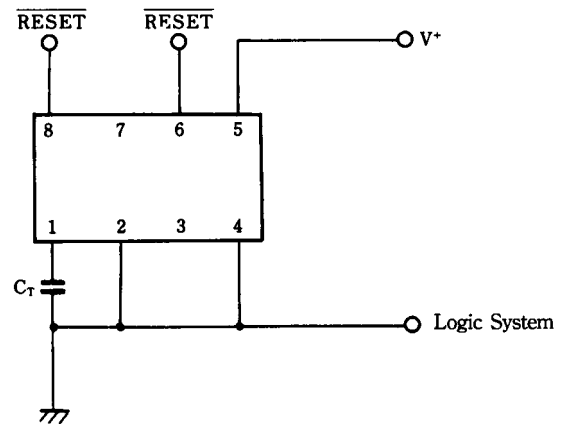

Input Reset signal TTL level to  $V_{SB}$  - terminal

# NJM2103

5) 5V,  $V_{CC} < 12V$  Supply Voltage Monitor

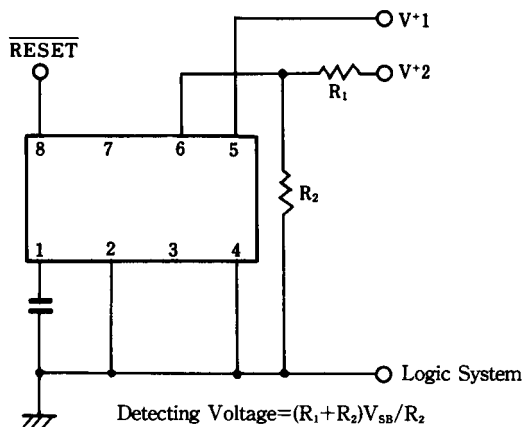

6) Non-Inverting Reset

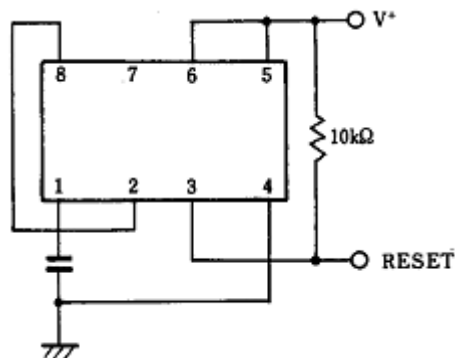

## ■ TYPICAL CHARACTERISTICS

Operating Current 1 vs. Operating Voltage

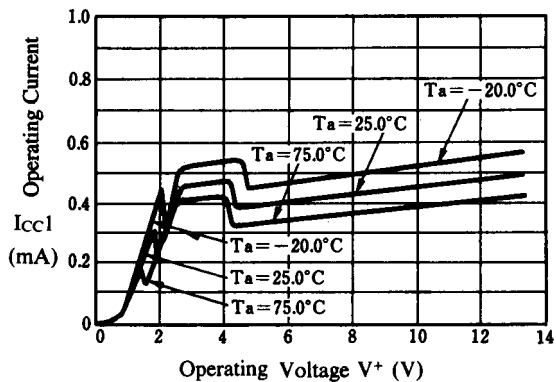

Operating Current 2 vs. Operating Voltage

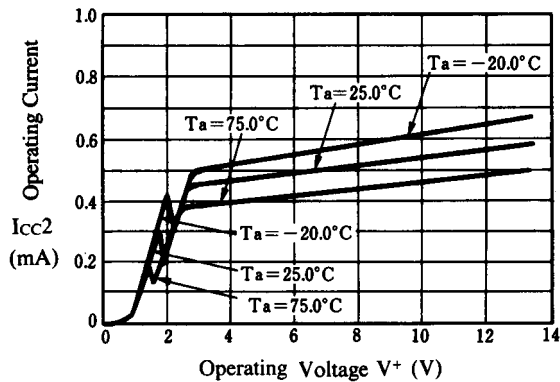

Output Voltage vs. Operating Voltage

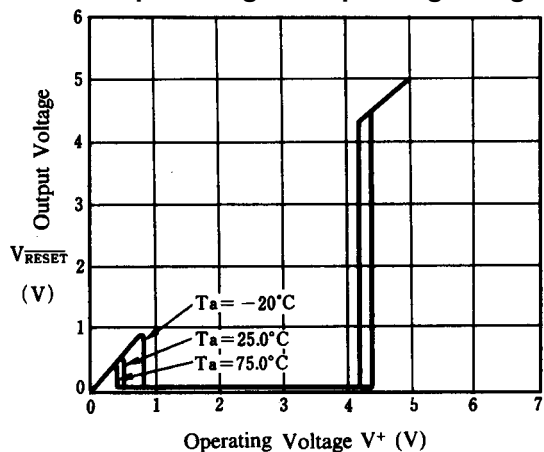

Detect Voltage ( $V_{SA}$ ) vs. Temperature

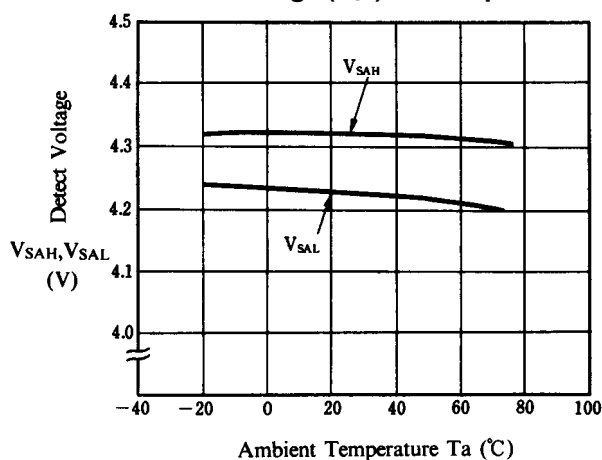

## ■ TYPICAL CHARACTERISTICS

Detect Voltage ( $V_{SA}$ ) vs. Temperature

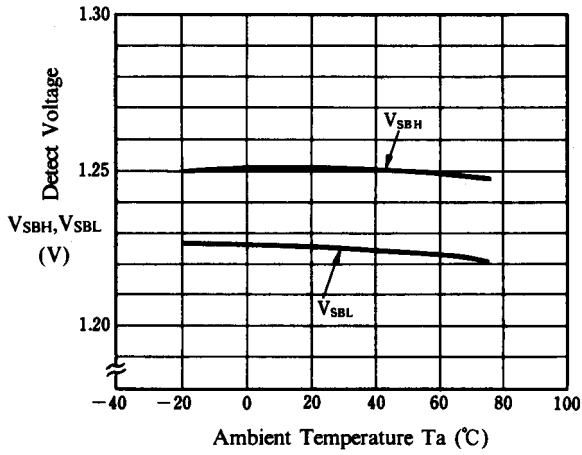

Detect Voltage ( $V_{SC}$ ) vs. Temperature

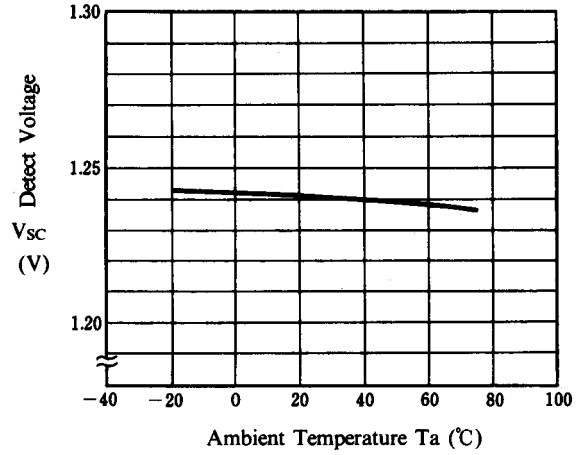

Output Voltage vs. Output Current

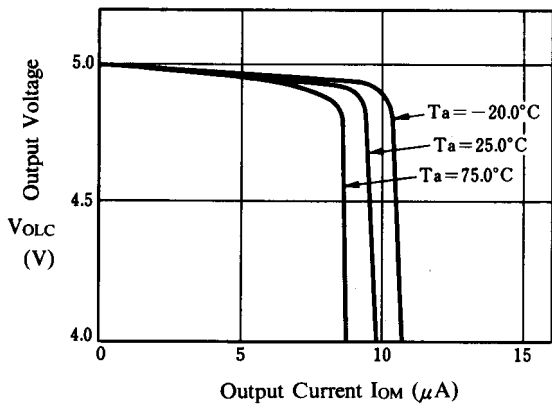

Output Voltage vs. Output Current

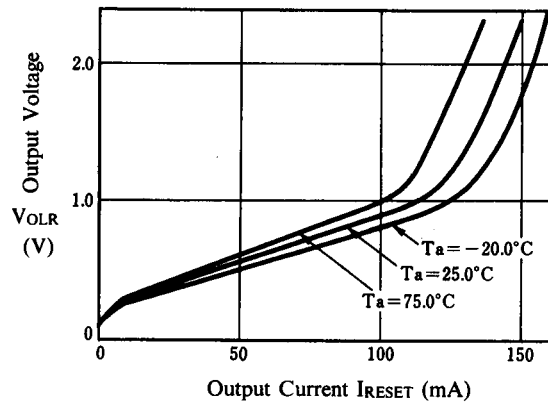

Output Voltage ( $OUT_C$ ) vs. Output Current ( $I_{OUTC}$ )

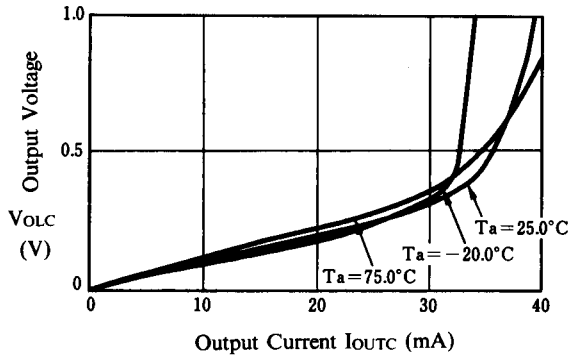

Detect Voltage ( $V_{SB}$ ,  $V_{SC}$ ) vs. Supply Voltage

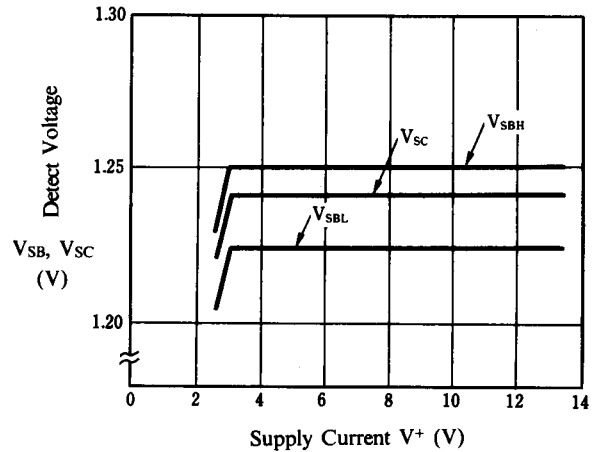



## ■ TYPICAL CHARACTERISTICS

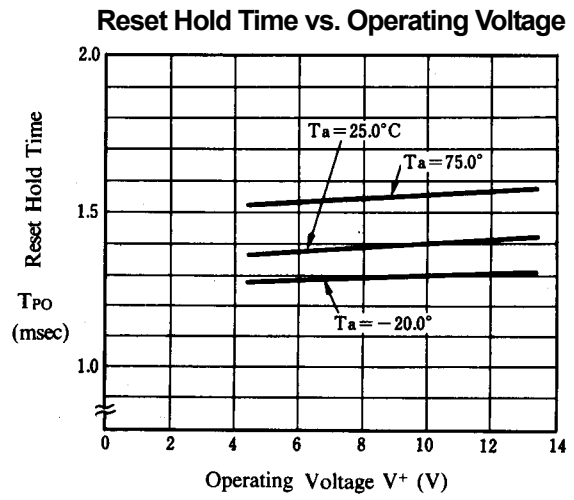
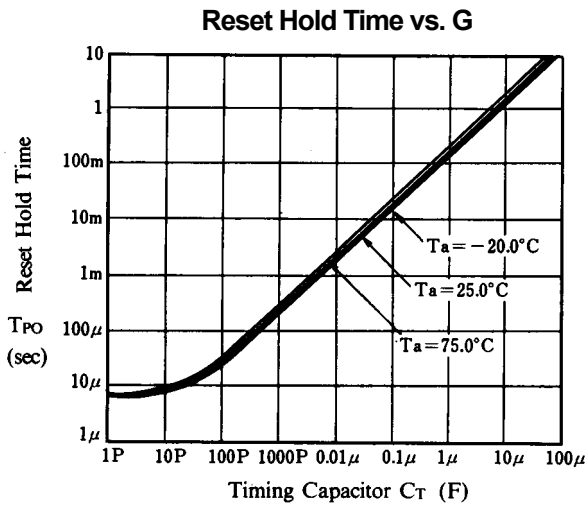

**[CAUTION]**

The specifications on this databook are only given for information, without any guarantee as regards either mistakes or omissions. The application circuits in this databook are described only to show representative usages of the product and not intended for the guarantee or permission of any right including the industrial rights.

## X-ON Electronics

Largest Supplier of Electrical and Electronic Components

*Click to view similar products for [Supervisory Circuits](#) category:*

*Click to view products by [Nisshinbo](#) manufacturer:*

Other Similar products are found below :

[CAT1161LI-25-G](#) [CAT853STBI-T3](#) [CAT1026LI-30-G](#) [CAT1320LI-25-G](#) [TC54VN2402EMB713](#) [MCP1316T-44NE/OT](#) [MCP1316MT-45GE/OT](#) [MCP1316MT-23LI/OT](#) [MAX8997EWW+](#) [MAX6725AKASYD3-LF-T](#) [DS1232L](#) [NCV302HSN45T1G](#) [PT7M6130NLTA3EX](#) [PT7M7811STBEX-2017](#) [S-1000N28-I4T1U](#) [CAT1161LI-28-G](#) [MCP1321T-29AE/OT](#) [MCP1319MT-47QE/OT](#) [S-1000N23-I4T1U](#) [S-1000N19-I4T1U](#) [CAT824UTDI-GT3](#) [TC54VC2502ECB713](#) [PT7M6133NLTA3EX](#) [PT7M6127NLTA3EX](#) [VDA2510NTA](#) [AP0809ES3-r](#) [HG811RM4/TR](#) [MD7030C](#) [MD7033C](#) [MD7019](#) [MD7020](#) [MD7021](#) [MD7023](#) [MD7024](#) [MD7027](#) [MD7030](#) [MD7033](#) [MD7035](#) [MD7036](#) [MD7039](#) [MD7040](#) [MD7044](#) [MD7050](#) [MD7015](#) [MD7022](#) [MD7028](#) [MD7031](#) [MD7042](#) [MD7043](#) [MD7047](#)