

PWM DC/DC CONVERTER IC

■GENERAL DESCRIPTION

The **NJM2374A** is a PWM DC/DC converter IC.

It features fixed frequency type PWM control for better noise handling and to avoid intermittent oscillation observed in a simplified controller.

It is suitable for Step-Up, Step-Down and Inverting applications for EMI sensitive application.

■FEATURES

- Operating Voltage (2.5V* to 40V)
- NJM2374AE Operating Voltage (2.5V* to 48V)
- Wide Oscillator Frequency (100Hz to 100kHz)
- Internal High Power Transistor 1.5A (max.)
- Internal Over Current Limit Circuit
- PWM form Switching Power Supply Control
- Bipolar Technology
- Package Outline DIP8, DMP8, SOP8 JEDEC 150mil SSOP14

*Ta =25°C. At low temperature, the minimum voltage is 3.0V.

■PACKAGE OUTLINE

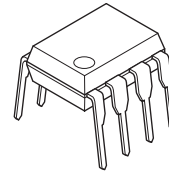

NJM2374AD
(DIP8)

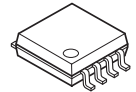

NJM2374AM
(DMP8)

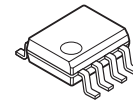

NJM2374AE
(SOP8)

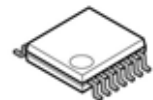

NJM2374AV
(SSOP14)

■PIN CONFIGURATION

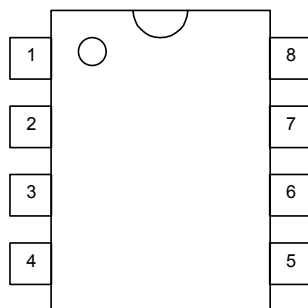

NJM2374AD
NJM2374AM
NJM2374AE

PIN FUNCTION

- | | |
|-------------------|--------------------|
| 1. C _S | 5. IN ⁺ |
| 2. E _S | 6. V ⁺ |
| 3. C _T | 7. S _I |
| 4. GND | 8. C _D |

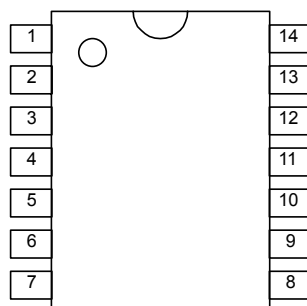

NJM2374AV

PIN FUNCTION

- | | |
|-------------------|--------------------|
| 1. C _S | 8. IN ⁺ |
| 2. NC | 9. NC |
| 3. E _S | 10. V ⁺ |
| 4. NC | 11. NC |
| 5. C _T | 12. S _I |
| 6. NC | 13. NC |
| 7. GND | 14. C _D |

■ABSOLUTE MAXIMUM RATINGS

(Ta=25°C)

PARAMETER	SYMBOL	RATINGS	UNIT
Maximum Supply Voltage	V ⁺	40 (NJM2374AE: 48V)	V
Output Switch Current	I _{SW}	1.5	A
Output Switch Voltage	V _{SW}	40 (NJM2374AE: 48V)	V
Comparator Input Voltage	V _{IR}	-0.3 ~ 40 (NJM2374AE: 48V)	V
Power Dissipation	P _D	(DIP8) 875 (DMP8) 750 (note1) (SOP8) 1,000 (note1) (SSOP14) 375	mW
Operating Temperature Range	Topr	-40 ~ +85	°C
Storage Temperature Range	Tstg	-50 ~ +150	°C

(note1) At on PC board.

In the case of Step-Down and Inverting Conversion with the internal power transistor, the Output Voltage must be set lower than 6V(-6V).

■POWER DISSIPATION vs. AMBIENT TEMPERATURE

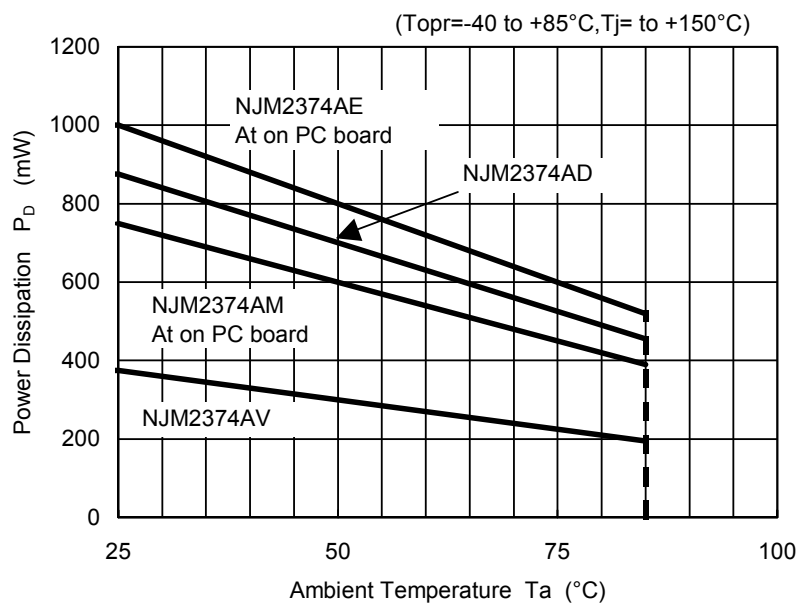

In the case of SSOP packaging, the power dissipation should carefully be considered when designing this parts.

NJM2374A

■ELECTRICAL CHARACTERISTICS

DC Characteristics ($V^+=5V$, $T_a=25^\circ C$)

PARAMETER	SYMBOL	TEST CONDITIONS	MIN.	TYP.	MAX.	UNIT
Operating Current 1	I_{CC1}	$C_T=1nF$, $S_I=V^+$, $IN^+ > V_{th}$, $E_S=GND$	–	2.8	4.0	mA
Operating Current 2 (NJM2374AE Only)	I_{CC2}	$V^+=48V$, $C_T=1nF$, $S_I=V^+$, $IN^+ > V_{th}$, $E_S=GND$	–	3.4	4.5	mA
Charge Current	I_{chg}		12	20	30	μA
Discharge Current	I_{dis}		110	180	300	μA
Voltage Swing	V_{OSC}		–	0.5	–	V_{P-P}
Discharge to Charge Current Ratio	I_{ratio}	$S_I=V^+$	–	9	–	–
Peak Current Sense Voltage	V_{ipk}	$I_{chg}=I_{dis}$	250	300	350	mV
Saturation Voltage 1	V_{sat1}	Darlington Connection ($C_S=C_D$), $I_{SW}=0.7A$	–	1.0	1.3	V
Saturation Voltage 2	V_{sat2}	$I_{SW}=0.7A$, $I_c(\text{driver})=50mA$ (Forced $\beta \approx 14$)	–	0.5	0.7	V
Output Transistor Bias Resistance	R_{bias}		–	160	–	Ω
DC Voltage Gain	h_{FE}	$I_{SW}=0.7A$, $V_{CE}=5.0V$	35	120	–	–
Collector Off-State Current	$I_{C(off)}$	$V_{CE}=40V$ (NJM2374AE: $V_{CE}=48V$)	–	10	–	nA
Threshold Voltage	V_{th}		1.225	1.250	1.275	V
Input Bias Current	I_B	$IN^+=0V$	–	40	400	nA

(note) Output switch tests are performed under pulsed conditions to minimize power dissipation.

■TIMING CHART

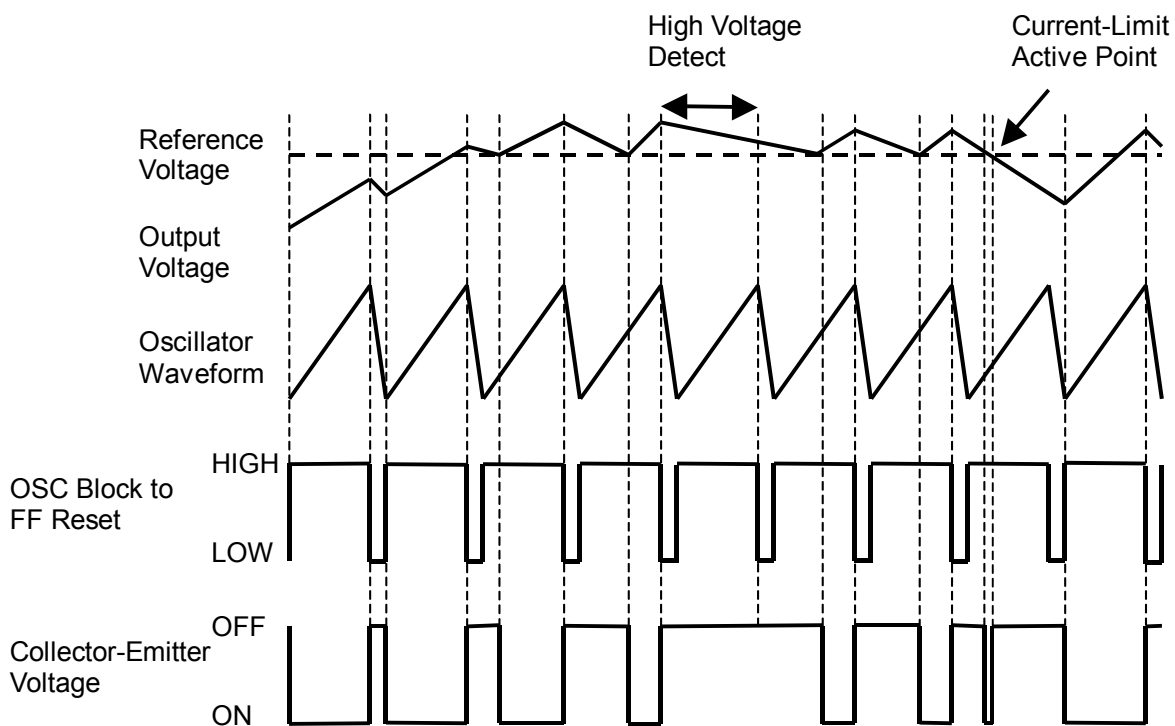

■ TYPICAL CHARACTERISTICS

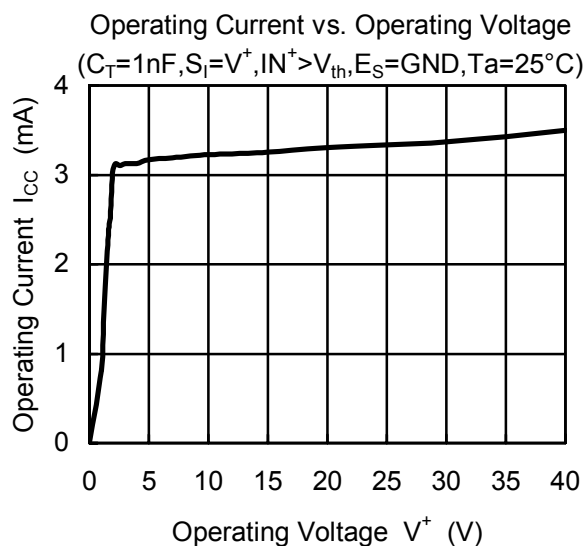
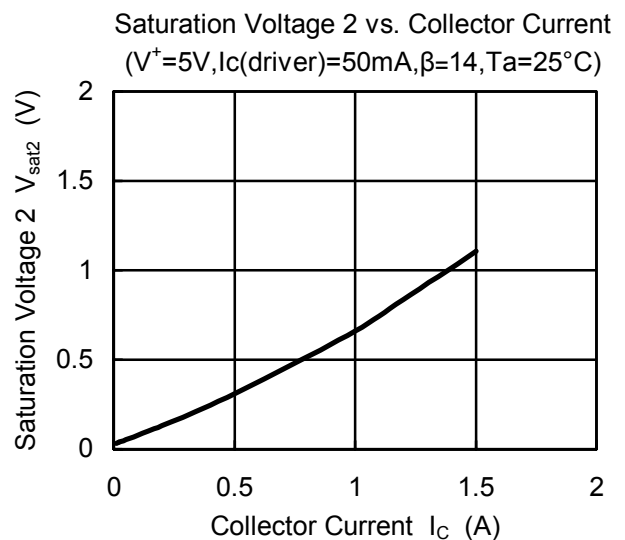
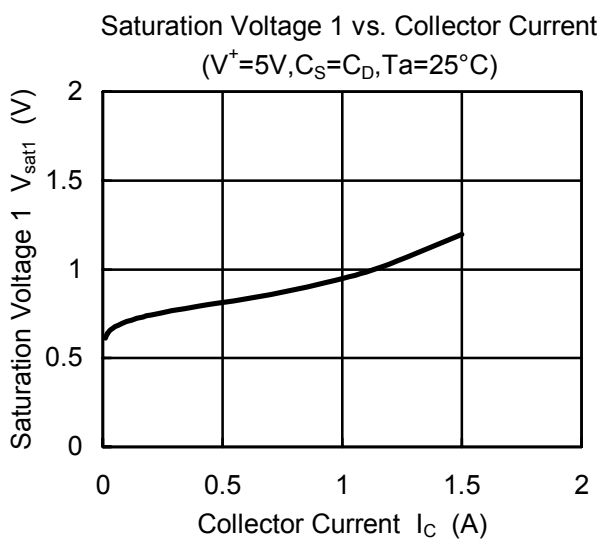
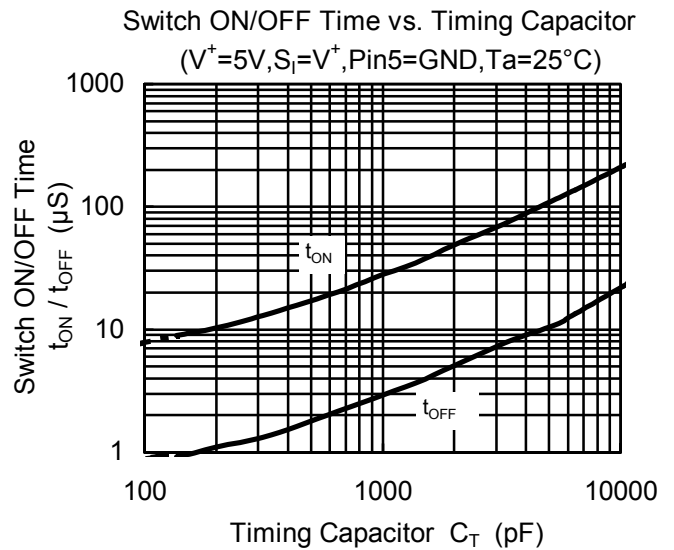
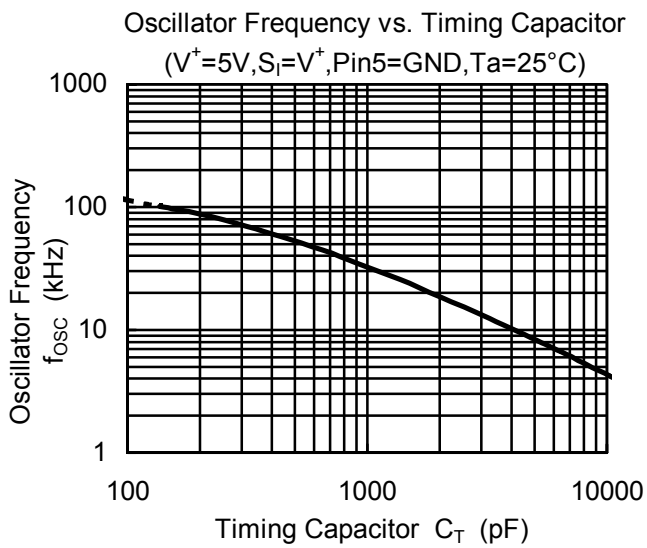

■ TYPICAL CHARACTERISTICS

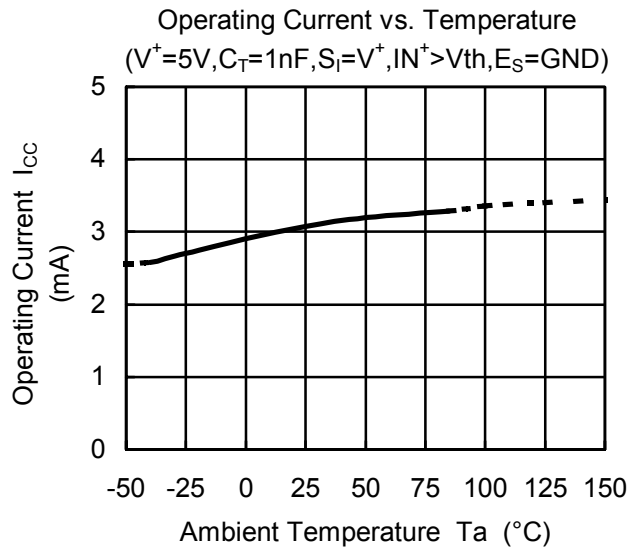
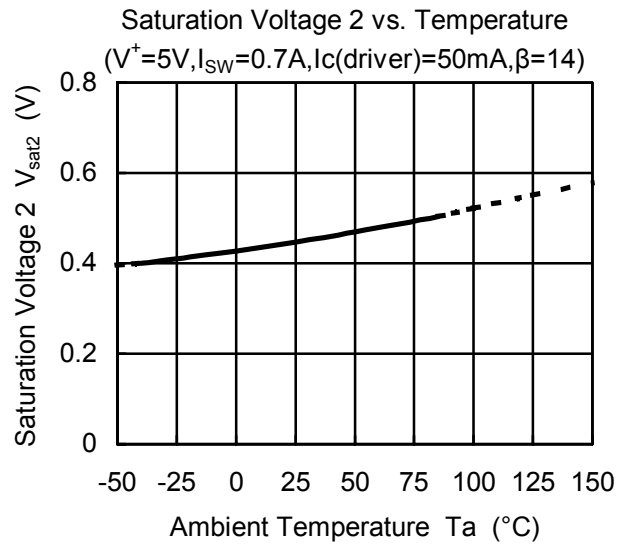
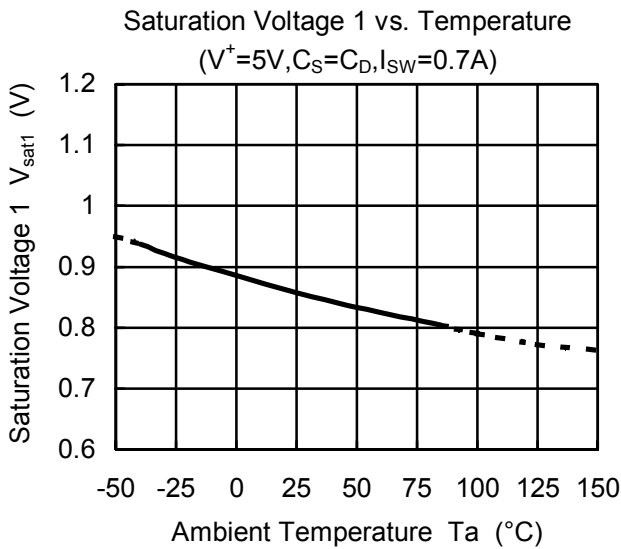
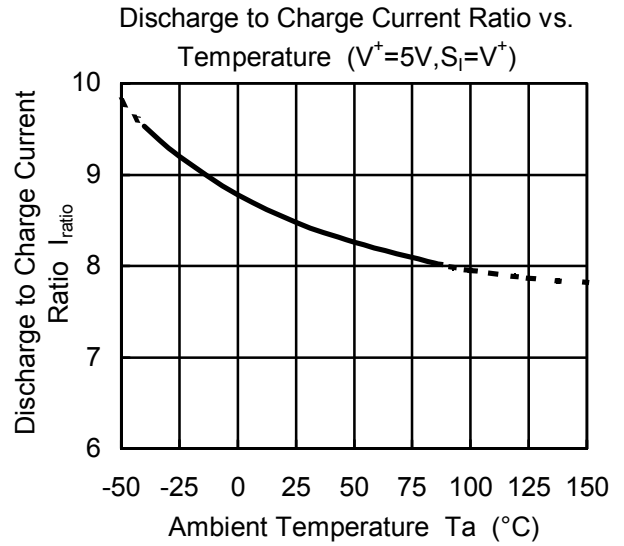
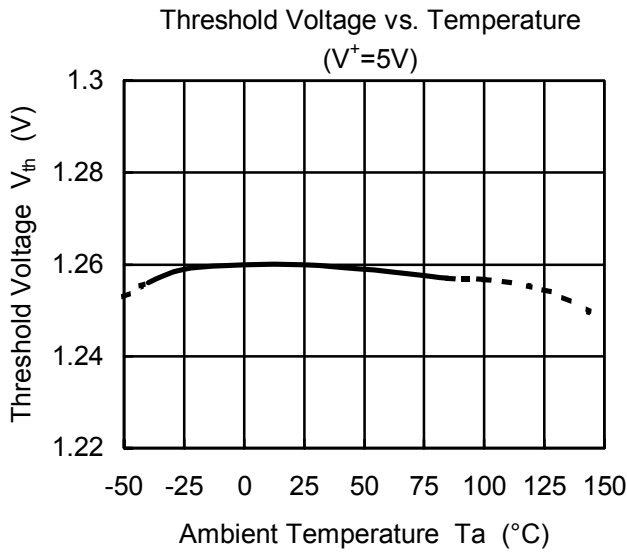

■ TYPICAL APPLICATIONS

Step-Down Converter

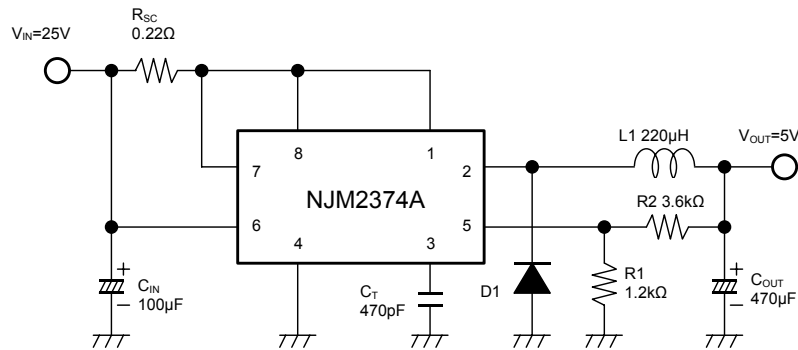

In the case of Step-Down Conversion with the internal power transistor, the Output Voltage must be set lower than 6V.

Step-Up Converter

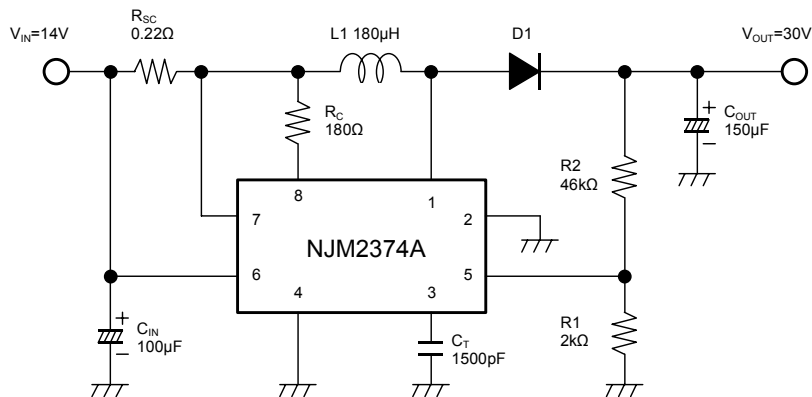

Inverting Converter

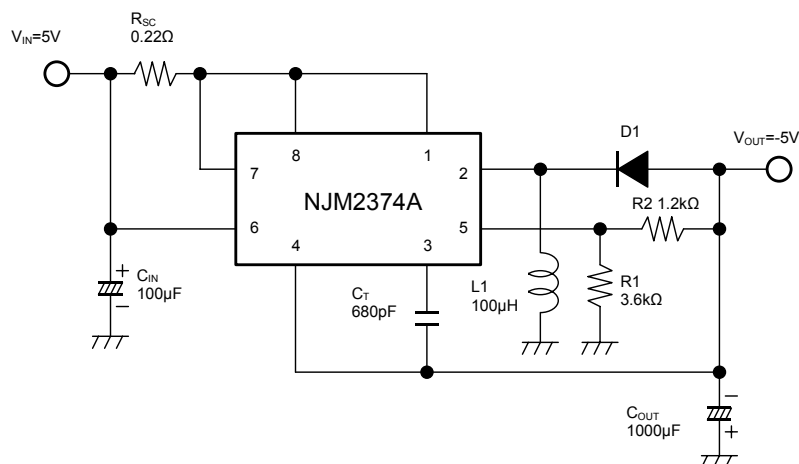

In the case of Inverting Conversion with the internal power transistor, the Output Voltage must be set lower than -6V.

D1 use to schottky diode.

In the case of SSOP packaging, the power dissipation should carefully be considered when designing this parts.

NJM2374A

Step-Down Converter (High Current)

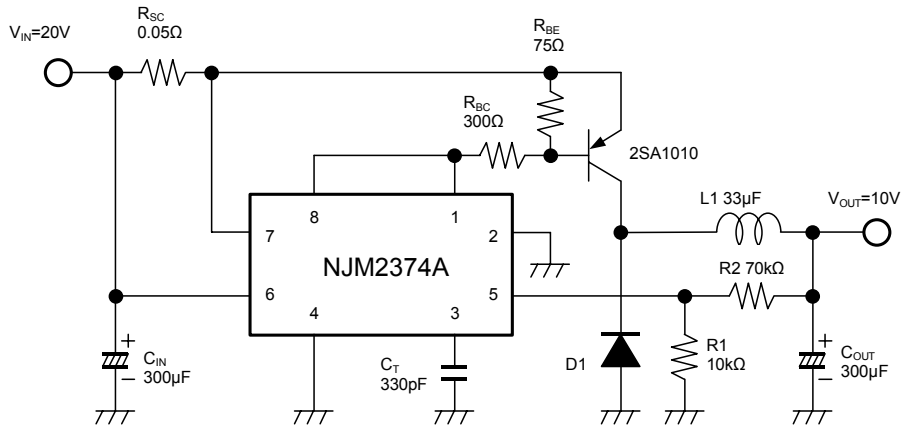

Step-Up Converter (High Current)

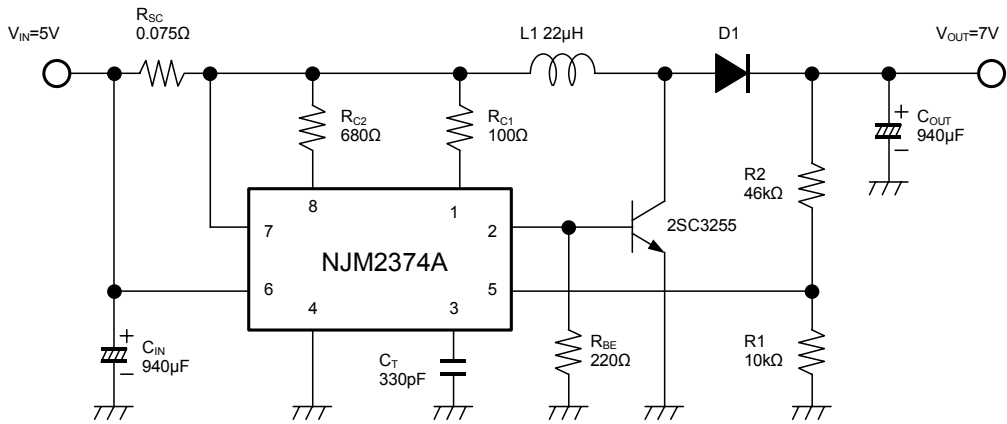

D1 use to schottky diode.

[CAUTION]
 The specifications on this databook are only given for information, without any guarantee as regards either mistakes or omissions. The application circuits in this databook are described only to show representative usages of the product and not intended for the guarantee or permission of any right including the industrial rights.

X-ON Electronics

Largest Supplier of Electrical and Electronic Components

Click to view similar products for [Switching Voltage Regulators](#) category:

Click to view products by [Nisshinbo](#) manufacturer:

Other Similar products are found below :

[FAN53610AUC33X](#) [FAN53611AUC123X](#) [FAN48610BUC33X](#) [FAN48610BUC45X](#) [FAN48617UC50X](#) [R3](#) [430464BB](#) [KE177614](#)
[MAX809TTR](#) [NCV891234MW50R2G](#) [NCP81103MNTXG](#) [NCP81203PMNTXG](#) [NCP81208MNTXG](#) [NCP81109GMNTXG](#)
[SCY1751FCCT1G](#) [NCP81109JMNTXG](#) [AP3409ADNTR-G1](#) [NCP81241MNTXG](#) [LTM8064IY](#) [LT8315EFE#TRPBF](#) [NCV1077CSTBT3G](#)
[XCL207A123CR-G](#) [MPM54304GMN-0002](#) [MPM54304GMN-0003](#) [XDPE132G5CG000XUMA1](#) [MP8757GL-P](#) [MIC23356YFT-TR](#)
[LD8116CGL](#) [HG2269M/TR](#) [OB2269](#) [XD3526](#) [U6215A](#) [U6215B](#) [U6620S](#) [LTC3803ES6#TR](#) [LTC3803ES6#TRM](#) [LTC3412IFE](#) [LT1425IS](#)
[MAX25203BATJA/VY+](#) [MAX77874CEWM+](#) [XC9236D08CER-G](#) [ISL95338IRTZ](#) [MP3416GJ-P](#) [BD9S201NUX-CE2](#) [MP5461GC-Z](#)
[MPQ4415AGQB-Z](#) [MPQ4590GS-Z](#) [MCP1603-330IMC](#) [MCP1642B-18IMC](#) [MCP1642D-ADJIMC](#)