

75Ω Driver with Filter and Y/C MIX

■ GENERAL DESCRIPTION

NJM2570A is a video amplifier included LPF in Y and C system. Adjustable LPF characteristic with external resistor and output with 75ohm driver optimize the TV monitor system.

Also, it can discriminated the aspect ratio of TV by internal DC interface for S terminal.

NJM2570A includes power save circuit to suitable for portable video application.

■ PACKAGE OUTLINE



NJM2570AV

■ FEATURES

- Operating Voltage 4.5 to 5.5V
- Input Y and C 0.5Vpp
- Internal LPF
 - 0dBtyp. at 4MHz (at IREF=33kΩ)
 - 35dBtyp. at 10MHz (at IREF=33kΩ)
 - 0dBtyp. at 6MHz (at IREF=22kΩ)
 - 40dBtyp. at 16MHz (at IREF=22kΩ)
- Internal DC Interface for aspect ratio discrimination
- Bipolar technology
- Package Outline SSOP16

■ PIN CONFIGURATION

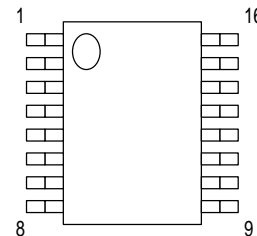

1. Cin
2. GND
3. SDCin
4. SDCout
5. Cout
6. Vout
7. Vsag
8. GND2
9. V+2
10. Ysag
11. Yout
12. VREF
13. POWERSAVE
14. Yin
15. V+1
16. IREF

■ BLOCK DIAGRAM

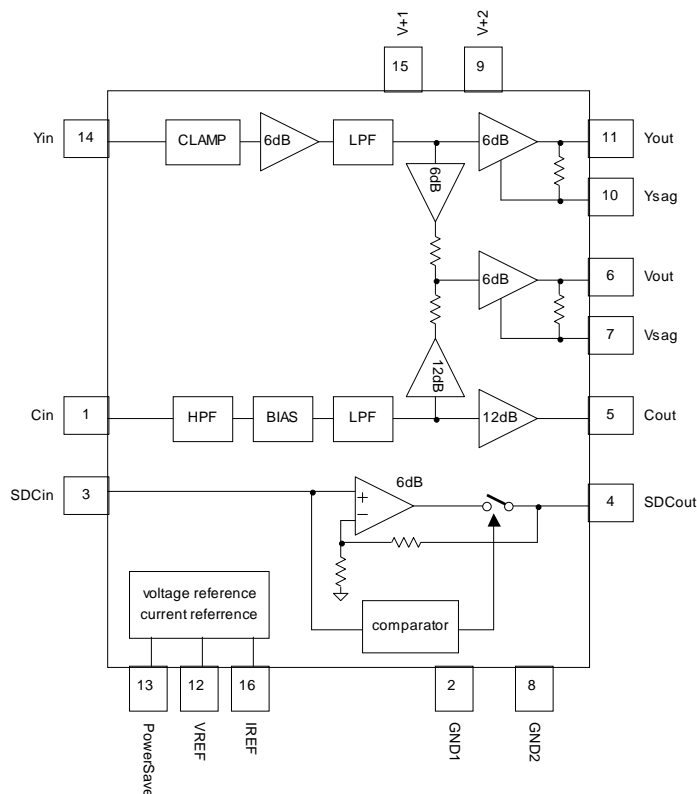

NJM2570A

■ ABSOLUTE MAXIMUM RATINGS(Ta=25°C)

PARAMETER	SYMBOL	RATINGS	UNIT
Supply Voltage	V ⁺	7.0	V
Power Dissipation	P _D	300	mW
Operating Temperature Range	T _{opr}	-40 to +85	°C
Storage Temperature Range	T _{stg}	-40 to +125	°C

■ RECOMMENDED OPEARATING CONDITION(Ta=25°C)

PARAMETER	SYMBOL	RATINGS	MIN.	TYP.	MAX.	UNIT
Operating Voltage 1	Vopr1	V ⁺¹	4.5	5.0	5.5	V
Operating Voltage 2	Vopr2	V ⁺²	4.5	5.0	5.5	V

■ ELECTRICAL CHARACTERISTICS ($V^+1=V^+2=5.0V$, Powersave=1.8V, IREF=22k Ω , SDCin=open, SDCout=100k Ω , RL=150 Ω , Input=ACgnd(75 Ω to GND), Ta=25°C at non-designation)

PARAMETER	SYMBOL	TEST CONDITION	MIN.	TYP.	MAX.	UNIT
Operating Circuit 1	I _{CC1}	V ⁺ 1=5.0V, No signal	-	10	18	mA
Operating Circuit 2	I _{CC2}	V ⁺ 2=5.0V, No signal	-	15	25	mA
Operating Circuit 1 at Power Save	I _{save1}	V ⁺ 1=5.0V, Power Save Mode	-	50	120	μ A
Operating Circuit 2 at Power Save	I _{save2}	V ⁺ 2=5.0V, Power Save Mode	-	0	120	μ A
Voltage Gain 1(Y Signal)	G _{vy}	Yin=100kHz, 0.5Vpp Input Sign signal	12.0	12.4	12.9	dB
Voltage Gain Difference 1 (Y Signal)	Δ G _{vyv}	Yin=100kHz, 0.5Vpp Input Sign signal, Measure the G _{vv3} =V _{out} /Yin. Δ G _{vyv} =G _{vv3} -G _{vy}	-0.5	0	+0.5	dB
Voltage Gain 1(C Signal)	G _{vc}	Cin=4.43MHz, 0.15Vpp Input Sign signal	12.5	13.5	14.5	dB
Voltage Gain Difference 2 (C Signal)	Δ G _{vcv}	Cin=4.43MHz, 0.15Vpp Input Sign signal, Measure the G _{vv2} =V _{out} /Cin. Δ G _{vcv} =G _{vv2} -G _{vc}	-0.5	0	+0.5	dB
Voltage Gain 1(V Signal)	G _{vv}	Yin=100kHz, 0.5Vpp Input Sign signal	12.0	12.4	12.9	dB
Frequency Characteristics (Y Signal)	G _{fy1-1}	Yin=4MHz/100kHz, 0.5Vpp, Input Sine signal IREF=33k Ω	-3.0	0	1.0	dB
	G _{fy1-2}	Yin=10MHz/100kHz, 0.5Vpp, Input Sign signal IREF=33k Ω	-	-35	-30	
	G _{fy2-1}	Yin=6MHz/100kHz, 0.5Vpp, Input Sine signal IREF=22k Ω	-3.0	0	2.0	
	G _{fy2-2}	Yin=16MHz/100kHz, 0.5Vpp Input Sine signal, IREF=22k Ω	-	-40	-30	
Frequency Characteristics (C Signal)	G _{fc1-1}	Cin=4.43MHz-500kHz, 0.15Vpp Input Sine signal, IREF=33k Ω	-1.0	1.0	3.0	dB
	G _{fc1-2}	Cin=4.43MHz+500kHz, 0.15Vpp Input Sine signal, IREF=33k Ω	-5.0	-2.0	1.0	
	G _{fc1-3}	Cin=10MHz/4.43MHz, 0.15Vpp Input Sign signal, IREF=33k Ω	-	-35	-30	
	G _{fc2-1}	Cin=4.43MHz-500kHz, 0.15Vpp Input Sine signal, IREF=22k Ω	-1.0	0	1.0	
	G _{fc2-2}	Cin=4.43MHz+500kHz, 0.15Vpp Input Sine signal, IREF=22k Ω	-1.0	0	1.0	
	G _{fc2-3}	Cin=16MHz/4.43MHz, 0.15Vpp Input Sign Singal, IREF=22k Ω	-	-40	-30	
	G _{fc3}	Cin=1MHz/4.43MHz, 0.15Vpp Input Sign Signal, IREF=22k Ω	-	-1.5	-	
Y/C Delay1	T _{dYC1}	IREF=22k Ω	-	0	-	ns
Y/C Delay2	T _{dYC2}	IREF=33k Ω	-	0	-	ns
Y Group Delay1	T _{dY1}	IREF=22k Ω , 4.43MHz, Sign Signal	-	100	-	ns
Y Group Delay2	T _{dY2}	IREF=33k Ω , 4.43MHz, Sign Signal	-	155	-	ns
C Group Delay1	T _{dC1}	IREF=22k Ω , 4.43MHz, Sign Signal	-	100	-	ns
C Group Delay2	T _{dC2}	IREF=33k Ω , 4.43MHz, Sign Signal	-	155	-	ns

NJM2570A

■ **ELECTRICAL CHARACTERISTICS** ($V^+1=V^+2=5.0V$, Powersave=1.8V, IREF=22k Ω , SDCin=open, SDCout=100k Ω , $R_L=150\Omega$, Input=ACgnd(75 Ω to GND), Ta=25°C at non-designation)

PARAMETER	SYMBOL	TEST CONDITION	MIN.	TYP.	MAX.	UNIT
Maximum Output Voltage Swing 1(Y Signal)	Voym	$V^+1=V^+2=4.5V$, Yin=100kHz, Sine Signal, THD=1%, $R_L=75\Omega$	1.2	1.5	-	Vp-p
Maximum Output Voltage Swing 1(C Signal)	Vocm	$V^+1=V^+2=4.5V$, Cin=4.43MHz, Sine Signal, THD=1%, $R_L=75\Omega$	1.05	1.85	-	Vp-p
Maximum Output Voltage Swing 1(V Signal)	Vovm	$V^+1=V^+2=4.5V$, Yin=100kHz, Sine Signal, THD=1%, $R_L=75\Omega$	1.2	1.4	-	Vp-p
Differential Gain(Y)	DGy	Yin=0.5Vpp, 10Step video signal, measure the Yout.	-	0.6	-	%
Differential Phase(Y)	DPy	Yin=0.5Vpp, 10Step video signal, measure the Yout.	-	0.6	-	deg
Differential Gain(V)	DGv	Yin=0.5Vpp, Cin=0.15V, 10Step video signal, measure the Vout.	-	0.2	-	%
Differential Phase(V)	DPv	Yin=0.5Vpp, Cin=0.15V, 10Step video signal, measure the Yout.	-	0.2	-	deg
SW Change Voltage High Level for Power Save	VcH	Active	1.8	-	V ⁺	V
SW Change Voltage High Level for Power Save	VcL	Non-active	0	-	0.3	
Crosstalk 1(Yin to Cout)	CTyc	Yin to Cout=20log(Cout/Yout) Yin=4.43MHz, 0.5Vpp Sine Signal, Cin=AC GND	-	-50	-40	dB
Crosstalk 2(Cin to Yout)	CTcy	Cin to Yout=20log(Yout/Cout) Cin=4.43MHz, 0.15Vpp Sine Signal, Yin=AC GND	-	-50	-40	dB
S/N1(Y Signal)	SNy	Yin=50% White Video Signal, $R_L=75\Omega$ at Yout Bandwidth 100kHz to 6MHz	-	60	-	dB
S/N2(C Signal)	SNc	Cin=100% Red Field Video Signal, $R_L=75\Omega$ at Cout Bandwidth 100Hz to 500kHz	-	60	-	dB
S/N3(C Signal)	SNc2	Cin=100% Red Field Video Signal, $R_L=75\Omega$ at Cout Bandwidth 100Hz to 500kHz PM Noise	-	64	-	dB
S/N4 (V Signal)	SNv	Yin=50% White Video Signal, $R_L=75\Omega$ at Vout Bandwidth 100kHz to 6MHz	-	57	-	dB
S/N5(C→V Signal)	SNv2	Cin=100% Red Field Video Signal, $R_L=75\Omega$ at Cout Bandwidth 100Hz to 6MHz AM Noise	-	68	-	dB
S/N6(C→V Signal)	SNcv	Cin=100% Red Field Video Signal, $R_L=75\Omega$ at Vout Bandwidth 100Hz to 6MHz PM Noise	-	64	-	dB
Total Harmonics Distortion (Y Signal)	THDy	$V^+1=V^+2=4.5V$, IREF=22k Ω , Yin=100kHz, 0.5Vpp sing signal	-	-	0.8	%
Total Harmonics Distortion (V Signal)	THDv	$V^+1=V^+2=4.5V$, IREF=22k Ω , Yin=100kHz, 0.5Vpp sign signal	-	-	0.8	%

■ ELECTRICAL CHARACTERISTICS ($V^{+1}=V^{+2}=5.0V$, Powersave=1.8V, IREF=22k Ω , SDCin=open, SDCout=100k Ω , $R_L=150\Omega$, Input=ACgnd(75 Ω to GND), Ta=25°C at non-designation)

PARAMETER	SYMBOL	TEST CONDITION	MIN.	TYP.	MAX.	UNIT
2nd. Distortion 1 (Y Signal)	Hy	Yin=1MHz,0.5Vpp, Sine Signal	-	-50	-	dB
2nd. Distortion 2 (C Signal)	Hc	Cin=4.43MHz,0.15Vpp, Sine Signal	-	-50	-	dB
2nd. Distortion 3 (V Signal)	Hv1	Yin=1MHz,0.5Vpp, Sine Signal	-	-47	-	dB
2 nd . Distortion 4 (C to V Signal)	Hv2	Yin=DC,Cin=4.43MHz, $V^{+1}=V^{+2}=4.7V$,Vout=1.275Vpp(Cout= 0.91Vpp in Vout)	-	-50	-	dB
SDC Voltage Gain	Gv SDC	SDCin=1.0V, $R_L=100k\Omega$	5.5	6.0	6.5	dB
SDC Maxim Output Voltage	Vom SDC	$R_L=100k\Omega$, $V^{+1}=V^{+2}=4.5V$ *1	3.6	-	-	V
Threshold Voltage for SDC Output Impedance	VthR SDC	Change Guarantee for SDC High Impedance	-	-	0.3	V
SDC Output Impedance	RSDC	SDCout at High Impedance	140	220	275	k Ω

*1 Reference to the TEST CIRCUIT.

■ CONTROL TERMINAL

PARAMETER	CONTROL	NOTES
Power Save	H	Power Save: OFF
	L	Power Save: ON
	OPEN	Power Save: ON

NJM2570A

TEST CIRCUIT

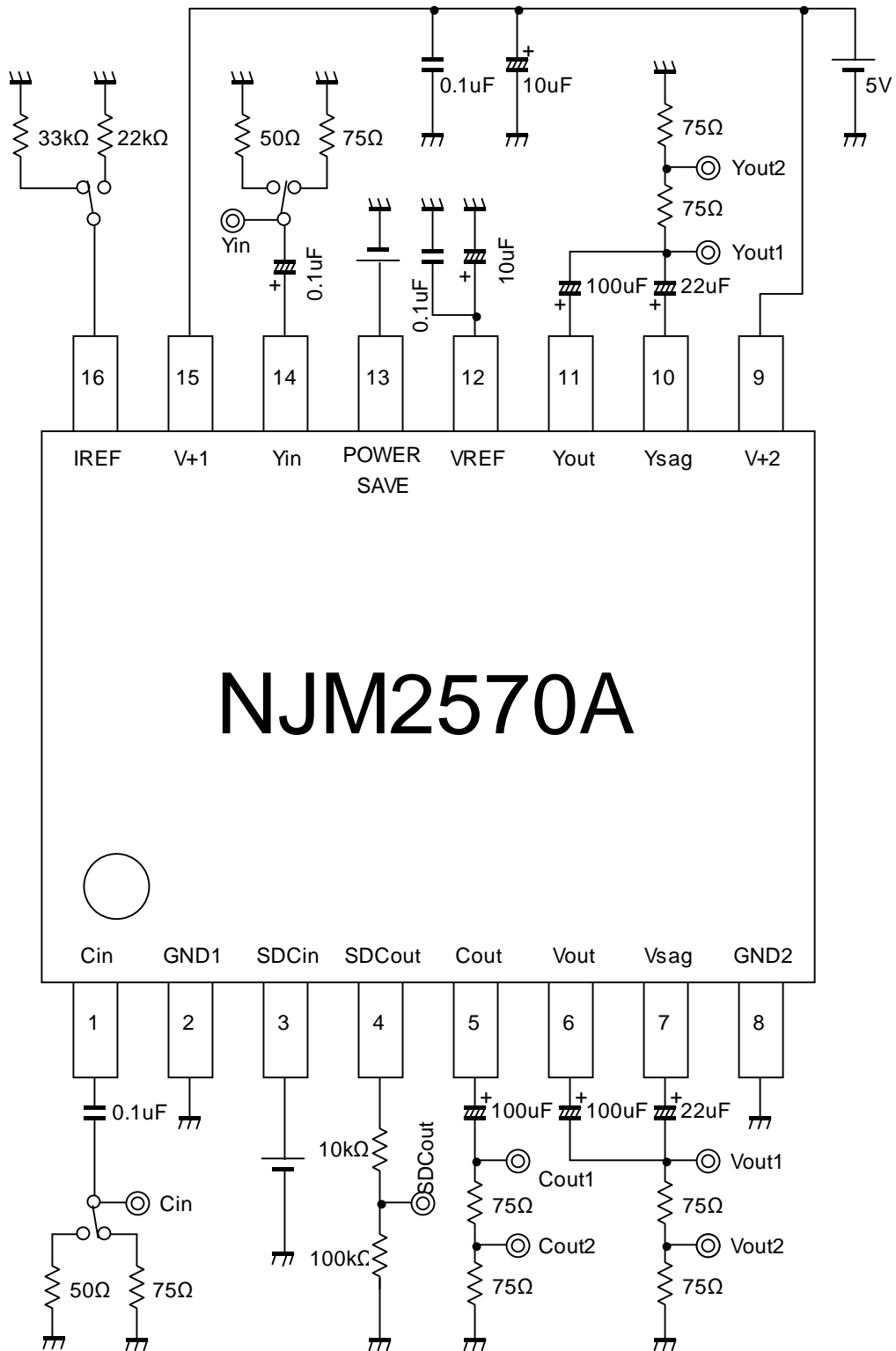

[CAUTION]

The specifications on this databook are only given for information, without any guarantee as regards either mistakes or omissions. The application circuits in this databook are described only to show representative

X-ON Electronics

Largest Supplier of Electrical and Electronic Components

Click to view similar products for [Video ICs category](#):

Click to view products by [Nisshinbo manufacturer](#):

Other Similar products are found below :

[M21328G-12](#) [TW2964-LA2-CR](#) [TW9903-FB](#) [TW9919-PE1-GR](#) [ADV8003KBCZ-7T](#) [PI3HDX511DZLEX](#) [M23428G-33](#)
[PI7VD9008ABHFDE](#) [ADV7186BBCZ-TL](#) [ADV7186BBCZ-T-RL](#) [ADV8003KBCZ-7C](#) [PI3VDP411LSAZBEX](#) [PI3VDP411LSTZBEX](#)
[M23145G-14](#) [PI3VDP411LSRZBEX](#) [PI3HDX511EZLSEX](#) [BH76912GU-E2](#) [CM5100-01CP](#) [TVP5160PNP](#) [TVP5151PBSR](#) [BA7603F-E2](#)
[MU82645DES S LM6B](#) [BH76106HFV-TR](#) [BH76206HFV-TR](#) [ADV7179WBCPZ](#) [ADV7611BSWZ-P-RL](#) [ADV7180KCP32Z](#)
[ADV7180WBCP32Z](#) [ADV7182WBCPZ](#) [ADV7280KCPZ](#) [ADV7280WBCPZ-M](#) [ADV7281WBCPZ-MA](#) [ADV7283WBCPZ](#) [ADV7283BCPZ](#)
[ADV7282WBCPZ-M](#) [ADV7280KCPZ-M](#) [ADV7280WBCPZ](#) [ADV7180KCP32Z-RL](#) [ADV7282AWBCPZ](#) [ADV7182AWBCPZ](#)
[AD723ARUZ](#) [ADV7611BSWZ](#) [ADV7181DWBCPZ-RL](#) [ADV7173KSTZ-REEL](#) [ADV7180WBST48Z-RL](#) [ADA4411-3ARQZ](#) [ADA4411-3ARQZ-R7](#) [ADA4417-3ARMZ](#) [ADA4417-3ARMZ-R7](#) [ADA4424-6ARUZ](#)