

## QUAD VIDEO DRIVER

### ■ GENERAL DESCRIPTION

The **NJM2577** is a quad video driver. The **NJM2577** includes LPF, 6dB amplifier and 75Ω Driver on all channels.

The **NJM2577** enable to control the Output Impedance. It is suitable for Video system for Europe.

### ■ PACKAGE OUTLINE

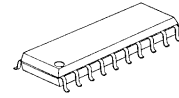

**NJM2577M**

### ■ FEATURES

- Operating Voltage            $\pm 5V$
- Internal 6dB Amplifier
- Internal 75Ω Driver Circuit
- Quad 5<sup>th</sup> order Butter worth Low Pass Filter
- Internal High Impedance output control switch
- 41dB Stop Band Rejection at 27MHz
- Bipolar Technology
- Package Outline               DMP20

### ■ FUNCTION BLOCK DIAGRAM

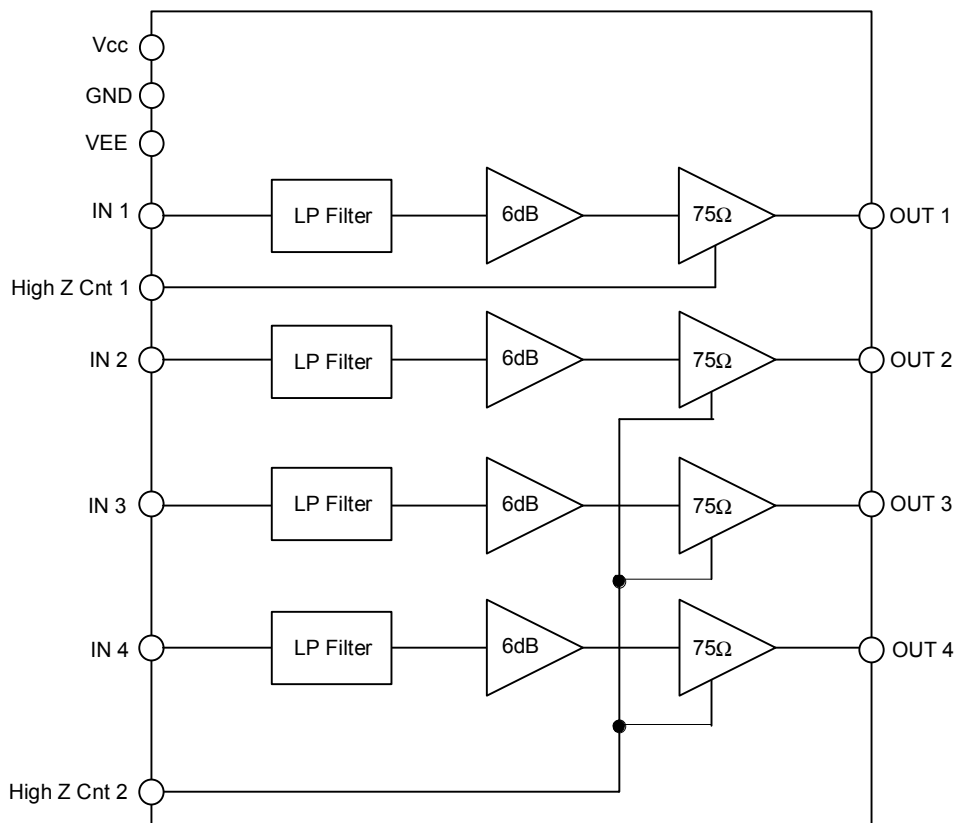



**■ ABSOLUTE MAXIMUM RATING (Ta=25°C)**

PARAMETER	SYMBOL	RATING	UNIT
Supply Voltage	V <sub>CC</sub> /V <sub>EE</sub>	±7.5	V
Power Dissipation	P <sub>D</sub>	450 (Note)	mW
Operating Temperature Range	T <sub>opr</sub>	-40 to +85	°C
Storage Temperature Range	T <sub>stg</sub>	-40 to +125	°C

(Note) At on a board of EIA/JEDEC specification. (11.43 x 76.2 x 1.6mm Two layers, FR-4)

**■ ELECTRICAL CHARACTERISTICS (Ta=25°C)**

PARAMETER	SYMBOL	TEST CONDITION	MIN.	TYP.	MAX.	UNIT
Operating Voltage	V <sub>CC</sub> /V <sub>EE</sub>		±4.5	±5.0	±5.5	V
Supply Current	I <sub>CC</sub>	No Signal, No Load	20	30	39	mA

**● VIDEO SYSTEM (Ta=25°C, V<sub>CC</sub>=5.0V, V<sub>EE</sub>=-5V, R<sub>L</sub>=150Ω unless otherwise specified.)**

PARAMETER	SYMBOL	TEST CONDITION	MIN.	TYP.	MAX.	UNIT
Gain	GV	V <sub>in</sub> =1.0Vp-p 100kHz	6.0	6.4	6.8	dB
Frequency Response Characteristics	FBW	V <sub>in</sub> =1.0Vp-p, 5MHz /100kHz	-1.0	0	1.0-	dB
Stop Band Rejection	Fsb	f=27MHz/100kHz, 1Vp-p	-35	-41	-	dB
-3dB Bandwidth	Fc		-	7.1	-	MHz
Gain matching level	Gm	Out2, Out3, Out4	-5	0	5	%
Total Harmonic Distortion	THD	f=1kHz, 1Vp-p input	-	0.1	-	%
Cross talk	CT	V <sub>in</sub> =4.43MHz, 1.0Vp-p	-	-60	-	dB
Differential Gain	DG	V <sub>in</sub> =1Vp-p, 10step Stairs-signal	-	0.4	-	%
Differential Phase	DP	V <sub>in</sub> =1Vp-p, 10step Stairs-signal	-	0.4	-	deg
Input Impedance	R <sub>in</sub>	All Channel	-	50	-	KΩ
Output Impedance	R <sub>o1</sub>	High Z Cont="0"	10	20	-	KΩ
Output Impedance	R <sub>o2</sub>	High Z Cont="1"	-	45	-	mΩ
Equivalent Output Capacitance	C <sub>o</sub>	High Z Cont="0"	-	3	-	pF
Group Delay	T <sub>pd</sub>	V <sub>in</sub> =1Vp-p, 100kHz	-	70	-	nS

**● SWITCH CONTROL ( Ta=25°C, V<sub>CC</sub>=5.0V, V<sub>EE</sub>=-5V, R<sub>L</sub>=150Ω unless otherwise specified.)**

PARAMETER	SYMBOL	TEST CONDITION	MIN	TYP	MAX	UNIT
High Z Control Logic-High level	V <sub>ihz</sub>		2.0	-	-	V
High Z Control Logic-Low level	V <sub>ilz</sub>		-	-	0.8	V

**● SWITCH CONTROL TABLE**

Control Signal	Outputs Impedance
0*	High Impedance
1	Through

\* : Default setting

# NJM2577

## ■ PIN DESCRIPTION

PIN No.	SYMBOL	INSIDE EQUIVALENT CIRCUIT	VOLTAGE
1 11 12 13	OUT1 OUT3 OUT4 OUT2		0V
3 6 9 17	IN2 IN3 IN4 IN1		0V
19 20	HighZCnt1 HighZCnt2		0V
2 7 15	Vcc1 Vcc Vcc2		+5V

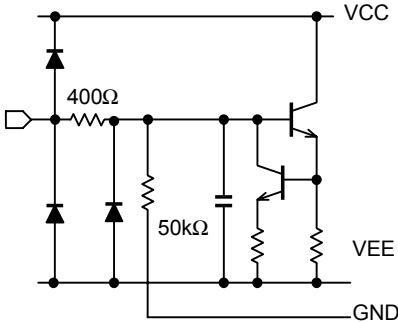
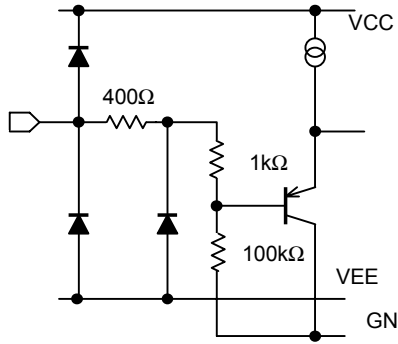
PIN No.	SYMBOL	INSIDE EQUIVALENT CIRCUIT	VOLTAGE
<p style="text-align: center;">5 10 16</p>	<p style="text-align: center;">GND1 GND2 GND</p>		<p style="text-align: center;">0V</p>
<p style="text-align: center;">4 8 14</p>	<p style="text-align: center;">VEE1 VEE VEE2</p>		<p style="text-align: center;">-5V</p>

# NJM2577

## TEST CIRCUIT

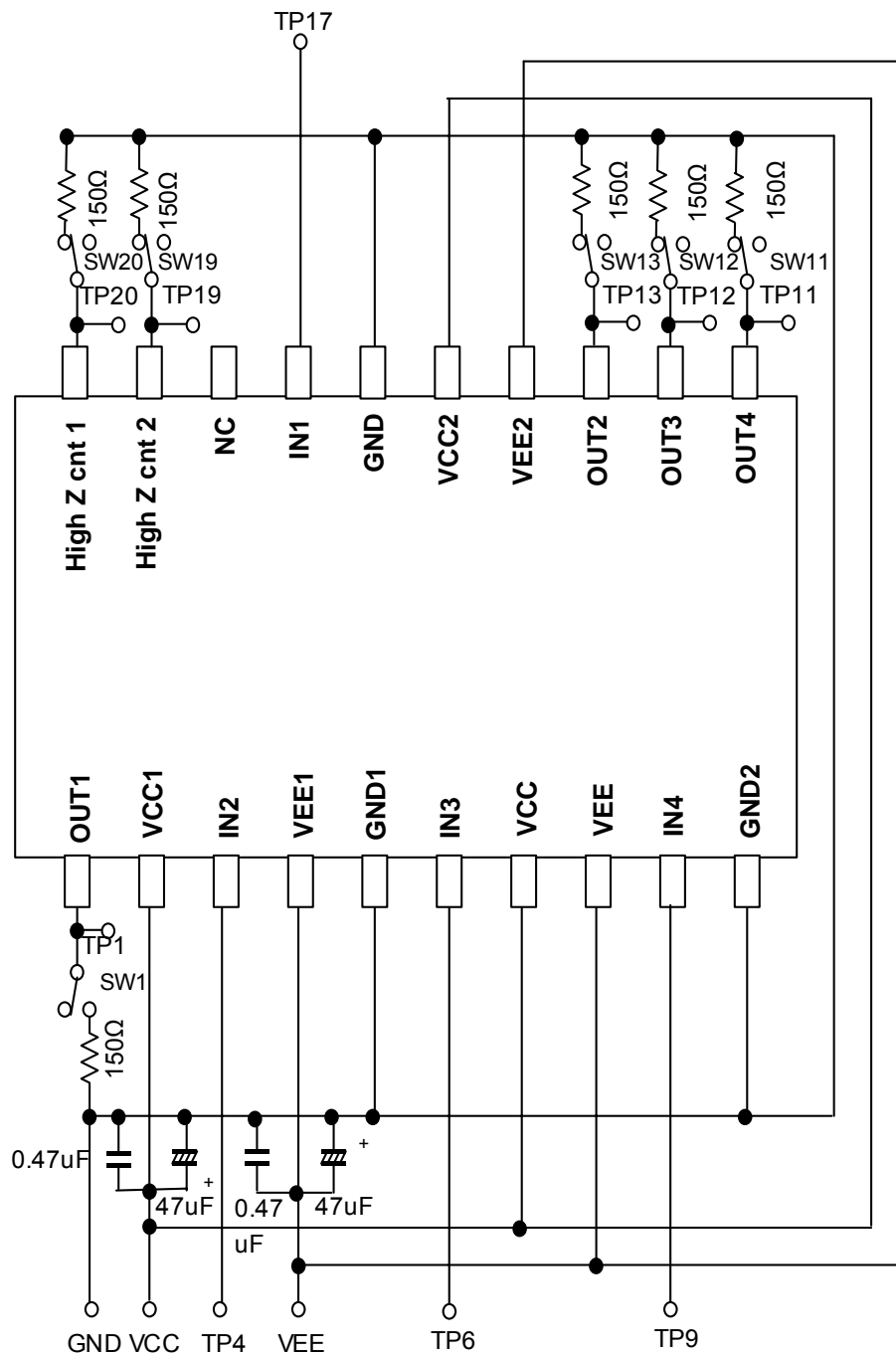

## ■ TYPICAL CHARACTERISTICS

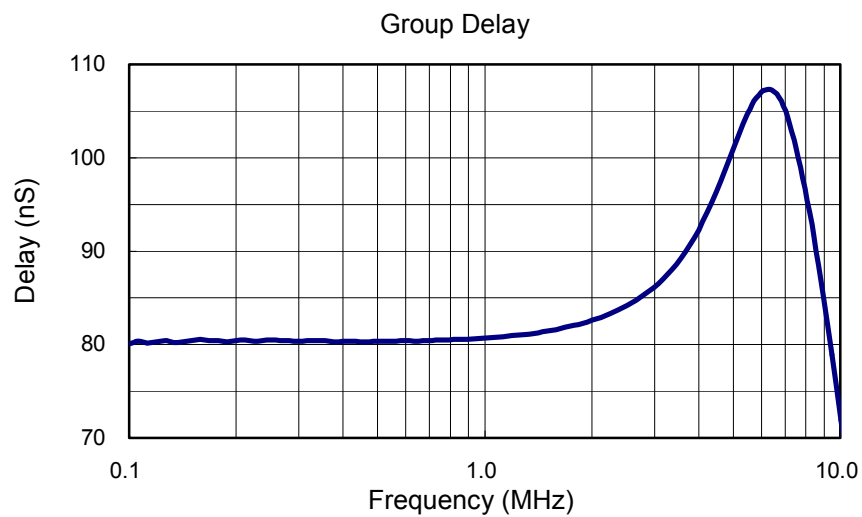
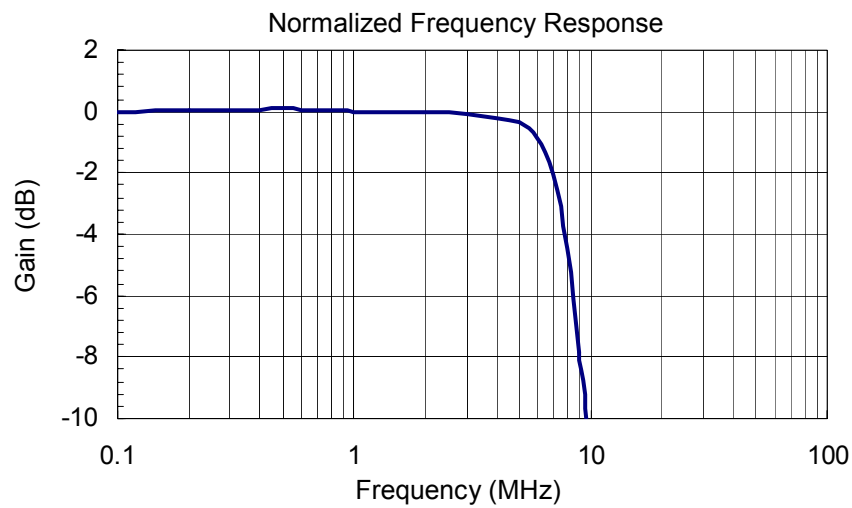
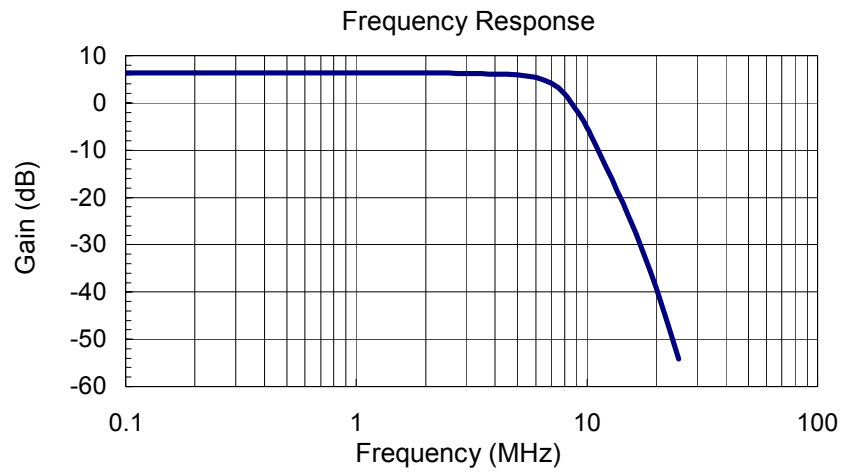

**[CAUTION]**

The specifications on this databook are only given for information, without any guarantee as regards either mistakes or omissions. The application circuits in this databook are described only to show representative usages of the product and not intended for the guarantee or permission of any right including the industrial rights.

## X-ON Electronics

Largest Supplier of Electrical and Electronic Components

*Click to view similar products for [Display Drivers & Controllers](#) category:*

*Click to view products by [Nisshinbo](#) manufacturer:*

Other Similar products are found below :

[ICB2FL01G](#) [HV5812PJ-G-M904](#) [TW8813-LB2-GR](#) [TW8811-PC2-GR](#) [MAX1839EEP+](#) [TW9907-TA1-GR](#) [LX27901IDW](#) [SSD2828QN4](#)  
[MAX7370ETG+](#) [DLPA1000YFFT](#) [ICB2FL01GXUMA2](#) [DLP2000FQC](#) [PAD1000YFFR](#) [S1D13746F01A600](#) [FIN324CMLX](#) [AD8387JSVZ](#)  
[DLPC6421ZPC](#) [HV852K7-G](#) [HV859K7-G](#) [HV857K7-G](#) [DIO2133CT14](#) [S1D13L03F00A100-40](#) [TW2836-BA1-GR](#) [SSD2829QL9](#)  
[MAX749CSA+T](#) [MAX4820EUP+T](#) [ICL7135CAI+](#) [ICL7135CMH+D](#) [ICL7137CMH+D](#) [MAX14515AEWA+](#) [MAX14521EETG+](#)  
[MAX25221BATJ/V+](#) [DS3882E+C](#) [S1D13748B00B100](#) [S1D13A05B00B200](#) [MAX3738ETG+T](#) [MAX14514ETD+](#) [MAX4990ETD+T](#)  
[MAX8722CEEG+](#) [MAX749CPA+](#) [MAX8520ETP+](#) [MAX8785AETI+](#) [ICL7135CQI+](#) [HV518PJ-G-M903](#) [HV5812P-G](#) [HV5812PJ-G](#)  
[HV7224PG-G](#) [HV853K7-G](#) [HV860K7-G](#) [HV6810WG-G](#)