

Designated client product

This product will be discontinued its production in the near term.
And it is provided for customers currently in use only, with a time limit.
It can not be available for your new project. Please select other new or existing products.

For more information, please contact our sales office in your region.

New Japan Radio Co.,Ltd.

www.njr.com

DUAL H BRIDGE DRIVER

■ GENERAL DESCRIPTION

The NJM2670 is a general-purpose 60V dual H-bridge drive IC. It consists of a pair of H-bridges, a thermal shut down circuit and its alarm output. The alarm output can detect application problems and the system reliability will be significantly improved if monitored by Micro Processor.

Therefore, it is suitable for two-phase stepper motor application driven by microprocessor.

■ FEATURES

- Wide Voltage Range 4V to 60V
- Wide Range of Current Control 5 to 1500mA
- Thermal overload Protection
- Dead Band Protector
- Package Outline DIP22, SOP24-E3 (Batwing)

■ PACKAGE OUTLINE

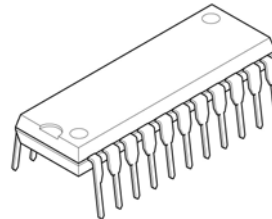

NJM2670D2
(DIP22)

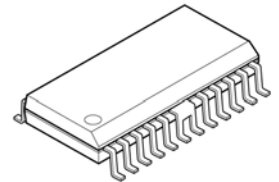

NJM2670E3
(SOP24-E3 Batwing)

■ PIN CONNECTION

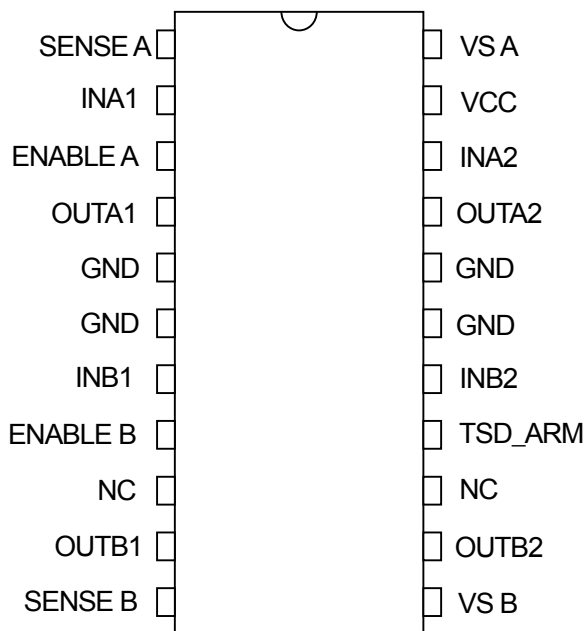

DIP-22

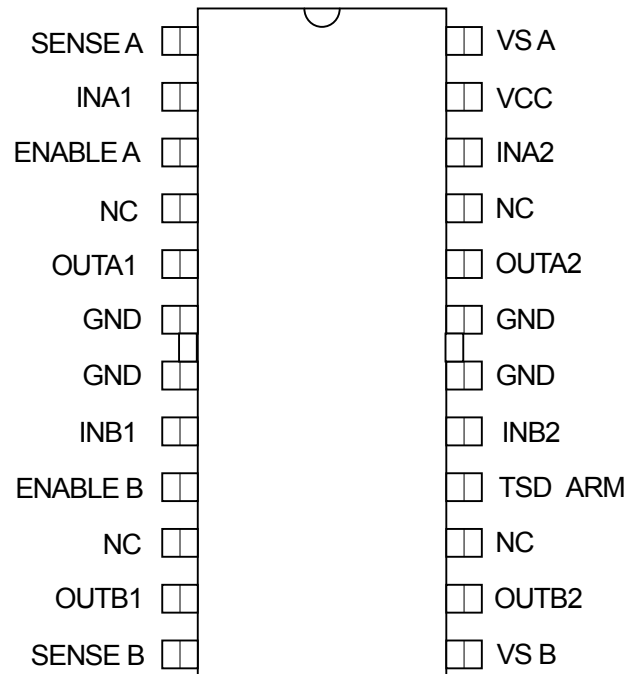

SOP24-E3

NJM2670

■ BLOCK DIAGRAM

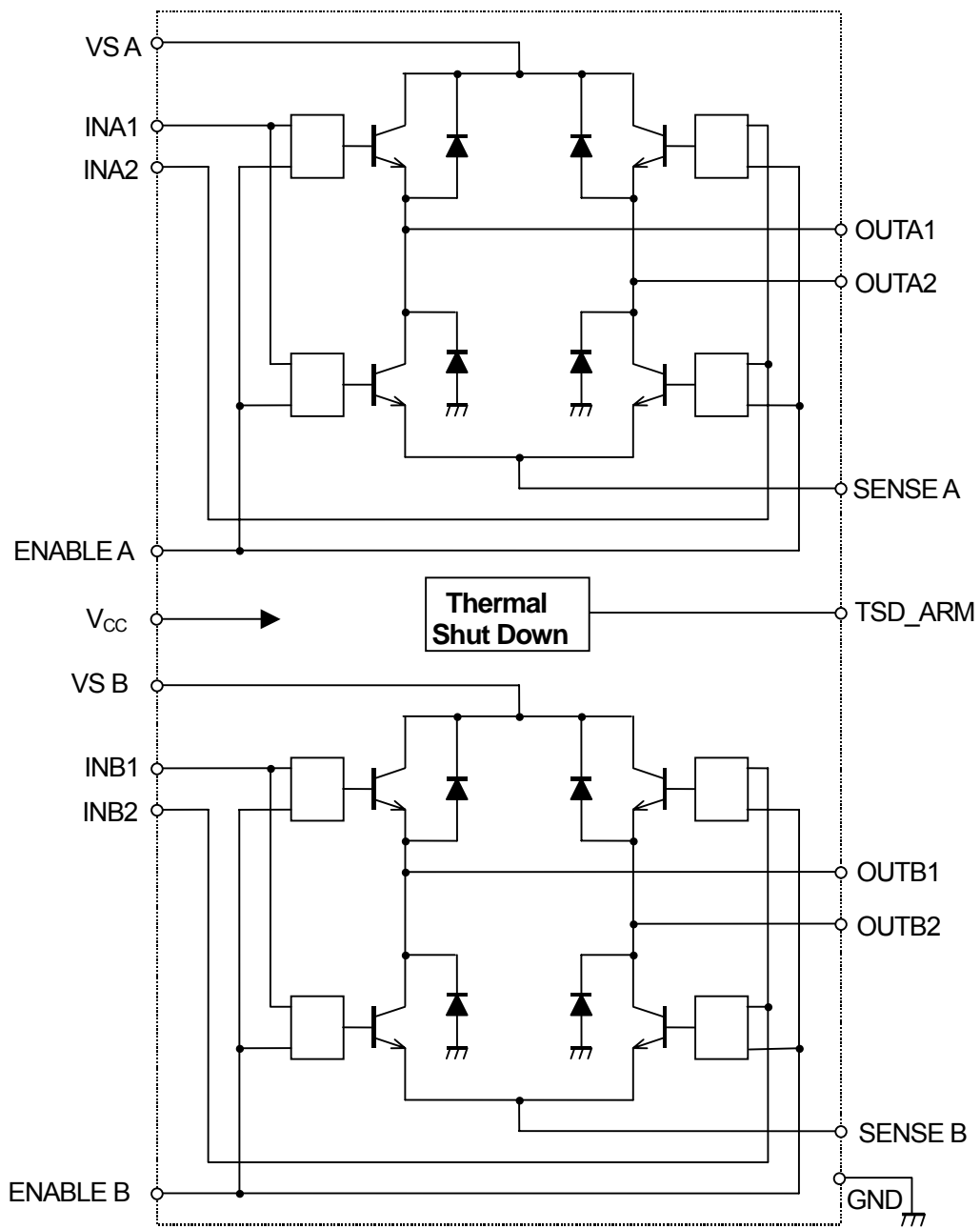

■ ABSOLUTE MAXIMUM RATINGS (Ta=25°C)

PARAMETER	SYMBOL	RATINGS	UNIT
Maximum Supply Voltage	V _{MM}	60	V
Logic Supply Voltage	V _{CC}	7	V
Input Voltage Range	V _{IN}	-0.3 to 7	V
Output Current	I _{OUT}	1.5	A
Power dissipation at T _{GND} =+25°C,DIP and SOP package	P _{D25}	5	W
Power dissipation at T _{GND} =+125°C,DIP package	P _{D125}	2.2	W
Power dissipation at T _{GND} =+125°C,SOP package	P _{D125}	2	W
Operating Junction Temperature	T _{opr}	-40 ~ 85	°C
Storage Temperature	T _{stg}	-55 ~ 150	°C

■ RECOMENDDO OPERATING CONDITIONS

PARAMETER	SYMBOL	TEST CONDITIONS	MIN.	TYP.	MAX.	UNIT
Supply Voltage	V _{MM}		4	-	55	V
Logic Voltage Range	V _{CC}		4.75	5.00	5.25	V
Maximum Output Current	I _{OUT}		-	-	1.3	A
Operating junction temperature	T _j		-20	-	125	°C

■ THERMAL CHARACTERISTICS

PARAMETER	SYMBOL	TEST CONDITIONS	MIN.	TYP.	MAX.	UNIT
Thermal resistance	R _{thj-GND}	DIP22 package.	-	11	-	°C/W
	R _{thj-A}	DIP22 package. Note	-	40	-	°C/W
	R _{thj-GND}	SOP24 package.	-	13	-	°C/W
	R _{thj-A}	SOP24 package. Note	-	42	-	°C/W

Note : All ground pins soldered onto a 20 cm² PCB copper area with free air convection, T_A=+25°C

NJM2670

■ ELECTRICAL CHARACTERISTICS

PARAMETER	SYMBOL	TEST CONDITIONS	MIN.	TYP.	MAX.	UNIT
GENERAL						
Quiescent current	I _{cc}	Enable=H, IN1=IN3=L, IN2=IN4=H	-	40	-	mA
Thermal shutdown	T _{tsd}		-	170	-	°C
Off-State leak current	I _{tsd-LEAK}	TSD ARM=5V	-	-	50	μA
Thermal alarm output saturation	V _{tsd}	I _o =5mA	-	0.5	0.7	V
Dead time protection	T _d		-	1	-	μs
LOGIC						
Input LOW voltage	V _{IL}		-	-	0.6	V
Input HIGH voltage	V _{IH}		2	-	-	V
Input HIGH current	I _{IH}	V _i =2.4V	-	-	20	μA
Input LOW current	I _{IL}	V _i =0.4V	-0.4	-	-	mA
OUTPUT						
Upper transistor saturation	V _{OU1}	I _o =1000mA	-	1.3	1.5	V
	V _{OU2}	I _o =1300mA	-	1.5	1.8	V
Lower transistor saturation	V _{OL1}	I _o =1000mA	-	0.5	0.8	V
	V _{OL2}	I _o =1300mA	-	0.8	1.3	V
Upper diode forward	V _{FU1}	I _o =1000mA	-	1.3	1.6	V
	V _{FU2}	I _o =1300mA	-	1.6	1.9	V
Lower diode forward	V _{FL1}	I _o =1000mA	-	1.3	1.6	V
	V _{FL2}	I _o =1300mA	-	1.6	1.9	V
Output leakage current	I _{o-LEAK}	V _{MM} =50V	-	-	1	mA
Upper diode recovery time	T _{rrU}		-	250	-	ns
Lower diode recovery time	T _{rrL}		-	250	-	ns

■ TRUTH TABLE

INPUT (L=Low, H=High, X=Don't care)			OUTPUT (H=Source, L=Sink)		OUTPUT mode
ENABLE A=H ENABLE B=H	INA1 INB1	INA2 INB2	OUTA1 OUTB1	OUTA2 OUTB2	
	L	L	L	L	short break mode
	L	H	L	H	CW
	H	L	H	L	CCW
	H	H	H	H	short break mode
ENABLE A=L ENABLE B=L	X	X	All Transistor turned OFF		

■ TYPICAL APPLICATION

1). Bipolar Stepper Motor

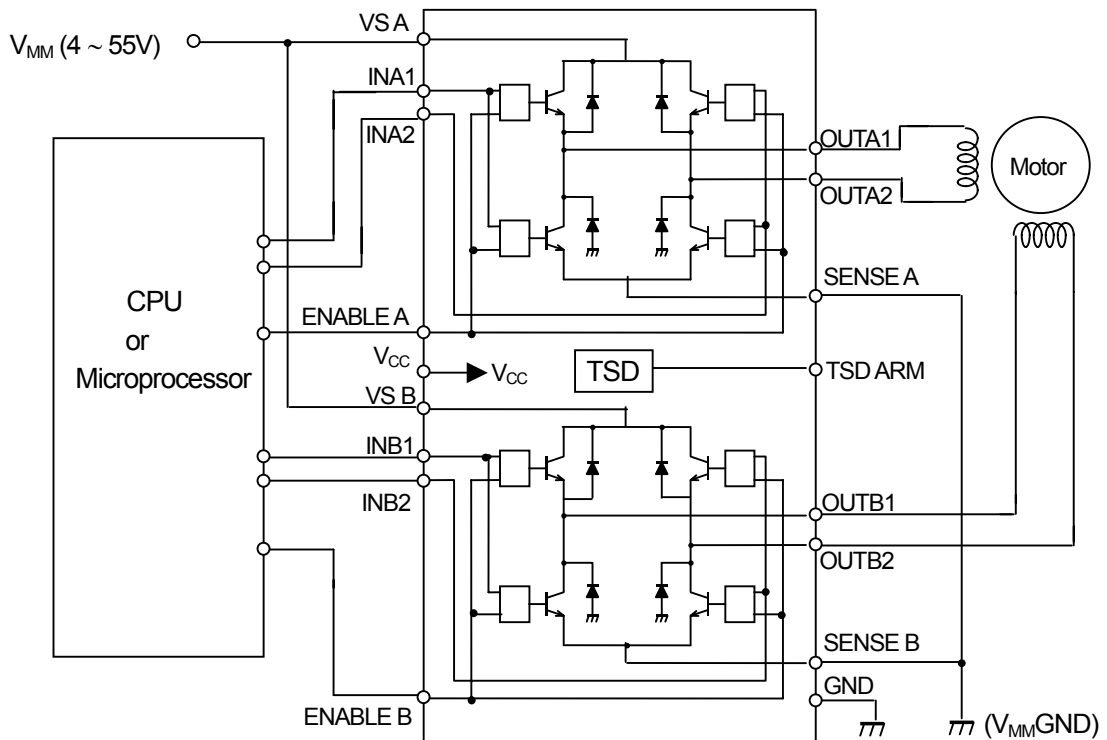

2). Single Phase DC Motor

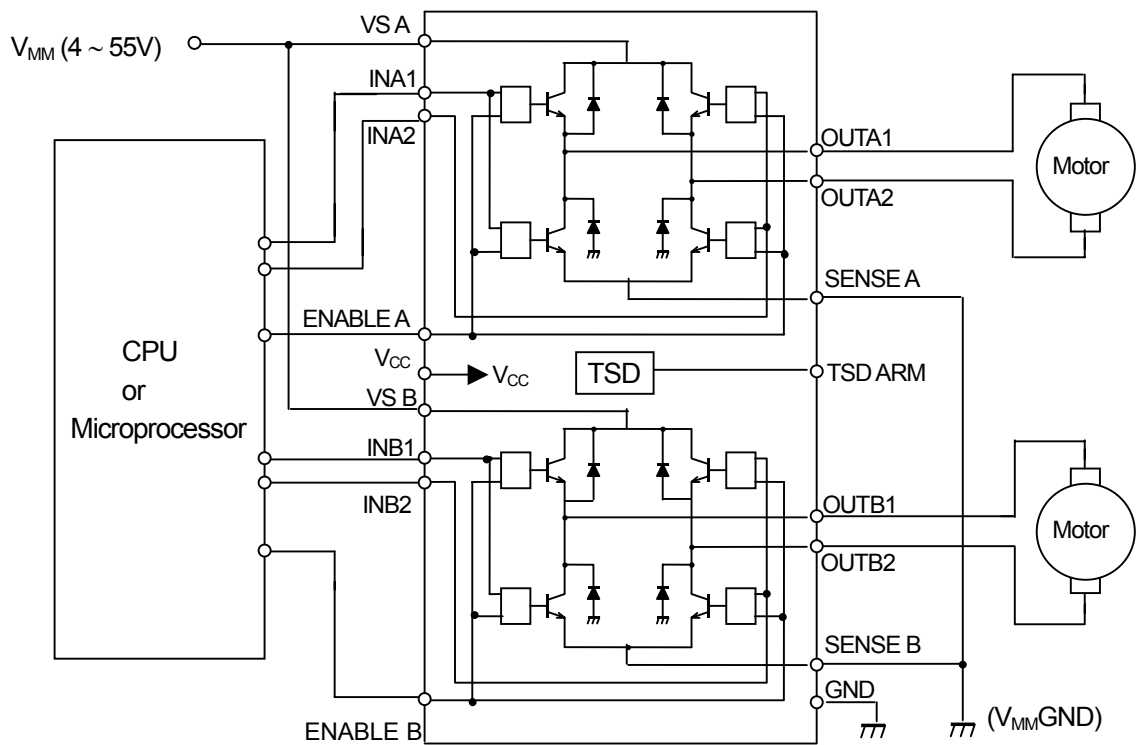

NJM2670

3) Current Control Application for Bipolar Stepper Motor

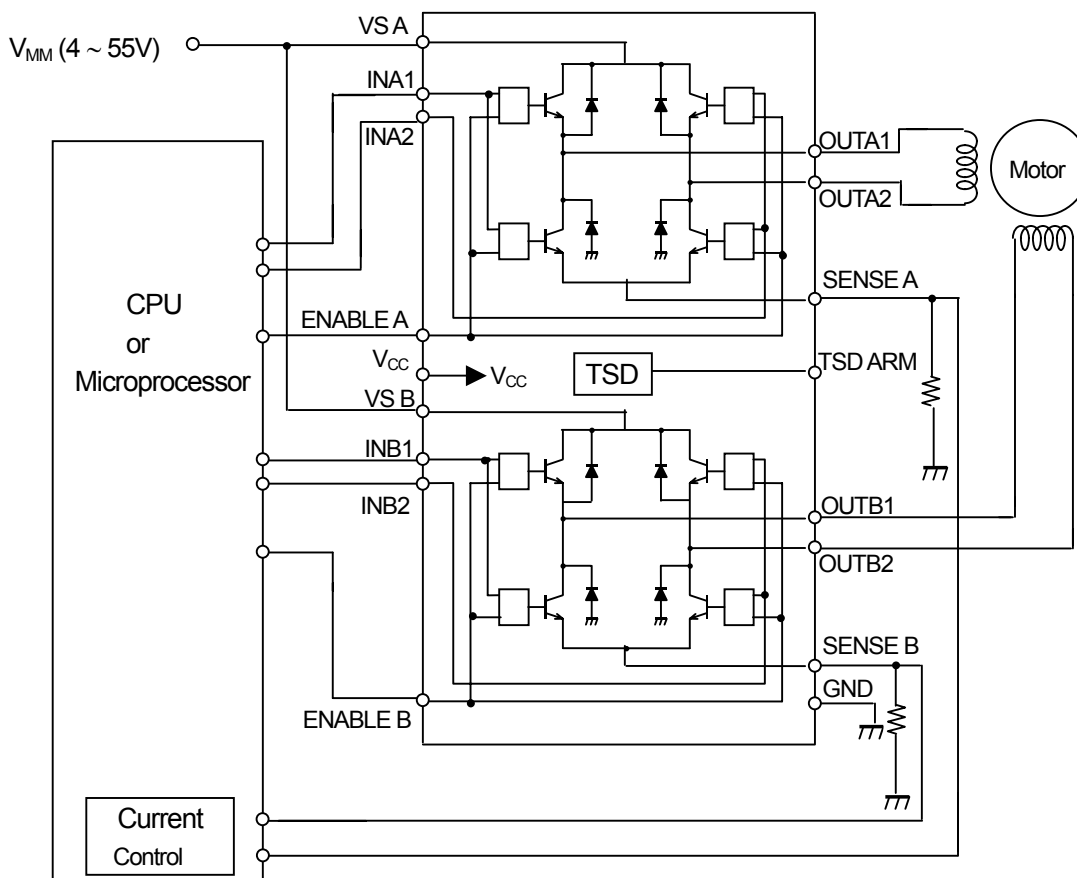

■ TIMING CHART

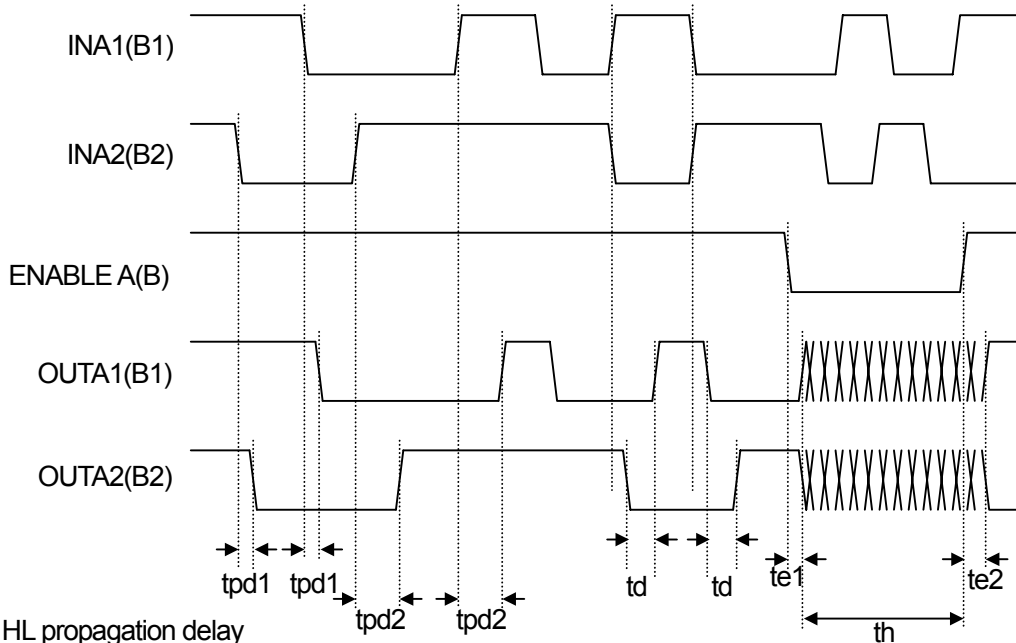

- tpd1:IN_HL propagation delay
- tpd2:IN_LH propagation delay
- td :Output dead band protection delay
- te1 :ENABLE_HL propagation delay
- te2 :ENABLE_LH propagation delay
- th :Output High impedance section

	Reference value	unit
tpd1	1.0	us
tpd2	2.5	us
td	1.5	us
te1	3.5	us
te2	2.0	us

■ TYPICAL APPLICATION 1

ICC vs. VCC

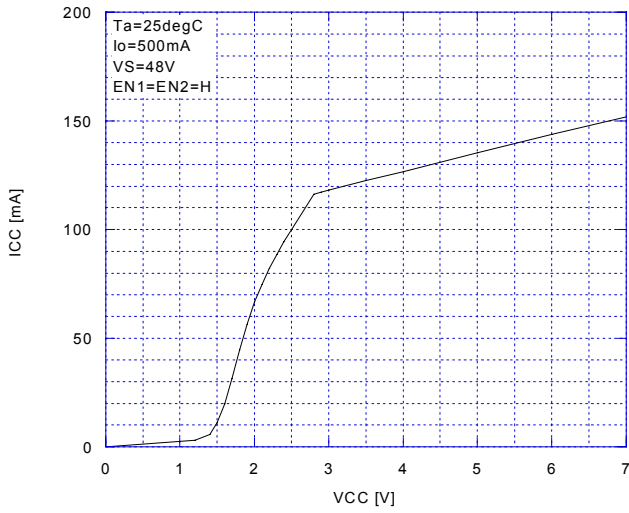

VIN(INA1)-hysteresis vs. Temperature

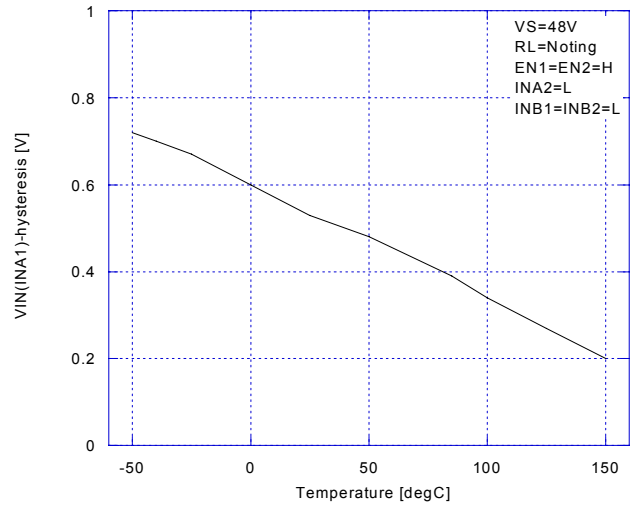

VIN(INA1) vs. Temperature

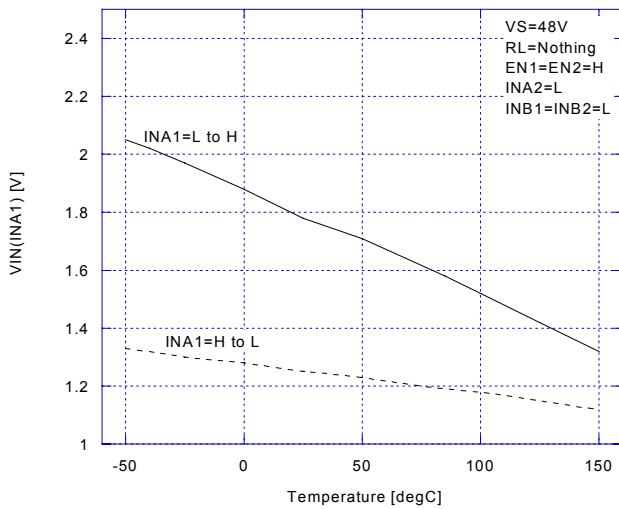

VIN(INA1)-IB vs. Temperature

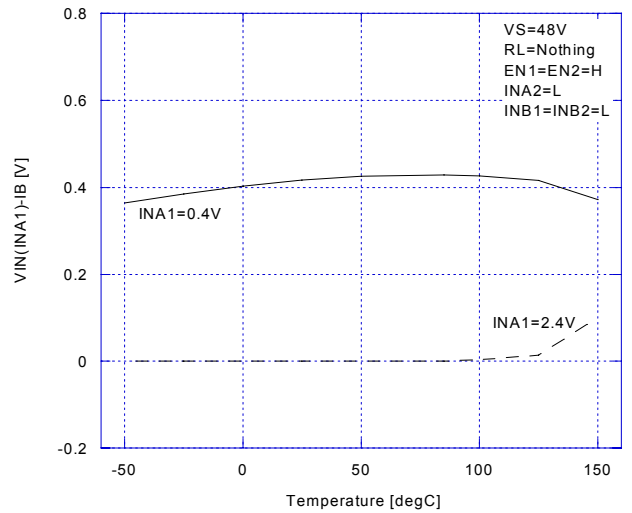

Vsat(D) vs. Io

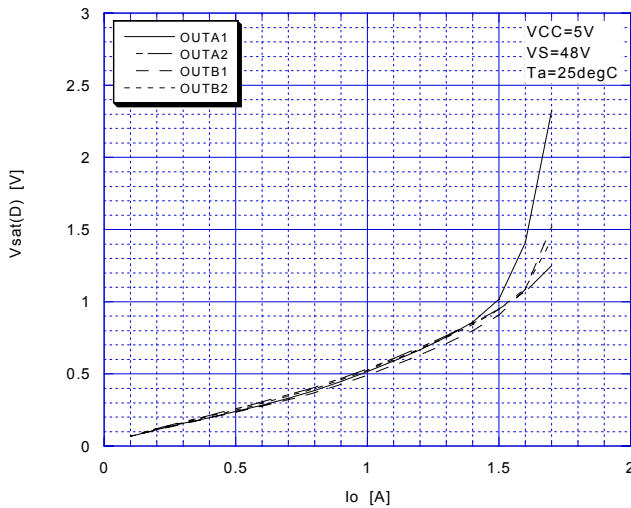

Vsat(U) vs. Io

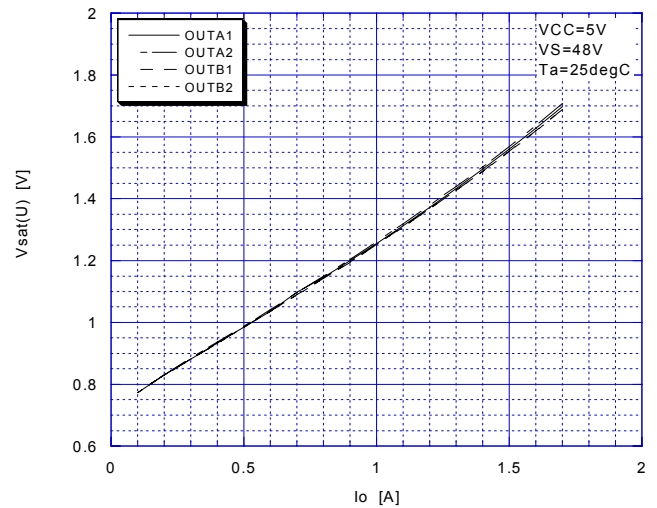

NJM2670

■ TYPICAL APPLICATION 2

Diode(D) vs. I_o

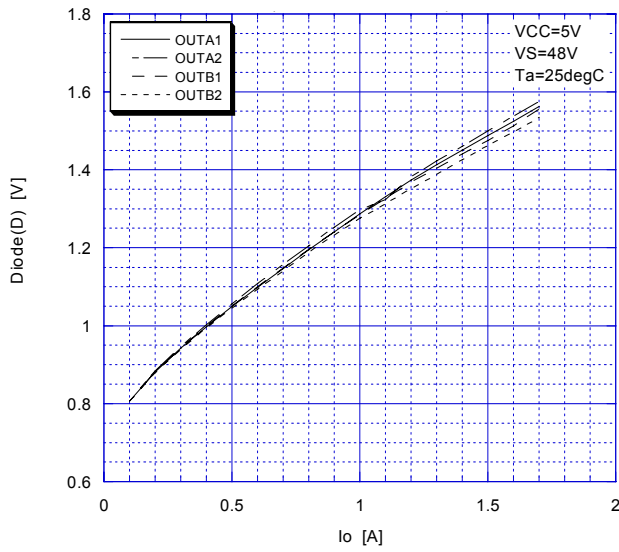

Diode(U) vs. I_o

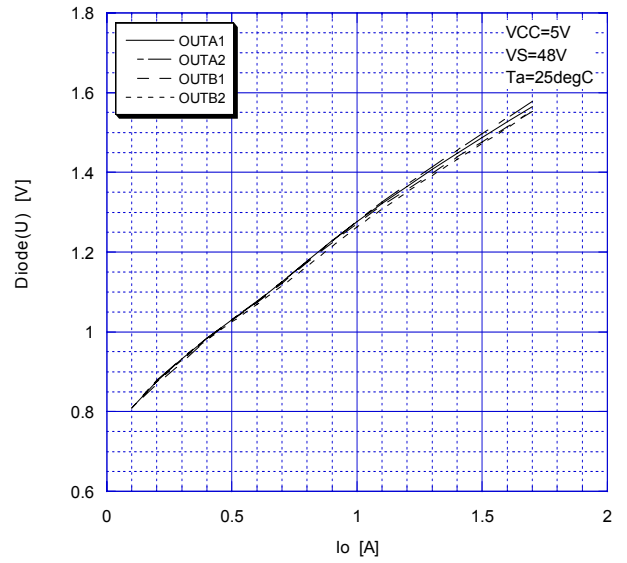

ICC vs. Temperature

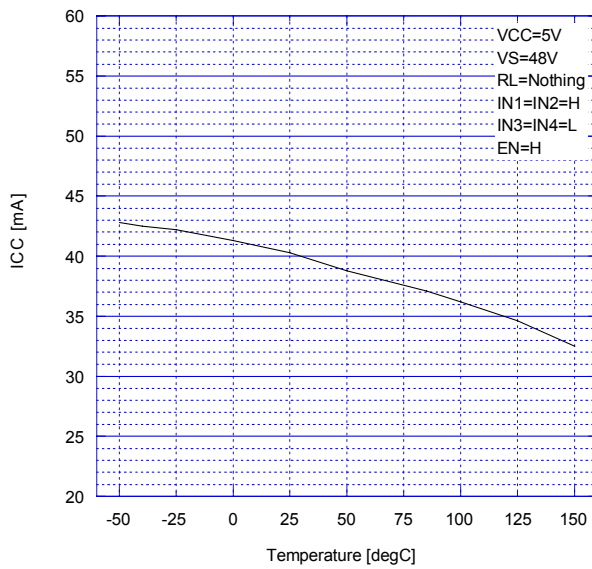

ICC vs. Temperature

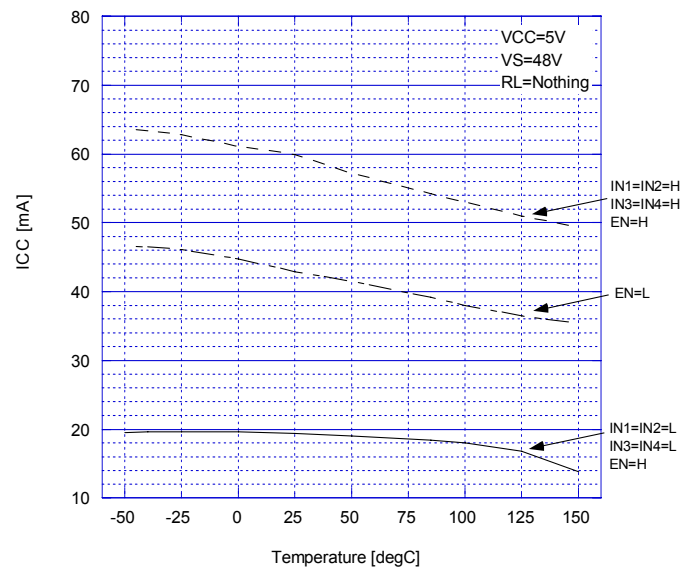

Vsat(D) vs. Temperature

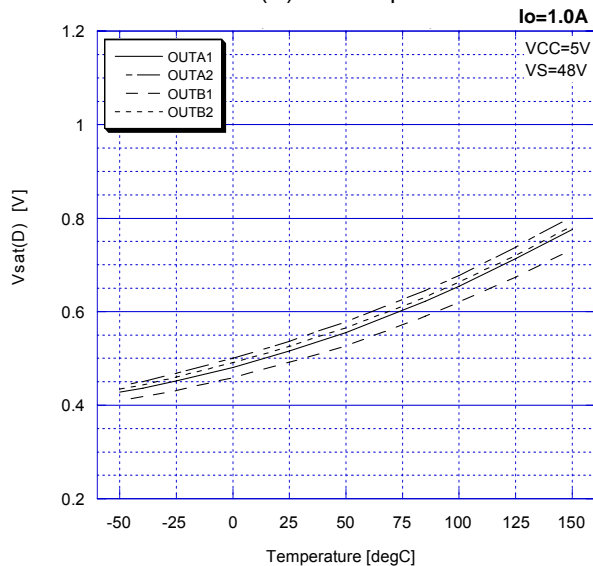

Vsat(U) vs. Temperature

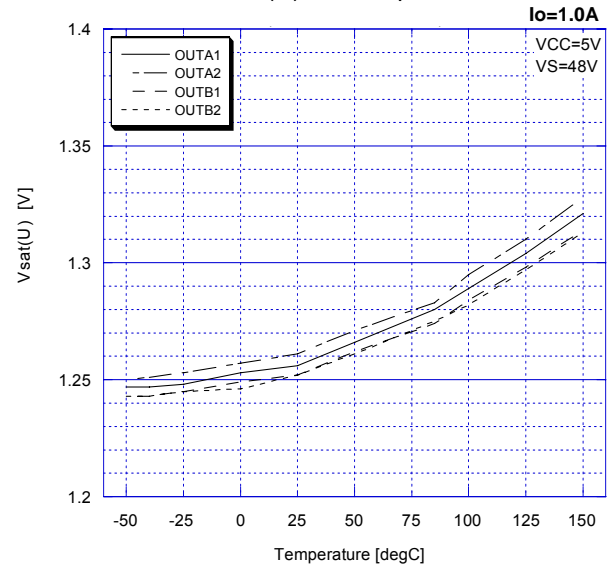

■ TYPICAL APPLICATION 3

Vsat(D) vs. Temperature

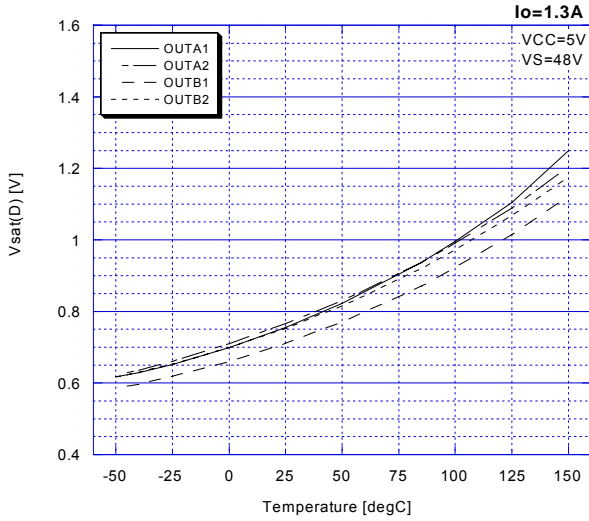

Vsat(U) vs. Temperature

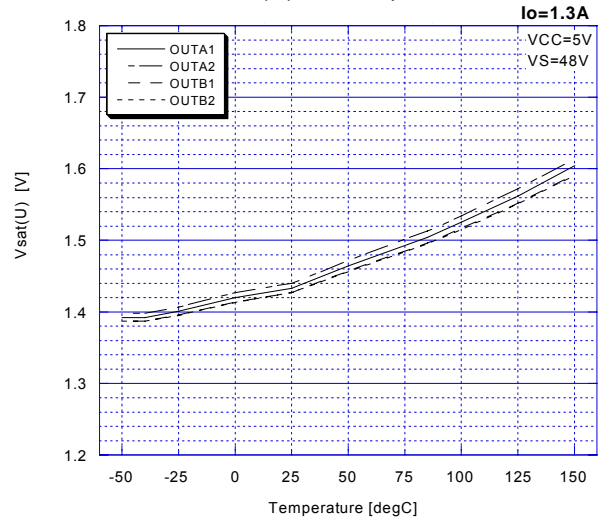

Diode(D) vs. Temperature

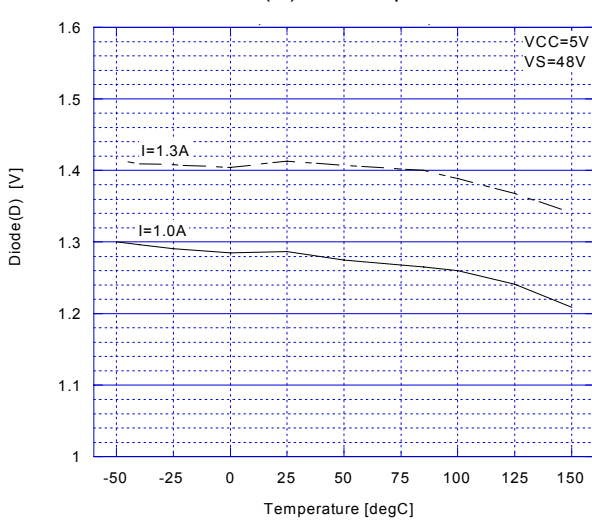

NJM2670
Diode(U) vs. Temperature

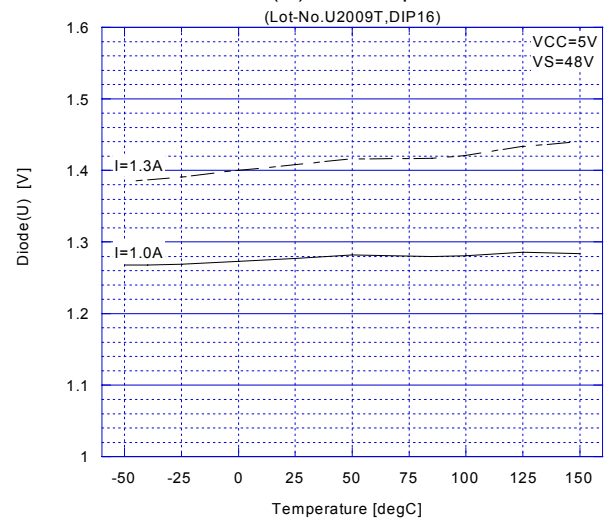

Diode(U) vs. Temperature

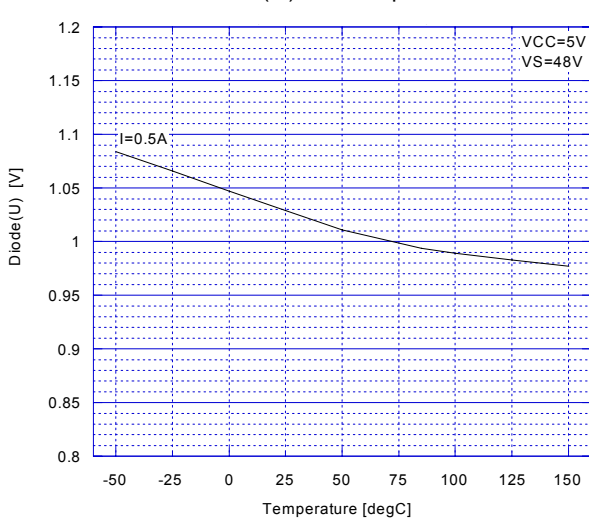

[CAUTION]

The specifications on this databook are only given for information, without any guarantee as regards either mistakes or omissions. The application circuits in this databook are described only to show representative usages of the product and not intended for the guarantee or permission of any right including the industrial rights.

X-ON Electronics

Largest Supplier of Electrical and Electronic Components

Click to view similar products for [Gate Drivers](#) category:

Click to view products by [Nisshinbo](#) manufacturer:

Other Similar products are found below :

[89076GBEST](#) [00053P0231](#) [56956](#) [57.404.7355.5](#) [LT4936](#) [57.904.0755.0](#) [5882900001](#) [00600P0005](#) [00-9050-LRPP](#) [00-9090-RDPP](#)
[5951900000](#) [01-1003W-10/32-15](#) [0131700000](#) [00-2240](#) [LTP70N06](#) [LVP640](#) [5J0-1000LG-SIL](#) [LY1D-2-5S-AC120](#) [LY2-US-AC240](#) [LY3-](#)
[UA-DC24](#) [00576P0020](#) [00600P0010](#) [LZN4-UA-DC12](#) [LZNQ2M-US-DC5](#) [LZNQ2-US-DC12](#) [LZP40N10](#) [00-8196-RDPP](#) [00-8274-RDPP](#)
[00-8275-RDNP](#) [00-8722-RDPP](#) [00-8728-WHPP](#) [00-8869-RDPP](#) [00-9051-RDPP](#) [00-9091-LRPP](#) [00-9291-RDPP](#) [0207100000](#) [0207400000](#)
[01312](#) [0134220000](#) [60713816](#) [M15730061](#) [61161-90](#) [61278-0020](#) [6131-204-23149P](#) [6131-205-17149P](#) [6131-209-15149P](#) [6131-218-17149P](#)
[6131-220-21149P](#) [6131-260-2358P](#) [6131-265-11149P](#)