

SERIES REGULATOR WITH RESET FUNCTION

■ GENERAL DESCRIPTION

The NJM78LR05 is a series regulator with reset function.

In case of shut down or output voltage drop, the IC generates reset signal to a microcomputer.

That is suitable for items with microcomputer, such as TV sets, remote controller, refrigerator and others.

■ FEATURES

- Output Current $I_o = 150\text{mA}$ max.
- Reset Function Including
- Reset Delay Time can be Adjusted by an External Capacitance.
- Internal Over Current Protection
- Thermal Shut Down
- Bipolar Technology
- Package Outline DIP8, DMP8, SIP8, SOT-89 (5Pin)

■ PACKAGE OUTLINE



NJM78LR05BD/CD/DD



NJM78LR05BM/CM/DM

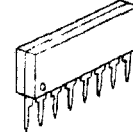

NJM78LR05BL/CL/DL



NJM78LR05BU/CU/DU

■ RESET THRESHOLD VOLTAGE LINE-UP

Reset Threshold Voltage	Version	Part Number
4.0 V	D	NJM78LR05DX
4.2 V	C	NJM78LR05CX
4.3 V	B	NJM78LR05DX

"X" is package suffix.

■ BLOCK DIAGRAM

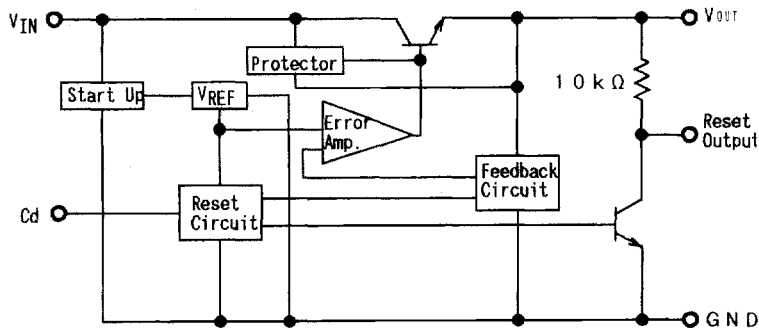

■ PIN CONFIGURATION

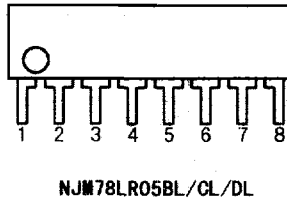
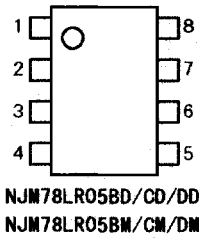

PIN FUNCTION

1. INPUT
2. NC
3. Cd
4. NC
5. GND
6. RESET-OUTPUT
7. NC
8. OUTPUT

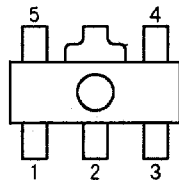

PIN FUNCTION

1. Cd
2. GND
3. RESET-OUTPUT
4. OUTPUT
5. INPUT

■ ABSOLUTE MAXIMUM RATINGS

($T_a = 25^\circ\text{C}$)

PARAMETER	SYMBOL	MAXIMUM RATINGS	UNIT
Input Voltage	V_{IN}	+20	V
Power Dissipation	P_D	(DIP8) 500 (DMP8) 500※ (SIP8) 800 (SOT-89) 350	mW
Operating Temperature Range	T_{opr}	-40 ~ +85	$^\circ\text{C}$
Storage Temperature Range	T_{str}	-50 ~ +150	$^\circ\text{C}$

※At on PC board.

■ RECOMMENDED OPERATING CONDITIONS

($T_a = 25^\circ\text{C}$)

PARAMETER	SYMBOL	CONDITIONS	UNIT
Input Voltage	V_{IN}	7.5 ~ 18	V
Output Current	I_o	1 ~ 100	mA

NJM78LR05

■ ELECTRICAL CHARACTERISTICS ($V_{IN}=10V$, $I_o=40mA$, $C_{IN}=1\mu F$, $C_o=10\mu F$, $T_a=25^\circ C$)
 [Power Supply Block]

PARAMETER	SYMBOL	CONDITIONS	MIN.	TYP.	MAX.	UNIT
Output Voltage	V_o	$I_o=1mA$	4.80	5.00	5.20	V
Quiescent Current	I_o	$I_o=100mA$	—	1.40	3.40	mA
Output Short Current	I_{osc}	OUTPUT-GND short	150	300	450	mA
Line Regulation 1	$\Delta V_o/V_{IN1}$	$7V \leq V_{IN} \leq 18V$	—	6.0	65.0	mV
Line Regulation 2	$\Delta V_o/V_{IN2}$	$8V \leq V_{IN} \leq 18V$	—	3.0	42.0	mV
Load Regulation 1	$\Delta V_o/I_{o1}$	$I_o=1 \sim 100mA$	—	9.0	60.0	mV
Load Regulation 2	$\Delta V_o/I_{o2}$	$I_o=1 \sim 40mA$	—	3.0	30.0	mV
Ripple Rejection	RR	$f=120Hz$, $e_{in}=1V_{P-P}$, $V_{IN}=8 \sim 18V$	—	79	—	dB
Output Noise Voltage	V_{NO}	$10Hz \leq f \leq 100kHz$, $I_o=1mA$	—	80	—	μV
Dropout Voltage	ΔV_{I-O}		—	1.5	2.2	V

[Reset Block]

(H) Reset Output Voltage	V_{ORH}		4.80	5.00	5.20	V
(L) Reset Output Voltage	V_{ORL}	$V_{IN}=3V$, $I_o=1mA$	—	10	200	mV
Reset Threshold Voltage	V_{RT}	B Version	4.12	4.30	4.48	V
		C Version	4.03	4.20	4.37	
		D Version	3.84	4.00	4.16	
Reset Threshold Hysteresis Voltage	V_{RTH}		50	100	200	mV
Reset Output Delay Time	t_d	$C_d=0.1\mu F$	7.50	10.0	12.5	ms

■ APPLICATION CIRCUIT

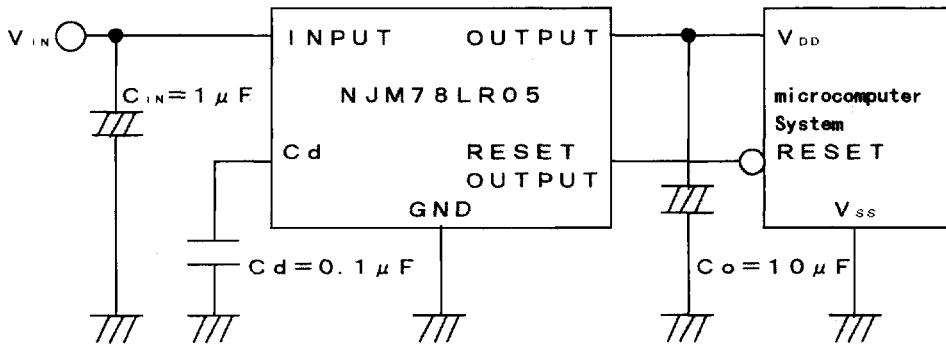

$$t_d [\text{ms}] = 100 \times C_d [\mu\text{F}]$$

Note1: When the capacitance C_d is too large, the actual delay time is shorter than the calculated result because an electrical charge of C_d is discharged incompletely.

Solution of above problem:

- (1) Connect SBD between output terminal and C_d terminal. Please refer to the following circuit.
- (2) Select larger capacitance, C_{IN} than C_d .

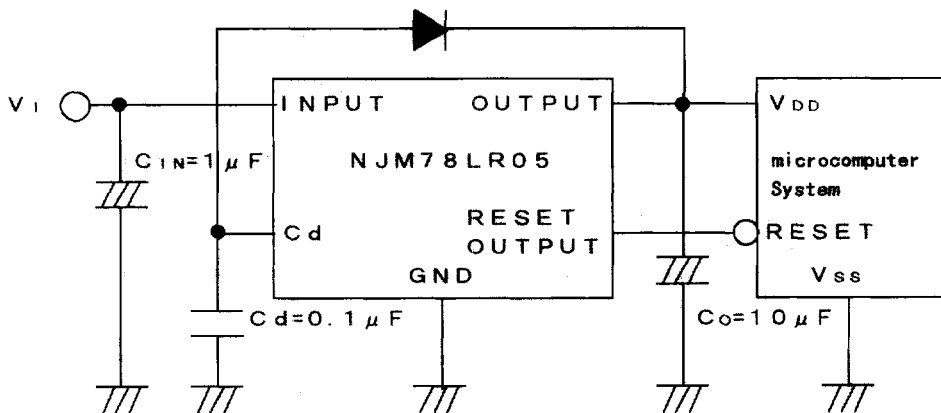

■ TIMING CHART

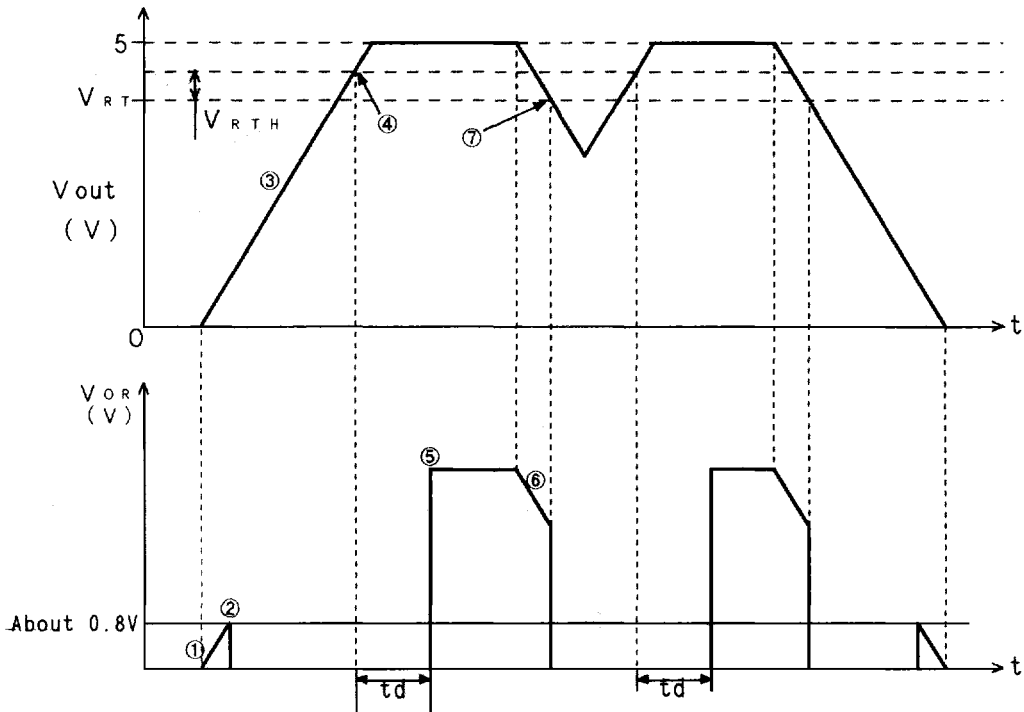

- ① When the input voltage is up to about 0.8V, some voltage is outputted at the reset output because the NJM78LR05 operation is unstable.
- ② When the input voltage goes over about 0.8V, the reset output becomes "L".
- ③ The output voltage is rising up with the input voltage.
- ④ When the output voltage goes over $(V_{RT}+V_{RTH})$, the delay circuit of reset output activates.
 V_{RT} :Reset Threshold Voltage
 V_{RTH} :Reset Threshold Hysteresis Voltage
- ⑤ After the reset output delay time t_d has passed, the reset output becomes "H".
- ⑥ The output voltage is falling down with the input voltage.
- ⑦ When the output voltage is less than V_{RT} , the reset output becomes "L".

■ TYPICAL CHARACTERISTICS

Reset Output Voltage vs. Output Voltage
($I_O=40\text{mA}$, $T_a=25^\circ\text{C}$)

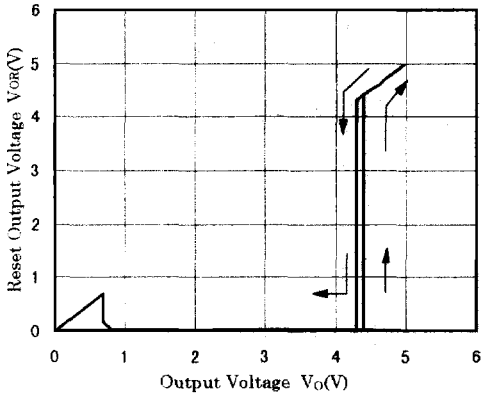

Line Regulation
($T_a=25^\circ\text{C}$)

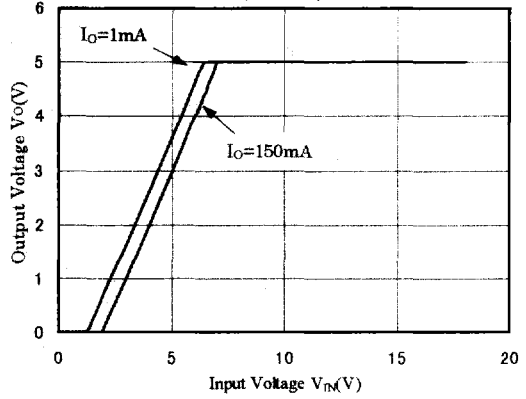

Load Regulation
($V_{IN}=10\text{V}$, $T_a=25^\circ\text{C}$)

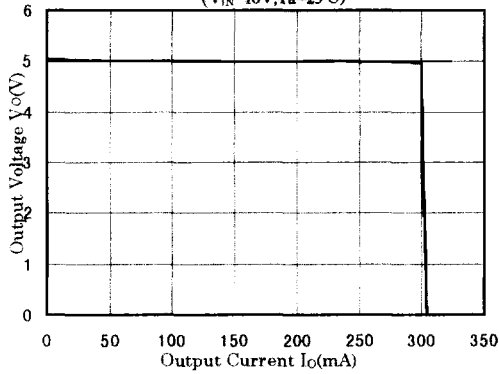

Dropout Voltage
($T_a=25^\circ\text{C}$)

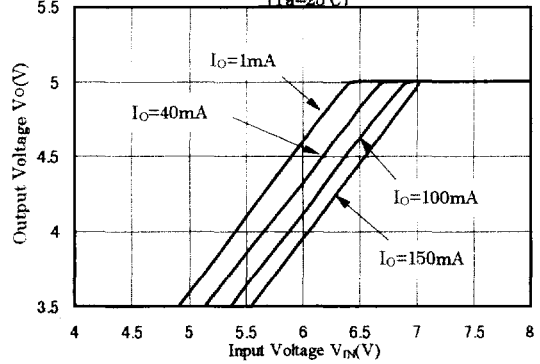

Quiescent Current vs. Input Voltage
($I_O=0\text{mA}$, $T_a=25^\circ\text{C}$)

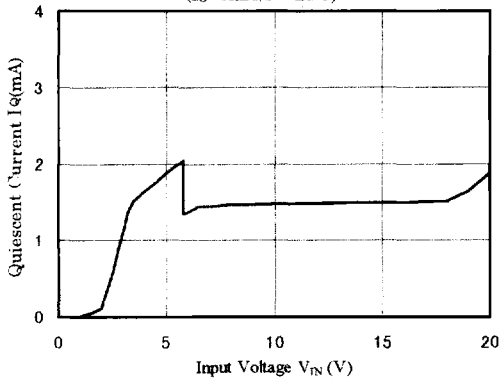

Output Short Current vs. Input Voltage

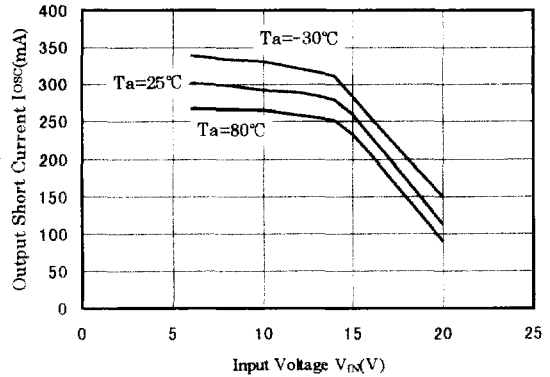

6

TYPICAL CHARACTERISTICS

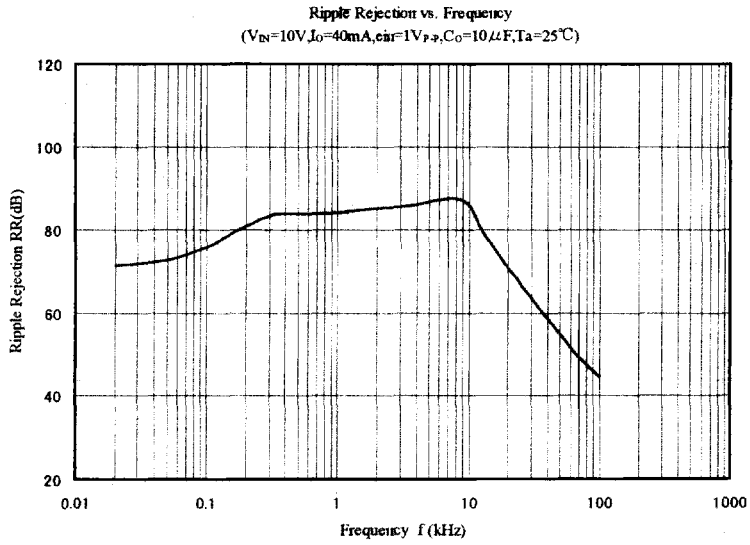
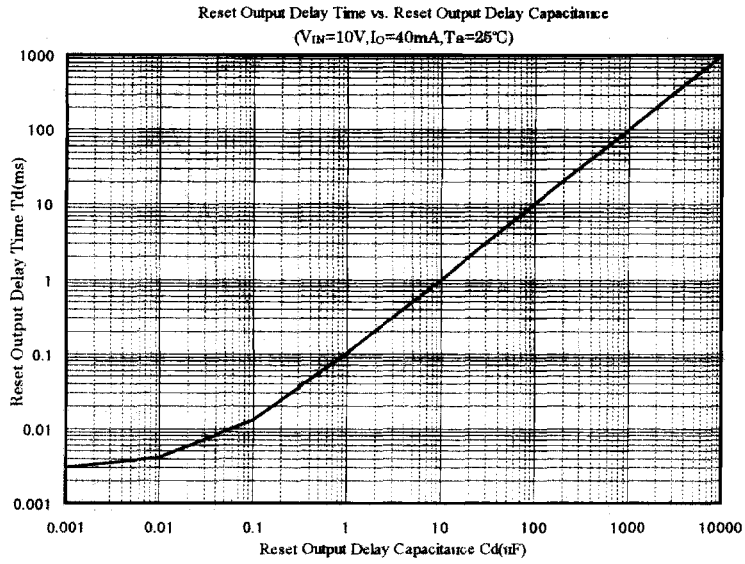

6

■ TYPICAL CHARACTERISTICS

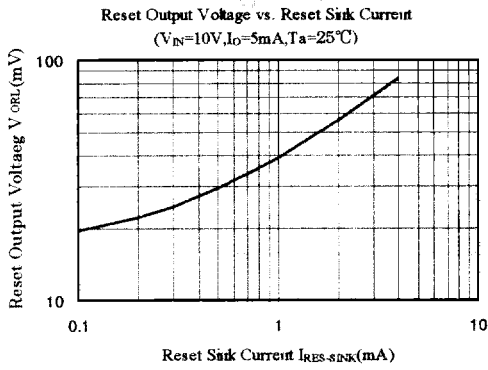
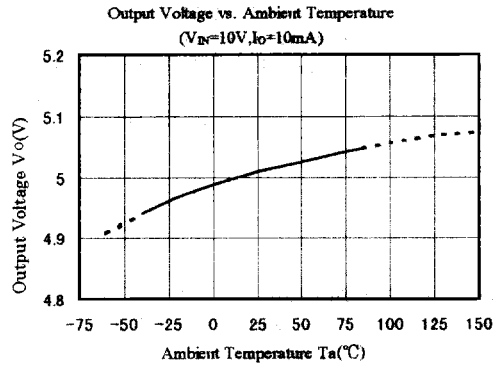
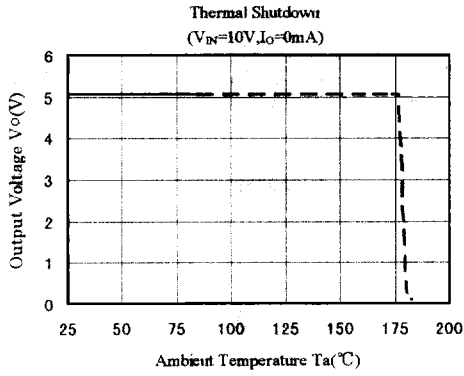

X-ON Electronics

Largest Supplier of Electrical and Electronic Components

Click to view similar products for [Linear Voltage Regulators](#) category:

Click to view products by [Nisshinbo](#) manufacturer:

Other Similar products are found below :

[LV56831P-E](#) [LV5684PVD-XH](#) [MCDTSA6-2R](#) [L7815ACV-DG](#) [LV56801P-E](#) [TCR3DF13,LM\(CT](#) [TCR3DF39,LM\(CT](#) [TLE42794G](#)
[L78L05CZ/1SX](#) [L78LR05DL-MA-E](#) [LM317T](#) [636416C](#) [714954EB](#) [LV5680P-E](#) [L78M15CV-DG](#) [L79M05T-E](#) [TLS202A1MBVHTSA1](#)
[L78LR05D-MA-E](#) [NCV317MBTG](#) [NTE7227](#) [NCV78M09BDTRKG](#) [LV5680NPVC-XH](#) [LT1054CN8](#) [ME6208A50M3G](#) [SL7533-8](#)
[ME6231A50M3G](#) [ME6231A50PG](#) [ME6231C50M5G](#) [AMS1117S-3.3](#) [AMS1117-5.0](#) [AMS1117S-5.0](#) [AMS1117-3.3](#) [MD5118](#) [MD5121](#)
[MD5127](#) [MD5128](#) [MD5130](#) [MD5144](#) [MD5150](#) [MD5115](#) [MD5125](#) [MD5133](#) [MD5136](#) [MD5140](#) [MD5110](#) [MD52E18WB6](#) [MD52E33WB6](#)
[MD52E15QA3](#) [MD52E21QA3](#) [MD52E25QA3](#)