

DUPLEX LCD DRIVER

■ GENERAL DESCRIPTION

The NJU6432B is a duplex LCD driver to drive segment type LCD panel.

2-common and 53-segment drivers can drive up to 104 segments.

The NJU6432B is useful for the Digital Tuning System or others segment type display driver.

■ PACKAGE OUTLINE

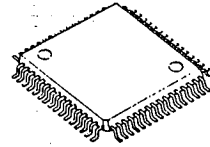

NJU6432BF

■ FEATURES

- 53 Segment Drivers
- Duty Ratio 1/2 ;104-Segment Drive
- Serial Data Transmission (Shift Clock 2MHz max.)
- Display Off Function (INH Terminal)
- Operating Voltage --- 6.5V Max.
- Package Outline --- QFP 64
- C-MOS Technology

■ BLOCK DIAGRAM

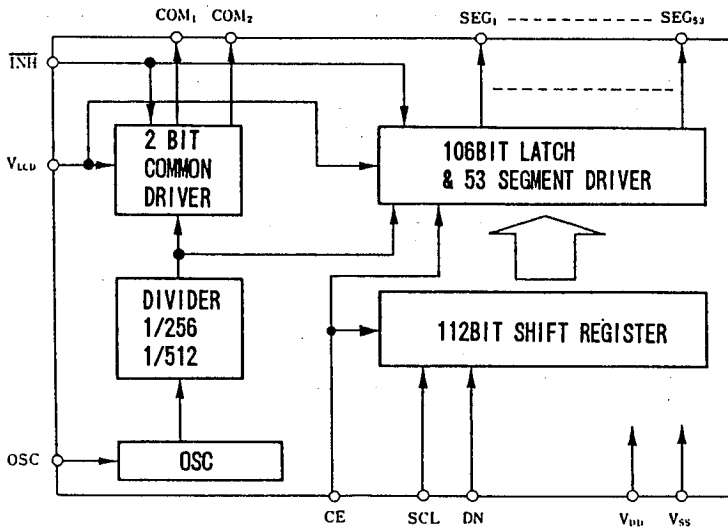

5

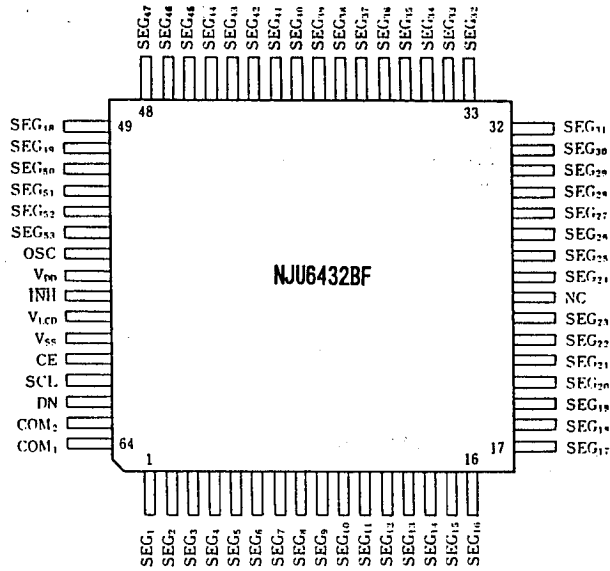
■ PIN CONFIGURATION

5 ■ TERMINAL DESCRIPTION

NO.	SYMBOL	F U N C T I O N
1~23 25~53	SEG ₁ ~ SEG ₂₃ SEG ₂₄ ~ SEG ₄₃	Segment Output Terminal
54	SEG ₅₃	Normally On Segment Output Terminal (When the "L" level input to the INH terminal, this segment also turns off.)
55	OSC	Oscillating Terminal
56,59	V _{DD} , V _{SS}	Power Supply
57	INH	Display-Off Control Terminal: When "L" level input to this terminal, all of the display turns off including SEG ₅₃ .
58	V _{LCD}	Power Supply for LCD Driving
60	CE	Chip Enable Terminal
61	SCL	Serial Data Transmission Clock Terminal
62	DN	Serial Data Input Terminal
63 64	COM ₂ COM ₁	Common Output Terminal.
24	NC	Non Connection

■ FUNCTIONAL DESCRIPTION

(1) Operation of each block

(1-1) Oscillation Circuits

Oscillation by connecting external resistor and capacitor.

This circuits supply the basical clock signal to other circuits like as common driver and segment driver.

(1-2) Driving Circuits

This circuit divide the oscillating frequency by 1/256 and 1/512, and generate the common and segment output timing signals.

(1-3) Shift-Register

During the CE signal is "H", the data input to this shift-register by synchronizing the shift clock.

(1-4) Latch and Segment Driver

During the CE signal is "L", the data in the shift-register transfer to the latch and the segment driver output the LCD driving waveform according to the latched data.

(2) Data Input Format (The Data Correspond to the Output)

(2-1) Data Input Format

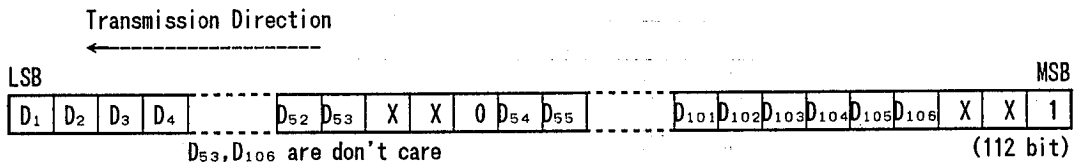

(2-2) Input Data Correspond to Segment Status

Data Dxxx	Segment Status
"H"	ON
"L"	OFF

(2-3) Input Data Correspond to Segment Terminals

Segment	Data	COM ₁	COM ₂
SEG ₁	D ₁	○	
	D ₂		○
SEG ₂	D ₃	○	
	D ₄		○
SEG ₃	D ₅	○	
	D ₆		○
SEG ₂₆	D ₅₁	○	
	D ₅₂		○
SEG ₂₇	D ₅₄	○	
	D ₅₅		○
SEG ₄₉	D ₉₈	○	
	D ₉₉		○
SEG ₅₀	D ₁₀₀	○	
	D ₁₀₁		○
SEG ₅₁	D ₁₀₂	○	
	D ₁₀₃		○
SEG ₅₂	D ₁₀₄	○	
	D ₁₀₅		○
SEG ₅₃	ON	○	
	ON		○

5

■ ABSOLUTE MAXIMUM RATINGS

PARAMETER	SYMBOL	RATINGS	UNIT
Operating Voltage	V _{DD}	- 0.3 ~ + 7.0	V
Operating Voltage	V _{LCD}	- 0.3 ~ V _{DD} +0.3	V
Input Voltage (1)	V _{IN}	- 0.3 ~ + 7.0	V
Input Voltage (2)	V _{IN}	- 0.3 ~ V _{DD} +0.3	V
Output Voltage (2)	V _O	- 0.3 ~ V _{DD} +0.3	V
Output Current (3)	I _O	100	μA
Output Current (4)	I _O	1.0	mA
Power Dissipation	P _D	300	mW
Operating Temperature	T _{opr}	- 30 ~ + 85	°C
Storage Temperature	T _{stg}	- 40 ~ + 125	°C

- * 1) CE, SCL, DN Terminals
- * 2) OSC Terminal during OFF-output
- * 3) SEG₁~SEG₅₃ Terminals
- * 4) COM₁,COM₂ Terminals

ELECTRICAL CHARACTERISTICS
DC Characteristics

 (Ta=-30~+85°C. V_{DD}=6.5V, V_{SS}=0V)

PARAMETER	SYMBOL	CONDITIONS	MIN	TYP	MAX	UNIT
Supply Voltage	V _{DD}	V _{DD} Terminal	2.5		6.5	V
Supply Voltage	V _{LCD}	V _{LCD} Terminal	2.5		V _{DD}	V
Operating Current	I _{DD}	V _{DD} Terminal			1	mA
Operating Current	I _{LCD}	V _{LCD} Terminal			2	mA
"H" Input Voltage	V _{IH}	T _{NH} Terminal	0.7V _{DD}		6.5	V
"L" Input Voltage	V _{IL}	T _{NH} Terminal	0		0.3V _{DD}	V
"H" Input Voltage	V _{IH}	CE, SCL, DN Terminals	0.8V _{DD}		6.5	V
"L" Input Voltage	V _{IL}	CE, SCL, DN Terminals	0		0.2V _{DD}	V
Oscillator Resistor	R _{osc}	OSC Terminal		51		kΩ
Oscillator Capacitor	C _{osc}	OSC Terminal		680		pF
Oscillator Frequency	f _{osc}	OSC Terminal	25	50	100	kHz
"H" Input Current	I _{IH}	V _{IN} =6.5V, CE, SCL, DN, T _{NH} Terminals			5	μA
"L" Input Current	I _{IL}	V _{IN} =0V, CE, SCL, DN, T _{NH} Terminals			5	μA
"H" Output Voltage	V _{OH}	I _O =-10μA SEG ₁ ~SEG ₅₃ Terminals	V _{LCD} -1.0			V
"L" Output Voltage	V _{OL}	I _O =10μA SEG ₁ ~SEG ₅₃ Terminals			1.0	V
"H" Output Voltage	V _{OH}	I _O =-100μA COM ₁ , COM ₂ Terminals	V _{LCD} -0.6			V
"L" Output Voltage	V _{OL}	I _O =100μA COM ₁ , COM ₂ Terminals			0.6	V
Middle Level Voltage	V _{MID}	I _O =±100μA, V _{LCD} =6.5V	2.65	3.25	3.85	V
		I _O =±100μA, V _{LCD} =3.0V	0.9	1.5	2.1	
Hysteresis Voltage	V _H	V _{DD} =5V, CE, SCL, DN Terminals	0.3			V

AC Characteristics

(Ta=-30~+85°C, VDD=6.5V, VSS=0V)

PARAMETER	SYMBOL	CONDITIONS	MIN	TYP	MAX	UNIT
"L" Clock Pulse Width	t _{WCLL}	SCL Terminal	0.25			μs
"H" Clock Pulse Width	t _{WCLH}	SCL Terminal	0.25			μs
Data Set-up Time	t _{DS}	SCL, DN Terminals	0.25			μs
Data Hold Time	t _{DH}	SCL, DN Terminals	0.25			μs
CE Set-up Time	t _{SCE}	CE, DN Terminals	1			μs
CE Hold Time (1)	t _{HDCE}	CE, DN Terminals	1			μs
CE Hold Time (2)	t _{HCLE}	CE, SCL Terminals	1.25			μs
Data Latch Delay Time	t _{DLDP}				1	μs
"L" Clock Enable Pulse Width	t _{WCEL}	CE Terminal	4			μs

• Input Timing Characteristics

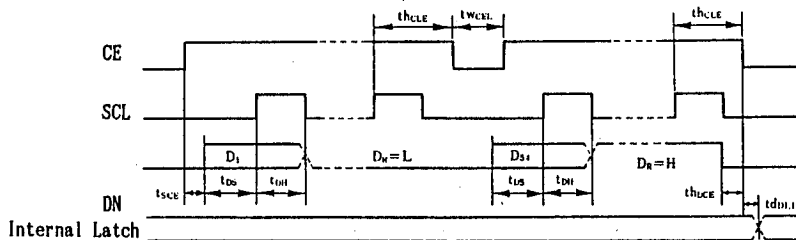
 The data is latched at D_R=H and falling edge of the CE signal condition.

• Output Timing Characteristics

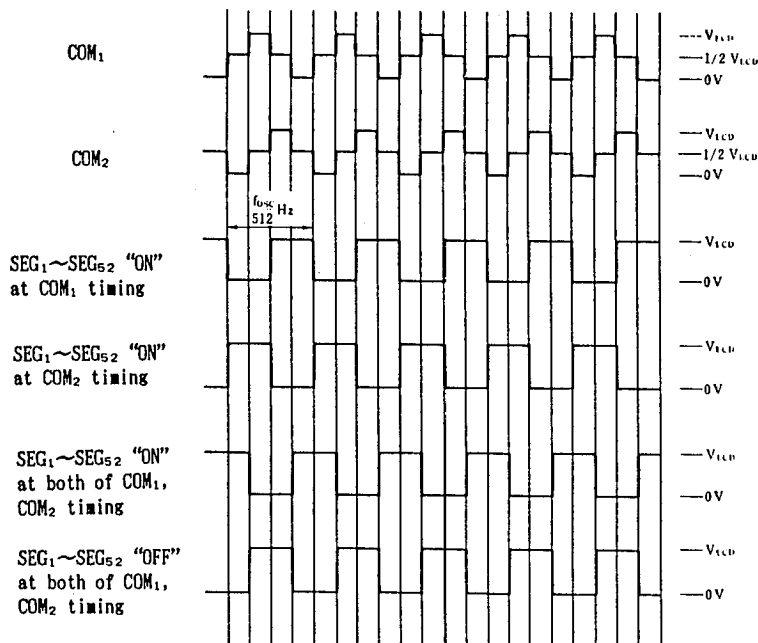

■ DISPLAY EXAMPLE

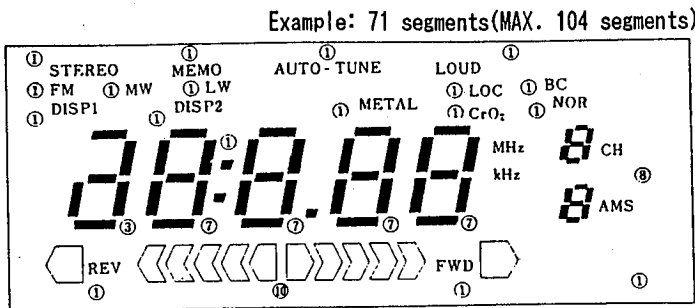

■ APPLICATION CIRCUITS

① In case of $V_{LCD} < V_{DD}$

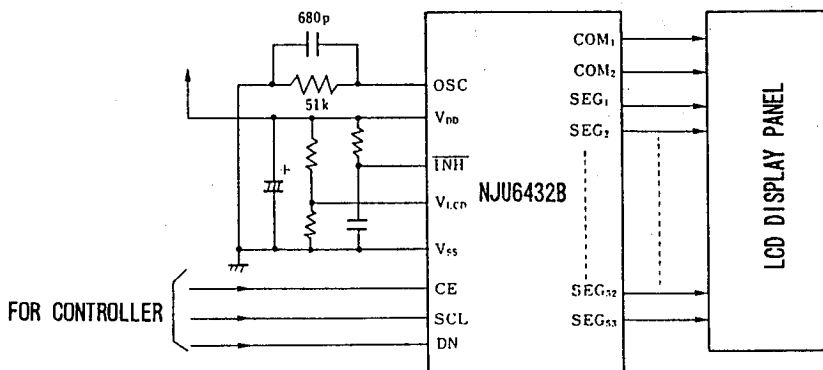

② In case of $V_{LCD} = V_{DD}$

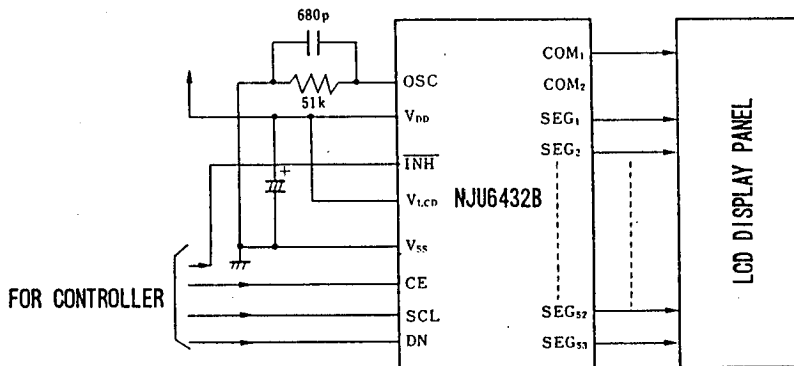

(Note) After rising edge of V_{DD} voltage, the display data is not guaranteed and which blinking is meaningless display. Therefore, keep TNH terminal to Low Level by the display data transferred is needed.

MEMO

[CAUTION]

The specifications on this databook are only given for information , without any guarantee as regards either mistakes or omissions. The application circuits in this databook are described only to show representative usages of the product and not intended for the guarantee or permission of any right including the industrial rights.

X-ON Electronics

Largest Supplier of Electrical and Electronic Components

Click to view similar products for [LCD Drivers](#) category:

Click to view products by [Nisshinbo](#) manufacturer:

Other Similar products are found below :

[LC75836WH-E](#) [CD4056BE](#) [LC75829PW-H](#) [LC75852W-E](#) [LC79430KNE-E](#) [LC79431KNE-E](#) [FAN7317BMX](#) [LC75839PW-H](#) [LC75884W-E](#) [LC75814VS-TLM-E](#) [MAX25520ATEC/V+](#) [MAX25520ATEB/VY+](#) [BU9795AFV-E2](#) [PCF8566T/1.118](#) [TPS65132A0YFFR](#) [BU9795AKV-E2](#) [34801000](#) [BU97510CKV-ME2](#) [BU97520AKV-ME2](#) [ICL7136CM44Z](#) [BL55070](#) [BL55066](#) [MAX1605ETT+T](#) [MAX16928BGUP/V+](#) [ICL7129ACPL+](#) [MAX131CMHD](#) [MAX138CMH+D](#) [MAX1491CAI+](#) [MAX1518BETJ+](#) [MAX1606EUA+](#) [MAX138CQH+TD](#) [MAX25520ATEB/V+](#) [MAX16929AGUI/V+](#) [MAX16929CGUI/V+](#) [MAX16929DGUI/V+](#) [MAX8570ELT+T](#) [MAX8570EUT+T](#) [MAX8571EUT+T](#) [MAX8575EUT+T](#) [MAX8795AGCJ/V+](#) [MAX138CPL+](#) [AY0438-I/L](#) [AY0438/L](#) [HV66PG-G](#) [HV881K7-G](#) [TC7106CKW](#) [TC7106CPL](#) [TC7116CPL](#) [TC7126CLW](#) [TC7126CPL](#)