

Piezo-sounder Driver with Multi-mode charge pump

■GENERAL DESCRIPTION

The NJU72501 is a switching driver with multi mode charge pump for piezo-sounder. It can drive outputs up to 18Vpp from 3V supply. For adjusting the piezoelectric sounder sound volume, the charge pump can operate in either of a 1x, 2x or 3x mode.

Because NJU72501 has the shutdown function, it is suitable for the battery application.

■PACKAGE OUTLINE



NJU72501MJE



NJU72501MG2



NJU72501V

■APPLICATION

Healthcare, Wrist Watches, Alarm Clocks, Handheld GPS devices, PDAs

■FEATURES

- Operating Voltage : 2.3 to 5.0V(1x/ 2x Mode), 2.3 to 3.4V(3x Mode)
- Consumption current (Active) : $I_{DS}=0.3\text{mA}$ typ. ($V_{IN}=3\text{V}$, $DIN=4\text{kHz}$, $C_{PIEZO}=15\text{nF}$, 1x Mode)
(Shutdown): $I_{DS}=1\mu\text{A}$ max. ($V_{IN}=3\text{V}$, $DIN=0\text{V}$)
- Multi-Mode Charge Pump (1x/2x/3x)
- Input Signal Detector & Shutdown Control
- Output Short-circuit Protection Circuit
- C-MOS Technology
- Package Outline : EQFN12-JE, EQFN16-G2, SSOP14
- Direct replacement to MAS6240

■BLOCK DIAGRAM

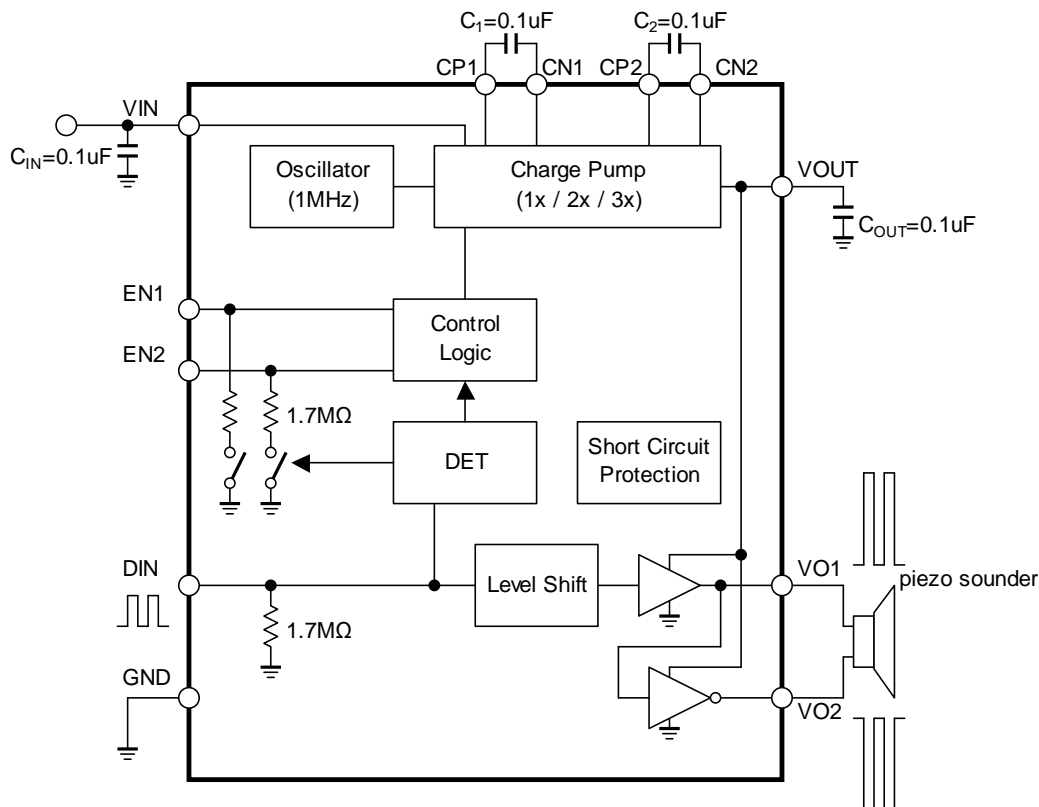

NJU72501

■ TERMINAL CONFIGURATION (EQFN12-JE)

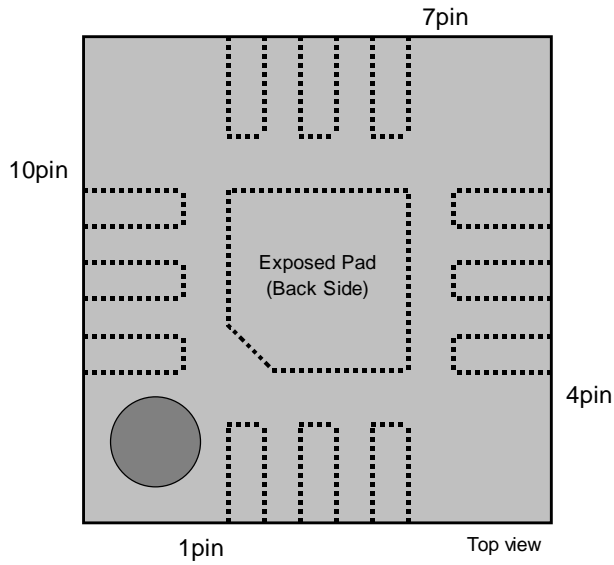

■ PIN DESCRIPTION

Pin No.	SYMBOL	FUNCTION
1	EN1	Step-up Mode Switch Terminal 1
2	EN2	Step-up Mode Switch Terminal 2
3	DIN	Input Terminal
4	CN1	Capacitor Connection Terminal
5	GND	GND Terminal
6	VO2	Output Terminal 2
7	VO1	Output Terminal 1
8	CN2	Capacitor Connection Terminal
9	CP1	Capacitor Connection Terminal
10	VOUT	Charge Pump Output Terminal
11	CP2	Capacitor Connection Terminal
12	VIN	Power Supply Terminal
Exp Pad	Exposed Pad	Exposed Pad connected to GND or left floating

■ TERMINAL CONFIGURATION (EQFN16-G2)

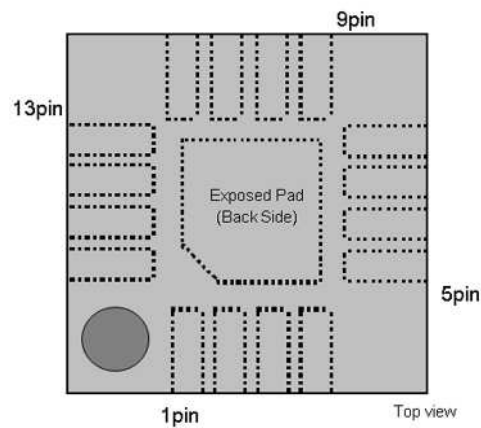

■ PIN DESCRIPTION

Pin No.	SYMBOL	FUNCTION
1	NC	
2	EN1	Step-up Mode Switch Terminal 1
3	EN2	Step-up Mode Switch Terminal 2
4	DIN	Input Terminal
5	NC	
6	CN1	Capacitor Connection Terminal
7	GND	GND Terminal
8	VO2	Output Terminal 2
9	VO1	Output Terminal 1
10	CN2	Capacitor Connection Terminal
11	CP1	Capacitor Connection Terminal
12	NC	
13	VOOUT	Charge Pump Output Terminal
14	CP2	Capacitor Connection Terminal
15	VIN	Power Supply Terminal
16	NC	
Exp Pad	Exposed Pad	Exposed Pad connected to GND or left floating

NJU72501

■ TERMINAL CONFIGURATION (SSOP14)

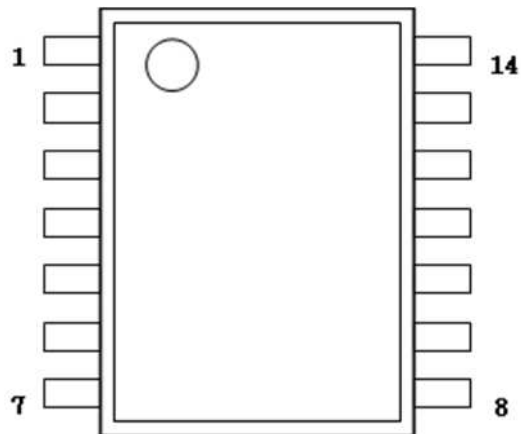

Pin No.	SYMBOL	FUNCTION
1	EN2	Step-up Mode Switch Terminal 2
2	DIN	Input Terminal
3	CN1	Capacitor Connection Terminal
4	GND	GND Terminal
5	VO2	Output Terminal 2
6	VO1	Output Terminal 1
7	CN2	Capacitor Connection Terminal
8	CP1	Capacitor Connection Terminal
9	NC	
10	VOUT	Charge Pump Output Terminal
11	CP2	Capacitor Connection Terminal
12	VIN	Power Supply Terminal
13	NC	
14	EN1	Step-up Mode Switch Terminal 1

■ABSOLUTE MAXIMUM RATINGS

PARAMETER	SYMBOL	RATING	UNIT
Supply Voltage	V_{IN}	5.5V 1xMode, 2xMode 4.0V 3xMode	V
Input Voltage	V_{DIN}	-0.3 to $V_{IN}+0.3$	V
Power Dissipation	P_D	480 ^{*1)} / 1300 ^{*2)} (EQFN12) 400 ^{*1)} / 1000 ^{*2)} (EQFN16) 440 ^{*3)} / 550 ^{*4)} (SSOP14)	mW
Operating Temperature	T_{opr}	-40 to +85	°C
Storage Temperature	T_{stg}	-40 to +125	°C

(Note) ^{*1)} EIA/JEDEC STANDARD Test board (76.2 x 114.3 x 1.6mm, 2layers, FR-4) mounting. The PAD connecting to GND in the center part on the back.

^{*2)} EIA/JEDEC STANDARD Test board (76.2 x 114.3 x 1.6mm, 4layers, FR-4) mounting. The PAD connecting to GND in the center part on the back. Applying a thermal via hole mounted.

^{*3)} EIA/JEDEC STANDARD Test board (76.2 x 114.3 x 1.6mm, 2layers, FR-4) mounting.

^{*4)} EIA/JEDEC STANDARD Test board (76.2 x 114.3 x 1.6mm, 4layers, FR-4) mounting.

■RECOMMENDED OPEARATING CONDITION ($T_a=25^{\circ}C$)

PARAMETER	SYMBOL	CONDITIONS	MIN	TYP	MAX	UNIT
Operating Voltage	V_{IN}	1x Mode, 2x Mode	2.3	3.0	5.0	V
		1x Mode, 2x Mode, 3x Mode	2.3	3.0	3.4	

■ELECTRICAL CHARACTERISTICS

($T_a=25^{\circ}C, V_{IN}=3V, C_1=100nF, C_2=100nF, C_{OUT}=100nF, C_{PIEZO}=15nF, DIN=4kHz$)

PARAMETER	SYMBOL	CONDITIONS	MIN	TYP	MAX	UNIT
Output Voltage	V_{OUT1}	1x Mode	2.8	-	3	V
	V_{OUT2}	2x Mode	5.2	-	6	V
	V_{OUT3}	3x Mode	7.2	-	9	V
Operating Current 1	I_{DD11}	1x Mode $C_{PIEZO}=\text{no load}$	-	140	240	μA
	I_{DD12}	2x Mode $C_{PIEZO}=\text{no load}$	-	720	1200	μA
	I_{DD13}	3x Mode $C_{PIEZO}=\text{no load}$	-	2500	4500	μA
Operating Current 2	I_{DD21}	1x Mode Single ended application	-	0.3	-	mA
	I_{DD22}	2x Mode Single ended application	-	1.4	-	mA
	I_{DD23}	3x Mode Single ended application	-	3.9	-	mA
Operating Current 3	I_{DD31}	1x Mode Differential application	-	0.9	-	mA
	I_{DD32}	2x Mode Differential application	-	3.6	-	mA
	I_{DD33}	3x Mode Differential application	-	7.9	-	mA
Consumption Current at Shutdown	I_{SD}	$DIN=0V, ^{(*1)}$	-	-	1	μA
Input Frequency	F_{IN}	Rectangular pulse	0.2	4	8	kHz
Oscillating Frequency	F_{OSC}		0.6	1	1.8	MHz

(*1: When 50msec or more maintains DIN, EN1, EN2 in 0

NJU72501

■ELECTRICAL CHARACTERISTICS

(Ta=25°C, V_{IN}=3V, C₁=100nF, C₂=100nF, C_{OUT}=100nF, C_{PIEZO}=15nF, DIN=4kHz)

PARAMETER	SYMBOL	CONDITIONS	MIN	TYP	MAX	UNIT
VOUT Start Delay Time	T _{ON1}	1x Mode From DIN signal High to 90% VOUT steady state	-	30	100	μs
	T _{ON2}	2x Mode From DIN signal High to 90% VOUT steady state	-	90	200	μs
	T _{ON3}	3x Mode From DIN signal High to 90% VOUT steady state	-	180	350	μs
Shutdown Delay Time	T _{OFF}	DIN=H -> L	21	42	84	Ms
Output Short-circuit Protection Limitation Current	I _{SC}		20	40	60	mA

■CONTROL PART CHARACTERISTICS

Ta=25°C, V_{IN}=3V

PARAMETER	SYMBOL	CONDITIONS	MIN	TYP	MAX	UNIT
Control Terminal Voltage H	V _{IH}	EN1 , EN2 , DIN pins	0.8*V _{IN}	-	V _{IN}	V
Control Terminal Voltage L	V _{IL}	EN1 , EN2 , DIN pins	0	-	0.2*V _{IN}	V
Control Terminal Current 1	I _{IH1}	DIN=3V	-	1.7	3.4	μA
Control Terminal Current 2	I _{IH2}	V _{EN1} , V _{EN2} =3V , DIN=3V	-	1.7	3.4	μA
Control Terminal Current 3	I _{IH3}	V _{EN1} , V _{EN2} =3V , DIN=0V	-	-	1	μA

■CHARGE PUMP MODE SETTING

DIN	EN1	EN2	Charge Pump Mode
0	-	-	Shut Down Mode
1	0	0	Shut Down Mode
1	0	1	1x Mode
1	1	0	2x Mode
1	1	1	3x Mode

■TIMING CHART

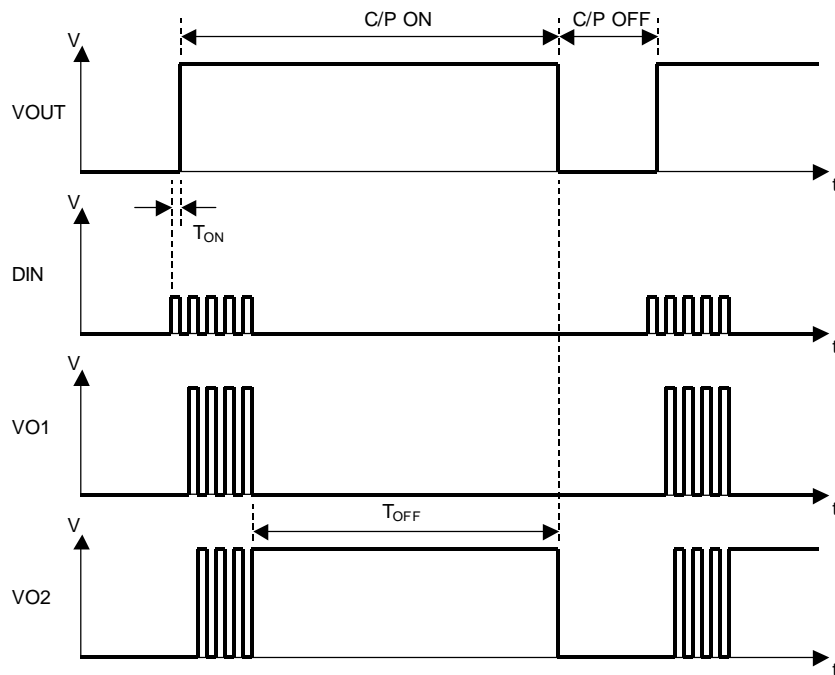

NJU72501

APPLICATION CIRCUIT 1 (Single-end output)

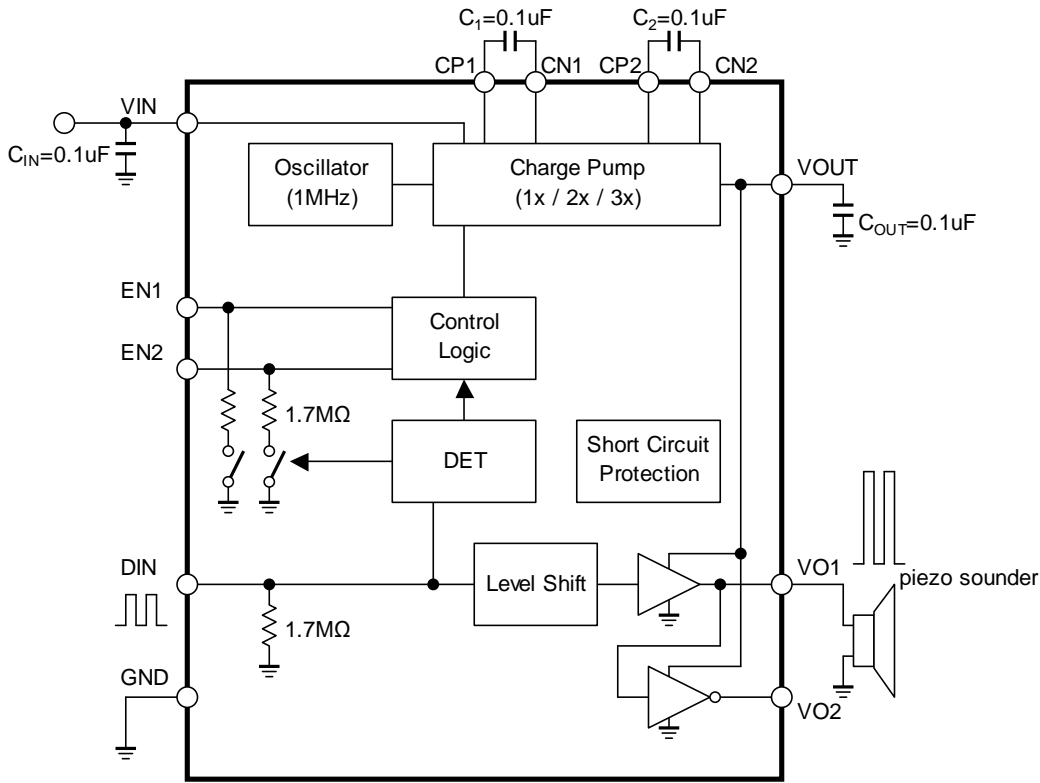

APPLICATION CIRCUIT 2 (Differential output)

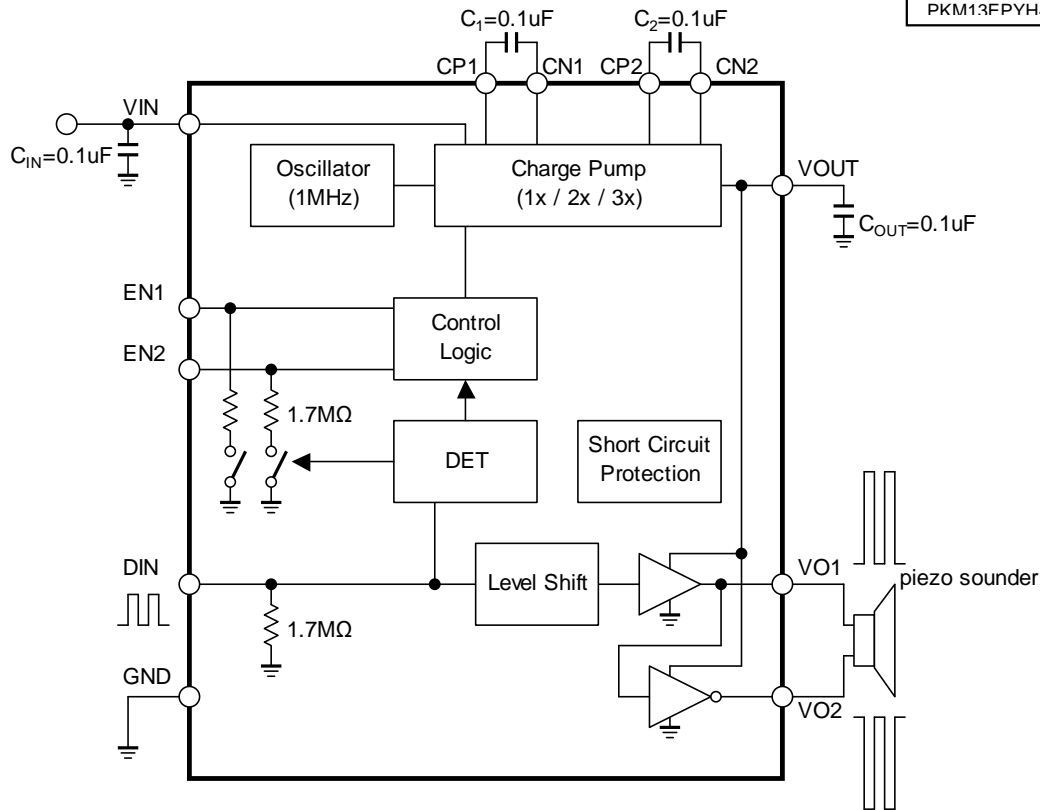

Recommended Parts
 Piezo-sounder/ Piezo-buzzer
 PKLCS1212E2400-R1(muRata)
 PKLCS1212E4001-R1(muRata)
 PKM13FPYH4000-A0(muRata)

■PACKAGE INFORMATION (EQFN12-JE)

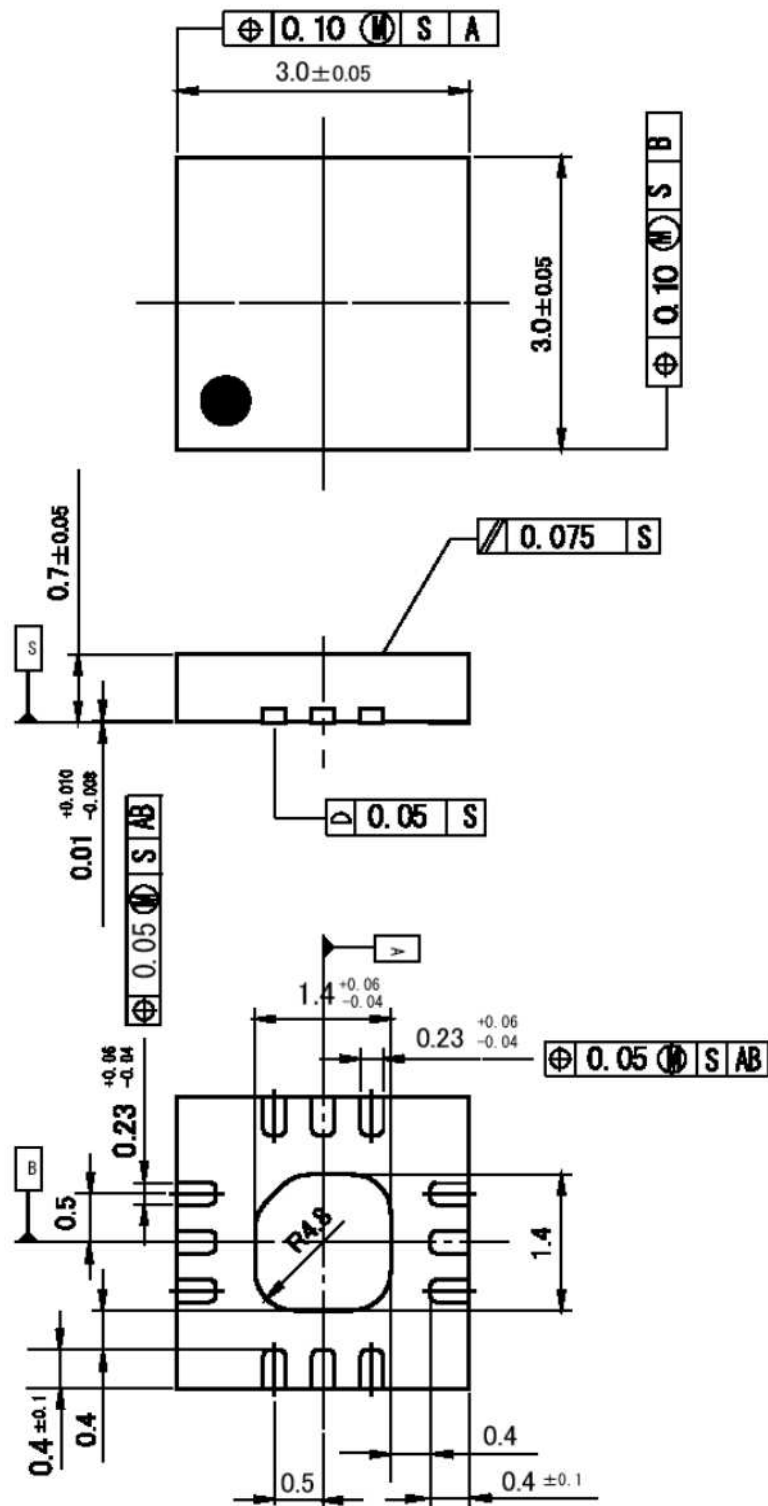

■PACKAGE INFORMATION (SSOP14)

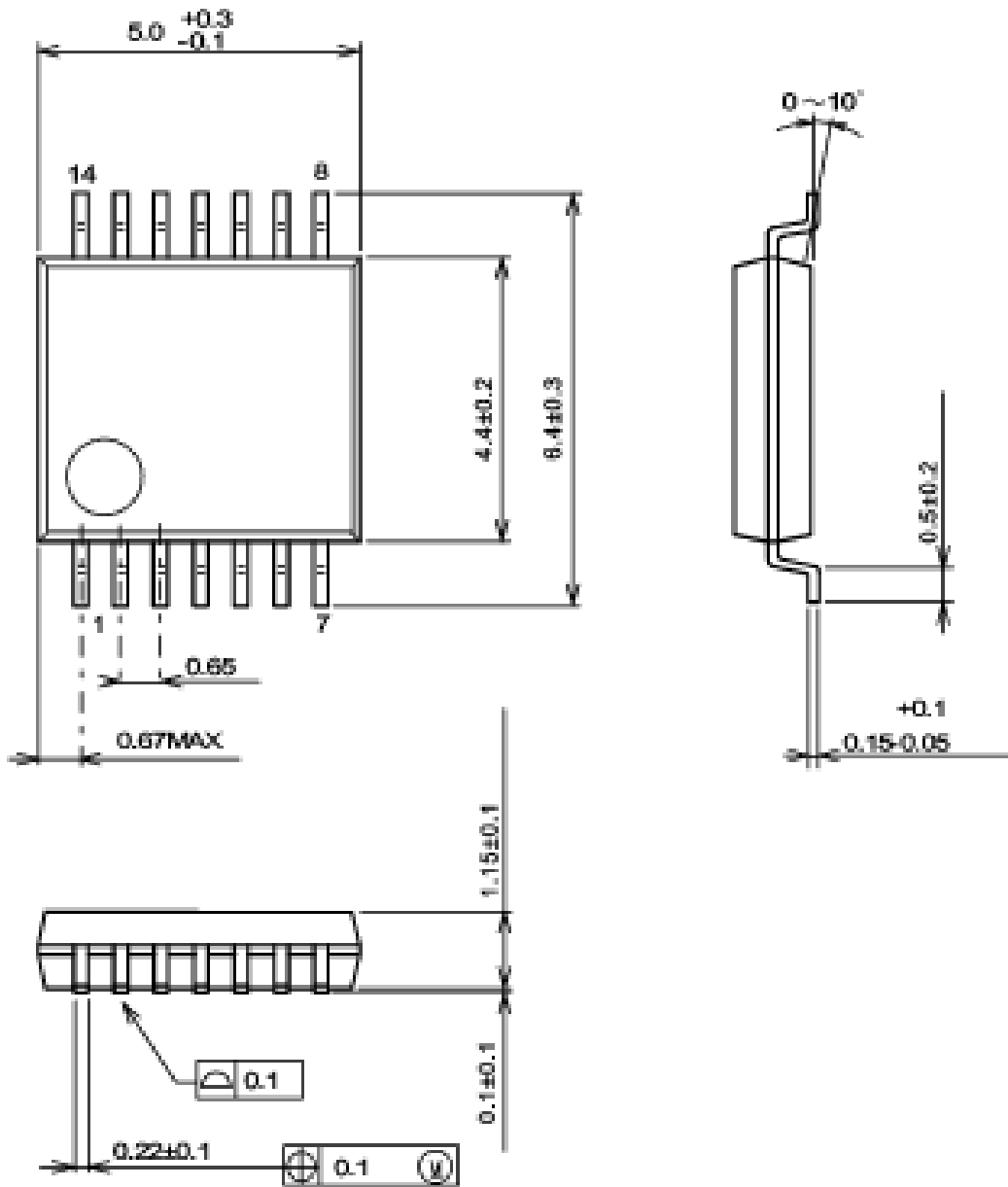

[CAUTION]

The specifications on this databook are only given for information, without any guarantee as regards either mistakes or omissions. The application circuits in this databook are described only to show representative usages of the product and not intended for the guarantee or permission of any right including the industrial rights.

X-ON Electronics

Largest Supplier of Electrical and Electronic Components

Click to view similar products for [Audio Amplifiers](#) category:

Click to view products by [Nisshinbo](#) manufacturer:

Other Similar products are found below :

[LV47002P-E](#) [NCP2811AFCT1G](#) [NCP2890AFCT2G](#) [SSM2377ACBZ-R7](#) [IS31AP4915A-QFLS2-TR](#) [NCP2820FCT2G](#) [TDA1591T](#)
[TDA7563AH](#) [SSM2529ACBZ-R7](#) [MAX9890AETA+T](#) [TS2012EIJT](#) [NCP2809BMUTXG](#) [NJW1157BFC2](#) [SSM2375CBZ-REEL7](#)
[IS31AP4996-GRLS2-TR](#) [STPA002OD-4WX](#) [NCP2823BFCT1G](#) [MAX9717DETA+T](#) [MAX9717CETA+T](#) [MAX9724AEBC+TG45](#)
[LA4450L-E](#) [IS31AP2036A-CLS2-TR](#) [MAX9723DEBE+T](#) [TDA7563ASMTR](#) [AS3561-DWLT](#) [SSM2517CBZ-R7](#) [MP1720DH-12-LF-P](#)
[SABRE9601K](#) [THAT1646W16-U](#) [MAX98396EWB+](#) [PAM8965ZLA40-13](#) [BD37532FV-E2](#) [BD5638NUX-TR](#) [BD37512FS-E2](#) [BD37543FS-](#)
[E2](#) [BD3814FV-E2](#) [TPA3140D2PWPR](#) [TS2007EIJT](#) [IS31AP2005-DLS2-TR](#) [SSM2518CPZ-R7](#) [AS3410-EQFP-500](#) [FDA4100LV](#)
[MAX98306ETD+T](#) [TS4994EIJT](#) [NCP2820FCT1G](#) [NCP2823AFCT2G](#) [NCS2211MNTXG](#) [CPA2233CQ16-A1](#) [OPA1604AIPWR](#)
[OPA1612AQDRQ1](#)