

## 7-INPUT / 3-OUTPUT DUAL ANALOG SWITCH

### ■ GENERAL DESCRIPTION

The **NJU72750A** is a 7-input / 3-output dual analog switch. Functions are controlled via two-wired serial bus. A-channel switches and B-channel switches are controlled independently.

The **NJU72750A** is well-suited for multi-channel audio systems such as AV amplifiers, DVD receivers and others.

### ■ PACKAGE OUTLINE

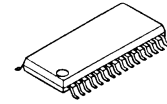

**NJU72750AV**

### ■ FEATURES

ℓ Operating Voltage

ℓ 2-wired Serial BUS Control

ℓ Selectable 2-Chip Address

ℓ ON Resistance

ℓ Low Distortion

ℓ CMOS Technology

ℓ Package Outline

Dual power supply:  $\pm 4.5$  to  $\pm 7.5$ V

Single power supply: +9.0 to +15.0V

Available for using four chips on same serial bus line

15 $\Omega$  typ.

0.0004% typ. ( $V_{IN}=1V_{rms}$ )

SSOP32

### ■ BLOCK DIAGRAM

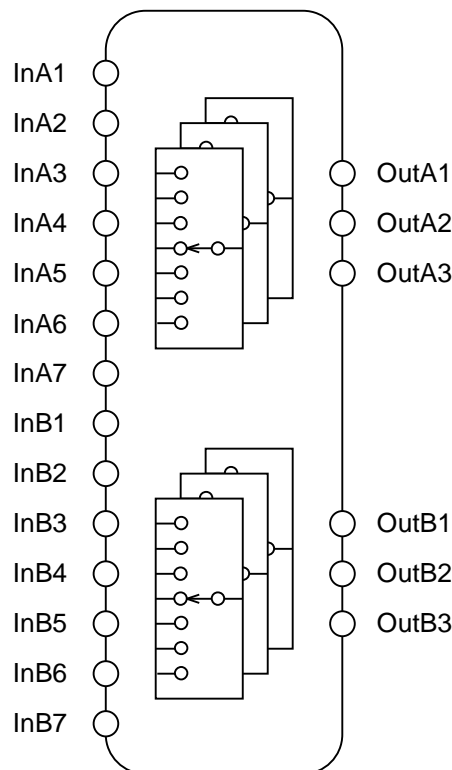

# NJU72750A

## ■ PIN CONFIGURATION

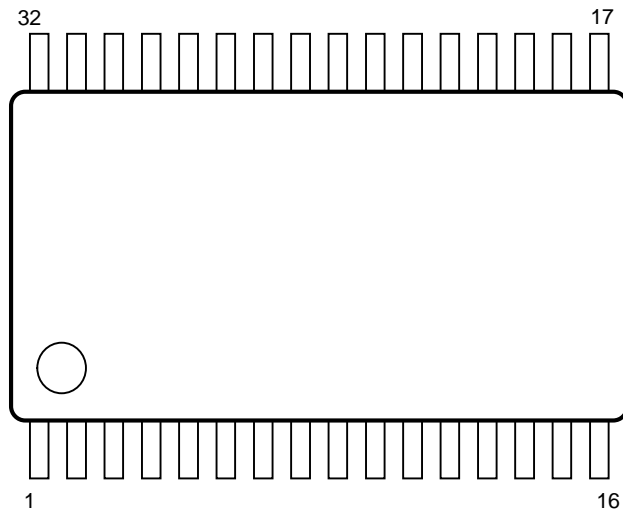

No.	Symbol	Function		Symbol	Function
1	V+	Power supply (+)	17	DATA	Control data signal Input terminal
2	InA1	Ach Input terminal 1	18	CLOCK	Clock signal Input terminal
3	InB1	Bch Input terminal 1	19	NC	No connect
4	InA2	Ach Input terminal 2	20	NC	No connect
5	InB2	Bch Input terminal 2	21	OutB3	Bch Output terminal 3
6	InA3	Ach Input terminal 3	22	OutA3	Ach Output terminal 3
7	InB3	Bch Input terminal 3	23	REF_B	Bch Reference Voltage terminal
8	InA4	Ach Input terminal 4	24	OutB2	Bch Output terminal 2
9	InB4	Bch Input terminal 4	25	OutA2	Ach Output terminal 2
10	InA5	Ach Input terminal 5	26	REF_A	Ach Reference Voltage terminal
11	InB5	Bch Input terminal 5	27	OutB1	Bch Output terminal 1
12	InA6	Ach Input terminal 6	28	OutA1	Ach Output terminal 1
13	InB6	Bch Input terminal 6	29	NC	No connect
14	InA7	Ach Input terminal 7	30	ADR0	Chip address setting terminal 0
15	InB7	Bch Input terminal 7	31	ADR1	Chip address setting terminal 1
16	REF	Digital block reference voltage terminal	32	V-	Power supply (-)

## ■ ABSOLUTE MAXIMUM RATING (Ta=25°C)

PARAMETER	SYMBOL	RATING	UNIT
Supply Voltage	V <sup>+</sup> /V <sup>-</sup>	±8	V
Maximum Input Voltage	V <sub>IM</sub>	V <sup>+</sup> /V <sup>-</sup>	V
Power Dissipation	P <sub>D</sub>	950 NOTE: EIA/JEDEC STANDARD Test board (76.2x114.3x1.6mm, 2layer, FR-4) mounting	mW
Operating Temperature Range	Topr	-40 to +85	°C
Storage Temperature Range	Tstg	-40 to +125	°C
Load Resistance	R <sub>L</sub>	>1	kΩ

## ■ RECOMMENDED OPERATING VOLTAGE RANGE (Ta=25°C unless otherwise specified)

PARAMETER	SYMBOL	TEST CONDITION	MIN.	TYP.	MAX.	UNIT
Operating Voltage Range	V <sup>+</sup> /V <sup>-</sup>		±4.5	±7.0	±7.5	V

## ■ ELECTRICAL CHARACTERISTICS (Ta=25°C, V<sup>+</sup>/V<sup>-</sup>=±7, R<sub>L</sub>=20kΩ unless otherwise specified)

### ◆DC CHARACTERISTICS

PARAMETER	SYMBOL	TEST CONDITION	MIN.	TYP.	MAX.	UNIT
Supply Current1	I <sub>DD</sub>	No Signal (V <sup>+</sup> ), No Load	-	0.4	1	mA
Supply Current2	I <sub>SS</sub>	No Signal (V <sup>-</sup> ), No Load	-	0.4	1	mA
Switch ON Resistance1	R <sub>ON1</sub>	Switch A11 to A73, B11 to B73, I <sub>O</sub> =3mA	-	15	40	Ω
Switch ON Resistance2	R <sub>ON2</sub>	L-Imp A1 to A3, B1 to B3, I <sub>O</sub> =300μA	-	0.4	1	kΩ

### ◆AC CHARACTERISTICS

PARAMETER	SYMBOL	TEST CONDITION	MIN.	TYP.	MAX.	UNIT
Total Harmonic Distortion	T.H.D.	f=1kHz, V <sub>IN</sub> =1Vrms, BW=400Hz to 30kHz	-	0.0004	-	%
Cross Talk	CT	R <sub>g</sub> =0Ω, f=1kHz, V <sub>IN</sub> =2Vrms, Bandpass	-	-110	-	dB
Channel Separation	CS	R <sub>g</sub> =0Ω, f=1kHz, V <sub>IN</sub> =2Vrms, Bandpass	-	-110	-	dB

## ■ LOGIC CONTROL CHARACTERISTICS (Ta=25°C unless otherwise specified)

### ◆LOGIC CONTROL TERMINAL CHARACTERISTICS

PARAMETER	SYMBOL	TEST CONDITION	MIN.	TYP.	MAX.	UNIT
High Level Input Voltage 1	V <sub>IH1</sub>	ADR0, ADR1 terminal	2.5	-	V <sup>+</sup>	V
Low Level Input Voltage 1	V <sub>IL1</sub>	ADR0, ADR1 terminal	0	-	0.8	V
High Level Input Voltage 2	V <sub>IH2</sub>	DATA, CLOCK terminal	2.5	-	5.5	V
Low Level Input Voltage 2	V <sub>IL2</sub>	DATA, CLOCK terminal	0	-	0.8	V

# NJU72750A

## ■ TERMINAL DESCRIPTION

Terminal	SYMBOL	FUNCTION	EQUIVALENT CIRCUIT	VOLTAGE
2 3 4 5 6 7 8 9 10 11 12 13 14 15 23 26	InA1 InB1 InA2 InB2 InA3 InB3 InA4 InB4 InA5 InB5 InA6 InB6 InA7 InB7 REF_B REF_A	Ach Input 1 Bch Input 1 Ach Input 2 Bch Input 2 Ach Input 3 Bch Input 3 Ach Input 4 Bch Input 4 Ach Input 5 Bch Input 5 Ach Input 6 Bch Input 6 Ach Input 7 Bch Input 7 Bch Reference Ach Reference		-
16	REF	Digital Reference		-
17 18	DATA CLOCK	Control data Input Clock signal Input		-
21 22 24 25 27 28	OutB3 OutA3 OutB2 OutA2 OutB1 OutA1	Bch Output 3 Ach Output 3 Bch Output 2 Ach Output 2 Bch Output 1 Ach Output 1		-

Terminal	SYMBOL	FUNCTION	EQUIVALENT CIRCUIT	VOLTAGE
30 31	ADR0 ADR1	Chip address 0 Chip address 1		-

# NJU72750A

## ■ TEST CIRCUIT

◆  $I_{DD}/I_{SS}$

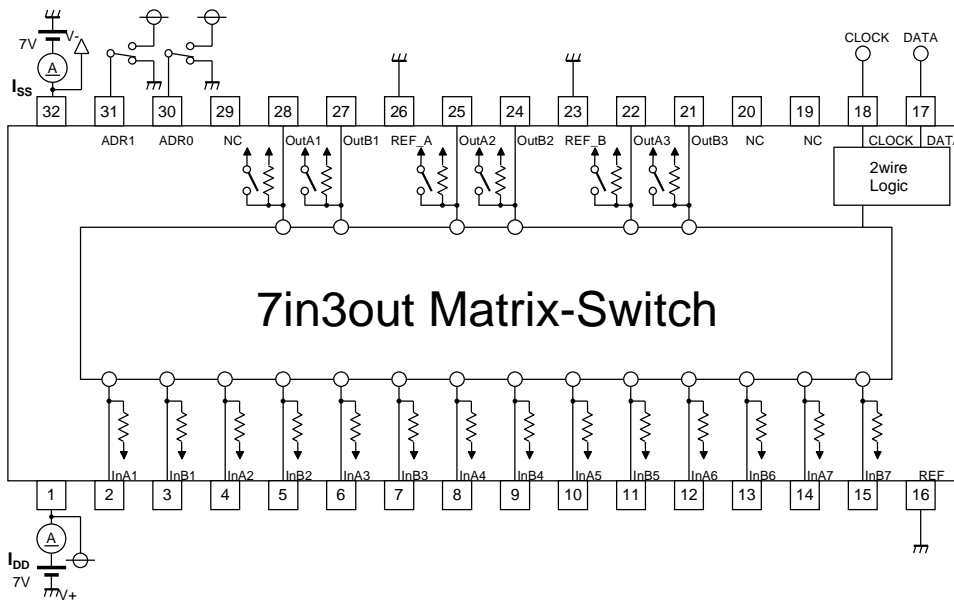

◆  $R_{ON}$

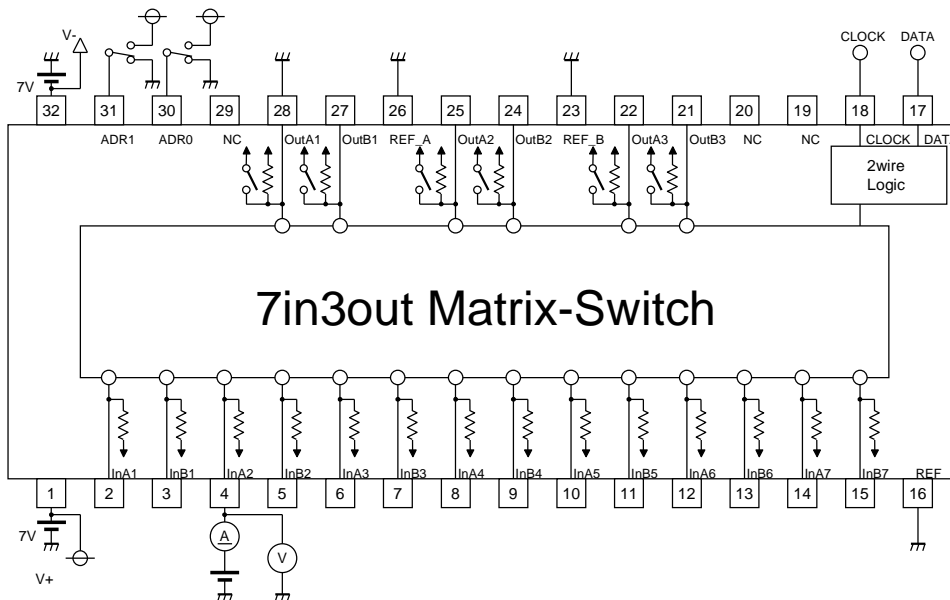

## ◆THD

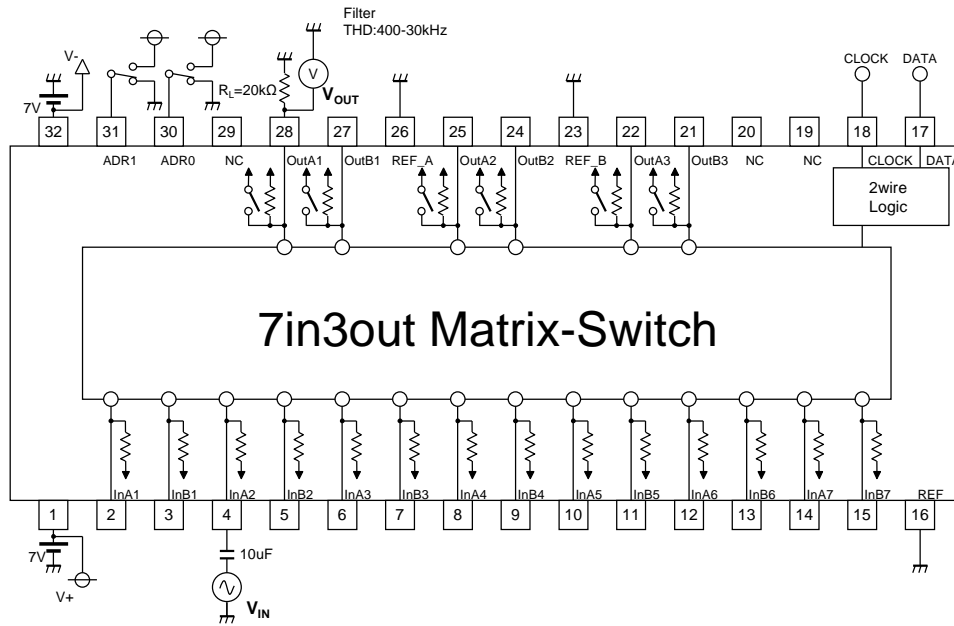

## ◆CT/CS

**CT** Ex) A11=ON, A21=OFF, Input=InA2 -> Measure=OutA1  
 B12=ON, B22=OFF, Input=InB2 -> Measure=OutB2

**CS** Ex) A11=ON, B11=ON, Input=InB1 -> Measure=OutA1  
 B11=ON, A31=ON, Input=InA3 -> Measure=OutB1

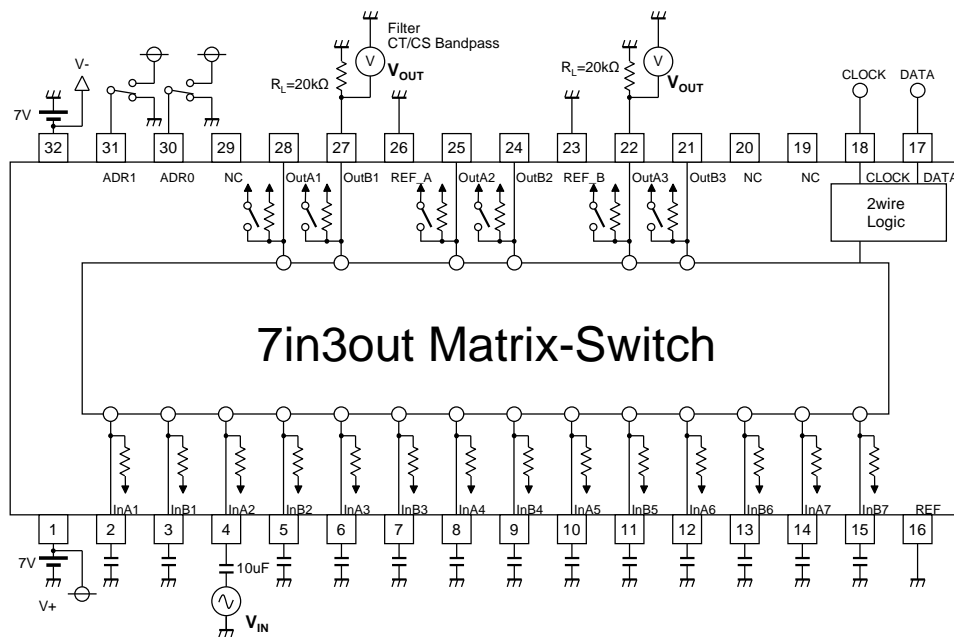

# NJU72750A

## ■ APPLICATION CIRCUIT 1 (Dual power supply operation)

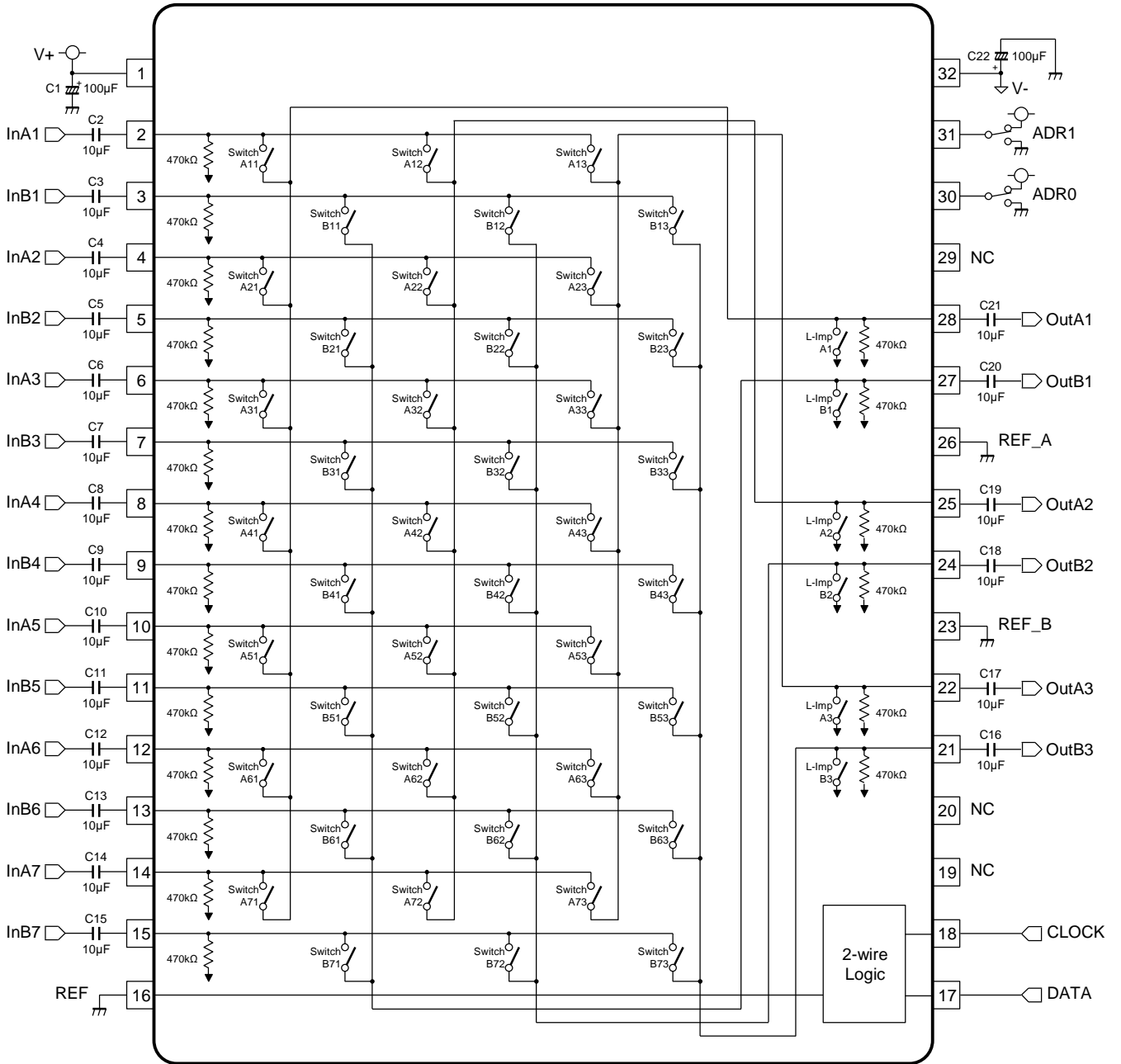



## APPLICATION CIRCUIT 2 (Single power supply operation)

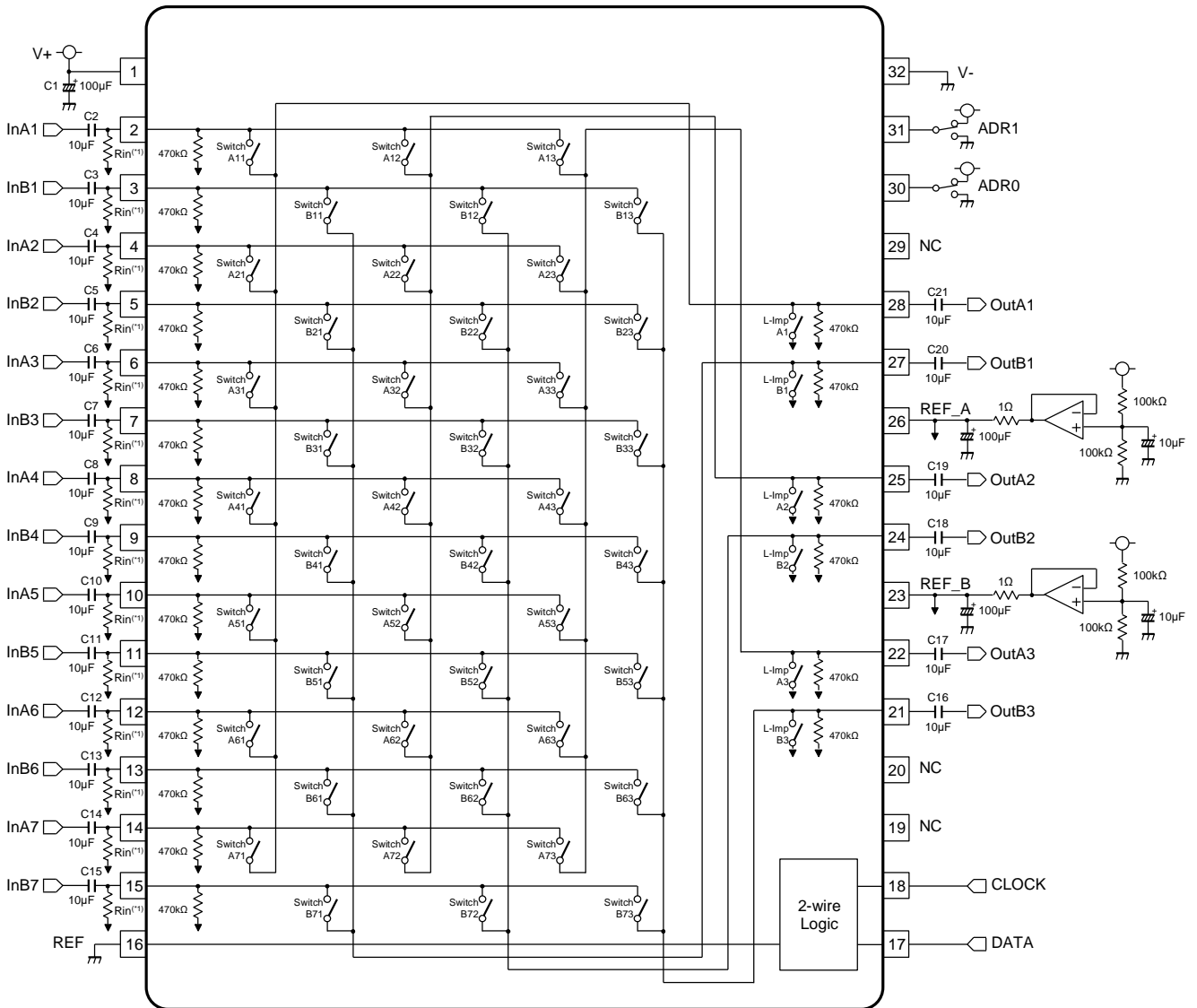

(\*) When power supply is turned on, please add external resistors "Rin" in the case that wish to shorten the time to stabilize reference voltage.

# NJU72750A

## ■TIMING ON 2-wire BUS (DATA, CLOCK)

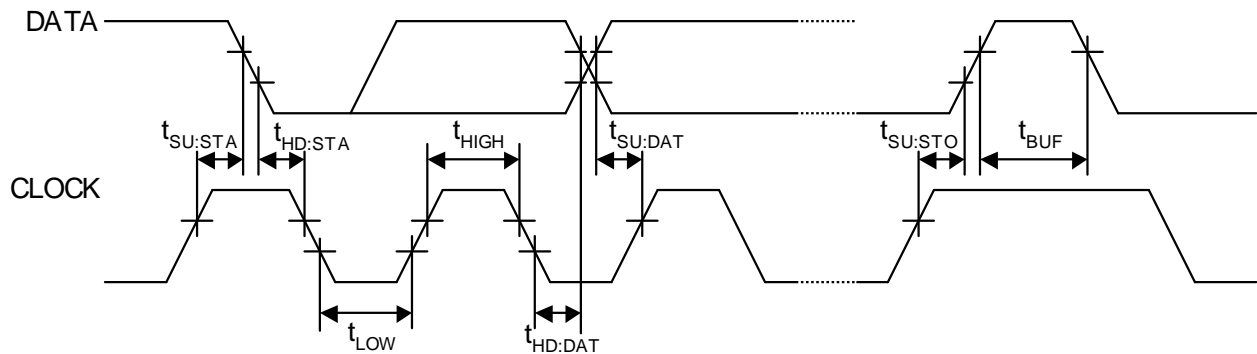

## ■CHARACTERISTICS OF I/O STAGES FOR 2-wire BUS (DATA, CLOCK)

PARAMETER	SYMBOL	MIN.	TYP.	MAX.	UNIT
$t_{HD\_STA}$	Hold time (repeated) START condition.	4	-	-	$\mu\text{s}$
$t_{LOW}$	Low period of the CLOCK clock	2	-	-	$\mu\text{s}$
$t_{HIGH}$	High period of the CLOCK clock	2	-	-	$\mu\text{s}$
$t_{SU\_STA}$	Set-up time for a repeated START condition	2	-	-	$\mu\text{s}$
$t_{HD\_DAT}$	Data hold time	1	-	-	$\mu\text{s}$
$t_{SU\_DAT}$	Data set-up time	1	-	-	$\mu\text{s}$
$t_{SU\_STO}$	Set-up time for STOP condition	2	-	-	$\mu\text{s}$
$t_{BUF}$	Bus free time between a STOP and START condition	4	-	-	$\mu\text{s}$

## ■RECOMMENDED POWER-UP SEQUENCE

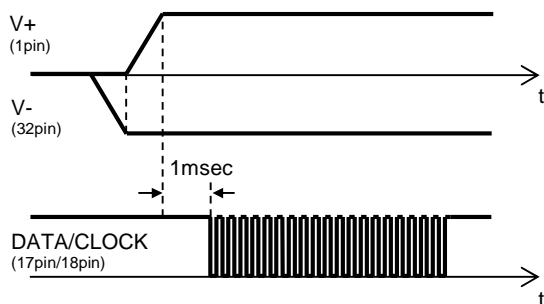

## ■ DEFINITION OF 2-wire REGISTER

### ◆ 2-wire BUS FORMAT

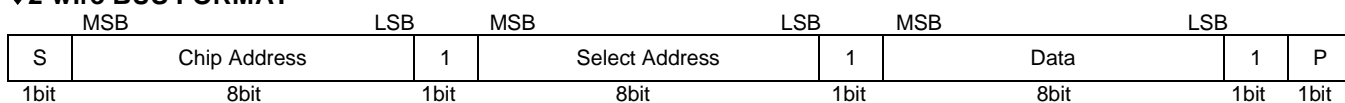

S: Starting Term

P: Ending Term

### ◆ Chip Address

MSB					LSB			
1	0	0	1	1	ADR1	ADR0	0	
1	0	0	1	1	0	0	0	98H (ADR1 = Low, ADR0 = Low)
1	0	0	1	1	0	1	0	9AH (ADR1 = Low, ADR0 = High)
1	0	0	1	1	1	0	0	9CH (ADR1 = High, ADR0 = Low)
1	0	0	1	1	1	1	0	9EH (ADR1 = High, ADR0 = High)

### ◆ Select Address

The select address sets each function.

The auto increment function cycles the select address as follows.

00H→01H→02H→03H→04H→05H→00H

Select Address	MSB							LSB
	D7	D6	D5	D4	D3	D2	D1	D0
00H	A71	A61	A51	A41	A31	A21	A11	L-Imp A1
01H	B71	B61	B51	B41	B31	B21	B11	L-Imp B1
02H	A72	A62	A52	A42	A32	A22	A12	L-Imp A2
03H	B72	B62	B52	B42	B32	B22	B12	L-Imp B2
04H	A73	A63	A53	A43	A33	A23	A13	L-Imp A3
05H	B73	B63	B53	B43	B33	B23	B13	L-Imp B3

# NJU72750A

---

## ■ INITIAL CONDITION

Select Address	Data							
	D7	D6	D5	D4	D3	D2	D1	D0
00H	0	0	0	0	0	0	0	0
01H	0	0	0	0	0	0	0	0
02H	0	0	0	0	0	0	0	0
03H	0	0	0	0	0	0	0	0
04H	0	0	0	0	0	0	0	0
05H	0	0	0	0	0	0	0	0

Note.) This product starts up by MUTE setting in power "ON". Use it after removing MUTE of each setting.  
If any audio signal is inputted in input signal terminal before power "ON", it may cause initial condition abnormality.  
In conditions of use such as the above, it prevents that abnormality by setting MUTE before power "OFF"

## ■ DEFINITION OF RESISTOR

**Switch(A11 to A73, B11 to B73):** Select "Switch ON" or "Switch OFF". Each switch is controlled independently.

**L-Imp(A1 to A3, B1 to B3):** Select "Switch ON" or "Switch OFF". Each switch is controlled independently.

It is the switch lowers the impedance of the output terminal.

Select Address	MSB				LSB				L-Imp
	D7	D6	D5	D4	D3	D2	D1	D0	
00H	A71	A61	A51	A41	A31	A21	A11	L-Imp A1	
01H	B71	B61	B51	B41	B31	B21	B11	L-Imp B1	
02H	A72	A62	A52	A42	A32	A22	A12	L-Imp A2	
03H	B72	B62	B52	B42	B32	B22	B12	L-Imp B2	
04H	A73	A63	A53	A43	A33	A23	A13	L-Imp A3	
05H	B73	B63	B53	B43	B33	B23	B13	L-Imp B3	

Data naming rule

Ex.) A11

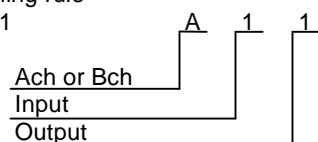

< Switch Setting >

Data	Setting
D7 ~ D0	
0	OFF <sup>(c)</sup>
1	ON

<sup>(c)</sup>Initial Setting

# NJU72750A

## ■ TYPICAL CHARACTERISTICS

**Supply Current 1 vs Supply Voltage**  
No signal

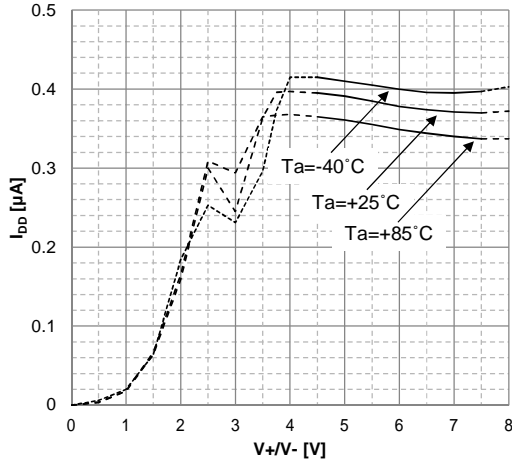

**Supply Current 2 vs Supply Voltage**  
No signal

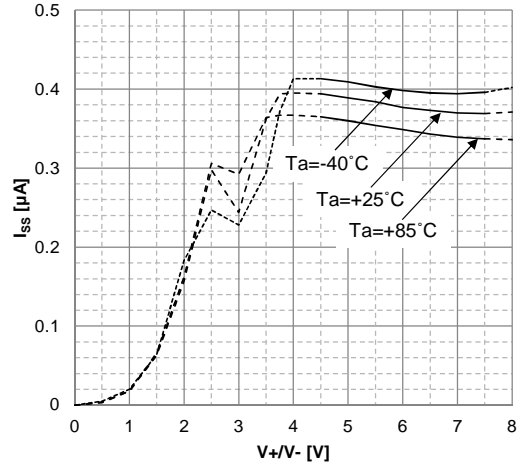

**Switch ON Resistance vs Supply Voltage**  
 $I_O=3mA$

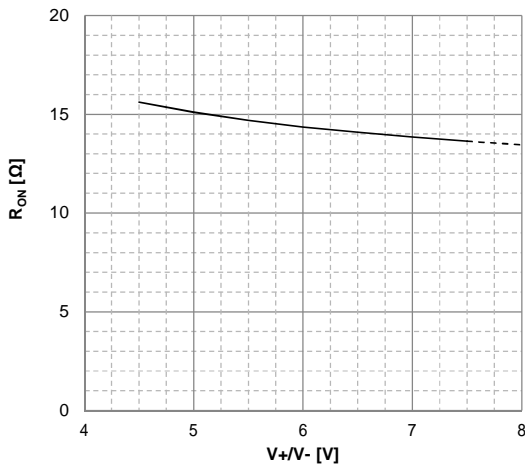

**Switch ON Resistance vs Temperature**  
 $I_O=3mA$

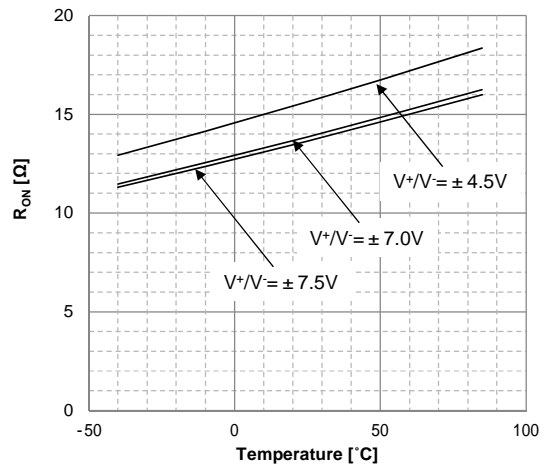

**THD+N vs Input Voltage**  
 $f=1kHz, R_L=20k\Omega, BW: 400-30kHz$

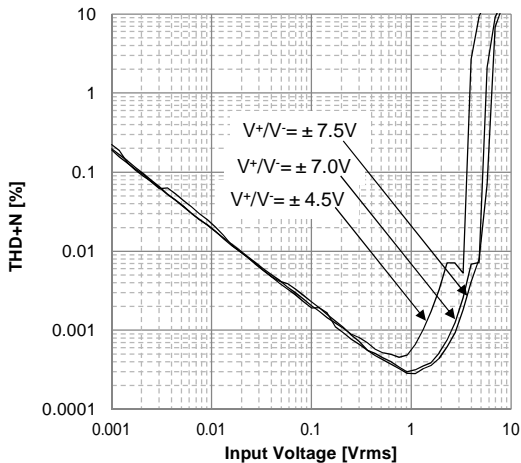

**THD+N vs Input Voltage**  
 $V+/V- = \pm 7V, f=1kHz, BW: 400-30kHz,$

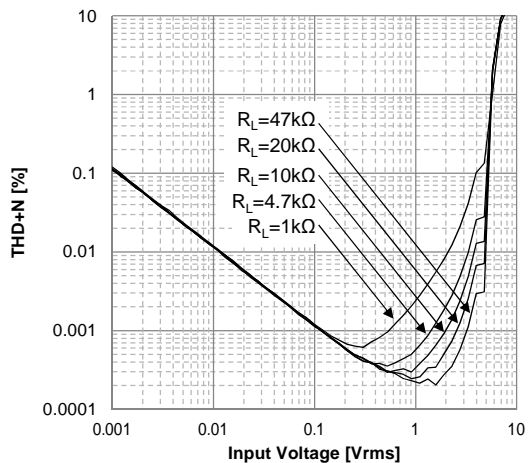

## ■ TYPICAL CHARACTERISTICS

### THD+N vs Input Voltage

$V^+/V^- = \pm 7V$ ,  $R_L = 20k\Omega$ , BW: 10-30kHz

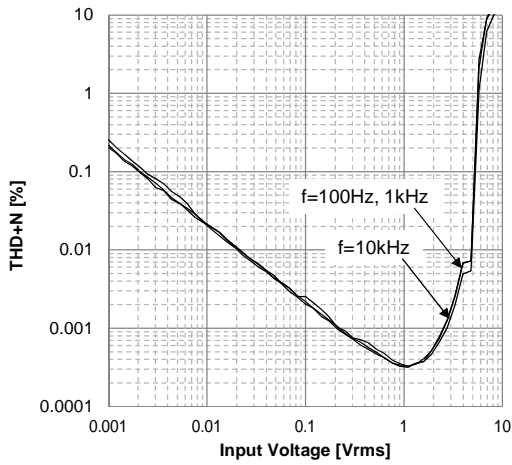

### THD+N vs Frequency

$V^+/V^- = \pm 7V$ ,  $R_L = 20k\Omega$ , BW: 10-80kHz

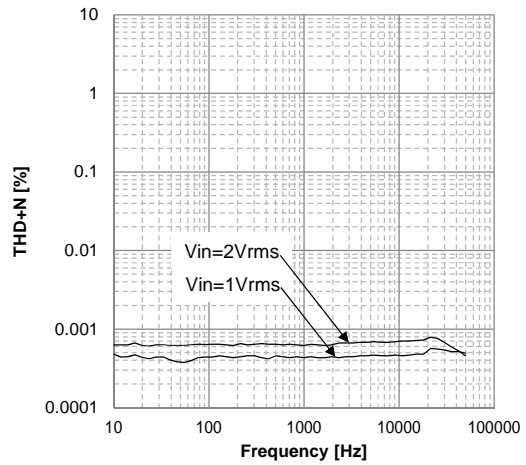

### Cross Talk vs Frequency

$V^+/V^- = \pm 7V$ ,  $V_{in} = 2V_{rms}$ ,  $R_L = 20k\Omega$ ,  
BW: Bandpass, I/O: InA2,3,4,5,6,7-OutA1,  
Rg: InA1, Select Channel=InA11

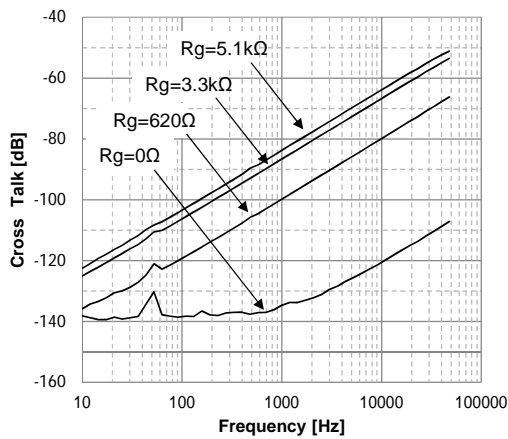

### Channel Separation vs Frequency

$V^+/V^- = \pm 7V$ ,  $V_{in} = 2V_{rms}$ ,  $R_L = 20k\Omega$ ,  
BW: Bandpass, I/O: InB1,2,3,4,5,6,7-OutA1,  
Rg: InA1, Select Channel=InA11, InB11-73

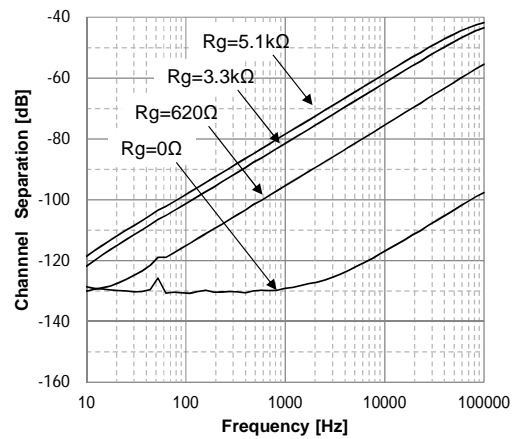

**[CAUTION]**  
The specifications on this databook are only given for information, without any guarantee as regards either mistakes or omissions. The application circuits in this databook are described only to show representative usages of the product and not intended for the guarantee or permission of any right including the industrial rights.

## X-ON Electronics

Largest Supplier of Electrical and Electronic Components

*Click to view similar products for [Multiplexer Switch ICs](#) category:*

*Click to view products by [Nisshinbo](#) manufacturer:*

Other Similar products are found below :

[NLV74HC4066ADR2G](#) [HEF4051BP](#) [MC74HC4067ADTG](#) [DG508AAK/883B](#) [NLV14051BDG](#) [016400E](#) [PI3V512QE](#) [7705201EC](#)  
[PI2SSD3212NCE](#) [NLAS3257CMX2TCG](#) [PI5A3157BC6EX](#) [PI3DBS12412AZLEX](#) [PI3V512QEX](#) [PI3DBS16213ZLEX](#) [PI3DBS16415ZHEX](#)  
[PS509LEX](#) [MUX36S16IRSNR](#) [74LVC1G3157GM-Q10X](#) [TC7W53FK,LF](#) [CD4053BM96](#) [MC74HC4053ADWR2G](#) [SN74LV4051APWR](#)  
[TC4066BP-NF](#) [HEF4053BT.653](#) [PI3L720ZHEX](#) [ADG5408BRUZ-REEL7](#) [ADG1404YRUZ-REEL7](#) [ADG1208YRZ-REEL7](#)  
[MAX4704EUB+T](#) [ADG1406BRUZ-REEL7](#) [CD4053BPWRG4](#) [74HC4053D.653](#) [74HCT4052PW.118](#) [74LVC2G53DP.125](#)  
[74HC4052DB.112](#) [74HC4052PW.112](#) [74HC4053DB.112](#) [74HC4067DB.112](#) [74HC4351DB.112](#) [74HCT4052D.112](#) [74HCT4052DB.112](#)  
[74HCT4053DB.112](#) [74HCT4351D.112](#) [74LV4051PW.112](#) [FSA1256L8X\\_F113](#) [PI5V330QE](#) [PI5V331QE](#) [5962-8771601EA](#) [5962-87716022A](#) [ADG5249FBRUZ](#)