

C-MOS QUAD SPST ANALOG SWITCH

■ GENERAL DESCRIPTION

The NJU7301 is a quad break-before-make SPST analog switch protected up to 44V operating voltage.

Each switch is controlled by TTL or C-MOS compatible input.

■ PACKAGE OUTLINE

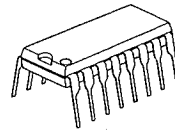

NJU7301D

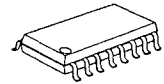

NJU7301M

■ FEATURES

- High Break Down Voltage -- 44V
- Package Outline -- DIP/DMP 16
- C-MOS Technology

■ PIN CONFIGURATION

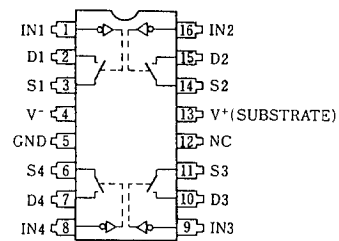

6

■ TRUTH TABLE

Logic (In)	Switch
0	ON
1	OFF

■ EQUIVALENT CIRCUIT

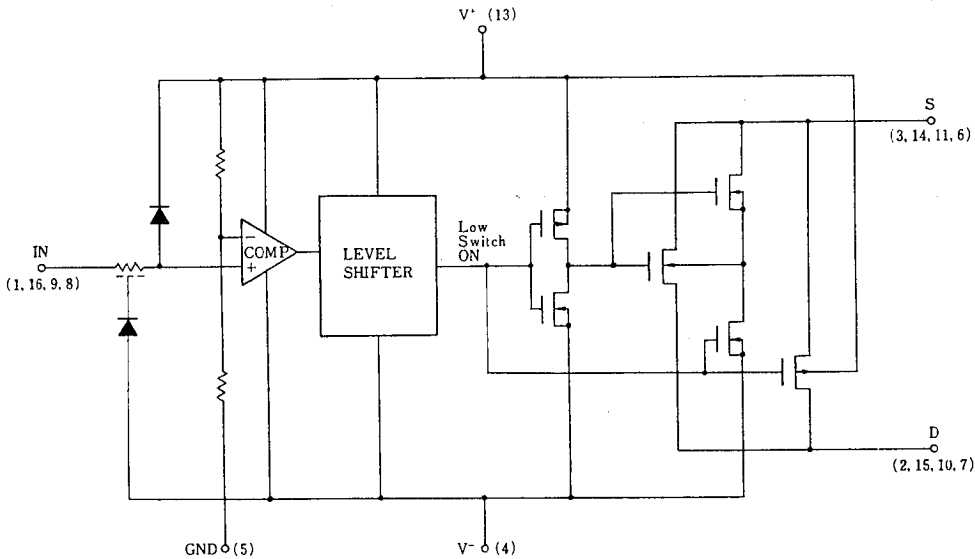

* Logic input threshold voltage V_{TH} is about $V^+ \times 0.128(V)$.
When the designing, enough margin is required.

■ TERMINAL DESCRIPTION

No.	SYMBOL	FUNCTION	No.	SYMBOL	FUNCTION
1	IN1	Control Signal Input	9	IN3	Control Signal Input
2	D1	Input/Output 1	10	D3	Input/Output 3
3	S1		11	S3	
4	V ⁻	Negative (V ⁻) Power Supply	12	NC	Non Connection
5	GND	Ground	13	V ⁺	Positive (V ⁺) Power Supply
6	S4	Input/Output 4	14	S2	Input/Output 2
7	D4		15	D2	
8	IN4	Control Signal Input	16	IN2	Control Signal Input

■ ABSOLUTE MAXIMUM RATINGS

(Ta=25°C)

PARAMETER	SYMBOL	RATINGS	UNIT
Supply Voltage	V ⁺ - V ⁻	44	V
	V ⁺ - GND	19	
	GND - V ⁻	25	
Input Voltage	V _I , V _S , V _D	V ⁻ -0.5 ~ V ⁺ +0.5 *	V
Input Current	I _I	30	mA
	I _S , I _D Continuous	20	
	Peak Value (PW=1ms, Duty0.1)	70	
Power Dissipation	P _D	500 (DIP) 200 (DMP)	mW
Operating Temperature Range	T _{opr}	0 ~ + 70	°C
Storage Temperature Range	T _{stg}	- 65 ~ + 125	°C

 * V⁺+0.5V must be 44V or less.

ELECTRICAL CHARACTERISTICS (DC CHARACTERISTICS)

 ($V^+=15V$, $V^-=-15V$, $GND=0V$)

PARAMETER	SYMBOL	CONDITIONS	TYP	MAX			UNIT	
			25°C	0°C	25°C	70°C		
Analog Signal Range	V_{ANALOG}		± 15		± 15	± 15	V	
On-state Resistance	R_{ON}	$V_{IN}=0.8V$ $V_D=10V$	105	200	200	250	Ω	
		$I_S=-1mA$ $V_D=-10V$	115	200	200	250		
Source-off Leakage Current	$I_S(off)$	$V_I=2.4V$	$V_S=14V, V_D=-14V$	0.01		5	100	nA
			$V_S=-14V, V_D=14V$	-0.02		-5	-100	
Drain-off Leakage Current	$I_D(off)$	$V_I=2.4V$	$V_D=14V, V_S=-14V$	0.01		5	100	nA
			$V_D=-14V, V_S=14V$	-0.02		-5	-100	
Drain-on Leakage Current	$I_D(on)$	$V_I=0.8V$	$V_D=V_S=14V$	0.1		5	200	nA
			$V_D=V_S=-14V$	-0.15		-5	-200	
Input Current	I_{IH}	$V_I=2.4V$	-0.0004		-1	-10	μA	
		$V_I=15V$	0.003		1	10		
	I_{IL}	$V_I=0V$	-0.0004		-1	-10		
Quiescent Current	I^+	$V_I=0$ or $2.4V$	0.9		2		mA	
	I^-		-0.3		-1			

SWITCHING CHARACTERISTICS

 ($V^+=15V$, $V^-=-15V$, $GND=0V$)

PARAMETER	SYMBOL	CONDITIONS	TYP	MAX			UNIT
			25°C	0°C	25°C	70°C	
Turn-on Time	t_{on}	$R_L=1k\Omega$, $C_L=35pF$	480		600		ns
Turn-off Time	t_{off}		370		450		
Charge Injection	Q	$C_L=1000pF$, $V_{GEN}=0V$, $R_{GEN}=0\Omega$	20				pC
Source-Off Capacit.	$C_S(off)$	$f=100kHz$	$V_S=0V$, $V_I=5V$	5			pF
Drain-Off Capacit.	$C_D(off)$		$V_D=0V$, $V_I=5V$	5			
Channel-On Capacitance	$C_D(on)$		$V_D=V_S=0V$,	16			
	$+C_S(on)$		$V_I=0V$				
Off Isolation	OIRR		$V_S=2V_{P-P}$, $R_L=75\Omega$	70			
Channel-to-channel Crosstalk	CCRR		90				

■ MEASUREMENT CIRCUITS

(1) Turn-on/Turn-off Time

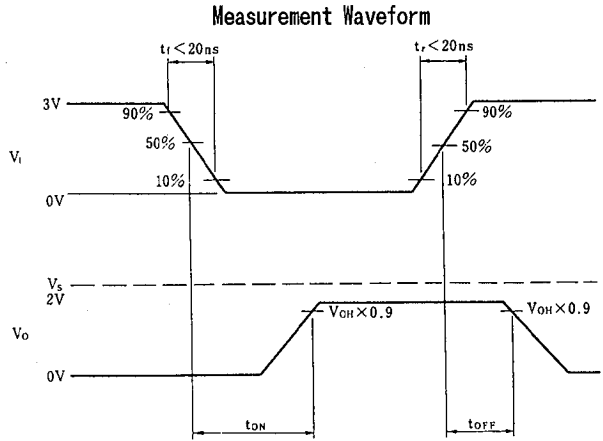
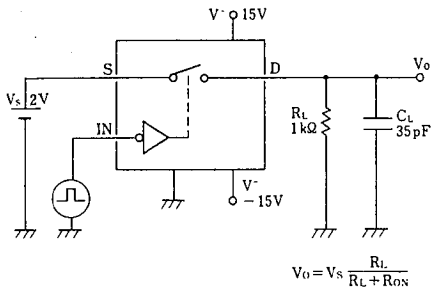

(2) Charge Injection

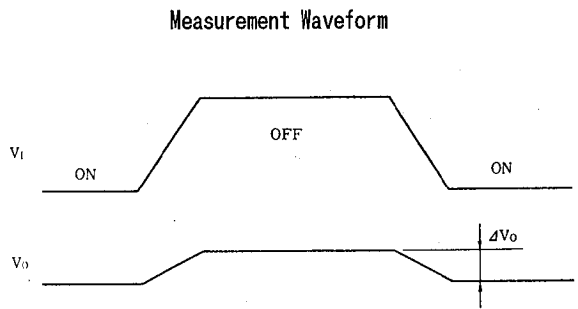
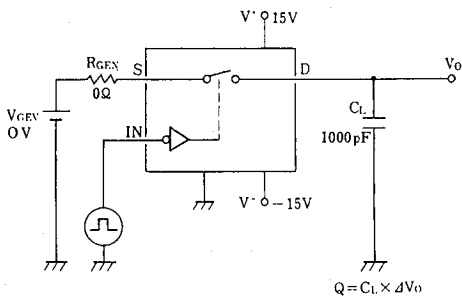

(3) Off Isolation

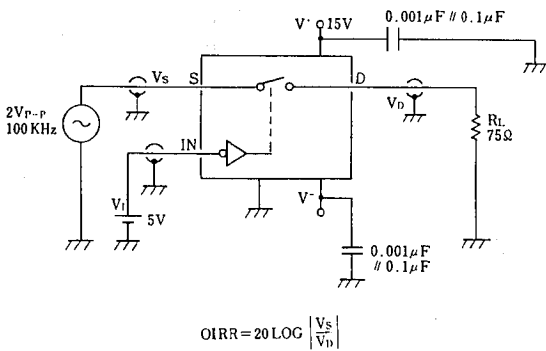

(4) Channel-To-Channel Crosstalk

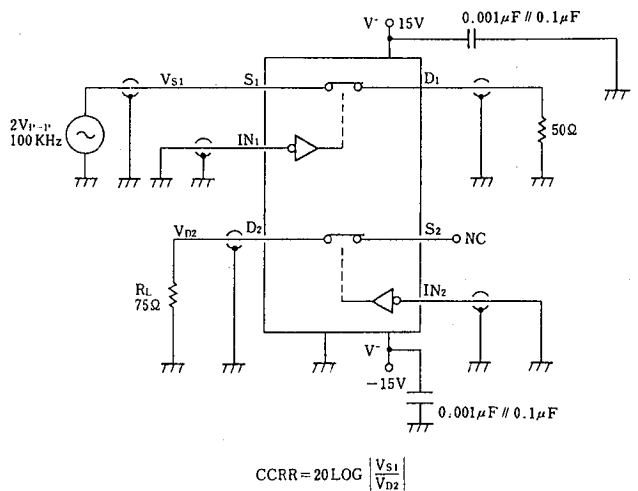

MEMO

[CAUTION]

The specifications on this databook are only given for information , without any guarantee as regards either mistakes or omissions. The application circuits in this databook are described only to show representative usages of the product and not intended for the guarantee or permission of any right including the industrial rights.

X-ON Electronics

Largest Supplier of Electrical and Electronic Components

Click to view similar products for [Analogue Switch ICs](#) category:

Click to view products by [Nisshinbo](#) manufacturer:

Other Similar products are found below :

[FSA3051TMX](#) [NLAS4684FCTCG](#) [NLAS5223BLMNR2G](#) [NLX2G66DMUTCG](#) [425541DB](#) [425528R](#) [099044FB](#) [NLAS5123MNR2G](#)
[PI5A4157CEX](#) [NLAS4717EPFCT1G](#) [PI5A3167CCEX](#) [SLAS3158MNR2G](#) [PI5A392AQE](#) [PI5A4157ZUEX](#) [PI5A3166TAEX](#) [FSA634UCX](#)
[XS3A1T3157GMX](#) [TC4066BP\(N,F\)](#) [DG302BDJ-E3](#) [PI5A100QEX](#) [HV2605FG-G](#) [HV2301FG-G](#) [RS2117YUTQK10](#) [RS2118YUTQK10](#)
[RS2227XUTQK10](#) [ADG452BRZ-REEL7](#) [MAX4066ESD+](#) [MAX391CPE+](#) [MAX4730EXT+T](#) [MAX314CPE+](#) [BU4066BCFV-E2](#)
[MAX313CPE+](#) [BU4S66G2-TR](#) [NLASB3157MTR2G](#) [TS3A4751PWR](#) [NLAST4599DFT2G](#) [NLAST4599DTT1G](#) [DG300BDJ-E3](#)
[DG2503DB-T2-GE1](#) [TC4W53FU\(Te12L,F\)](#) [HV2201FG-G](#) [74HC2G66DC.125](#) [DG3257DN-T1-GE4](#) [ADG619BRMZ-REEL](#)
[ADG1611BRUZ-REEL7](#) [DG2535EDQ-T1-GE3](#) [LTC201ACN#PBF](#) [74LV4066DB,118](#) [ISL43410IUZ](#) [FSA2275AUMX](#)