

## SMALL PACKAGE VOLTAGE INVERTER

### ■ GENERAL DESCRIPTION

The **NJU7665** series is a voltage inverter incorporated RC oscillator, pre-buffer and power-MOS, which generates a polarity-converted negative voltage from +1.5V to +5.5V.

The switching frequency is fixed by internal RC oscillator and the following line-up of 3 version are available to select.

The **NJU7665** series is in MTP-5 package and it is suitable for battery use items and other portable items.

### ■ PACKAGE OUTLINE



**NJU7665XF**

### ■ FEATURES

- Input Voltage : 1.5 to 5.5V
- Switching Frequency : fsw = 7.5k, 75k, 150kHz
- Low Output Resistance : 75Ω MAX. (C version, C = 1μF, V<sub>IN</sub> = 3V)
- Low Operating Current : 100μA MAX. (A version)
- C-MOS Technology
- Package Outline : MTP-5

### ■ LINE-UP TABLE

TYPE NO.	Switching Frequency	Supply Current	Output Resistance
NJU7665A	7.5kHz (typ.)	100μA (max.)	1kΩ (max.)
NJU7665B	75kHz (typ.)	0.65mA (max.)	100Ω (max.)
NJU7665C	150kHz (typ.)	1.4mA (max.)	75Ω (max.)

### ■ BLOCK DIAGRAM

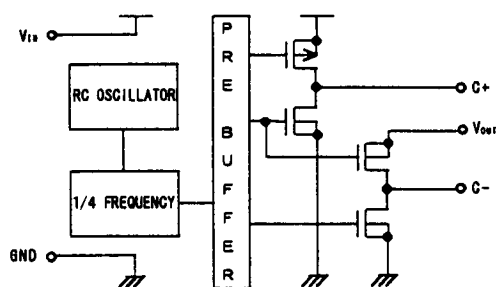

### ■ PIN CONFIGURATION

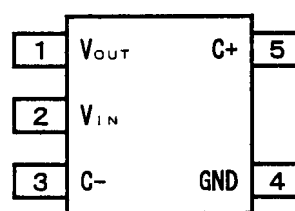

### ■ TERMINAL DESCRIPTION

Terminal No.	Symbol	Function
1	V <sub>OUT</sub>	Output Voltage
2	V <sub>IN</sub>	Power Supply Terminal
3	C <sup>-</sup>	Charge Pump Capacitor (-) Connecting Terminal
4	GND	Ground Terminal
5	C <sup>+</sup>	Charge Pump Capacitor (+) Connecting Terminal

# NJU7665 Series

## ■ ABSOLUTE MAXIMUM RATINGS

( $T_a = 25^\circ\text{C}$ )

PARAMETER	SYMBOL	RATINGS	UNIT
Input Supply Voltage	$V_{IN}$	-0.3 to 6.0	V
Power Dissipation	$P_D$	200	mW
Operating Temperature	$T_{opr}$	-40 to +85	$^\circ\text{C}$
Storage Temperature	$T_{stg}$	-55 to +125	$^\circ\text{C}$

Note1) Decoupling capacitor should be connected between  $V_{IN}$  and GND due to the stabilized operation for the IC.

## ■ ELECTRICAL CHARACTERISTICS

A version

( $V_{IN} = 3.0\text{V}$ ,  $C_1 = C_2 = 1\mu\text{F}$ ,  $T_a = 25^\circ\text{C}$ )

PARAMETER	SYMBOL	CONDITION	MIN.	TYP.	MAX.	UNIT
Supply Current	$I_{IN}$	$R_L = \infty$	–	–	100	$\mu\text{A}$
Input Supply Voltage	$V_{IN}$	$-40^\circ\text{C} \leq T_a \leq 85^\circ\text{C}$	1.5	–	5.5	V
Output Resistance	$R_{OUT}$	$I_{OUT} = 500\mu\text{A}$	–	–	1.0	$\text{k}\Omega$
Switching Frequency	$F_{SW}$		4.5	7.5	10.5	$\text{kHz}$
Voltage Conversion Rate	$V_{EF}$	$R_L = \infty$	90	99.3	–	%

B version

( $V_{IN} = 3.0\text{V}$ ,  $C_1 = C_2 = 1\mu\text{F}$ ,  $T_a = 25^\circ\text{C}$ )

PARAMETER	SYMBOL	CONDITION	MIN.	TYP.	MAX.	UNIT
Supply Current	$I_{IN}$	$R_L = \infty$	–	–	0.65	$\text{mA}$
Input Supply Voltage	$V_{IN}$	$-40^\circ\text{C} \leq T_a \leq 85^\circ\text{C}$	1.5	–	5.5	V
Output Resistance	$R_{OUT}$	$I_{OUT} = 5\text{mA}$	–	–	100	$\Omega$
Switching Frequency	$F_{SW}$		40	75	100	$\text{kHz}$
Voltage Conversion Rate	$V_{EF}$	$R_L = \infty$	90	99.3	–	%

C version

( $V_{IN} = 3.0\text{V}$ ,  $C_1 = C_2 = 1\mu\text{F}$ ,  $T_a = 25^\circ\text{C}$ )

PARAMETER	SYMBOL	CONDITION	MIN.	TYP.	MAX.	UNIT
Supply Current	$I_{IN}$	$R_L = \infty$	–	–	1.4	$\text{mA}$
Input Supply Voltage	$V_{IN}$	$-40^\circ\text{C} \leq T_a \leq 85^\circ\text{C}$	1.5	–	5.5	V
Output Resistance	$R_{OUT}$	$I_{OUT} = 10\text{mA}$	–	–	75	$\Omega$
Switching Frequency	$F_{SW}$		80	150	200	$\text{kHz}$
Voltage Conversion Rate	$V_{EF}$	$R_L = \infty$	90	99.3	–	%

NOTE2) Please minimize the wiring impedance of C+, C- terminals due to the power conversion rate.

**CHARACTERISTICS**

**Power Conversion Rate vs. Output Current**  
 ( $V_{IN}=3V, C1=C2=C3=1\mu F/50V, T_a=25^\circ C$ )

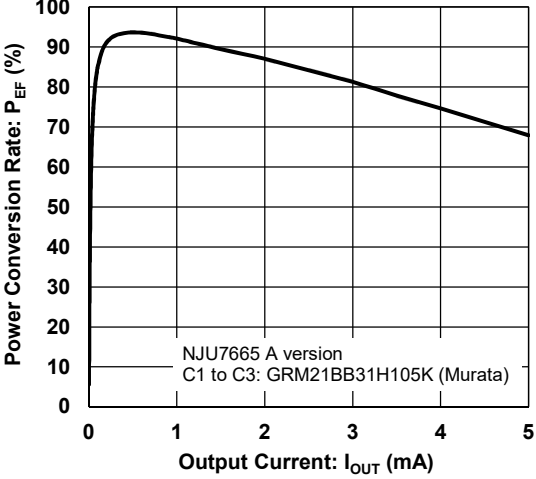

**Output Voltage vs. Output Current**  
 ( $V_{IN}=3V, C1=C2=C3=1\mu F/50V, T_a=25^\circ C$ )

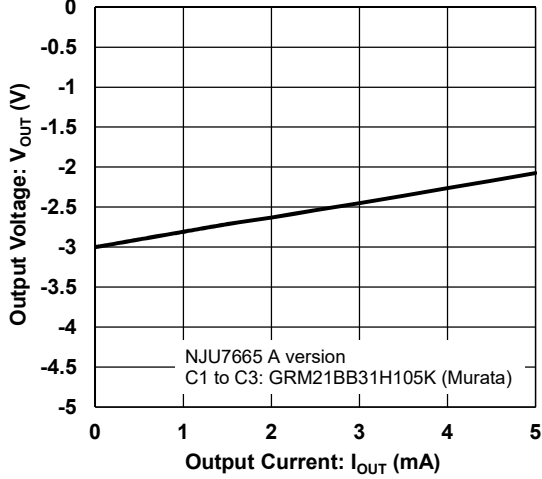

**Power Conversion Rate vs. Output Current**  
 ( $V_{IN}=3V, C1=C2=C3=1\mu F/50V, T_a=25^\circ C$ )

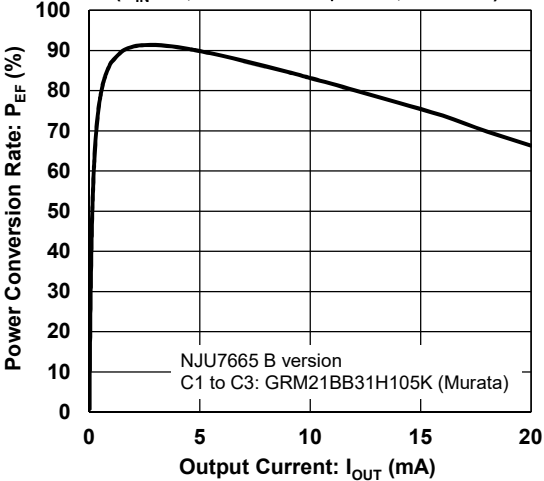

**Output Voltage vs. Output Current**  
 ( $V_{IN}=3V, C1=C2=C3=1\mu F/50V, T_a=25^\circ C$ )

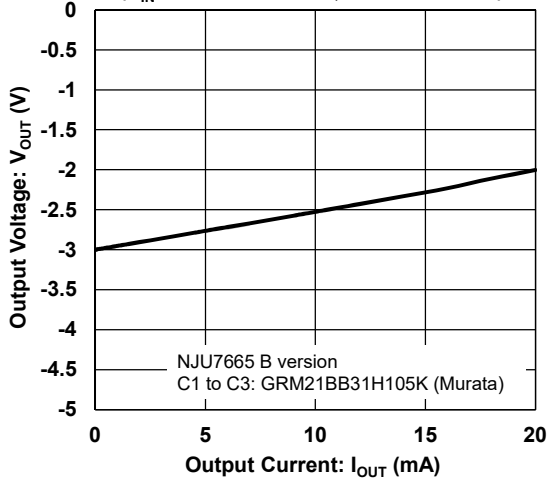

**Power Conversion Rate vs. Output Current**  
 ( $V_{IN}=3V, C1=C2=C3=1\mu F/50V, T_a=25^\circ C$ )

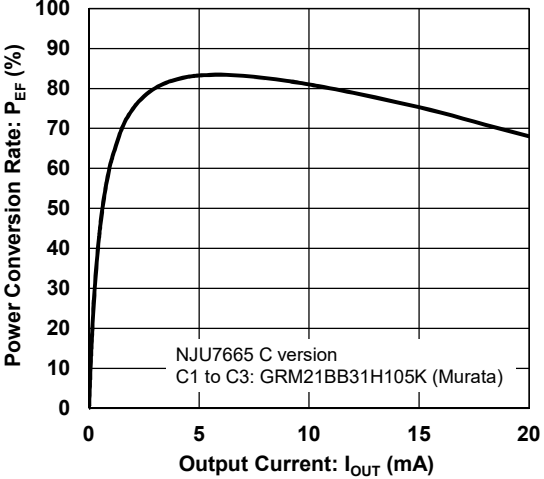

**Output Voltage vs. Output Current**  
 ( $V_{IN}=3V, C1=C2=C3=1\mu F/50V, T_a=25^\circ C$ )

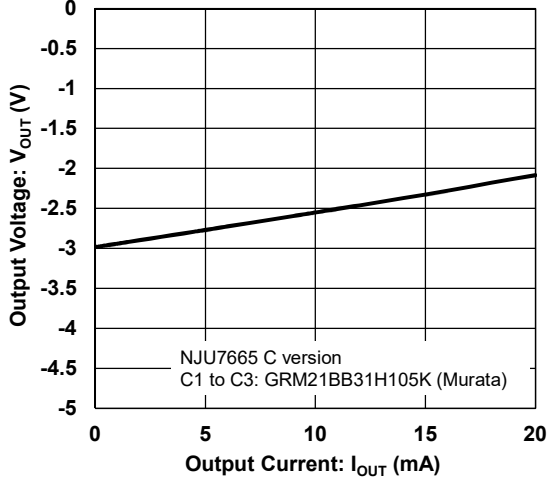

# NJU7665 Series

## APPLICATION CIRCUIT

### 1. Negative Voltage Output Circuit

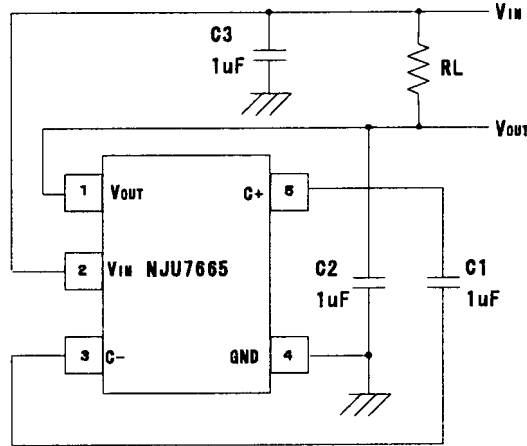

### 2. Parallel Connection Circuit

The following circuit reduce the output impedance.

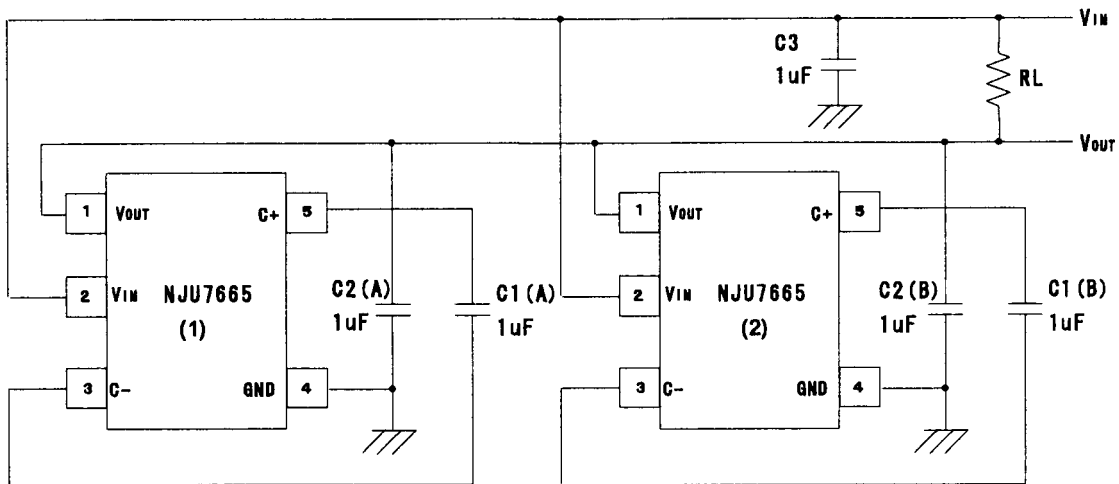

[CAUTION]  
The specifications on this databook are only given for information, without any guarantee as regards either mistakes or omissions. The application circuits in this databook are described only to show representative usages of the product and not intended for the guarantee or permission of any right including the industrial rights.

## X-ON Electronics

Largest Supplier of Electrical and Electronic Components

*Click to view similar products for [Switching Voltage Regulators](#) category:*

*Click to view products by [Nisshinbo](#) manufacturer:*

Other Similar products are found below :

[FAN53610AUC33X](#) [FAN53611AUC123X](#) [FAN48610BUC33X](#) [FAN48610BUC45X](#) [FAN48617UC50X](#) [R3](#) [430464BB](#) [KE177614](#)  
[MAX809TTR](#) [NCV891234MW50R2G](#) [NCP81103MNTXG](#) [NCP81203PMNTXG](#) [NCP81208MNTXG](#) [NCP81109GMNTXG](#)  
[SCY1751FCCT1G](#) [NCP81109JMNTXG](#) [AP3409ADNTR-G1](#) [NCP81241MNTXG](#) [LTM8064IY](#) [LT8315EFE#TRPBF](#) [NCV1077CSTBT3G](#)  
[XCL207A123CR-G](#) [MPM54304GMN-0002](#) [MPM54304GMN-0003](#) [XDPE132G5CG000XUMA1](#) [MP8757GL-P](#) [MIC23356YFT-TR](#)  
[LD8116CGL](#) [HG2269M/TR](#) [OB2269](#) [XD3526](#) [U6215A](#) [U6215B](#) [U6620S](#) [LTC3803ES6#TR](#) [LTC3803ES6#TRM](#) [LTC3412IFE](#) [LT1425IS](#)  
[MAX25203BATJA/VY+](#) [MAX77874CEWM+](#) [XC9236D08CER-G](#) [ISL95338IRTZ](#) [MP3416GJ-P](#) [BD9S201NUX-CE2](#) [MP5461GC-Z](#)  
[MPQ4415AGQB-Z](#) [MPQ4590GS-Z](#) [MCP1603-330IMC](#) [MCP1642B-18IMC](#) [MCP1642D-ADJIMC](#)