

## LOW DROPOUT VOLTAGE REGULATOR

### ■ GENERAL DESCRIPTION

NJU7771/72/73/74/75/76 is a low dropout voltage regulator designed for portable items.

Advanced CMOS technology achieves high ripple rejection and low quiescent current.

NJU7774/75/76 features shunt switch which improves turn off response of output voltage when ON/OFF control is used.

### ■ FEATURES

- High Ripple Rejection      65dB typ. (f=1kHz, Vo=3.0V version)
- Low quiescent Current      Iq=18μA (Io=0mA)
- Output capacitor with 1.0μF ceramic capacitor (Vo>2.0V version)
- Output Current              Io(max.)=150mA
- High Precision Output      Vo±1.0%
- Low Dropout Voltage        0.15V typ. (Io=100mA, Vo=3.0V)
- Input Voltage Range        VIN=+2.3V~9V (Vo≤2.0V version)
- ON/OFF Control              (Active High)
- With Shunt Switch           Only NJU7774/75/76
- Internal Short Circuit Current Limit
- Internal Thermal Overload Protection
- CMOS Technology
- Package Outline              SOT-23-5

### ■ PACKAGE OUTLINE

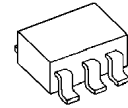

NJU777\*F

### ■ PIN CONFIGURATION

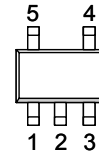

PIN FUNCTION

1.CONTROL	1.V <sub>IN</sub>	1.V <sub>OUT</sub>
2.GND	2.GND	2.GND
3.NC	3.CONTROL	3.V <sub>IN</sub>
4.V <sub>OUT</sub>	4.NC	4.CONTROL
5.V <sub>IN</sub>	5.V <sub>OUT</sub>	5.NC
NJU7771F	NJU7772F	NJU7773F
NJU7774F	NJU7775F	NJU7776F

### ■ EQUIVALENT CIRCUIT

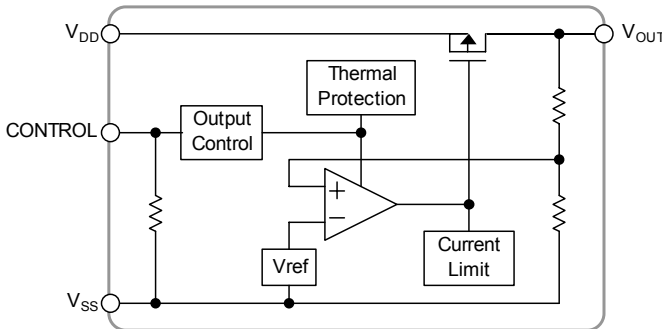

NJM7771/72/73

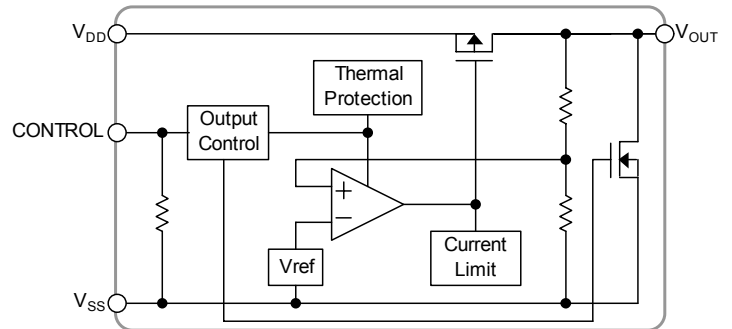

NJM7774/75/76

# NJU7771/72/73/74/75/76

## ■ OUTPUT VOLTAGE RANK LIST

### ● NJM7771

Device Name	V <sub>OUT</sub>	Device Name	V <sub>OUT</sub>	Device Name	V <sub>OUT</sub>	Device Name	V <sub>OUT</sub>
NJU7771F15	1.5V	NJU7771F23	2.3V	NJU7771F32	3.2V	NJU7771F04	4.0V
NJU7771F18	1.8V	NJU7771F25	2.5V	NJU7771F33	3.3V	NJU7771F42	4.2V
NJU7771F19	1.9V	NJU7771F27	2.7V	NJU7771F35	3.5V	NJU7771F05	5.0V
NJU7771F21	2.1V	NJU7771F28	2.8V	NJU7771F36	3.6V		
NJU7771F22	2.2V	NJU7771F03	3.0V	NJU7771F38	3.8V		

### ● NJM7772

Device Name	V <sub>OUT</sub>	Device Name	V <sub>OUT</sub>	Device Name	V <sub>OUT</sub>	Device Name	V <sub>OUT</sub>
NJU7772F15	1.5V	NJU7772F23	2.3V	NJU7772F32	3.2V	NJU7772F04	4.0V
NJU7772F18	1.8V	NJU7772F25	2.5V	NJU7772F33	3.3V	NJU7772F42	4.2V
NJU7772F19	1.9V	NJU7772F27	2.7V	NJU7772F35	3.5V	NJU7772F05	5.0V
NJU7772F21	2.1V	NJU7772F28	2.8V	NJU7772F36	3.6V		
NJU7772F22	2.2V	NJU7772F03	3.0V	NJU7772F38	3.8V		

### ● NJM7773

Device Name	V <sub>OUT</sub>	Device Name	V <sub>OUT</sub>	Device Name	V <sub>OUT</sub>	Device Name	V <sub>OUT</sub>
NJU7773F15	1.5V	NJU7773F23	2.3V	NJU7773F32	3.2V	NJU7773F04	4.0V
NJU7773F18	1.8V	NJU7773F25	2.5V	NJU7773F33	3.3V	NJU7773F42	4.2V
NJU7773F19	1.9V	NJU7773F27	2.7V	NJU7773F35	3.5V	NJU7773F05	5.0V
NJU7773F21	2.1V	NJU7773F28	2.8V	NJU7773F36	3.6V		
NJU7773F22	2.2V	NJU7773F03	3.0V	NJU7773F38	3.8V		

### ● NJM7774

Device Name	V <sub>OUT</sub>	Device Name	V <sub>OUT</sub>	Device Name	V <sub>OUT</sub>	Device Name	V <sub>OUT</sub>
NJU7774F15	1.5V	NJU7774F25	2.5V	NJU7774F33	3.3V	NJU7774F05	5.0V
NJU7774F18	1.8V	NJU7774F27	2.7V	NJU7774F35	3.5V		
NJU7774F21	2.1V	NJU7774F28	2.8V	NJU7774F38	3.8V		
NJU7774F22	2.2V	NJU7774F03	3.0V	NJU7774F04	4.0V		
NJU7774F23	2.3V	NJU7774F32	3.2V	NJU7774F42	4.2V		

### ● NJM7775

Device Name	V <sub>OUT</sub>	Device Name	V <sub>OUT</sub>	Device Name	V <sub>OUT</sub>	Device Name	V <sub>OUT</sub>
NJU7775F15	1.5V	NJU7775F25	2.5V	NJU7775F33	3.3V	NJU7775F05	5.0V
NJU7775F18	1.8V	NJU7775F27	2.7V	NJU7775F35	3.5V		
NJU7775F21	2.1V	NJU7775F28	2.8V	NJU7775F38	3.8V		
NJU7775F22	2.2V	NJU7775F03	3.0V	NJU7775F04	4.0V		
NJU7775F23	2.3V	NJU7775F32	3.2V	NJU7775F42	4.2V		

### ● NJM7776

Device Name	V <sub>OUT</sub>	Device Name	V <sub>OUT</sub>	Device Name	V <sub>OUT</sub>	Device Name	V <sub>OUT</sub>
NJU7776F15	1.5V	NJU7776F25	2.5V	NJU7776F33	3.3V	NJU7776F05	5.0V
NJU7776F18	1.8V	NJU7776F27	2.7V	NJU7776F35	3.5V		
NJU7776F21	2.1V	NJU7776F28	2.8V	NJU7776F38	3.8V		
NJU7776F22	2.2V	NJU7776F03	3.0V	NJU7776F04	4.0V		
NJU7776F23	2.3V	NJU7776F32	3.2V	NJU7776F42	4.2V		

## ■ ABSOLUTE MAXIMUM RATINGS

(Ta=25°C)

PARAMETER	SYMBOL	RATINGS	UNIT
Input Voltage	V <sub>IN</sub>	+10	V
Control Voltage	V <sub>CONT</sub>	+10(*1)	V
Power Dissipation	P <sub>D</sub>	SOT-23-5	350(*2)
			200(*3)
Operating Temperature	T <sub>opr</sub>	-40 ~ +85	°C
Storage Temperature	T <sub>stg</sub>	-40 ~ +125	°C
OFF-state Output Sink Current(*4)	I <sub>o</sub>	10	mA

(\*1): When input voltage is less than +10V, the absolute maximum control voltage is equal to the input voltage.

(\*2) : Mounted on glass epoxy board based on EIA/JEDEC. (114.3x76.2x1.6mm: 2Layers)

(\*3) : Device itself

(\*4): This maximum rating is applied to NJU7774/75/76.

## ■ Operating voltage

V<sub>IN</sub>=+2.3 ~ +14V (In case of Vo<2.1V version)

## ■ ELECTRICAL CHARACTERISTICS

(V<sub>IN</sub>=Vo+1V, C<sub>IN</sub>=0.1μF, Co=1.0μF(Co=2.2μF: Vo≤2.0V), Ta=25°C)

PARAMETER	SYMBOL	TEST CONDITION	MIN.	TYP.	MAX.	UNIT
Output Voltage	V <sub>o</sub>	I <sub>o</sub> =30mA	-1.0%	-	+1.0%	V
Input Voltage	V <sub>IN</sub>		-	-	9	V
Quiescent Current	I <sub>Q</sub>	I <sub>o</sub> =0mA, V <sub>CONT</sub> =V <sub>IN</sub>	-	18	35	μA
Quiescent Current at Control OFF	I <sub>Q(OFF)</sub>	V <sub>CONT</sub> =0V	-	0.1	1	μA
Output Current	I <sub>o</sub>	V <sub>o</sub> -0.1V (V <sub>o</sub> ≤2.0V)	150	-	-	mA
		V <sub>o</sub> -0.3V (V <sub>o</sub> ≥2.1V)				
Short Current Limit	I <sub>LIM</sub>	V <sub>o</sub> =0V	-	50	-	mA
Line Regulation	Δ V <sub>o</sub> /Δ V <sub>IN</sub>	V <sub>IN</sub> =Vo+1V ~ Vo+6.0V (V <sub>o</sub> <3.0V) V <sub>IN</sub> =Vo+1V ~ 9.0V (V <sub>o</sub> ≥3.0V), I <sub>o</sub> =30mA	-	-	0.20	%/V
Load Regulation	Δ V <sub>o</sub> /Δ I <sub>o</sub>	I <sub>o</sub> =0 ~ 100mA	-	-	0.03	%/mA
Dropout Voltage(*note 3)	Δ V <sub>I-O</sub>	I <sub>o</sub> =100mA, 2.1V≤V <sub>o</sub> ≤2.4V	-	0.2	0.3	V
		I <sub>o</sub> =100mA, 2.5V≤V <sub>o</sub> ≤2.7V	-	0.18	0.28	V
		I <sub>o</sub> =100mA, 2.8V≤V <sub>o</sub> ≤3.3V	-	0.15	0.25	V
		I <sub>o</sub> =100mA, 3.4V≤V <sub>o</sub> ≤5.0V	-	0.12	0.22	V
Ripple Rejection	RR	e <sub>in</sub> =200mVrms, f=1kHz, I <sub>o</sub> =10mA, V <sub>o</sub> =3.0V Version	-	65	-	dB
Average Temperature Coefficient of Output Voltage	Δ V <sub>o</sub> /Δ Ta	Ta=0 ~ 85°C, I <sub>o</sub> =10mA	-	±100	-	ppm/°C
Output Noise Voltage	V <sub>NO1</sub>	f=10Hz ~ 80kHz, I <sub>o</sub> =0mA, V <sub>o</sub> =3.0V Version	-	40	-	μVrms
	V <sub>NO2</sub>	f=10Hz~80kHz, I <sub>o</sub> =10mA, V <sub>o</sub> =3.0V Version	-	70	-	μVrms
Pull-down Resistance	R <sub>CONT</sub>		2	5	10	MΩ
Control Voltage for ON-state	V <sub>CONT(ON)</sub>		1.6	-	-	V
Control Voltage for OFF-state	V <sub>CONT(OFF)</sub>		-	-	0.3	V
Pull-down Resistance at OFF-state(*6)	R <sub>O(OFF)</sub>	V <sub>CONT</sub> =0V (V <sub>o</sub> =3.0V Version)	-	120	-	Ω

(\*5): Except output voltage less than 2.1V.

(\*6) This electrical characteristics is applied to NJU7774/75/76.

The above specification is a common specification for all output voltages.

Therefore, it may be different from the individual specification for a specific output voltage.

# NJU7771/72/73/74/75/76

## TEST CIRCUIT

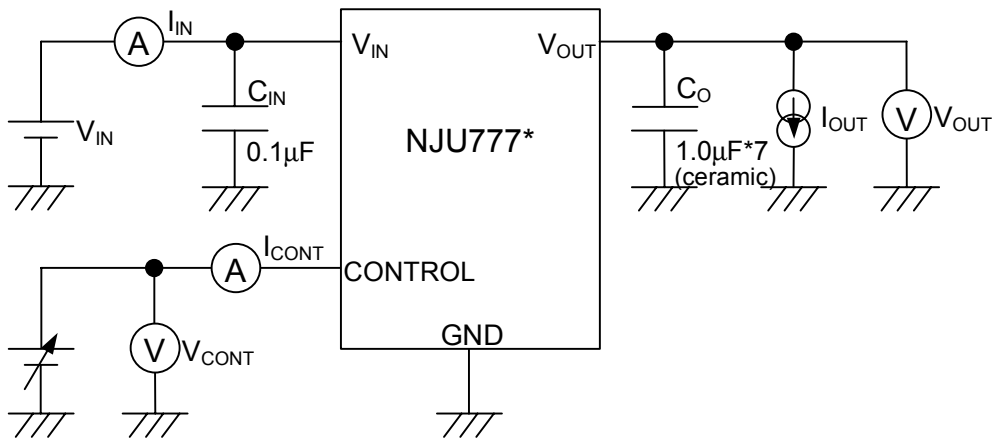

\*7 Vo≤2.0V version: Co=2.2μF(ceramic)

## POWER DISSIPATION vs. AMBIENT TEMPERATURE

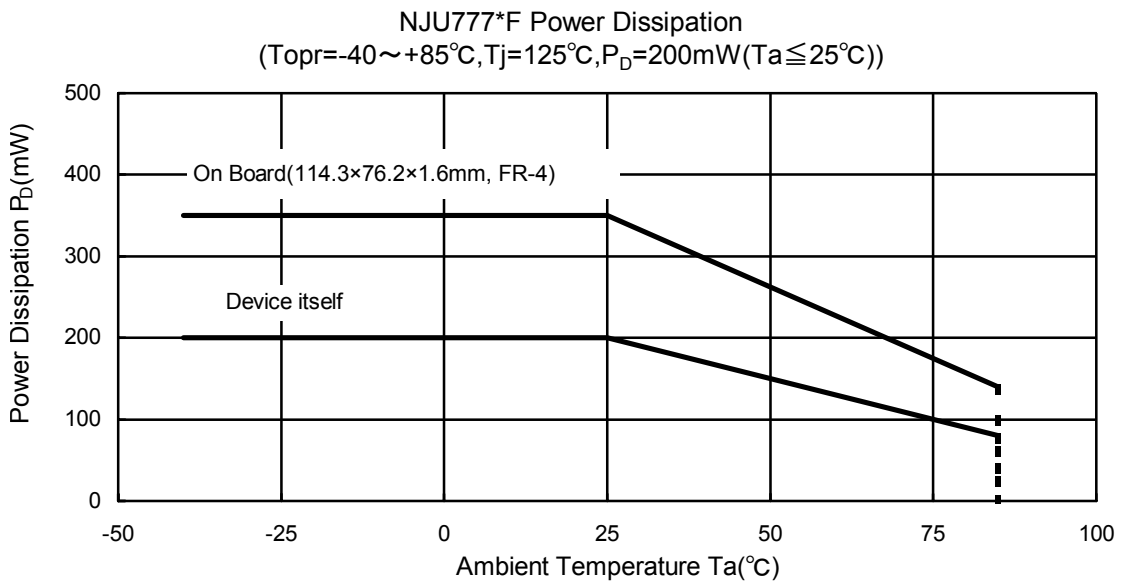

## ■ TYPICAL APPLICATION

① In case that ON/OFF Control is not required:

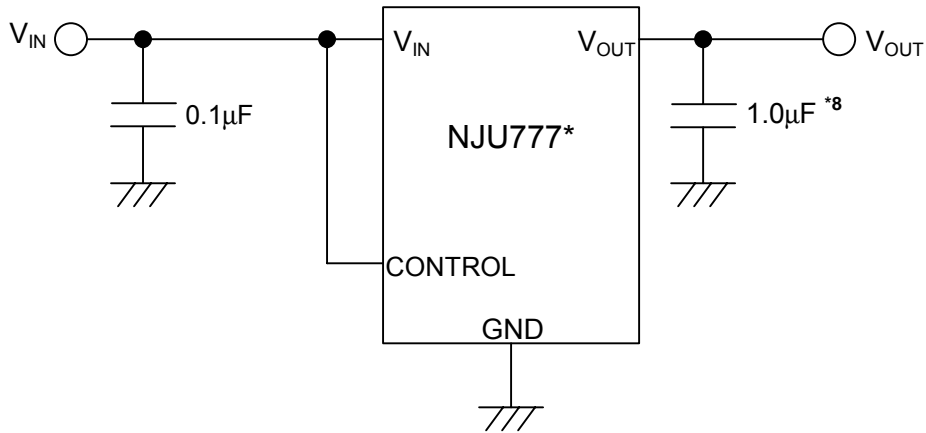

\*8  $V_o \leq 2.0V$  version:  $C_o = 2.2\mu F$

Connect control terminal to  $V_{IN}$  terminal.

② In use of ON/OFF Control

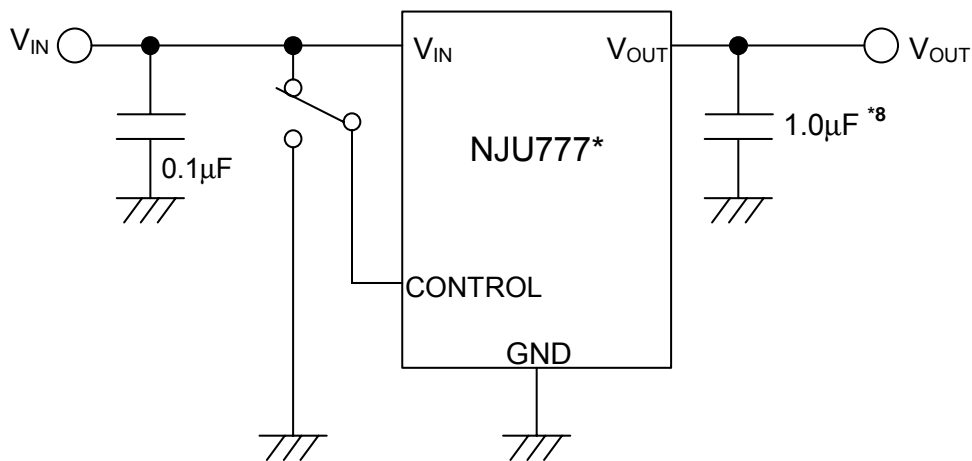

\*8  $V_o \leq 2.0V$  version:  $C_o = 2.2\mu F$

State of control terminal:

- "H" → output is enabled.
- "L" or "open" → output is disabled.

# NJU7771/72/73/74/75/76

## ■ ELECTRICAL CHARACTERISTICS

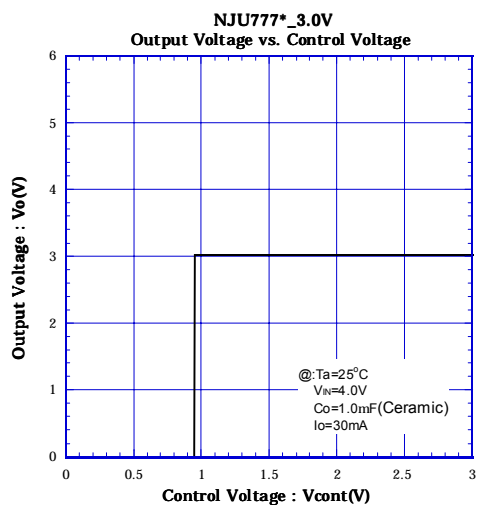
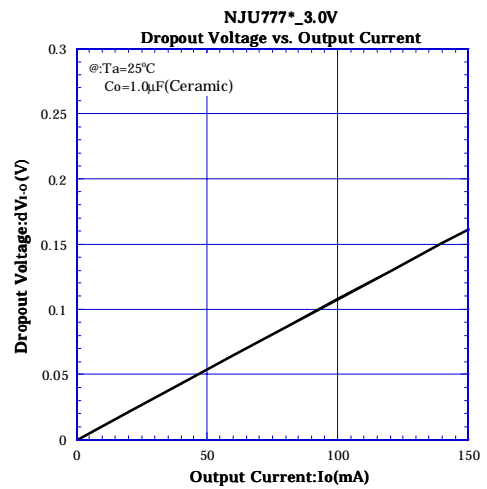
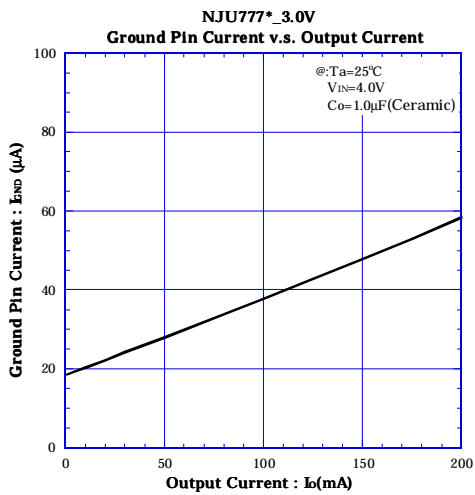
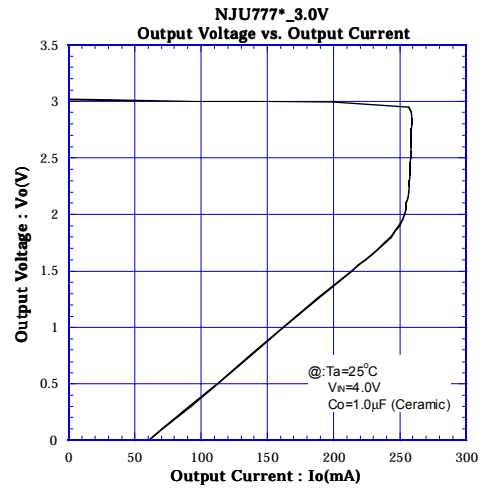
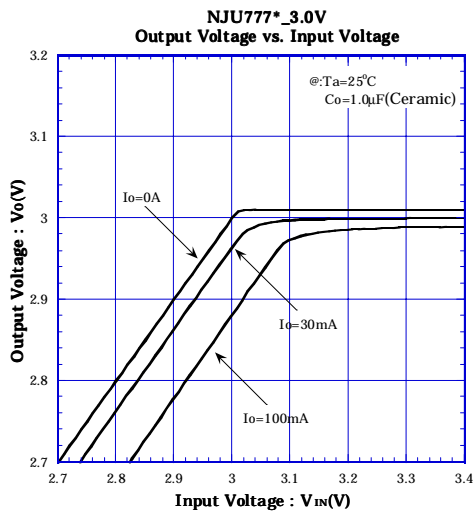

## ELECTRICAL CHARACTERISTICS

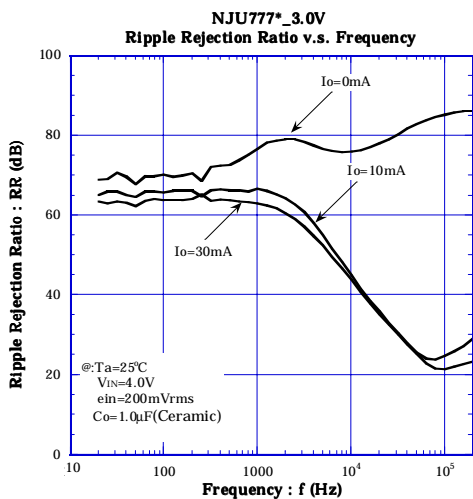
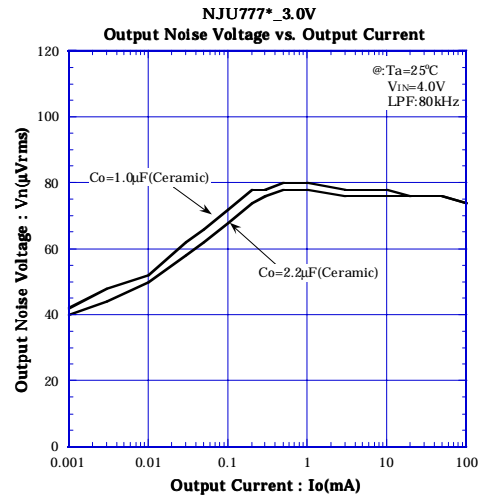
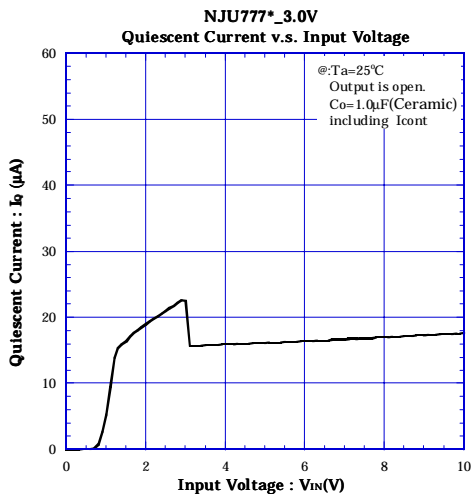
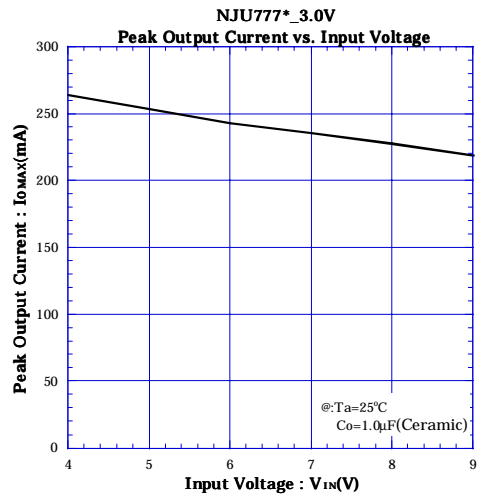
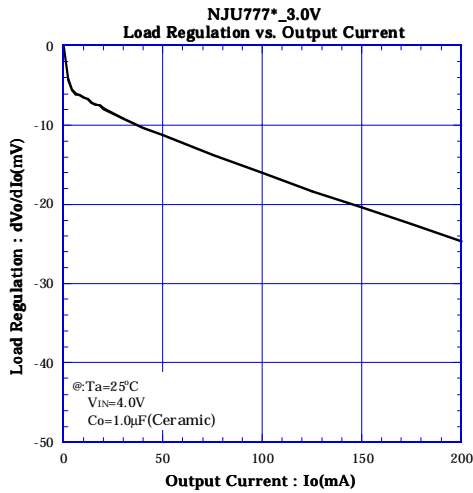

# NJU7771/72/73/74/75/76

## ELECTRICAL CHARACTERISTICS

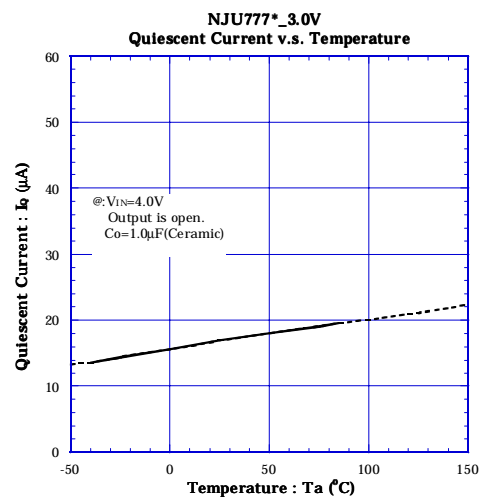
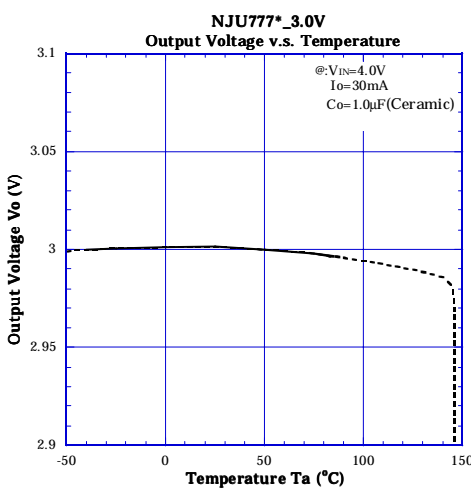
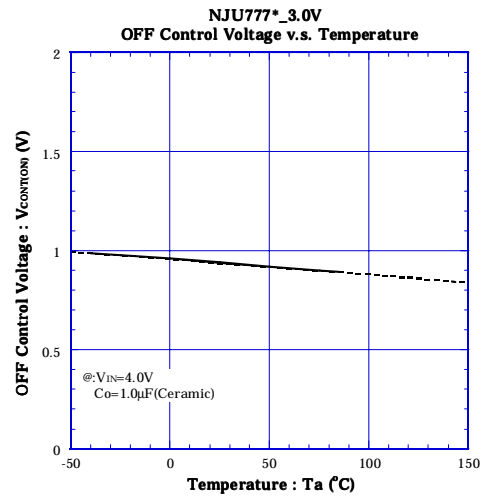
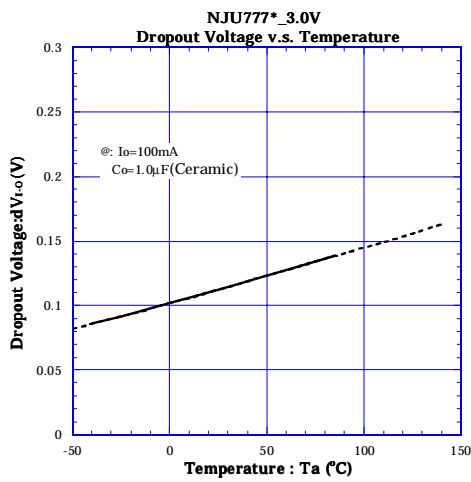
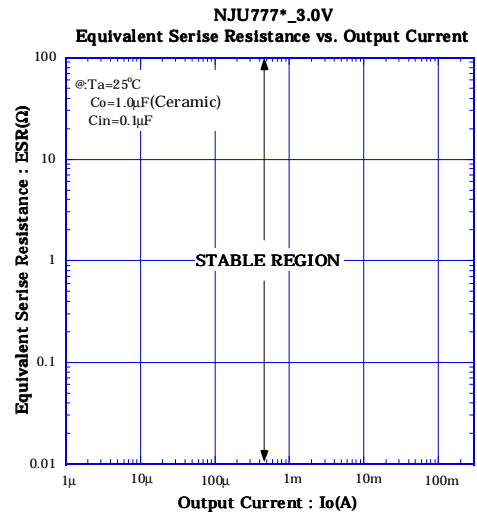
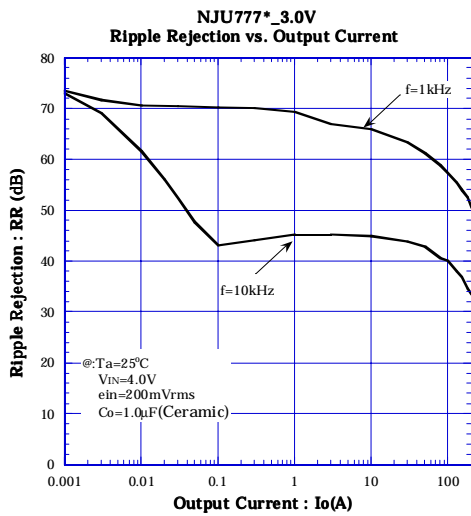



## ■ ELECTRICAL CHARACTERISTICS

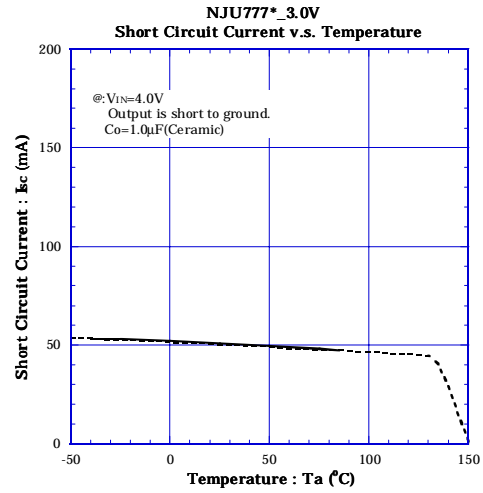
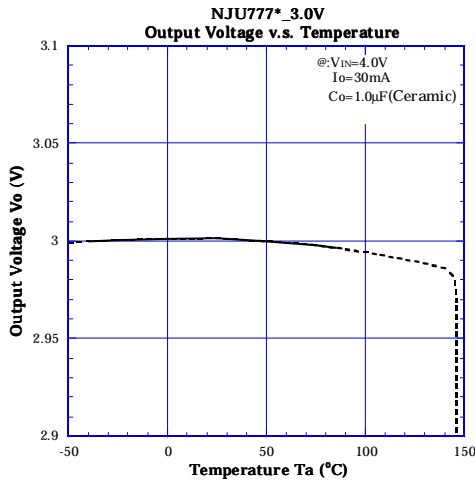
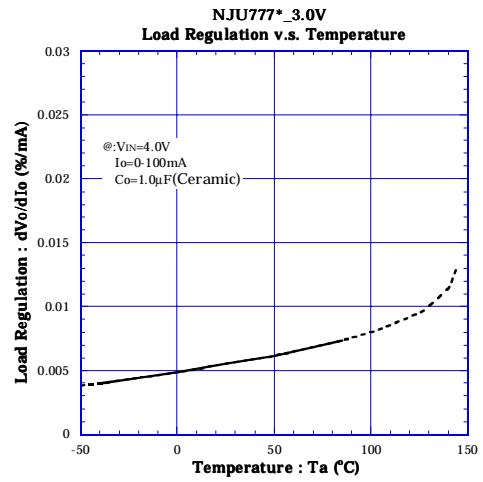
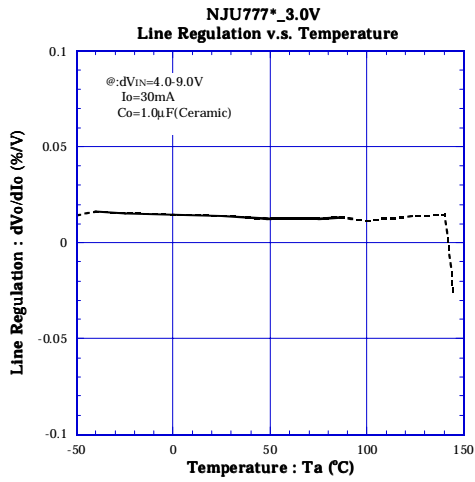

# NJU7771/72/73/74/75/76

## ■ ELECTRICAL CHARACTERISTICS

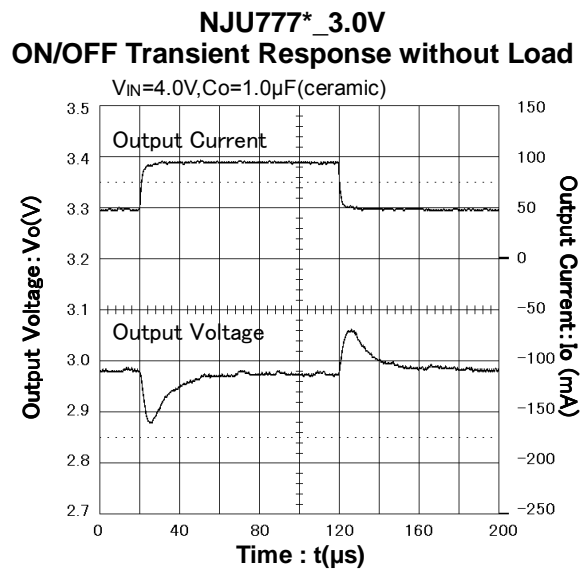
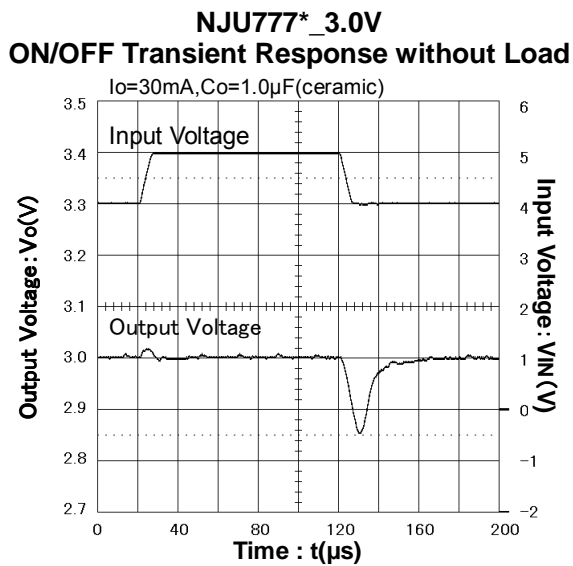
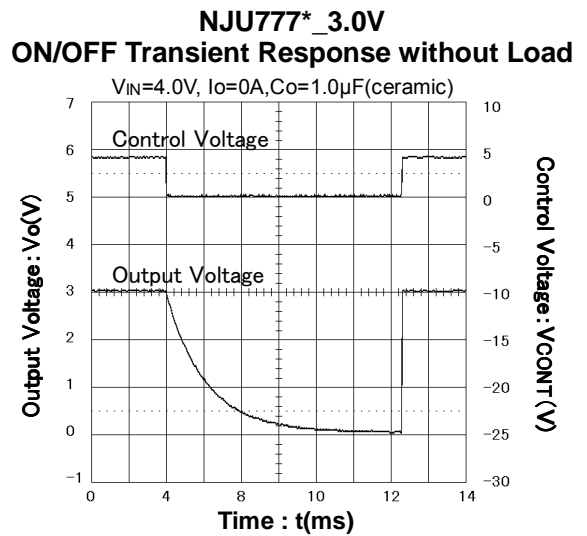
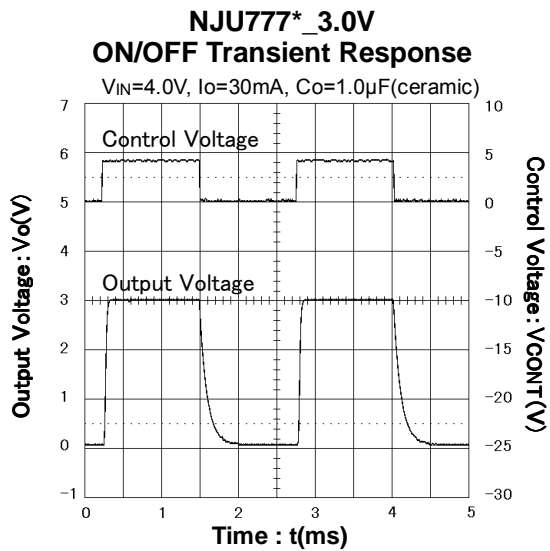

**[CAUTION]**  
The specifications on this databook are only given for information, without any guarantee as regards either mistakes or omissions. The application circuits in this databook are described only to show representative usages of the product and not intended for the guarantee or permission of any right including the industrial rights.

## X-ON Electronics

Largest Supplier of Electrical and Electronic Components

*Click to view similar products for [LDO Voltage Regulators](#) category:*

*Click to view products by [Nisshinbo](#) manufacturer:*

Other Similar products are found below :

[AP7363-SP-13](#) [L79M05TL-E](#) [PT7M8202B12TA5EX](#) [TCR3DF185,LM\(CT](#) [TCR3DF24,LM\(CT](#) [TCR3DF285,LM\(CT](#) [TCR3DF31,LM\(CT](#)  
[TCR3DF45,LM\(CT](#) [MP2013GQ-33-Z](#) [059985X](#) [NCP4687DH15T1G](#) [701326R](#) [TCR2EN28,LF\(S](#) [NCV8170AXV250T2G](#)  
[TCR3DF27,LM\(CT](#) [TCR3DF19,LM\(CT](#) [TCR3DF125,LM\(CT](#) [TCR2EN18,LF\(S](#) [AP2112R5A-3.3TRG1](#) [AP7315-25W5-7](#)  
[IFX30081LDVGRNXUMA1](#) [NCV47411PAAJR2G](#) [AP2113KTR-G1](#) [AP2111H-1.2TRG1](#) [ZLDO1117QK50TC](#) [AZ1117IH-1.8TRG1](#)  
[AZ1117ID-ADJTRG1](#) [TCR3DG12,LF](#) [MIC5514-3.3YMT-T5](#) [MIC5512-1.2YMT-T5](#) [MIC5317-2.8YM5-T5](#) [SCD7912BTG](#)  
[NCP154MX180270TAG](#) [SCD33269T-5.0G](#) [NCV8170BMX330TCG](#) [NCV8170AMX120TCG](#) [NCP706ABMX300TAG](#)  
[NCP153MX330180TCG](#) [NCP114BMX075TCG](#) [MC33269T-3.5G](#) [CAT6243-ADJCMT5T](#) [TCR3DG33,LF](#) [AP2127N-1.0TRG1](#)  
[TCR4DG35,LF](#) [LT1117CST-3.3](#) [LT1117CST-5](#) [TAR5S15U\(TE85L,F\)](#) [TAR5S18U\(TE85L,F\)](#) [TCR3UG19A,LF](#) [TCR4DG105,LF](#)