

4-Channel Electronic Volume with Input Selector

■ GENERAL DESCRIPTION

The **NJW1195A** is a 4-channel electronic volume with 4-in 2-out stereo audio selector. It performs low noise and low distortion characteristics with resistance ladder circuit.

The **NJW1195A** is also available for 2-channel differential transmission electronic volume with 2-in 1-out stereo audio selector by a differential transmission select function.

All of functions are controlled via three-wired serial bus. Selectable 4-Chip address is available for using four chips on same serial bus line.

It's suitable for two-channel stereo system and or multi-channel audio system.

At the volume attenuated, the **NJW1195A** improves low distortion compared with NJW1195. Furthermore, the **NJW1195A** supports both single power supply operation and dual power supply operation.

■ PACKAGE OUTLINE

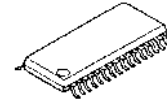

NJW1195AV

■ FEATURES

- Operating Voltage
 - Dual power supply : ± 3.5 to ± 7.5 V
 - Single power supply : $+7.0$ to $+15$ V
- 3-Wired Serial Control
- Selectable 4-Chip Address
- Low Output Noise
- Low Distortion
- 4in 2out Stereo Signal Selector
- Volume
 - +31.5 to -95dB / 0.5dB step, Mute
- Differential transmission select function
 - 120dB typ.
- Channel Separation
- Zero Cross Detection
- Bi-CMOS Technology
- Package Outline
 - SSOP32

■ BLOCK DIAGRAM

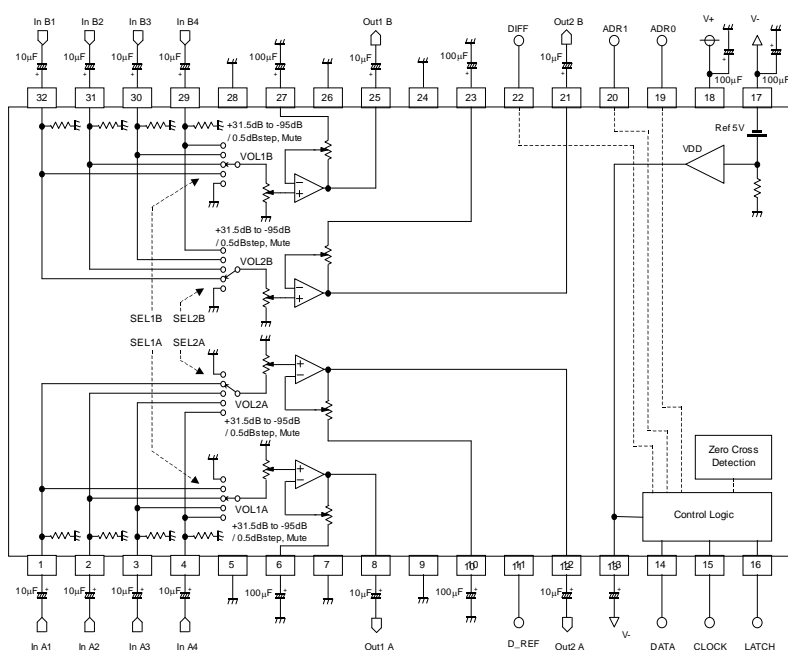

NJW1195A

■ PIN FUNCTION

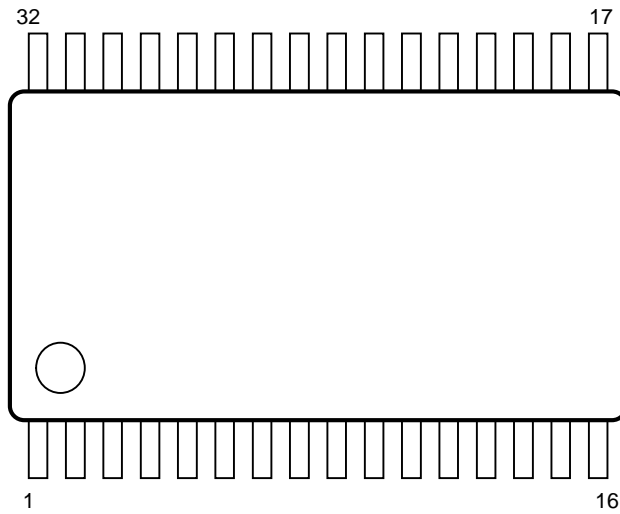

No.	SYMBOL	FUNCTION	No.	SYMBOL	FUNCTION
1	InA1	Ach Input 1	17	V -	Power Supply (-)
2	InA2	Ach Input 2	18	V+	Power Supply (+)
3	InA3	Ach Input 3	19	ADR0	Chip address setting terminal 0
4	InA4	Ach Input 4	20	ADR1	Chip address setting terminal 1
5	A_REF	Ach Reference terminal	21	Out2B	Bch 2 Output
6	DCCAP_1A	Switching noise rejection capacitor (Ach 1)	22	DIFF	Differential transmission select terminal
7	A_REF	Ach Reference terminal	23	DCCAP_2B	Switching noise rejection capacitor (Bch 2)
8	Out1A	Ach 1 Output	24	B_REF	Bch Reference terminal
9	A_REF	Ach Reference terminal	25	Out1B	Bch 1 Output
10	DCCAP_2A	Switching noise rejection capacitor (Ach 2)	26	B_REF	Bch Reference terminal
11	D_REF	Digital block Reference Voltage	27	DCCAP_1B	Switching noise rejection capacitor (Bch 1)
12	Out2A	Ach 2 Output	28	B_REF	Bch Reference terminal
13	VDDOUT	Internal Digital Power Supply output	29	InB4	Bch Input 4
14	DATA	Control data signal input	30	InB3	Bch Input 3
15	CLOCK	Clock signal input	31	InB2	Bch Input 2
16	LATCH	Latch signal input	32	InB1	Bch Input 1

■ ABSOLUTE MAXIMUM RATING (Ta=25°C)

PARAMETER	SYMBOL	RATING	UNIT
Power Supply Voltage	V ₊ /V ₋	+8/-8	V
Maximum Input Voltage	V _{IM}	V ₊ /V ₋	V
Power Dissipation	P _D	800 <small>NOTE: EIA/JEDEC STANDARD Test board (76.2x114.3x1.6mm, 2layer, FR-4) mounting</small>	mW
Operating Temperature Range	Topr	-40 ~ +85	°C
Storage Temperature Range	Tstg	-40 ~ +125	°C

■ ELECTRICAL CHARACTERISTICS (Ta=25°C, V₊/V₋=±7V, R_L=47kΩ, VOL=0dB)

PARAMETER	SYMBOL	TEST CONDITION	MIN.	TYP.	MAX.	UNIT
◆ Power Supply						
Operating Voltage	V ₊ /V ₋		± 3.5	± 7.0	± 7.5	V
Supply Current 1	I _{CC}	No signal	-	9	15	mA
Supply Current 2	I _{EE}	No signal	-	9	15	mA
◆ Input/Output Characteristics (Output)						
Maximum Output Voltage	V _{OM}	f=1kHz, THD=1% VOL=0dB	3.6	4.2	-	Vrms
Voltage Gain 1	G _{V1}	V _{IN} =2Vrms, f=1kHz VOL=0dB	-0.5	0	0.5	dB
Voltage Gain 2	G _{V2}	V _{IN} =100mVrms, f=1kHz VOL=+15dB	+14	+15	+16	dB
Voltage Gain Error 1	ΔG _{V1}	V _{IN} =2Vrms, f=1kHz VOL=0dB	-0.5	0	0.5	dB
Voltage Gain Error 2	ΔG _{V2}	f=1kHz, V _{IN} =2Vrms VOL=-60dB	-1.0	0	1.0	dB
Maximum Attenuation	A _{TT}	f=1kHz, V _{IN} =2Vrms VOL=-95dB, A-weight	-	-95	-	dB
Mute level	Mute	f=1kHz, V _{IN} =2Vrms VOL=Mute, A-weight	-	-120	-	dB
Cross Talk 1	CT1	f=1kHz, V _{IN} =2Vrms, A-weight VOL=0dB, R _g =0Ω	-	-120	-	dB
Cross Talk 2	CT2	f=20kHz, V _{IN} =2Vrms VOL=0dB, R _g =0Ω	-	-100	-	dB
Channel Separation 1	CS1	f=1kHz, V _{IN} =2Vrms, A-weight VOL=0dB, R _g =0Ω, Out1 vs. Out2	-	-120	-90	dB
Channel Separation 2	CS2	f=20kHz, V _{IN} =2Vrms VOL=0dB, R _g =0Ω, Out1 vs. Out2	-	-100	-	dB
Channel Separation 3	CS3	f=1kHz, V _{IN} =2Vrms, A-weight VOL=0dB, R _g =0Ω, Out A vs. Out B	-	-120	-90	dB
Channel Separation 4	CS4	f=20kHz, V _{IN} =2Vrms VOL=0dB, R _g =0Ω, Out A vs. Out B	-	-100	-	dB
Input Impedance *	R _{IN}	Select Channel Input Terminal	12.0	16.7	-	kΩ

* Input Impedance is reduced by half (9.1kΩ typ.) when input selector 1 (SEL1) and input selector 2 (SEL2) chose the same input.

■ ELECTRICAL CHARACTERISTICS (Ta=25°C, V⁺/V⁻=±7V, RL=47kΩ, Volume=0dB)

PARAMETER	SYMBOL	TEST CONDITION	MIN.	TYP.	MAX.	UNIT
◆ Input/Output Characteristics (Output)						
Output Noise1	V _{NO1}	Volume=0dB, Rg=0, A-weight	-	-118 (1.26μ)	-100 (10μ)	dBV (Vrms)
Output Noise2	V _{NO2}	Volume=-95dB, Rg=0, A-weight	-	-118 (1.26μ)	-	dBV (Vrms)
Total Harmonic Distortion 1	T.H.D.1	f=1kHz, V _{IN} =200mVrms, Volume=0dB, BW=400Hz-30kHz	-	0.001	-	%
Total Harmonic Distortion 2	T.H.D.2	f=10kHz, V _{IN} =200mVrms, Volume=0dB, BW=400Hz-30kHz	-	0.001	-	%
Total Harmonic Distortion 3	T.H.D.3	f=1kHz, V _{IN} =2Vrms, Volume=0dB, BW=400Hz-30kHz	-	0.001	-	%
Total Harmonic Distortion 4	T.H.D.4	f=10kHz, V _{IN} =2Vrms, Volume=0dB, BW=400Hz-30kHz	-	0.001	-	%
Total Harmonic Distortion 5	T.H.D.5	f=1kHz, V _{IN} =200mVrms, Volume=+15dB, BW=400Hz-30kHz	-	0.001	-	%
Total Harmonic Distortion 6	T.H.D.6	f=10kHz, V _{IN} =200mVrms, Volume=+15dB, BW=400Hz-30kHz	-	0.0015	-	%
Total Harmonic Distortion 7	T.H.D.7	f=1kHz, V _{IN} =2Vrms, Volume=-24dB, BW=400Hz-30kHz	-	0.003	0.01	%
Total Harmonic Distortion 8	T.H.D.8	f=10kHz, V _{IN} =2Vrms, Volume=-24dB, BW=400Hz-30kHz	-	0.003	-	%
Total Harmonic Distortion 9	T.H.D.9	f=1kHz, V _{IN} =1Vrms, Volume=0dB, BW=400Hz-30kHz, Differential transmission	-	0.0003	-	%
Total Harmonic Distortion 10	T.H.D.10	f=10kHz, V _{IN} =1Vrms, Volume=0dB, BW=400Hz-30kHz, Differential transmission	-	0.0003	-	%
◆ Logic Control Characteristics						
High Level Input Voltage	V _{IH}	DATA, CLOCK, LATCH, ADR0, ADR1, DIFF Terminal Input	2.5	-	V ⁺	V
Low Level Input Voltage	V _{IL}	DATA, CLOCK, LATCH, ADR0, ADR1, DIFF Terminal Input	0	-	1.5	V

■ TERMINAL DESCRIPTION

Terminal	SYMBOL	FUNCTION	EQUIVALENT CIRCUIT	VOLTAGE
1 2 3 4 29 30 31 32	InA1 InA2 InA3 InA4 InB4 InB3 InB2 InB1	Ach Input 1 Ach Input 2 Ach Input 3 Ach Input 4 Bch Input 4 Bch Input 3 Bch Input 2 Bch Input 1		0V
5 7 9 11 24 26 28	A_REF A_REF A_REF B_REF B_REF B_REF	Ach Reference terminal Bch Reference terminal		0V
6 10 23 27	DCCAP_1A DCCAP_2A DCCAP_2B DCCAP_1B	Switching noise rejection capacitor (Ach 1) Switching noise rejection capacitor (Ach 2) Switching noise rejection capacitor (Bch 2) Switching noise rejection capacitor (Bch 1)		0V
8 12 21 25	Out1A Out2A Out2B Out1B	Ach 1 Output Ach 2 Output Bch 2 Output Bch 1 Output		

NJW1195A

■ TERMINAL DESCRIPTION

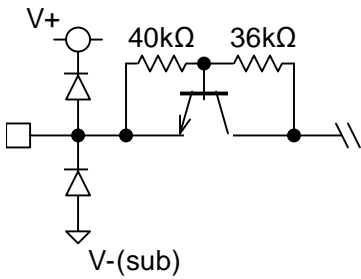
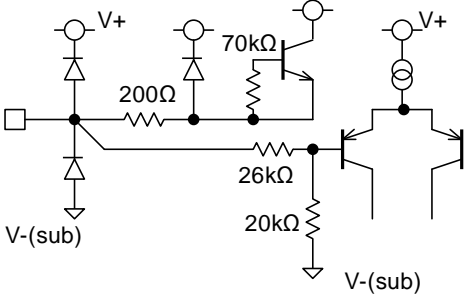
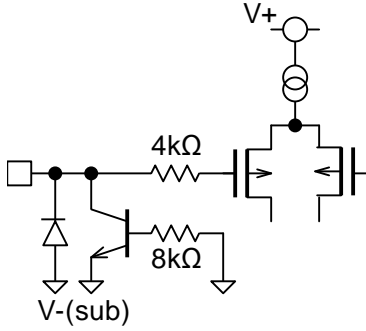
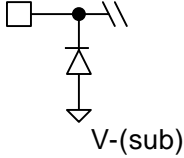
Terminal	SYMBOL	FUNCTION	EQUIVALENT CIRCUIT	VOLTAGE
11	D_REF	Digital block Reference Voltage		-
13	VDDOUT	Internal Digital Power Supply output		V-(sub) + 5V
14 15 16 19 20 22	DATA CLOCK LATCH ADR0 ADR1 DIFF	Control data signal input Clock signal input Latch signal input Chip address setting terminal 0 Chip address setting terminal 1 Differential transmission select terminal		
18	V+	Power Supply (+)		V+

■ APPLICATION CIRCUIT 1 (Dual power supply operation)

4-channel Electronic Volume with 4-input 2-output selector (DIFF : 22pin=Low)

Each selector, each volume become independent control at use by this application circuit 1 (DIFF : 22pin=Low) .

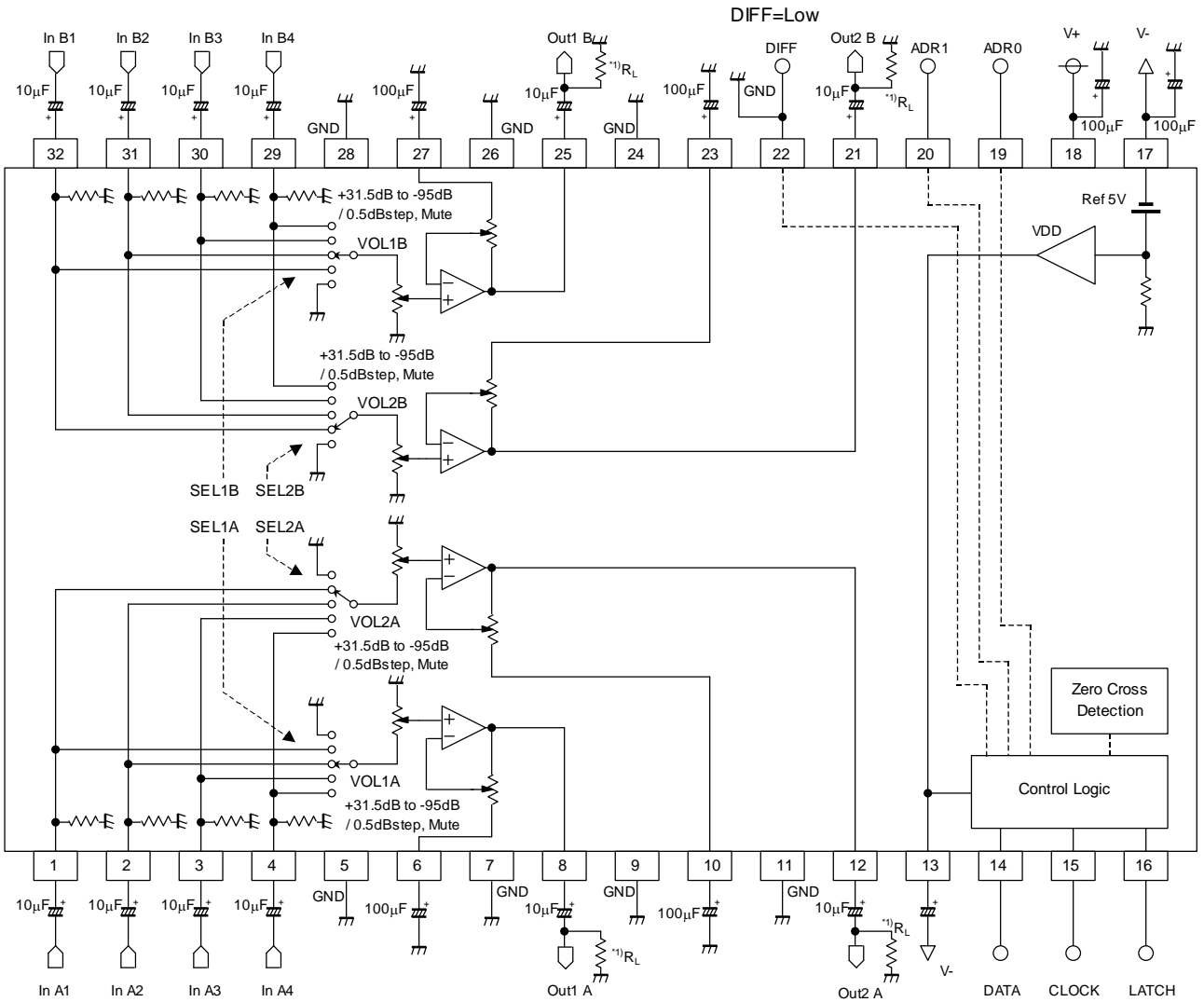

Note.1) The output terminals of this device are designed as a line driver. Use them by load resistances (RL) more than 2kΩ because output waveforms may be in an unstable condition.

APPLICATION CIRCUIT 3 (Single power supply operation)

4-channel Electronic Volume with 4-input 2-output selector (DIFF : 22pin=Low)

Each selector, each volume become independent control at use by this application circuit 1 (DIFF : 22pin=Low) .

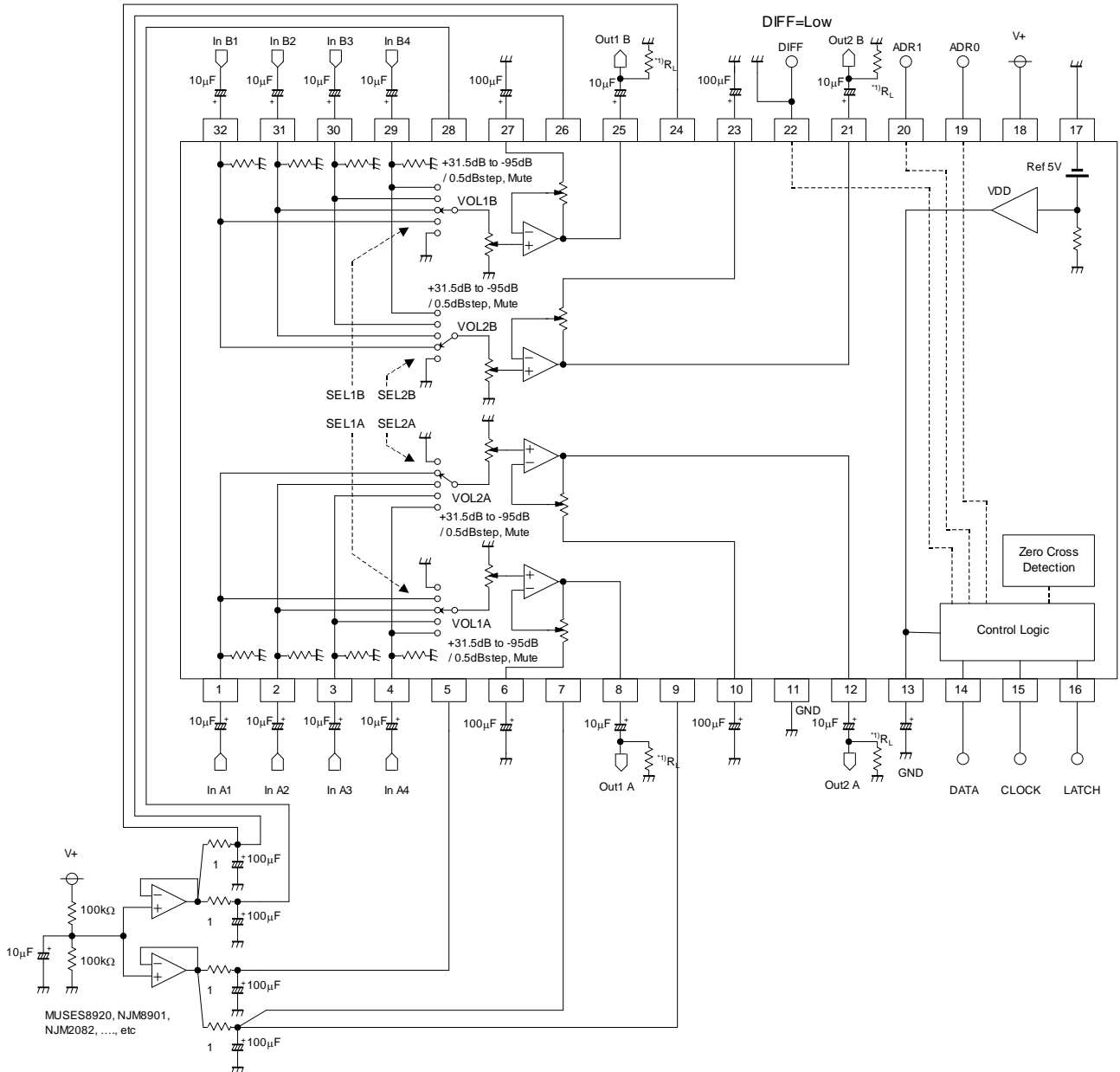

Note.1) The output terminals of this device are designed as a line driver. Use them by load resistances (RL) more than 2kΩ because output waveforms may be in an unstable condition

Note.2) Supply the reference voltage in A_REF/B_REF terminals externally in the single power supply operation. The reference voltages are recommended to be composed by one OpAmp per one channel because of keeping high channel separation. (One OpAmp is for A_REF terminal use, the other one is for B_REF terminal use.) It is effective because it prevents an oscillation of reference voltage OpAmp to use LPF such as this application

NJW1195A

APPLICATION CIRCUIT 4 (Single power supply operation)

2-channel Differential Electronic Volume with 2-input 1-output selector (DIFF : 22pin=High)

VOL1 and VOL2 is operated together on this application circuit 2 (DIFF : 22pin=High). In this case, Volume Control 1 becomes effective and does not accept Volume Control 2 about Control Data. Also, each selector becomes independent control.

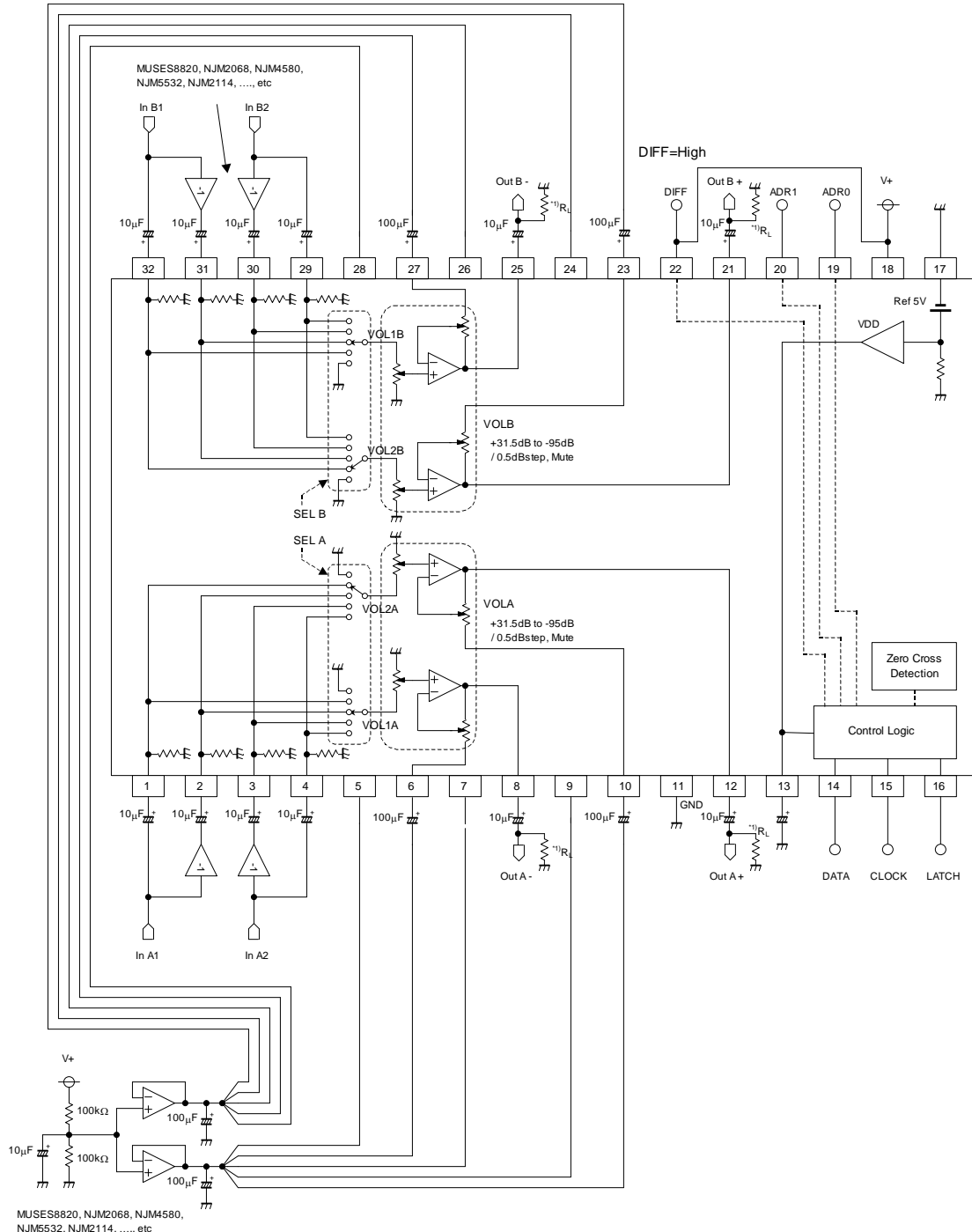

Note.1) The output terminals of this device are designed as a line driver. Use them by load resistances (RL) more than 2kΩ because output waveforms may be in an unstable condition

Note.2) Supply the reference voltage in A_REF/B_REF terminals externally in the single power supply operation. The reference voltages are recommended to be composed by one OpAmp per one channel because of keeping high channel separation. (One OpAmp is for A_REF terminal use, the other one is for B_REF terminal use.) It is effective because it prevents an oscillation of reference voltage OpAmp to use LPF such as this application

■ CONTROL DATA FORMAT

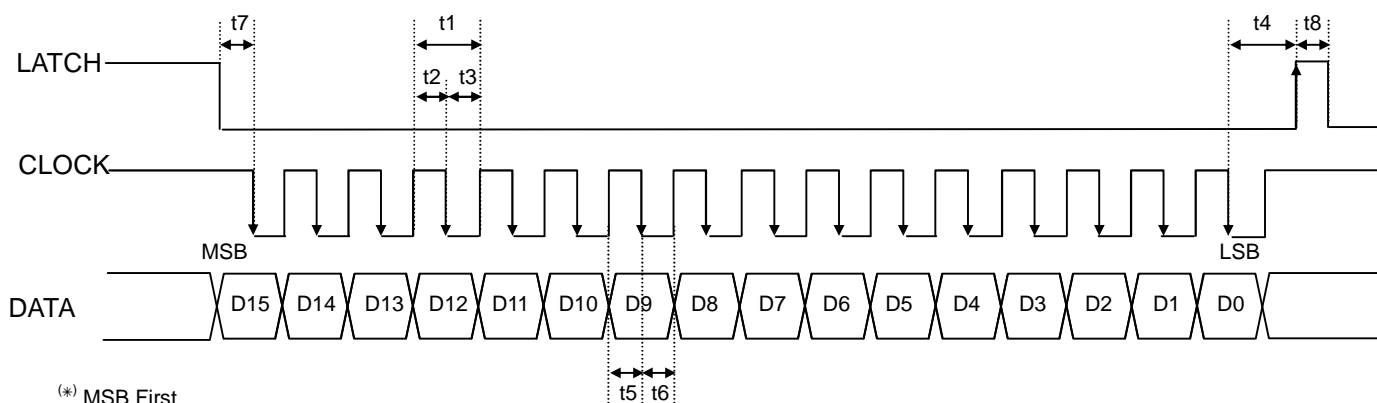

Note.) Set CLOCK in High to prevent incorrect operation during a standby period.

SYMBOL	PARAMETER	MIN	TYP	MAX	UNIT
t1	CLOCK Clock Width	4	-	-	μsec
t2	CLOCK Pulse Width (High)	2	-	-	μsec
t3	CLOCK Pulse Width (Low)	2	-	-	μsec
t4	LATCH Rise Hold Time	4	-	-	μsec
t5	DATA Setup Time	1.6	-	-	μsec
t6	DATA Hold Time	1.6	-	-	μsec
t7	CLOCK Setup Time	1.6	-	-	μsec
t8	LATCH High Pulse Width	1.6	-	-	μsec

NJW1195A

■ CONTROL DATA

NJW1195A control data is constructed with 16bits.

MSB

LSB

D15	D14	D13	D12	D11	D10	D9	D8	D7	D6	D5	D4	D3	D2	D1	D0
Data								Select Address				Chip Address			

* Control Data of Volume Control is decided by a differential transmission select terminal (DIFF : 22pin)status.

● Single transmission (DIFF : 22pin = Low)

MSB

LSB

D15	D14	D13	D12	D11	D10	D9	D8	D7	D6	D5	D4	D3	D2	D1	D0		
Volume Control 1A								0	0	0	0	*	*	*	*		
Volume Control 1B								0	0	0	1	*	*	*	*		
Volume Control 2A								0	0	1	0	*	*	*	*		
Volume Control 2B								0	0	1	1	*	*	*	*		
Input selector 1A				Input selector 2A				0	Don't Care	0	1	0	0	*	*	*	*
Input selector 1B				Input selector 2B				Don't Care	Don't Care	0	1	0	1	*	*	*	*

● Differential transmission (DIFF : 22pin = High)

MSB

LSB

D15	D14	D13	D12	D11	D10	D9	D8	D7	D6	D5	D4	D3	D2	D1	D0
Volume Control A								0	0	0	0	*	*	*	*
Volume Control B								0	0	0	1	*	*	*	*
No Acceptable								0	0	1	0	*	*	*	*
No Acceptable								0	0	1	1	*	*	*	*
Input selector A						0	Don't Care	0	1	0	0	*	*	*	*
Input selector B						Don't Care	Don't Care	0	1	0	1	*	*	*	*

* Chip address is set by chip address select terminals (ADR0, ADR1) status.

chip address select terminal		Chip Address			
ADR1 (20pin)	ADR0 (19pin)	D3	D2	D1	D0
Low	Low	0	0	0	0
Low	High	0	0	0	1
High	Low	0	0	1	0
High	High	0	0	1	1

■ INITIAL CONDITION

MSB

LSB

D15	D14	D13	D12	D11	D10	D9	D8	D7	D6	D5	D4	D3	D2	D1	D0
1	1	1	1	1	1	1	1	0	0	0	0	*	*	*	*
1	1	1	1	1	1	1	1	0	0	0	1	*	*	*	*
0	0	0	0	0	0	0	0	0	0	1	0	*	*	*	*
0	0	0	0	0	0	0	0	0	0	1	1	*	*	*	*
0	0	0	0	0	0	0	0	0	1	0	0	*	*	*	*
0	0	0	0	0	0	0	0	0	1	0	1	*	*	*	*

Note.) This product starts up by MUTE setting in power "ON". Use it after removing MUTE of each setting.

If any audio signal is inputted in input signal terminal before power "ON", it may cause initial condition abnormality.

In conditions of use such as the above, it prevents that abnormality by setting MUTE before power "OFF"

■ DEFINITION OF RESISTOR

◆Volume Control : +31.5dB to -95dB / 0.5dBstep.

D15	D14	D13	D12	D11	D10	D9	D8	D7	D6	D5	D4	D3	D2	D1	D0
Volume Control 1A								0	0	0	0	*	*	*	*
Volume Control 1B								0	0	0	1	*	*	*	*
Volume Control 2A								0	0	1	0	*	*	*	*
Volume Control 2B								0	0	1	1	*	*	*	*

< Volume Control Data >

Data								Setting
D15	D14	D13	D12	D11	D10	D9	D8	
0	0	0	0	0	0	0	0	Mute
0	0	0	0	0	0	0	1	+31.5dB
0	0	0	0	0	0	1	0	+31.0dB
0	0	0	0	0	0	1	1	+30.5dB
0	0	0	0	0	1	0	0	+30.0dB
0	0	0	0	0	1	0	1	+29.5dB
0	0	0	0	0	1	1	0	+29.0dB
0	0	0	0	0	1	1	1	+28.5dB
0	0	0	0	1	0	0	0	+28.0dB
0	0	0	0	1	0	0	1	+27.5dB
0	0	0	0	1	0	1	0	+27.0dB
0	0	0	0	1	0	1	1	+26.5dB
0	0	0	0	1	1	0	0	+26.0dB
0	0	0	0	1	1	0	1	+25.5dB
0	0	0	0	1	1	1	0	+25.0dB
0	0	0	0	1	1	1	1	+24.5dB
0	0	0	1	0	0	0	0	+24.0dB
0	0	0	1	0	0	0	1	+23.5dB
0	0	0	1	0	0	1	0	+23.0dB
0	0	0	1	0	0	1	1	+22.5dB
0	0	0	1	0	1	0	0	+22.0dB
0	0	0	1	0	1	0	1	+21.5dB
0	0	0	1	0	1	1	0	+21.0dB
0	0	0	1	0	1	1	1	+20.5dB
0	0	0	1	1	0	0	0	+20.0dB
0	0	0	1	1	0	0	1	+19.5dB
0	0	0	1	1	0	1	0	+19.0dB
0	0	0	1	1	0	1	1	+18.5dB
0	0	0	1	1	1	0	0	+18.0dB
0	0	0	1	1	1	0	1	+17.5dB
0	0	0	1	1	1	1	0	+17.0dB
0	0	0	1	1	1	1	1	+16.5dB
0	0	1	0	0	0	0	0	+16.0dB
0	0	1	0	0	0	0	1	+15.5dB
0	0	1	0	0	0	1	0	+15.0dB
0	0	1	0	0	0	1	1	+14.5dB
0	0	1	0	0	1	0	0	+14.0dB
0	0	1	0	0	1	0	1	+13.5dB
0	0	1	0	0	1	1	0	+13.0dB
0	0	1	0	0	1	1	1	+12.5dB
0	0	1	0	1	0	0	0	+12.0dB
0	0	1	0	1	0	0	1	+11.5dB
0	0	1	0	1	0	1	0	+11.0dB
0	0	1	0	1	0	1	1	+10.5dB
0	0	1	0	1	1	0	0	+10.0dB

NJW1195A

< Volume Control Data >

Data								Setting
D15	D14	D13	D12	D11	D10	D9	D8	
0	0	1	0	1	1	0	1	+9.5dB
0	0	1	0	1	1	1	0	+9.0dB
0	0	1	0	1	1	1	1	+8.5dB
0	0	1	1	0	0	0	0	+8.0dB
0	0	1	1	0	0	0	1	+7.5dB
0	0	1	1	0	0	1	0	+7.0dB
0	0	1	1	0	0	1	1	+6.5dB
0	0	1	1	0	1	0	0	+6.0dB
0	0	1	1	0	1	0	1	+5.5dB
0	0	1	1	0	1	1	0	+5.0dB
0	0	1	1	0	1	1	1	+4.5dB
0	0	1	1	1	0	0	0	+4.0dB
0	0	1	1	1	0	0	1	+3.5dB
0	0	1	1	1	0	1	0	+3.0dB
0	0	1	1	1	0	1	1	+2.5dB
0	0	1	1	1	1	0	0	+2.0dB
0	0	1	1	1	1	0	1	+1.5dB
0	0	1	1	1	1	1	0	+1.0dB
0	0	1	1	1	1	1	1	+0.5dB
0	1	0	0	0	0	0	0	0dB
0	1	0	0	0	0	0	1	-0.5dB
0	1	0	0	0	0	1	0	-1.0dB
0	1	0	0	0	0	1	1	-1.5dB
0	1	0	0	0	1	0	0	-2.0dB
0	1	0	0	0	1	0	1	-2.5dB
0	1	0	0	0	1	1	0	-3.0dB
0	1	0	0	0	1	1	1	-3.5dB
0	1	0	0	1	0	0	0	-4.0dB
0	1	0	0	1	0	0	1	-4.5dB
0	1	0	0	1	0	1	0	-5.0dB
0	1	0	0	1	0	1	1	-5.5dB
0	1	0	0	1	1	0	0	-6.0dB
0	1	0	0	1	1	0	1	-6.5dB
0	1	0	0	1	1	1	0	-7.0dB
0	1	0	0	1	1	1	1	-7.5dB
0	1	0	1	0	0	0	0	-8.0dB
0	1	0	1	0	0	0	1	-8.5dB
0	1	0	1	0	0	1	0	-9.0dB
0	1	0	1	0	0	1	1	-9.5dB
0	1	0	1	0	1	0	0	-10.0dB
0	1	0	1	0	1	0	1	-10.5dB
0	1	0	1	0	1	1	0	-11.0dB
0	1	0	1	0	1	1	1	-11.5dB
0	1	0	1	1	0	0	0	-12.0dB
0	1	0	1	1	0	0	1	-12.5dB
0	1	0	1	1	0	1	0	-13.0dB
0	1	0	1	1	0	1	1	-13.5dB
0	1	0	1	1	1	0	0	-14.0dB
0	1	0	1	1	1	0	1	-14.5dB
0	1	0	1	1	1	1	0	-15.0dB
0	1	0	1	1	1	1	1	-15.5dB
0	1	1	0	0	0	0	0	-16.0dB
0	1	1	0	0	0	0	1	-16.5dB
0	1	1	0	0	0	1	0	-17.0dB
0	1	1	0	0	0	1	1	-17.5dB
0	1	1	0	0	1	0	0	-18.0dB
0	1	1	0	0	1	0	1	-18.5dB
0	1	1	0	0	1	1	0	-19.0dB

< Volume Control Data >

Data								Setting
D15	D14	D13	D12	D11	D10	D9	D8	
0	1	1	0	0	1	1	1	-19.5dB
0	1	1	0	1	0	0	0	-20.0dB
0	1	1	0	1	0	0	1	-20.5dB
0	1	1	0	1	0	1	0	-21.0dB
0	1	1	0	1	0	1	1	-21.5dB
0	1	1	0	1	1	0	0	-22.0dB
0	1	1	0	1	1	0	1	-22.5dB
0	1	1	0	1	1	1	0	-23.0dB
0	1	1	0	1	1	1	1	-23.5dB
0	1	1	1	0	0	0	0	-24.0dB
0	1	1	1	0	0	0	1	-24.5dB
0	1	1	1	0	0	1	0	-25.0dB
0	1	1	1	0	0	1	1	-25.5dB
0	1	1	1	0	1	0	0	-26.0dB
0	1	1	1	0	1	0	1	-26.5dB
0	1	1	1	0	1	1	0	-27.0dB
0	1	1	1	0	1	1	1	-27.5dB
0	1	1	1	1	0	0	0	-28.0dB
0	1	1	1	1	0	0	1	-28.5dB
0	1	1	1	1	0	1	0	-29.0dB
0	1	1	1	1	0	1	1	-29.5dB
0	1	1	1	1	1	0	0	-30.0dB
0	1	1	1	1	1	0	1	-30.5dB
0	1	1	1	1	1	1	0	-31.0dB
0	1	1	1	1	1	1	1	-31.5dB
1	0	0	0	0	0	0	0	-32.0dB
1	0	0	0	0	0	0	1	-32.5dB
1	0	0	0	0	0	1	0	-33.0dB
1	0	0	0	0	0	1	1	-33.5dB
1	0	0	0	0	1	0	0	-34.0dB
1	0	0	0	0	1	0	1	-34.5dB
1	0	0	0	0	1	1	0	-35.0dB
1	0	0	0	0	1	1	1	-35.5dB
1	0	0	0	1	0	0	0	-36.0dB
1	0	0	0	1	0	0	1	-36.5dB
1	0	0	0	1	0	1	0	-37.0dB
1	0	0	0	1	0	1	1	-37.5dB
1	0	0	0	1	1	0	0	-38.0dB
1	0	0	0	1	1	0	1	-38.5dB
1	0	0	0	1	1	1	0	-39.0dB
1	0	0	0	1	1	1	1	-39.5dB
1	0	0	1	0	0	0	0	-40.0dB
1	0	0	1	0	0	0	1	-40.5dB
1	0	0	1	0	0	1	0	-41.0dB
1	0	0	1	0	0	1	1	-41.5dB
1	0	0	1	0	1	0	0	-42.0dB
1	0	0	1	0	1	0	1	-42.5dB
1	0	0	1	0	1	1	0	-43.0dB
1	0	0	1	0	1	1	1	-43.5dB
1	0	0	1	1	0	0	0	-44.0dB
1	0	0	1	1	0	0	1	-44.5dB
1	0	0	1	1	0	1	0	-45.0dB
1	0	0	1	1	0	1	1	-45.5dB
1	0	0	1	1	1	0	0	-46.0dB
1	0	0	1	1	1	0	1	-46.5dB
1	0	0	1	1	1	1	0	-47.0dB
1	0	0	1	1	1	1	1	-47.5dB
1	0	1	0	0	0	0	0	-48.0dB

NJW1195A

< Volume Control Data >

Data								Setting
D15	D14	D13	D12	D11	D10	D9	D8	
1	0	1	0	0	0	0	1	-48.5dB
1	0	1	0	0	0	1	0	-49.0dB
1	0	1	0	0	0	1	1	-49.5dB
1	0	1	0	0	1	0	0	-50.0dB
1	0	1	0	0	1	0	1	-50.5dB
1	0	1	0	0	1	1	0	-51.0dB
1	0	1	0	0	1	1	1	-51.5dB
1	0	1	0	1	0	0	0	-52.0dB
1	0	1	0	1	0	0	1	-52.5dB
1	0	1	0	1	0	1	0	-53.0dB
1	0	1	0	1	0	1	1	-53.5dB
1	0	1	0	1	1	0	0	-54.0dB
1	0	1	0	1	1	0	1	-54.5dB
1	0	1	0	1	1	1	0	-55.0dB
1	0	1	0	1	1	1	1	-55.5dB
1	0	1	1	0	0	0	0	-56.0dB
1	0	1	1	0	0	0	1	-56.5dB
1	0	1	1	0	0	1	0	-57.0dB
1	0	1	1	0	0	1	1	-57.5dB
1	0	1	1	0	1	0	0	-58.0dB
1	0	1	1	0	1	0	1	-58.5dB
1	0	1	1	0	1	1	0	-59.0dB
1	0	1	1	0	1	1	1	-59.5dB
1	0	1	1	1	0	0	0	-60.0dB
1	0	1	1	1	0	0	1	-60.5dB
1	0	1	1	1	0	1	0	-61.0dB
1	0	1	1	1	0	1	1	-61.5dB
1	0	1	1	1	1	0	0	-62.0dB
1	0	1	1	1	1	0	1	-62.5dB
1	0	1	1	1	1	1	0	-63.0dB
1	0	1	1	1	1	1	1	-63.5dB
1	1	0	0	0	0	0	0	-64.0dB
1	1	0	0	0	0	0	1	-64.5dB
1	1	0	0	0	0	1	0	-65.0dB
1	1	0	0	0	0	1	1	-65.5dB
1	1	0	0	0	1	0	0	-66.0dB
1	1	0	0	0	1	0	1	-66.5dB
1	1	0	0	0	1	1	0	-67.0dB
1	1	0	0	0	1	1	1	-67.5dB
1	1	0	0	1	0	0	0	-68.0dB
1	1	0	0	1	0	0	1	-68.5dB
1	1	0	0	1	0	1	0	-69.0dB
1	1	0	0	1	0	1	1	-69.5dB
1	1	0	0	1	1	0	0	-70.0dB
1	1	0	0	1	1	0	1	-70.5dB
1	1	0	0	1	1	1	0	-71.0dB
1	1	0	0	1	1	1	1	-71.5dB
1	1	0	1	0	0	0	0	-72.0dB
1	1	0	1	0	0	0	1	-72.5dB
1	1	0	1	0	0	1	0	-73.0dB
1	1	0	1	0	0	1	1	-73.5dB
1	1	0	1	0	1	0	0	-74.0dB
1	1	0	1	0	1	0	1	-74.5dB
1	1	0	1	0	1	1	0	-75.0dB
1	1	0	1	0	1	1	1	-75.5dB
1	1	0	1	1	0	0	0	-76.0dB
1	1	0	1	1	0	0	1	-76.5dB
1	1	0	1	1	0	1	0	-77.0dB

< Volume Control Data >

Data								Setting
D15	D14	D13	D12	D11	D10	D9	D8	
1	1	0	1	1	0	1	1	-77.5dB
1	1	0	1	1	1	0	0	-78.0dB
1	1	0	1	1	1	0	1	-78.5dB
1	1	0	1	1	1	1	0	-79.0dB
1	1	0	1	1	1	1	1	-79.5dB
1	1	1	0	0	0	0	0	-80.0dB
1	1	1	0	0	0	0	1	-80.5dB
1	1	1	0	0	0	1	0	-81.0dB
1	1	1	0	0	0	1	1	-81.5dB
1	1	1	0	0	1	0	0	-82.0dB
1	1	1	0	0	1	0	1	-82.5dB
1	1	1	0	0	1	1	0	-83.0dB
1	1	1	0	0	1	1	1	-83.5dB
1	1	1	0	1	0	0	0	-84.0dB
1	1	1	0	1	0	0	1	-84.5dB
1	1	1	0	1	0	1	0	-85.0dB
1	1	1	0	1	0	1	1	-85.5dB
1	1	1	0	1	1	0	0	-86.0dB
1	1	1	0	1	1	0	1	-86.5dB
1	1	1	0	1	1	1	0	-87.0dB
1	1	1	0	1	1	1	1	-87.5dB
1	1	1	1	0	0	0	0	-88.0dB
1	1	1	1	0	0	0	1	-88.5dB
1	1	1	1	0	0	1	0	-89.0dB
1	1	1	1	0	0	1	1	-89.5dB
1	1	1	1	0	1	0	0	-90.0dB
1	1	1	1	0	1	0	1	-90.5dB
1	1	1	1	0	1	1	0	-91.0dB
1	1	1	1	0	1	1	1	-91.5dB
1	1	1	1	1	0	0	0	-92.0dB
1	1	1	1	1	0	0	1	-92.5dB
1	1	1	1	1	0	1	0	-93.0dB
1	1	1	1	1	0	1	1	-93.5dB
1	1	1	1	1	1	0	0	-94.0dB
1	1	1	1	1	1	0	1	-94.5dB
1	1	1	1	1	1	1	0	-95.0dB
1	1	1	1	1	1	1	1	Mute ^(*)

(*)Initial Setting

● Single transmission (DIFF : 22pin = Low)

Note) Setting-example on application circuit 1, 3

◆ **Input Selector**

: Selector for the single-end inputs from 1IN to 4IN

D15	D14	D13	D12	D11	D10	D9	D8	D7	D6	D5	D4	D3	D2	D1	D0
Input Selector 1A			Input Selector 2A			0	Don't Care	0	1	0	0	*	*	*	*
Input Selector 1B			Input Selector 2B			Don't Care	Don't Care	0	1	0	1	*	*	*	*

< Input Selector Data >

Data			Setting
D15	D14	D13	
D12	D11	D10	
0	0	0	Mute ^(*)
0	0	1	Input1
0	1	0	Input2
0	1	1	Input3
1	0	0	Input4

^(*)Initial Setting

Note) Input Impedance is reduced by half (TBDkΩ typ.) when input selector 1 (SEL1) and Input selector 2 (SEL2) chose the same input.

● Differential transmission (DIFF : 22pin = High)

Note) Setting-example on application circuit 2, 4

◆ **Input Selector**

: Selector for the differential inputs from 1IN to 2IN

D15	D14	D13	D12	D11	D10	D9	D8	D7	D6	D5	D4	D3	D2	D1	D0
Input Selector A						0	Don't Care	0	1	0	0	*	*	*	*
Input Selector B						Don't Care	Don't Care	0	1	0	1	*	*	*	*

< Input Selector Data >

Data						Setting
D15	D14	D13	D12	D11	D10	
0	0	0	0	0	0	Mute ^(*)
0	1	0	0	0	1	Input1
0	1	1	1	0	0	Input2

^(*)Initial Setting

TYPICAL CHARACTERISTICS

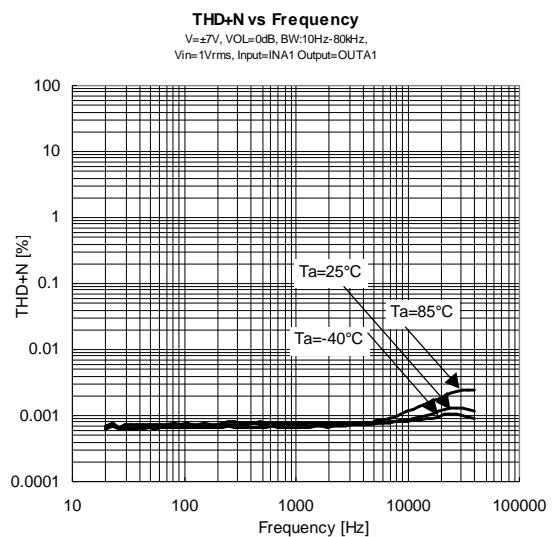
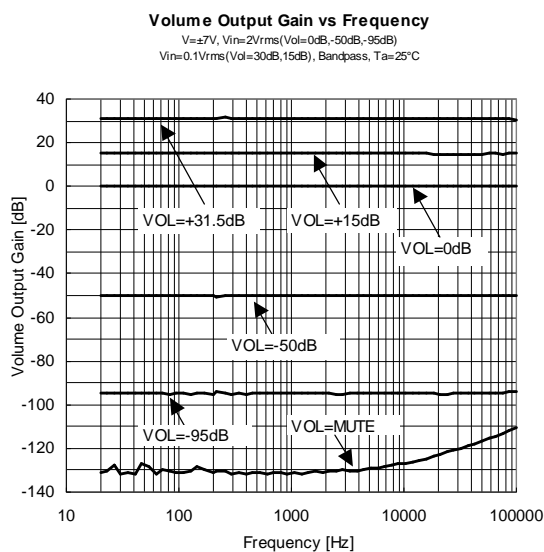
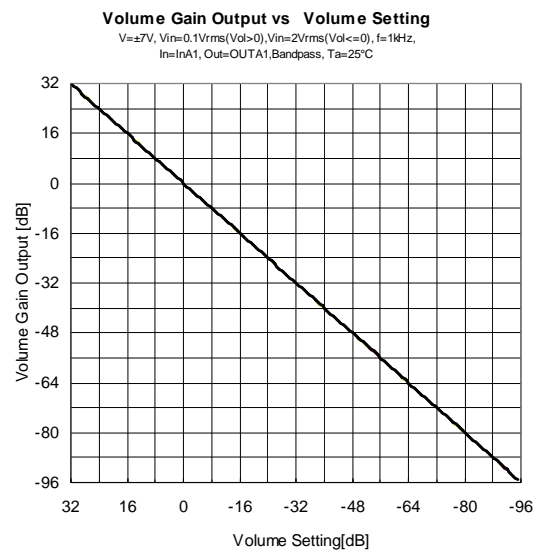
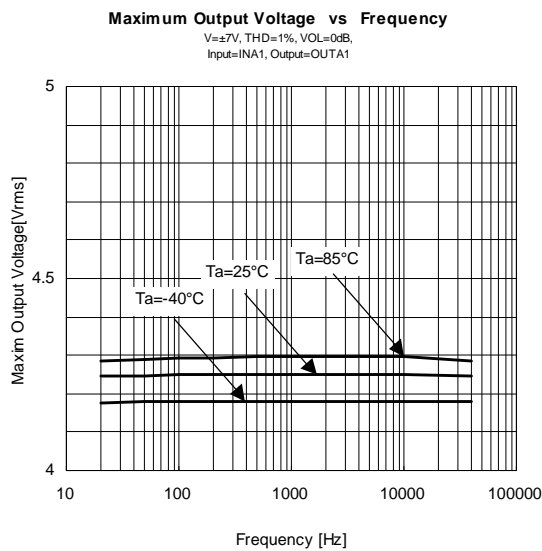
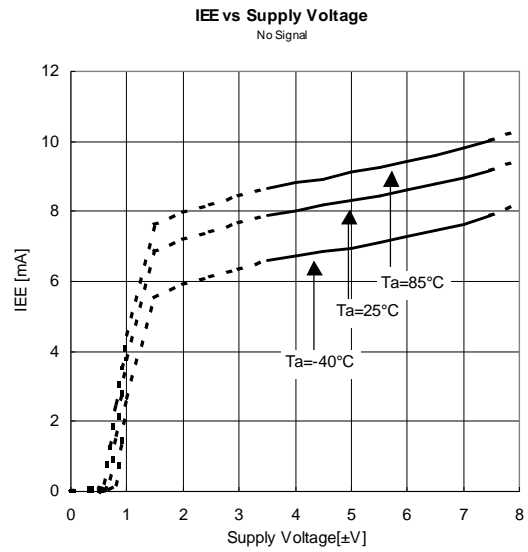
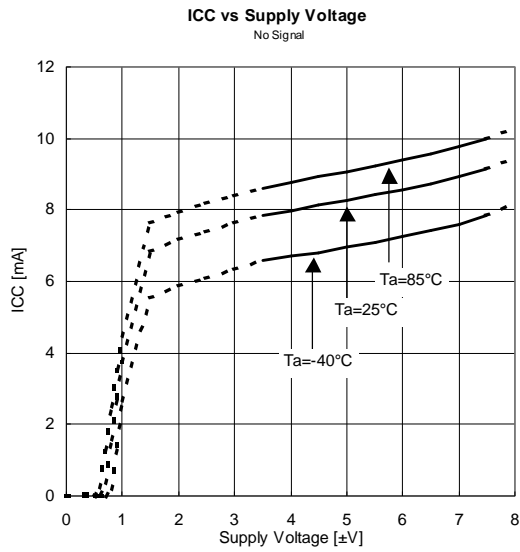

TYPICAL CHARACTERISTICS

THD+N vs Input Voltage

V=z7V, VOL=0dB, Input=INA1, Output=OUTA1,
 BW:10Hz-22kHz (f=100Hz), 400Hz-30kHz (f=1kHz),
 400Hz-80kHz (f=10kHz), Ta=25°C

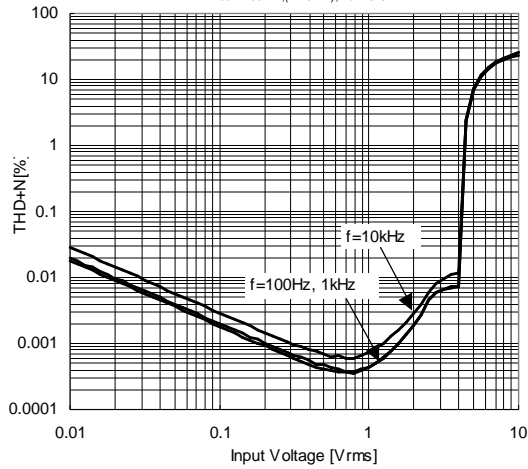

THD+N vs Input Voltage

V=z7V, f=1kHz, Vin=1Vrms, Input=INA1, Output=OUTA1
 BW:400Hz-30kHz, Ta=25°C

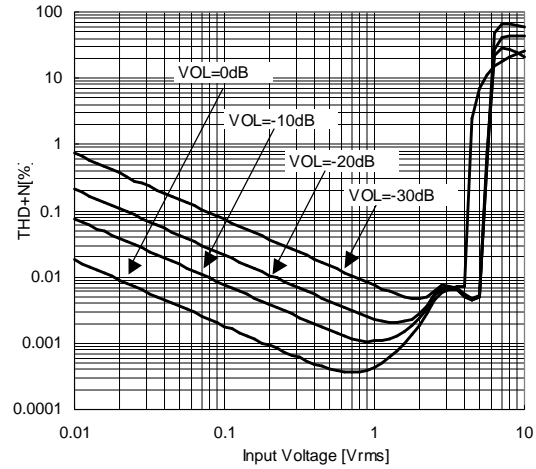

Channel Separation vs Frequency

V=z7V, Vin=2Vrms, VOL=0dB, Input=INB1,
 Output=OUTA1, BW=10Hz-80kHz, Ta=25°C

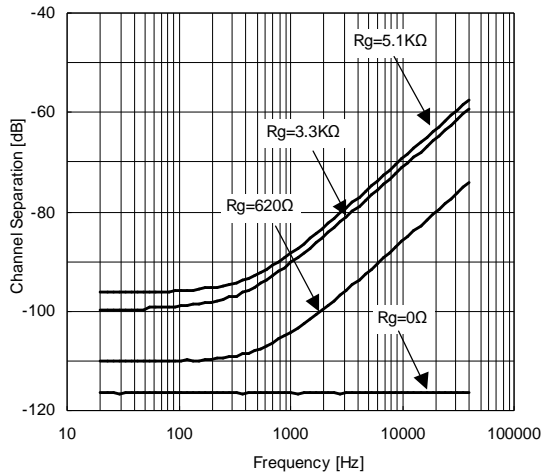

Cross Talk vs Frequency

V=z7V, Vin=2Vrms, VOL=0dB, Input=INA2-INA4,
 Output=OUTA1, Select Channel=Input1
 BW=10Hz-80kHz, Ta=25°C

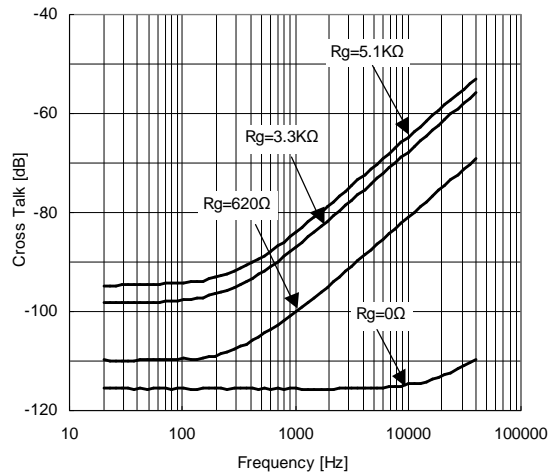

[CAUTION]

The specifications on this databook are only given for information, without any guarantee as regards either mistakes or omissions. The application circuits in this databook are described only to show representative usages of the product and not intended for the guarantee or permission of any right including the industrial rights.

X-ON Electronics

Largest Supplier of Electrical and Electronic Components

Click to view similar products for [Audio DSPs](#) category:

Click to view products by [Nisshinbo](#) manufacturer:

Other Similar products are found below :

[AT85C51SND3B1-RTTUL](#) [BR281W31A101V1G](#) [CS47048C-CQZR](#) [MAX9892ERT+T](#) [SB3231-E1](#) [HMC1022-SX](#) [SA3229-E1-T](#)
[LC75056PE-H](#) [IA8201-RDI-01](#) [R3710-CEAA-E1](#) [HMC5622LS7TR](#) [TAS3204PAGR](#) [LC823450TA-2H](#) [LC823450XDTBG](#) [ZL38052LDG1](#)
[ADAV4601BSTZ](#) [AD1954YSTZ](#) [ADAU1701JSTZ-RL](#) [AD1940YSTZ](#) [ADAU1702JSTZ](#) [PT2399](#) [XD567](#) [XD1881](#) [TDA7440D013TR](#)
[LM4863G-N20-R](#) [IA8201CQ](#) [SPK2611HM7H-1-2](#) [CM108B](#) [CM118B](#) [HS-100B](#) [CM108AH](#) [S1V30120F01A100](#) [CMX138AE1](#)
[LC786820E-6E03-3H](#) [DSPB56720AG](#) [LC823455XATBG](#) [ZL38060LDG1](#) [BD37033FV-ME2](#) [BM28720MUV-E2](#) [WT588H-16S](#) [WT588S-](#)
[16S](#) [MC34118D](#) [BD3702FV-E2](#) [TEA1062NG-S16-R](#) [TM2313](#) [CD2399](#) [PT2314E](#) [PT2259-S](#) [PT7313E](#) [PT2399-SN](#)