

## 45V $I_o=200\text{mA}$ Ultra low Quiescent current LDO

### FEATURES

- Low Quiescent Current       $5.5\mu\text{A}$  typ.(A version)  
    $5.0\mu\text{A}$  typ.(B version)
- Operating Voltage            4.0V to 40V
- Operating Temperature       $T_a=-40^\circ\text{C}$  to  $125^\circ\text{C}$
- Output Voltage Accuracy     $V_o \pm 1.0\%$ ( $T_a=25^\circ\text{C}$ )  
    $V_o \pm 2.0\%$ ( $T_a=-40^\circ\text{C}$  to  $125^\circ\text{C}$ )
- Output Current                 $I_o(\text{min.})=200\text{mA}$
- ON/OFF Control                A ver. only
- Correspond to MLCC
- Under Voltage Lock Out circuit
- Thermal Shutdown Circuit
- Over Current Protection Circuit
- Package Outline                A ver. SOT-89-5-2  
   B ver. SOT-89-3, TO-252-3-L1

### GENERAL DESCRIPTION

NJW4104 is a 45V  $I_o=200\text{mA}$  ultra low quiescent current low dropout regulator.

It achieves low quiescent current characteristics, therefore it contributes to reduce current consumption of applications.

Output Voltage is guaranteed  $\pm 2\%$  under wide range conditions:  $V_{IN}=V_o+1\text{V}$  to  $40\text{V}$ ,  $I_o=0$  to  $200\text{mA}$  and  $T_a=-40^\circ\text{C}$  to  $125^\circ\text{C}$ .

Because of wide input voltage range and wide operating temperature range, the NJW4104 is suitable for various applications including automotive applications.

### APPLICATION

- Automotive infotainment
- Automotive ECU unit
- Industrial equipment

### TYPICAL APPLICATION

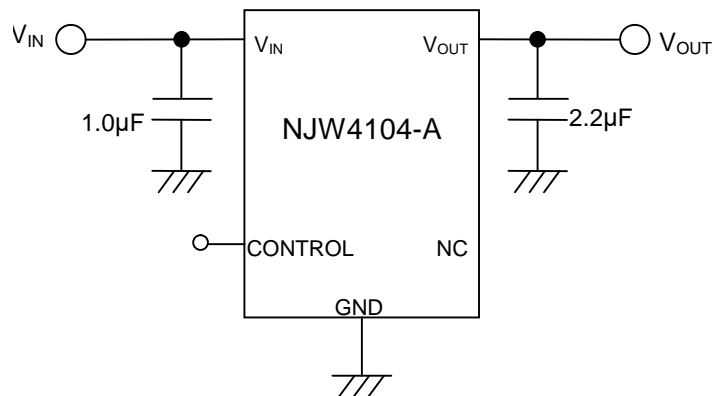

### BLOCK DIAGRAM

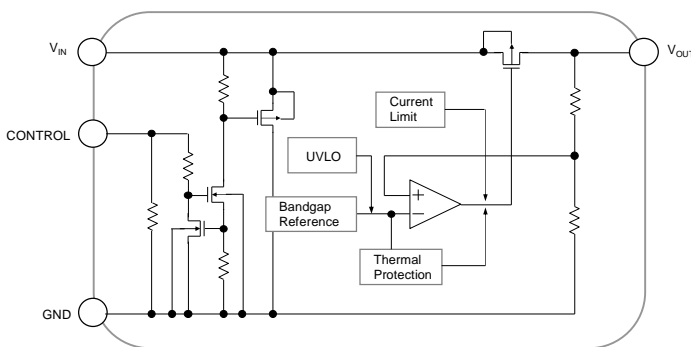

A version

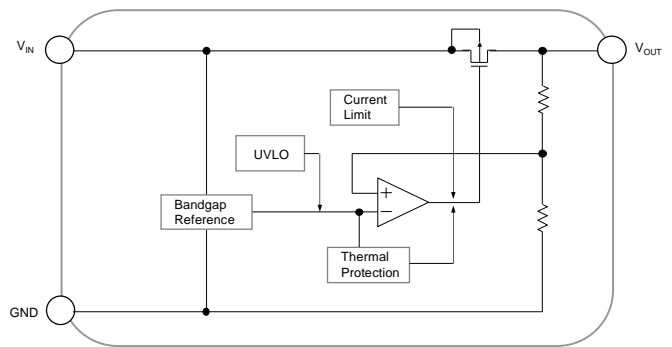

B version

## ■OUTPUT VOLTAGE RANK

SOT-89-5-2

SOT-89-3

TO-252-3-L1

PART NUMBER	OUTPUT VOLTAGE	PART NUMBER	OUTPUT VOLTAGE	PART NUMBER	OUTPUT VOLTAGE
NJW4104U2-33A / -T1	3.3V	NJW4104U3-33B / -T1	3.3V	NJW4104DL1-33B	3.3V
NJW4104U2-05A / -T1	5.0V	NJW4104U3-05B / -T1	5.0V	NJW4104DL1-05B	5.0V

## ■PIN CONFIGURATION

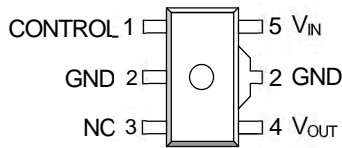

SOT-89-5-2

PIN NO.	SYMBOL	DESCRIPTION
1	CONTROL	ON/OFF Control
2	GND	Ground
3	NC	No Connection*
4	V <sub>OUT</sub>	Output
5	V <sub>IN</sub>	Input

\*Note) NC pin is not connect to internally circuit. This pin can be open or connected to ground. Connecting to ground is recommended to improve thermal dissipation.

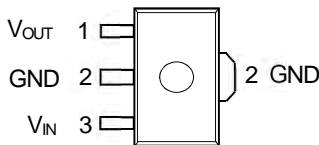

SOT-89-3

PIN NO.	SYMBOL	DESCRIPTION
1	V <sub>OUT</sub>	Output
2	GND	Ground
3	V <sub>IN</sub>	Input

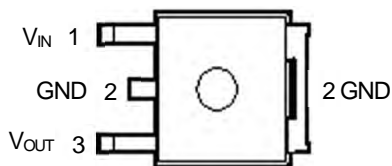

TO-252-3-L1

PIN NO.	SYMBOL	DESCRIPTION
1	V <sub>IN</sub>	Input
2	GND	Ground
3	V <sub>OUT</sub>	Output

## ■PRODUCT NAME INFORMATION

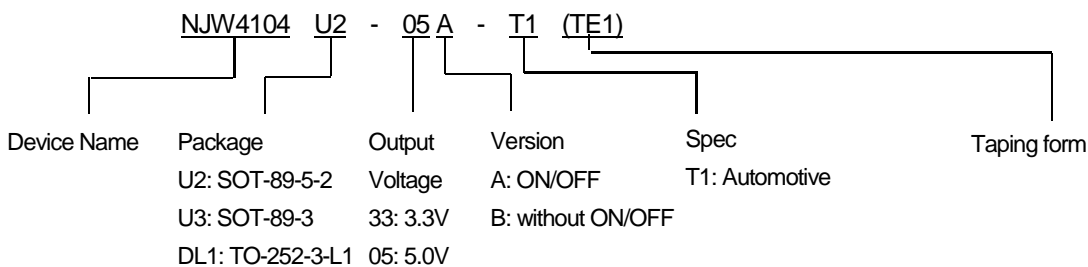

## ■ORDERING INFORMATION

PRODUCT NAME	OUTPUT VOLTAGE	PACKAGE OUTLINE	AUTOMOTIVE SPEC	RoHS	HALOGEN-FREE	TERMINAL FINISH	MARKING	WEIGHT (mg)	MOQ (pcs)
NJW4104U2-33A(TE1)	3.3V	SOT-89-5-2		yes	yes	Sn-2Bi	231	61	1000
NJW4104U2-05A(TE1)	5.0V	SOT-89-5-2		yes	yes	Sn-2Bi	241	61	1000
NJW4104U2-33A-T1(TE1)	3.3V	SOT-89-5-2	yes	yes	yes	Sn-2Bi	251	61	1000
NJW4104U2-05A-T1(TE1)	5.0V	SOT-89-5-2	yes	yes	yes	Sn-2Bi	261	61	1000
NJW4104U3-33B(TE1)	3.3V	SOT-89-3		yes	yes	Sn-2Bi	001	61	1000
NJW4104U3-05B(TE1)	5.0V	SOT-89-3		yes	yes	Sn-2Bi	011	61	1000
NJW4104U3-33B-T1(TE1)	3.3V	SOT-89-3	yes	yes	yes	Sn-2Bi	021	61	1000
NJW4104U3-05B-T1(TE1)	5.0V	SOT-89-3	yes	yes	yes	Sn-2Bi	031	61	1000
NJW4104DL1-33B(TE1)	3.3V	TO-252-3-L1		yes	yes	Sn-2Bi	04B33	301	3000
NJW4104DL1-05B(TE1)	5.0V	TO-252-3-L1		yes	yes	Sn-2Bi	04B05	301	3000

Note) "-" is non-evaluation. Please contact your sales representative for more information.

## ■ABSOLUTE MAXIMUM RATINGS

PARAMETER	SYMBOL	RATINGS	UNIT
Input Voltage	$V_{IN}$	-0.3 to +45	V
Control Pin Voltage <sup>(1)</sup>	$V_{CONT}$	-0.3 to +45	V
Output Voltage	$V_{OUT}$	-0.3 to $V_{IN} \leq +17$	V
Power Dissipation( $T_a=25^\circ\text{C}$ )	$P_D$	(2-layer / 4-layer)	mW
SOT-89		625 <sup>(2)</sup> / 2400 <sup>(3)</sup>	
TO-252		1190 <sup>(2)</sup> / 3125 <sup>(3)</sup>	
Junction Temperature Range	$T_j$	-40 to +150	$^\circ\text{C}$
Operating Temperature Range	$T_{opr}$	-40 to +125	$^\circ\text{C}$
Storage Temperature Range	$T_{stg}$	-50 to +150	$^\circ\text{C}$

(1): Applied for A version.

(2): Mounted on glass epoxy board. (76.2×114.3×1.6mm: based on EIA/JEDEC standard, 2Layers)

(3): Mounted on glass epoxy board. (76.2×114.3×1.6mm: based on EIA/JEDEC standard, 4Layers), internal Cu area: 74.2x74.2mm  
(For 4Layers :Applying 74.2 x 74.2mm inner Cu area and thermal via holes to board based on JEDEC standard JESD51-5)

## ■RECOMMENDED OPERATING CONDITIONS

PARAMETER	SYMBOL	VALUE	UNIT
Operating Voltage Range	$V_{IN}$	4.0 to 40	V
Control Voltage	$V_{CONT}$	0 to 40	V

**■ELECTRICAL CHARACTERISTICS**

 Unless other noted,  $V_{IN} = V_O + 1V$ ,  $C_{IN} = 1.0\mu F$ ,  $C_O = 2.2\mu F$ ,  $T_a = 25^\circ C$ 

PARAMETER	SYMBOL	TEST CONDITION	MIN.	TYP.	MAX.	単位	
Output Voltage	$V_O$	$V_{IN} = V_O + 1V$ to 40V, $I_O = 0mA$ to 200mA,	-1.0%	-	+1.0%	V	
		$V_{IN} = V_O + 1V$ to 40V, $I_O = 0mA$ to 200mA, $T_a = -40^\circ C$ to $+125^\circ C$	-2.0%	-	+2.0%		
Quiescent Current	$I_Q$	A version, $I_O = 0mA$ , except $I_{CONT}$	-	5.5	9.5	$\mu A$	
		A version, $I_O = 0mA$ , except $I_{CONT}$ , $T_a = -40^\circ C$ to $+125^\circ C$	-	-	13.5		
		B version, $I_O = 0mA$	-	5.0	8.5		
		B version, $I_O = 0mA$ , $T_a = -40^\circ C$ to $+125^\circ C$	-	-	12		
Quiescent Current at Control OFF <sup>(4)</sup>	$I_{Q(OFF)}$	$V_{CONT} = 0V$	-	-	1	$\mu A$	
		$V_{CONT} = 0V$ , $T_a = -40^\circ C$ to $+125^\circ C$	-	-	1		
Output Current	$I_O$	$V_O \times 0.9$	200	-	-	mA	
		$V_O \times 0.9$ , $T_a = -40^\circ C$ to $+125^\circ C$	200	-	-		
Line Regulation	$\Delta V_O / \Delta V_{IN}$	$V_{IN} = V_O + 1V$ to 40V, $I_O = 30mA$	$V_O = 3.3V$	-	-	23.5	mV
			$V_O = 5.0V$	-	-	34	
		$V_{IN} = V_O + 1V$ to 40V, $I_O = 30mA$ , $T_a = -40^\circ C$ to $+125^\circ C$	$V_O = 3.3V$	-	-	35.3	
			$V_O = 5.0V$	-	-	51	
Load Regulation	$\Delta V_O / \Delta I_O$	$I_O = 0mA$ to 200mA	$V_O = 3.3V$	-	-	15.2	mV
			$V_O = 5.0V$	-	-	23	
		$I_O = 0mA$ to 200mA, $T_a = -40^\circ C$ to $+125^\circ C$	$V_O = 3.3V$	-	-	26.4	
			$V_O = 5.0V$	-	-	40	
Ripple Rejection	RR	$V_{IN} = 7.0V$ , $e_{in} = 200mV_{rms}$ , $f = 1kHz$ , $I_O = 10mA$	$V_O = 3.3V$	-	41	-	dB
			$V_O = 5.0V$	-	36	-	
Dropout Voltage <sup>(5)</sup>	$\Delta V_{IO}$	$I_O = 100mA$	-	0.18	0.25	V	
		$I_O = 100mA$ , $T_a = -40^\circ C$ to $+125^\circ C$	-	-	0.46		
Control Current <sup>(4)</sup>	$I_{CONT}$	$V_{CONT} = 1.6V$	-	0.5	2	$\mu A$	
		$V_{CONT} = 1.8V$ , $T_a = -40^\circ C$ to $+125^\circ C$	-	-	3		
Control Voltage for ON-state <sup>(4)</sup>	$V_{CONT(ON)}$		1.6	-	-	V	
		$T_a = -40^\circ C$ to $+125^\circ C$	1.8	-	-		
Control Voltage for OFF-state <sup>(4)</sup>	$V_{CONT(OFF)}$		-	-	0.6	V	
		$T_a = -40^\circ C$ to $+125^\circ C$	-	-	0.6		
UVLO Release Voltage	$V_{UVLO}$	$V_{IN} = L$ H	2.4	2.8	3.3	V	
		$V_{IN} = L$ H, $T_a = -40^\circ C$ to $+125^\circ C$	2.1	-	3.5		
UVLO Hysteresis Voltage	$V_{HYS}$	$V_{IN} = H$ L	70	200	-	mV	
		$V_{IN} = H$ L, $T_a = -40^\circ C$ to $+125^\circ C$	70	-	-		
Average Temperature Coefficient of Output Voltage	$\Delta V_O / \Delta T_a$	$T_a = -40^\circ C$ to $125^\circ C$ , $I_O = 30mA$	-	$\pm 50$	-	ppm/ $^\circ C$	

(4): Applied for A version.

(5): Except Output Voltage Rank less than 3.8V

 Characteristics values of defined as  $T_a = -40^\circ C$  to  $+125^\circ C$  are applied only "T1" spec.

## ■ THERMAL CHARACTERISTICS

PARAMETER	SYMBOL	VALUE	UNIT	
Junction-to-ambient thermal resistance	$\theta_{ja}$	SOT-89-3/-5-2	200 <sup>(6)</sup> 52 <sup>(7)</sup>	°C/W
		TO-252-3-L1	105 <sup>(6)</sup> 40 <sup>(7)</sup>	
Junction-to-Top of package characterization parameter	$\psi_{jt}$	SOT-89-3/-5-2	43 <sup>(6)</sup> 19 <sup>(7)</sup>	°C/W
		TO-252-3-L1	17 <sup>(6)</sup> 12 <sup>(7)</sup>	

(6): Mounted on glass epoxy board. (76.2×114.3×1.6mm: based on EIA/JEDEC standard, 2Layers)

(7): Mounted on glass epoxy board. (76.2×114.3×1.6mm: based on EIA/JEDEC standard, 4Layers), internal Cu area: 74.2x74.2mm

(For 4Layers :Applying 74.2 x 74.2mm inner Cu area and thermal via holes to board based on JEDEC standard JESD51-5)

## ■ POWER DISSIPATION vs. AMBIENT TEMPERATURE

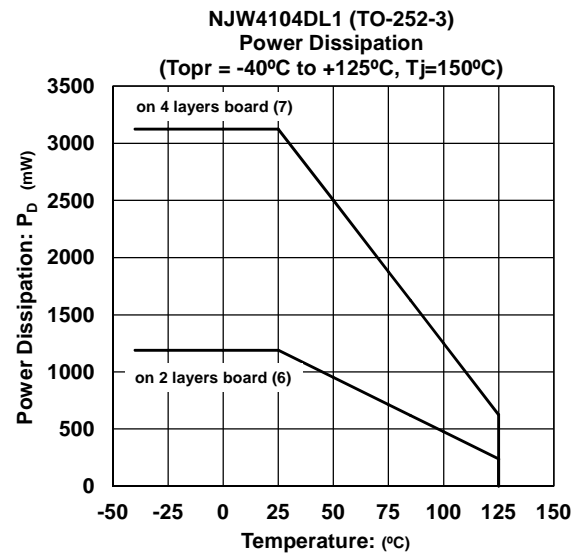
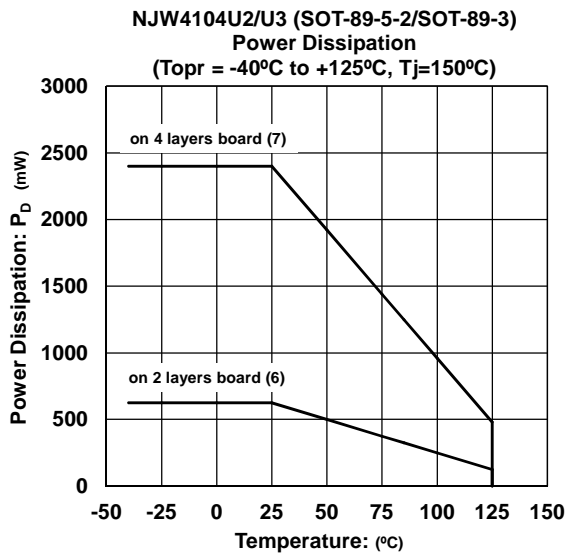

**\*Input Capacitor  $C_{IN}$** 

The input capacitor  $C_{IN}$  is required in order to prevent oscillation and reduce power supply ripple of applications when high power supply impedance or a long power supply line.

Therefore, the recommended capacitance (refer to conditions of ELECTRIC CHARACTERISTIC) or larger input capacitor, connected between  $V_{IN}$  and GND as short path as possible, is recommended in order to avoid the problem.

**\*Output Capacitor  $C_O$** 

The output capacitor  $C_O$  is required for a phase compensation of the internal error amplifier, and the capacitance and the equivalent series resistance (ESR) influence stable operation of the regulator.

If use a smaller output capacitor than the recommended capacitance (refer to conditions of ELECTRIC CHARACTERISTIC), it may cause excess output noise or oscillation of the regulator due to lack of the phase compensation. Therefore, the recommended capacitance or larger output capacitor, connected between  $V_{OUT}$  and GND as short path as possible, is recommended for stable operation. The recommended capacitance may be different by output voltage, therefore confirm the recommended capacitance of the required output voltage.

Furthermore, a larger output capacitor reduces output noise and ripple output, and also improves Output Transient Response when a load changes rapidly.

Selecting the output capacitor, should consider varied characteristics of a capacitor: frequency characteristics, temperature characteristics, DC bias characteristics and so on. Therefore, the capacitor that has a sufficient margin of the rated voltage against the output voltage and superior temperature characteristics, is recommended for  $C_O$ .

**\*Transient Response of Output Voltage**

In general, the regulator tends to cause overshoot or undershoot of output voltage at the following conditions.

Particularly in products featuring low current consumption, the output voltage fluctuation may become large due to product characteristics.

- When input voltage or output current fluctuate sharply
- When output capacitance is small
- When output load is light
- When start up from the condition of narrow voltage difference between an Input and an output.

One way to improve transient response is to use a large capacity input and output capacitors to suppress to the fluctuation.

Amount of transient fluctuation will change according to multiple conditions, so please refer to the above to confirm with actual equipment.

## TYPICAL CHARACTERISTICS

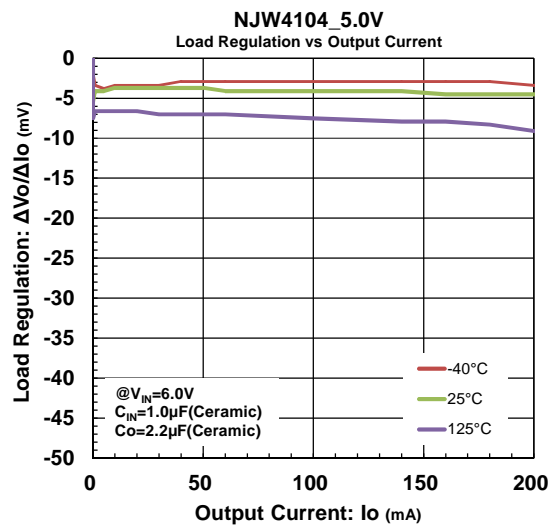
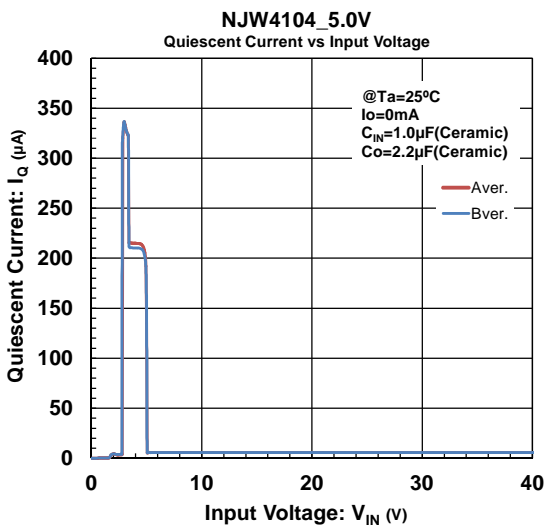
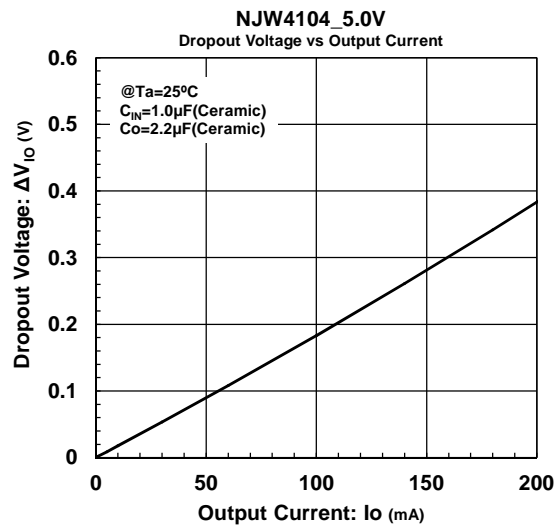
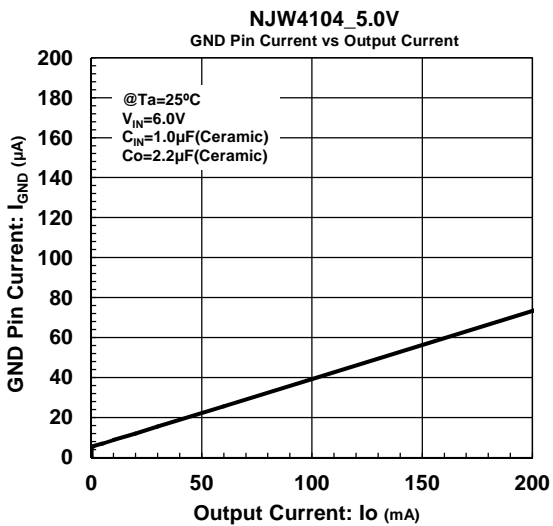
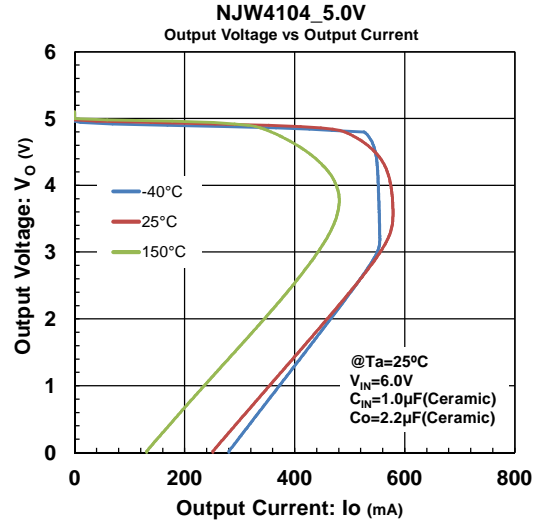
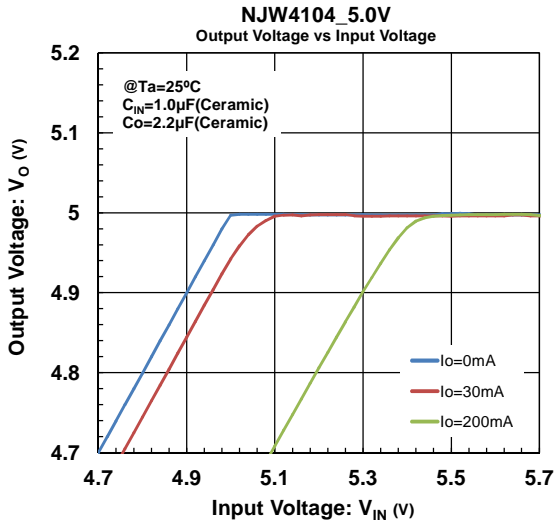

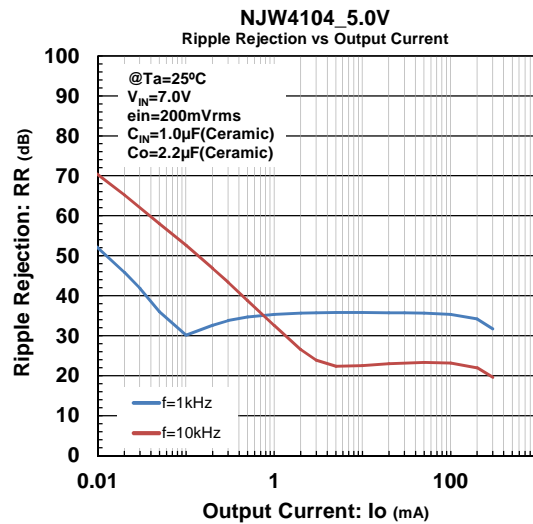
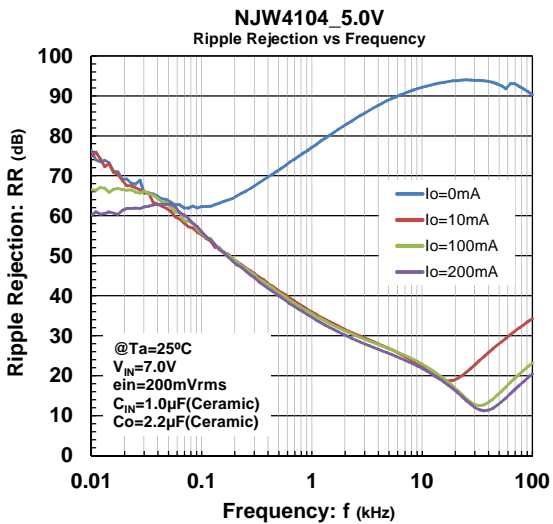
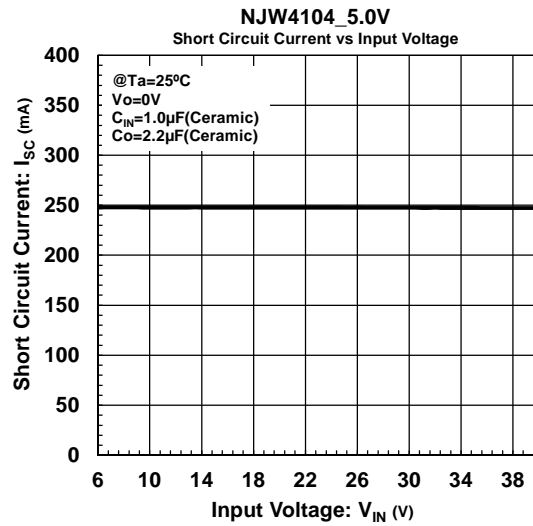
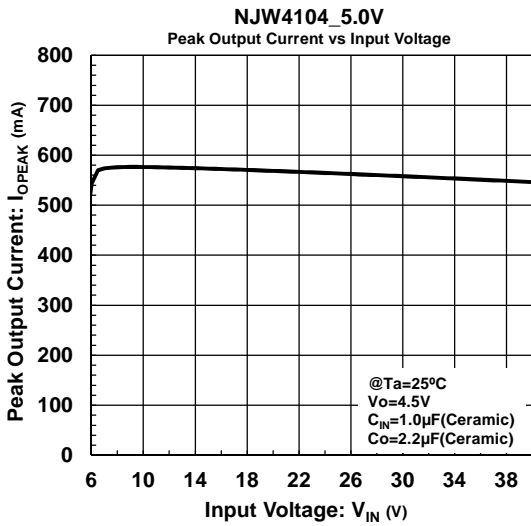
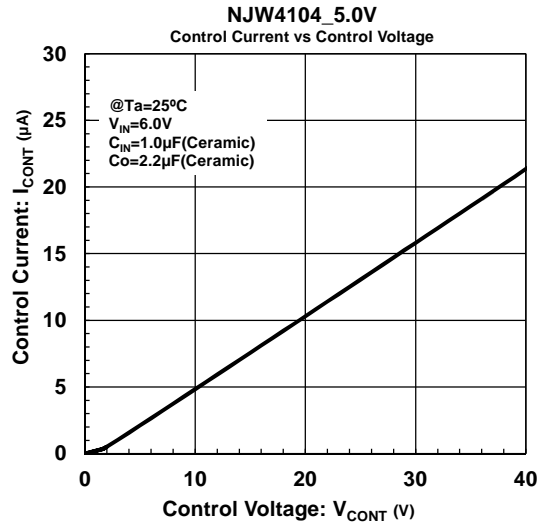
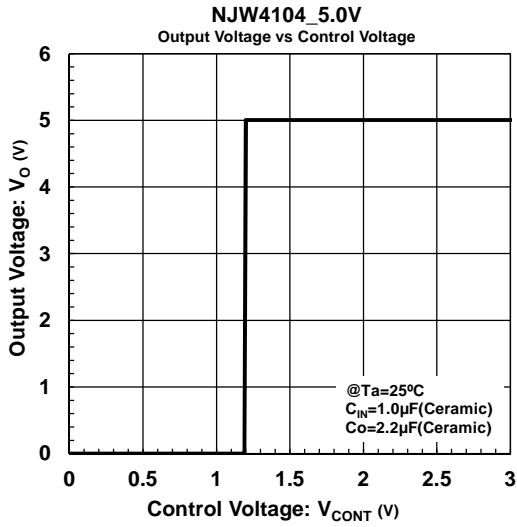



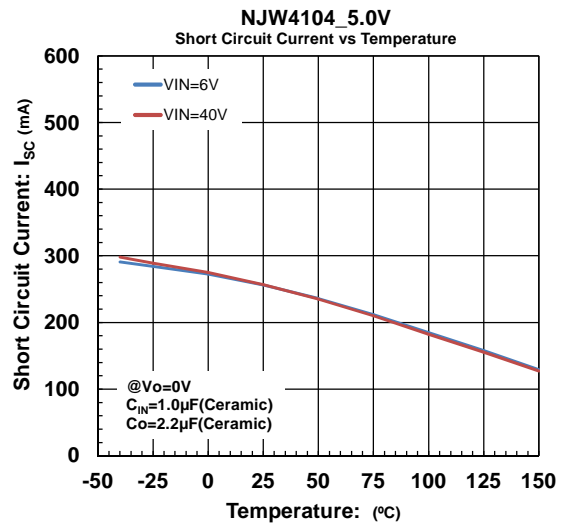
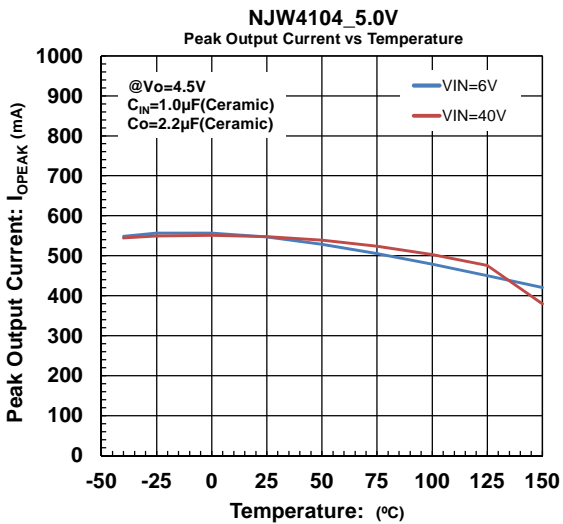
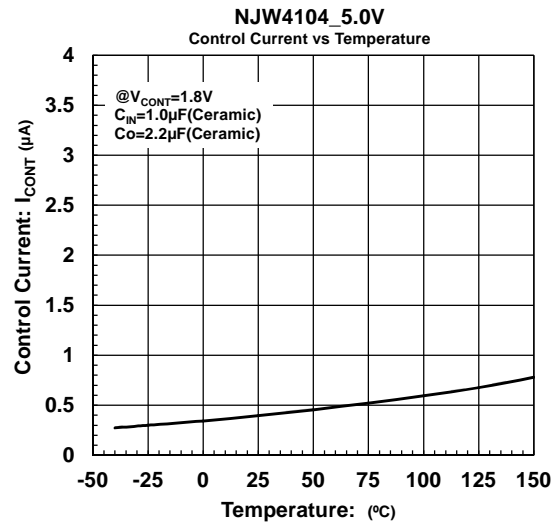
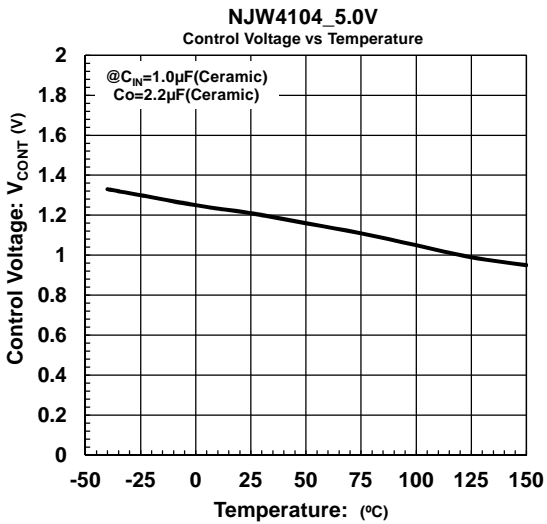
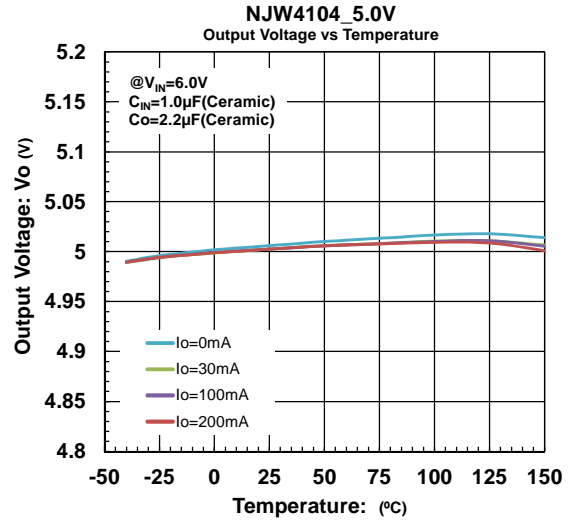
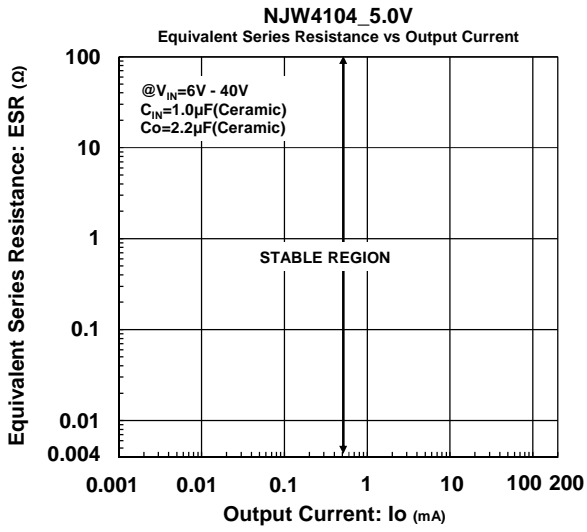

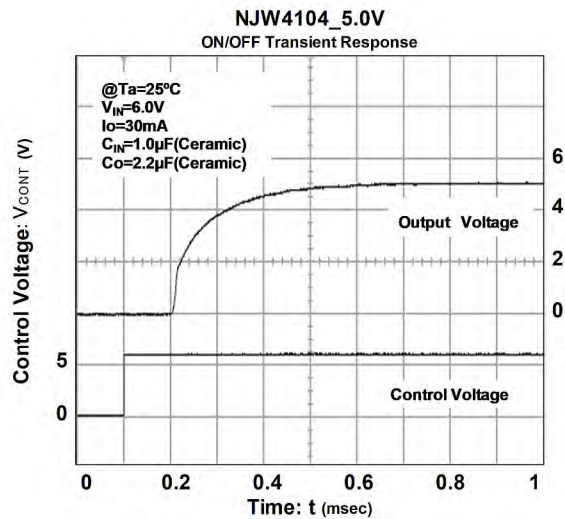
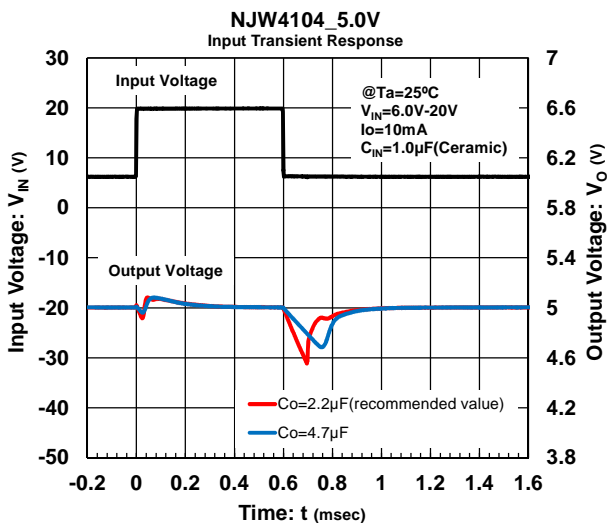
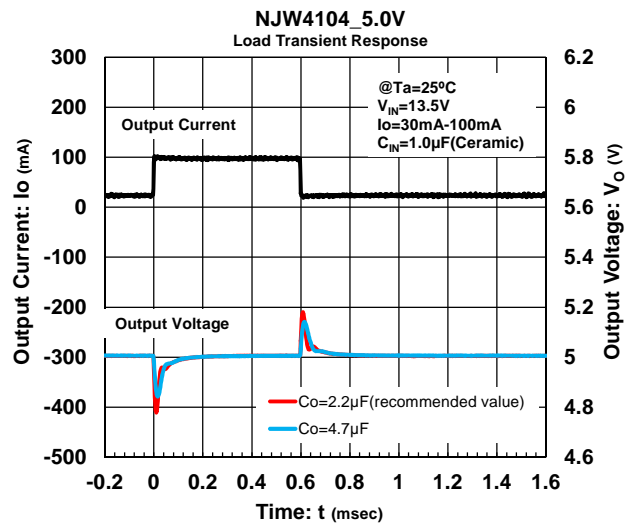
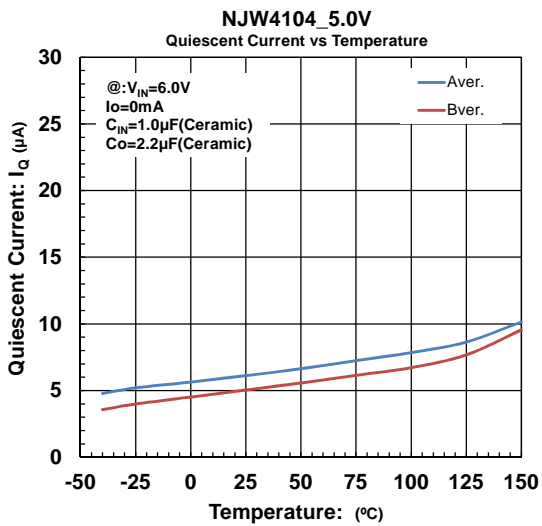
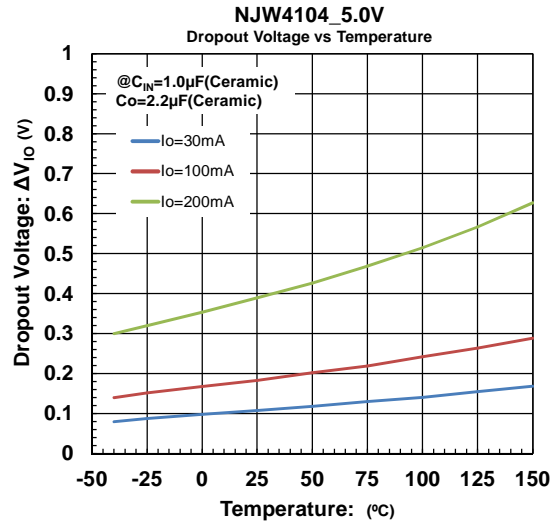
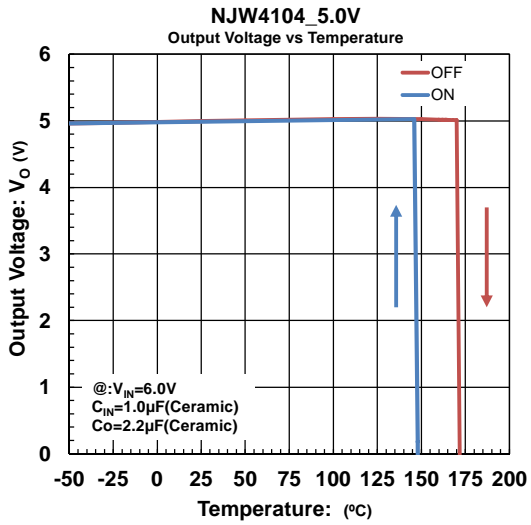

## ■ TYPICAL APPLICATION

### ● A version

1. In the case where ON/OFF Control is not required

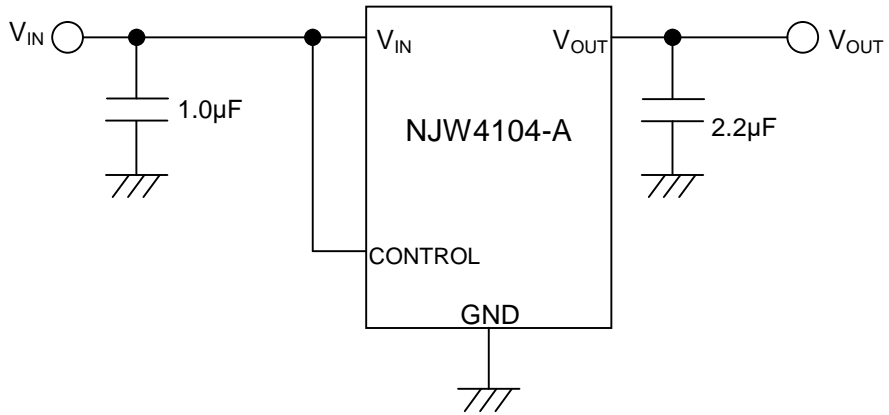

Connect CONTROL Pin to V<sub>IN</sub> Pin

2. In use of ON/OFF CONTROL

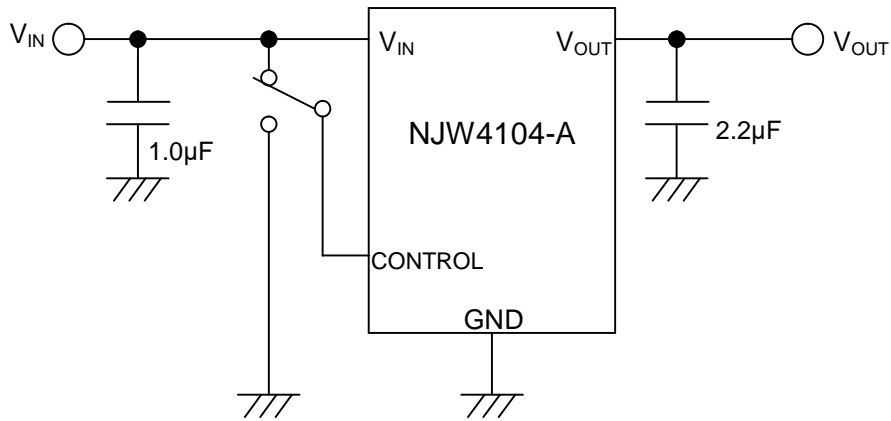

State of CONTROL Pin:

“H” → output is enabled. “L” or “open” → output is disabled

### ● B version

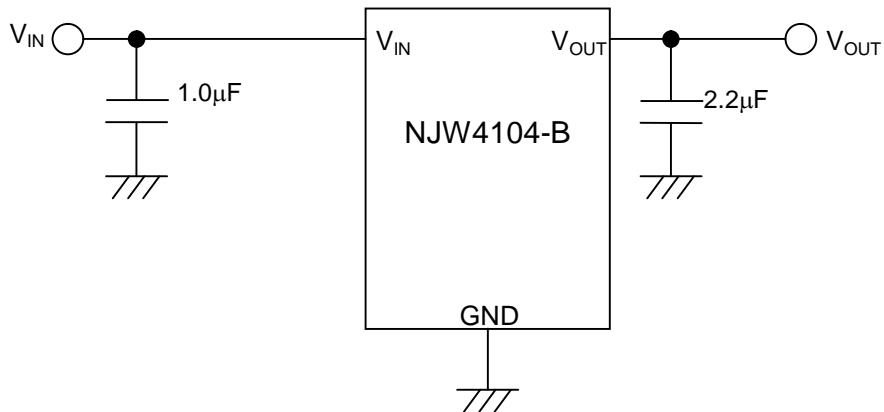

## ■APPLICATION NOTE / GLOSSARY

### \*Under Voltage Lockout UVLO

The NJW4104 includes UVLO circuit to prevent malfunction in case of low input voltage.

When the input voltage increases and exceeds the “UVLO Release voltage” (2.8V typ.),UVLO is released and the output voltage rises up.

The UVLO circuit has hysteresis(200mV typ.). Therefore, if the input voltage decreases below the threshold voltage:“UVLO Release voltage” – “UVLO Hysteresis Voltage”, the output voltage shuts down.

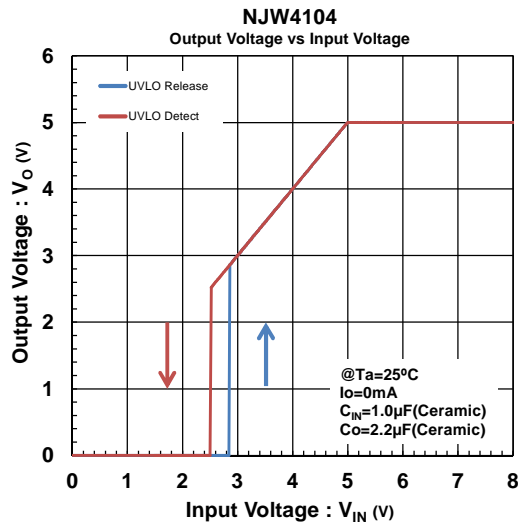

### ■PACKAGE DIMENSIONS

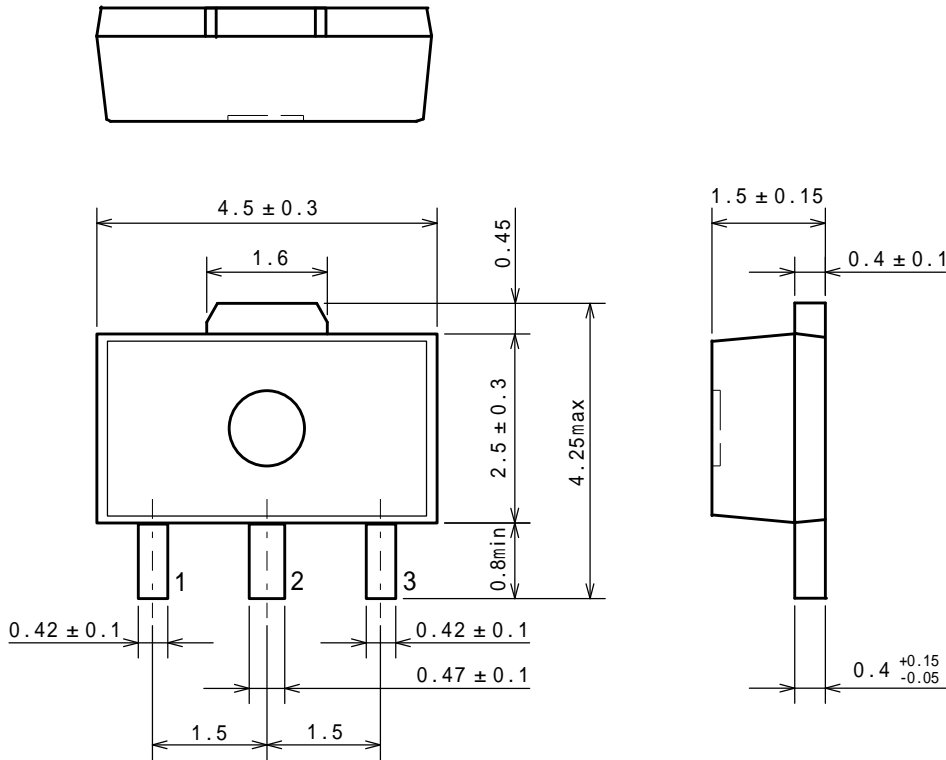

### ■EXAMPLE OF SOLDER PADS DIMENSIONS

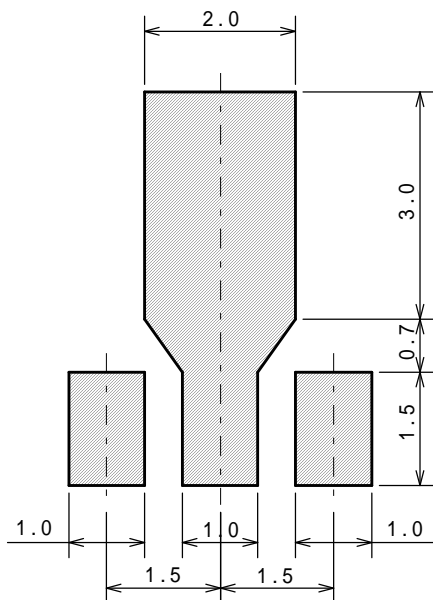



### PACKAGE DIMENSIONS

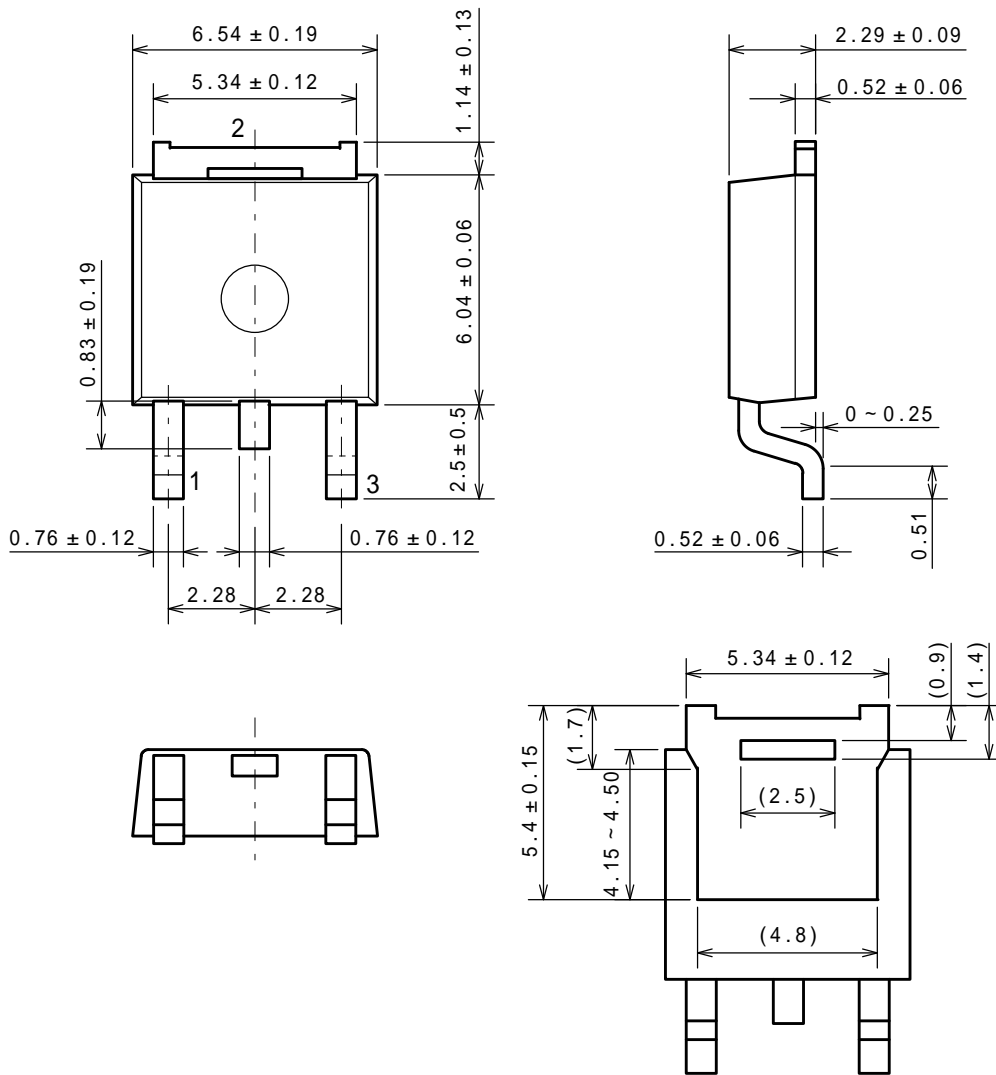

### EXAMPLE OF SOLDER PADS DIMENSIONS

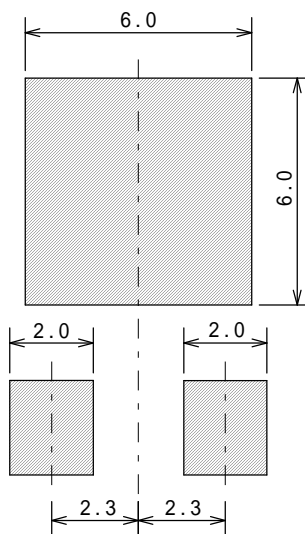

### PACKING SPEC

#### TAPING DIMENSIONS

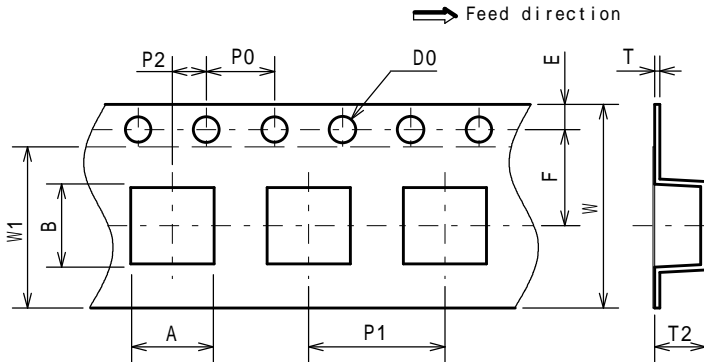

SYMBOL	DIMENSION	REMARKS
A	4.9 ± 0.1	BOTTOM DIMENSION
B	4.5 ± 0.1	BOTTOM DIMENSION
D0	1.5 <sup>+0.1</sup> <sub>0</sub>	
E	1.5 ± 0.1	
F	5.65 ± 0.1	
P0	4.0 ± 0.1	
P1	8.0 ± 0.1	
P2	2.0 ± 0.05	
T	0.3 ± 0.05	
T2	2.0	
W	12.0 ± 0.3	
W1	9.5	THICKNESS 0.1MAX

#### REEL DIMENSIONS

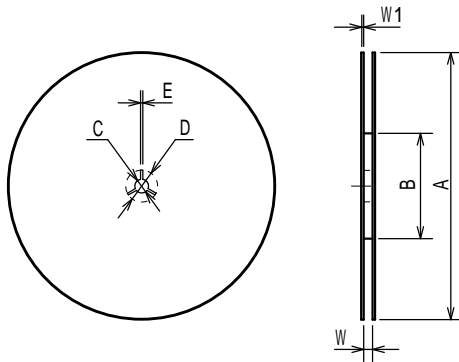

SYMBOL	DIMENSION
A	180 ± 1
B	60 ± 1
C	13 ± 0.2
D	21 ± 0.8
E	2 ± 0.5
W	13 ± 0.5
W1	1.2 ± 0.2

#### TAPING STATE

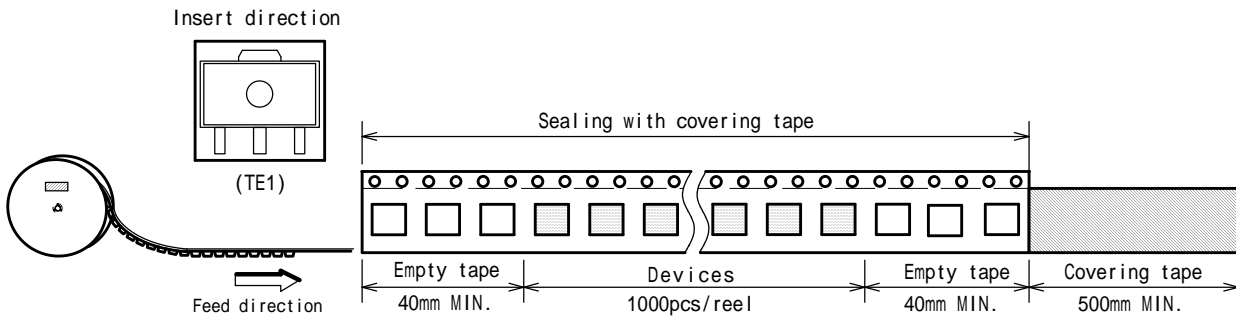

#### PACKING STATE

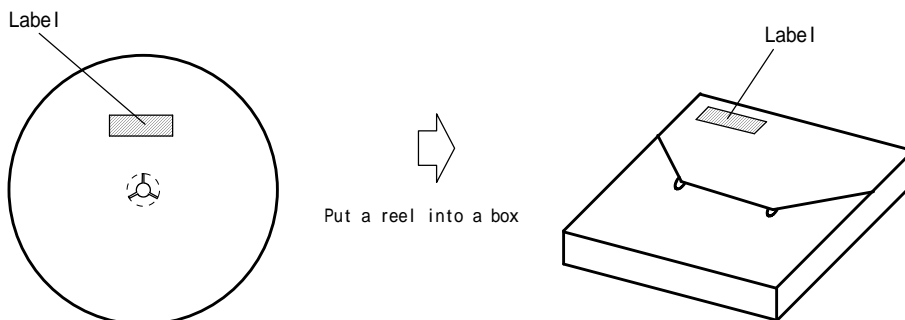



### PACKING SPEC

#### TAPING DIMENSIONS

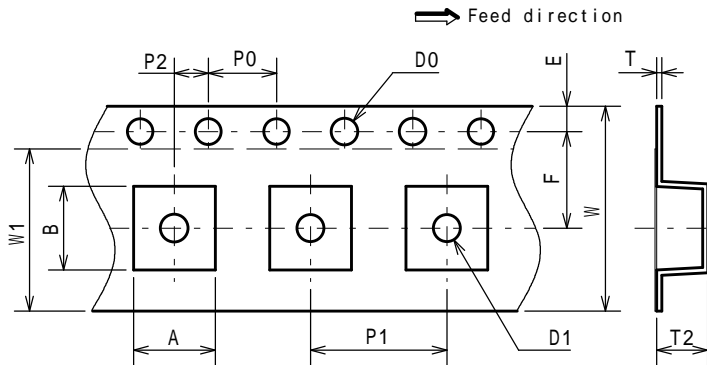

SYMBOL	DIMENSION	REMARKS
A	4.8 ± 0.1	BOTTOM DIMENSION
B	4.9 ± 0.1	BOTTOM DIMENSION
D0	1.5 <sup>+0.1</sup> <sub>0</sub>	
D1	1.6	
E	1.5 ± 0.1	
F	5.65 ± 0.1	
P0	4.0 ± 0.1	
P1	8.0 ± 0.1	
P2	2.0 ± 0.1	
T	0.30 ± 0.05	
T2	2.0 ± 0.1	
W	12.0 ± 0.3	
W1	9.5	THICKNESS 0.1MAX

#### REEL DIMENSIONS

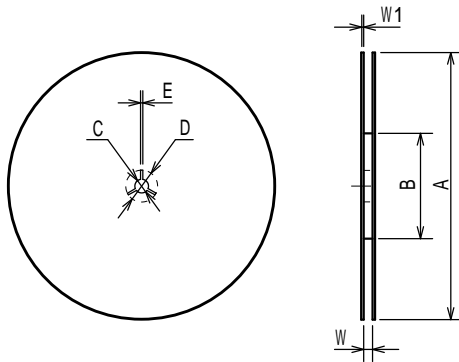

SYMBOL	DIMENSION
A	180 ± 1
B	60 ± 1
C	13 ± 0.2
D	21 ± 0.8
E	2 ± 0.5
W	13 ± 0.5
W1	1.2 ± 0.2

#### TAPING STATE

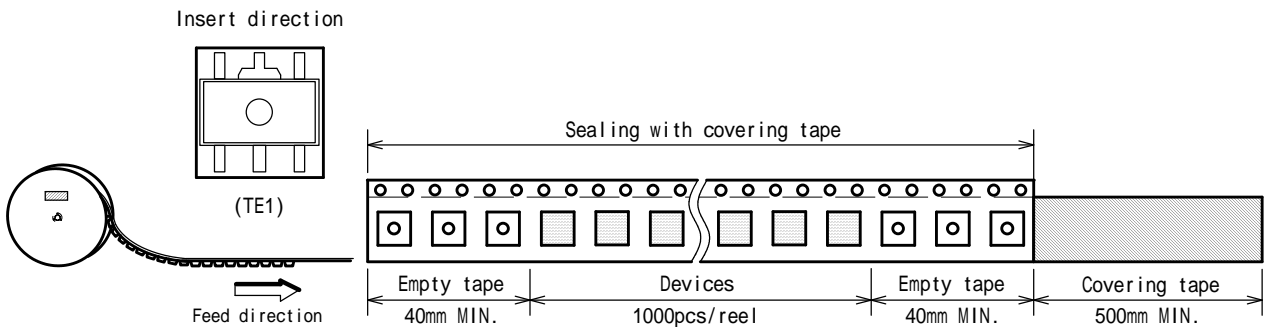

#### PACKING STATE

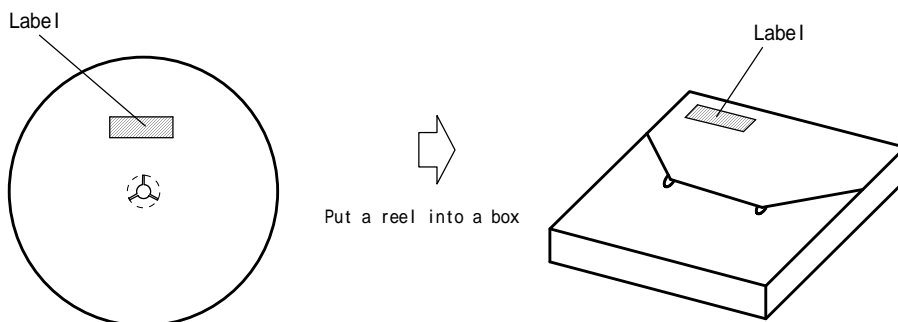

### PACKING SPEC TAPING DIMENSIONS

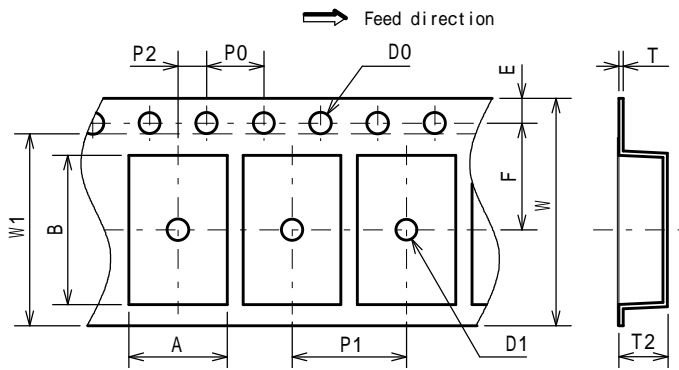

SYMBOL	DIMENSION	REMARKS
A	6.9 ± 0.1	BOTTOM DIMENSION
B	10.5 ± 0.1	BOTTOM DIMENSION
D0	1.5 <sup>+0.1</sup> / <sub>0</sub>	
D1	1.5 <sup>+0.1</sup> / <sub>0</sub>	
E	1.75 ± 0.1	
F	7.5 ± 0.05	
P0	4.0 ± 0.1	
P1	8.0 ± 0.1	
P2	2.0 ± 0.05	
T	0.3 ± 0.05	
T2	3.4 max	
W	16.0 ± 0.3	
W1	13.5	THICKNESS 0.1max

### REEL DIMENSIONS

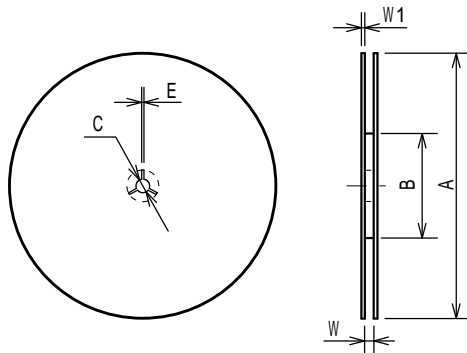

SYMBOL	DIMENSION
A	330 ± 2
B	80 ± 1
C	13 ± 0.5
E	2
W	17.5 ± 0.5
W1	2 ± 0.5

### TAPING STATE

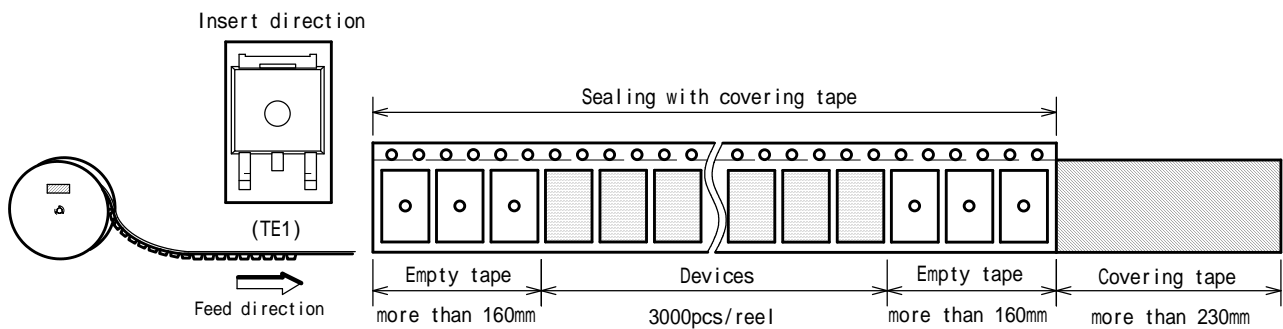

### PACKING STATE

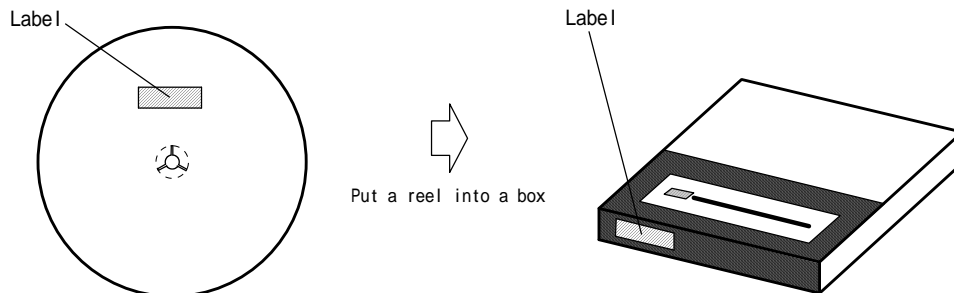

## RECOMMENDED MOUNTING METHOD

### INFRARED REFLOW SOLDERING METHOD

Recommended reflow soldering procedure

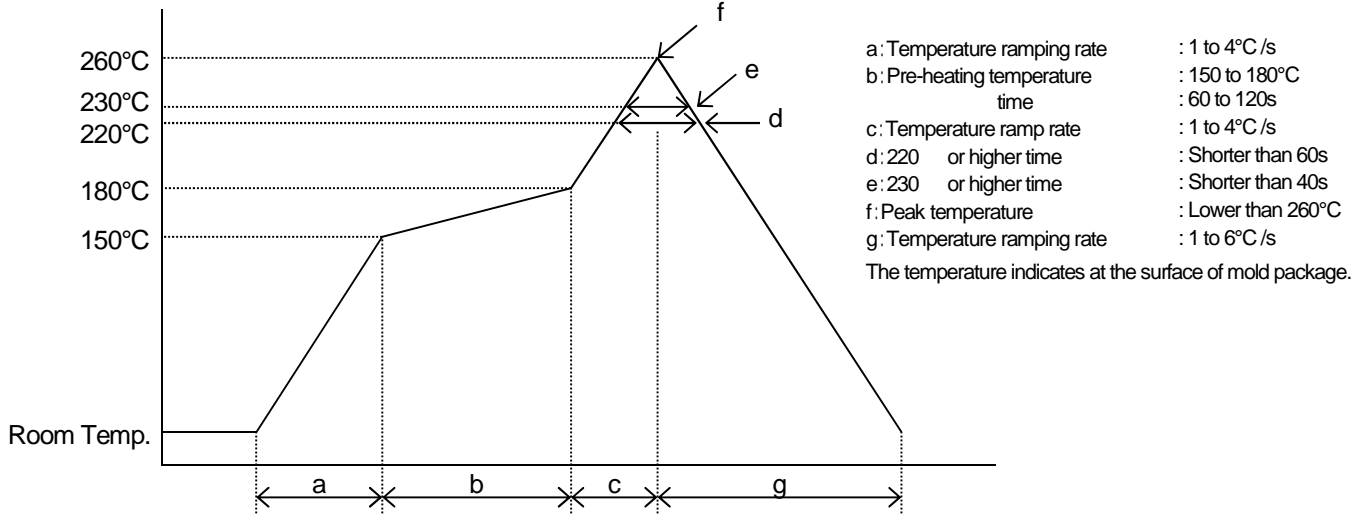

### INFRARED FLOW SOLDERING METHOD

\*flow soldering procedure

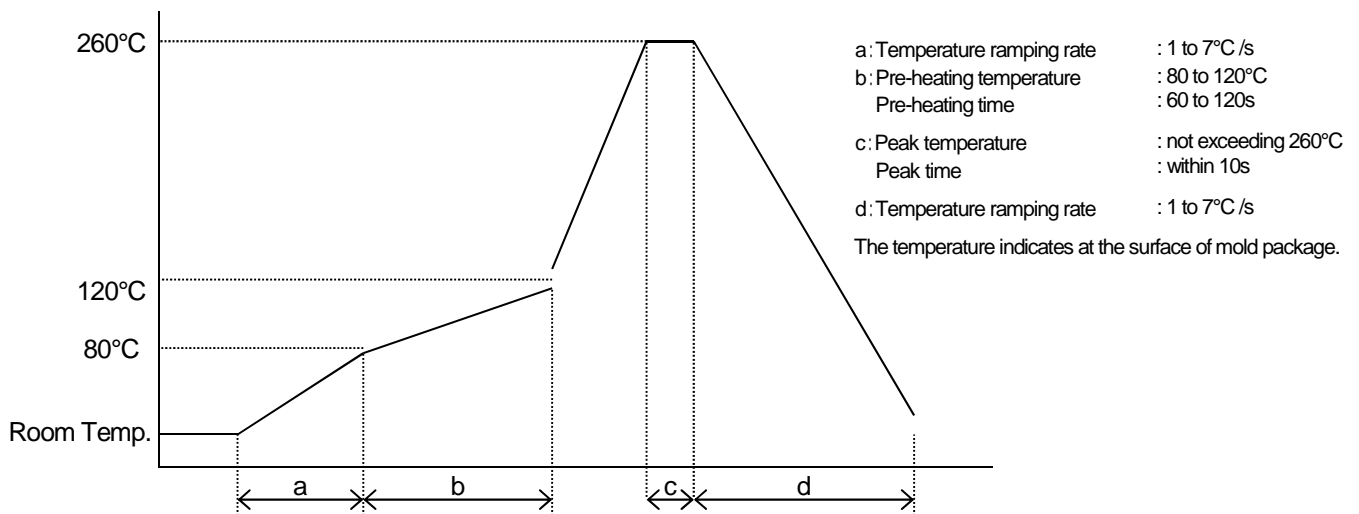

**■REVISION HISTORY**

Date	Revision	Changes
04.Apr.2017.	Ver.1.0	New Release
27.Aug.2018	Ver.1.1	Correction of erroneous description

**[ CAUTION ]**

1. New JRC strives to produce reliable and high quality semiconductors. New JRC's semiconductors are intended for specific applications and require proper maintenance and handling. To enhance the performance and service of New JRC's semiconductors, the devices, machinery or equipment into which they are integrated should undergo preventative maintenance and inspection at regularly scheduled intervals. Failure to properly maintain equipment and machinery incorporating these products can result in catastrophic system failures
2. The specifications on this datasheet are only given for information without any guarantee as regards either mistakes or omissions. The application circuits in this datasheet are described only to show representative usages of the product and not intended for the guarantee or permission of any right including the industrial rights. All other trademarks mentioned herein are property of their respective companies.
3. To ensure the highest levels of reliability, New JRC products must always be properly handled. The introduction of external contaminants (e.g. dust, oil or cosmetics) can result in failures of semiconductor products.
4. New JRC offers a variety of semiconductor products intended for particular applications. It is important that you select the proper component for your intended application. You may contact New JRC's Sale's Office if you are uncertain about the products listed in this catalog.
5. Special care is required in designing devices, machinery or equipment which demand high levels of reliability. This is particularly important when designing critical components or systems whose failure can foreseeably result in situations that could adversely affect health or safety. In designing such critical devices, equipment or machinery, careful consideration should be given to amongst other things, their safety design, fail-safe design, back-up and redundancy systems, and diffusion design.
6. The products listed in the catalog may not be appropriate for use in certain equipment where reliability is critical or where the products may be subjected to extreme conditions. You should consult our sales office before using the products in any of the following types of equipment.

Aerospace Equipment  
Equipment Used in the Deep sea  
Power Generator Control Equipment (Nuclear, Steam, Hydraulic)  
Life Maintenance Medical Equipment  
Fire Alarm/Intruder Detector  
Vehicle Control Equipment (airplane, railroad, ship, etc.)  
Various Safety devices

7. New JRC's products have been designed and tested to function within controlled environmental conditions. Do not use products under conditions that deviate from methods or applications specified in this catalog. Failure to employ New JRC products in the proper applications can lead to deterioration, destruction or failure of the products. New JRC shall not be responsible for any bodily injury, fires or accident, property damage or any consequential damages resulting from misuse or misapplication of its products. Products are sold without warranty of any kind, either express or implied, including but not limited to any implied warranty of merchantability or fitness for a particular purpose.
8. Warning for handling Gallium and Arsenic(GaAs) Products (Applying to GaAs MMIC, Photo Reflector). This Products uses Gallium(Ga) and Arsenic(As) which are specified as poisonous chemicals by law. For the prevention of a hazard, do not burn, destroy, or process chemically to make them as gas or power. When the product is disposed, please follow the related regulation and do not mix this with general industrial waste or household waste.
9. The product specifications and descriptions listed in this catalog are subject to change at any time, without notice.



## X-ON Electronics

Largest Supplier of Electrical and Electronic Components

*Click to view similar products for [LDO Voltage Regulators](#) category:*

*Click to view products by [Nisshinbo](#) manufacturer:*

Other Similar products are found below :

[AP7363-SP-13](#) [NCV8664CST33T3G](#) [L79M05TL-E](#) [AP7362-HA-7](#) [PT7M8202B12TA5EX](#) [TCR3DF185,LM\(CT](#) [TLF4949EJ](#)  
[NCP4687DH15T1G](#) [NCV8703MX30TCG](#) [LP2951CN](#) [NCV4269CPD50R2G](#) [AP7315-25W5-7](#) [NCV47411PAAJR2G](#) [AP2111H-1.2TRG1](#)  
[ZLDO1117QK50TC](#) [AZ1117ID-ADJTRG1](#) [NCV4263-2CPD50R2G](#) [NCP706ABMX300TAG](#) [NCP114BMX075TCG](#) [MC33269T-3.5G](#)  
[TLE4471GXT](#) [AP7315-33SA-7](#) [NCV4266-2CST33T3G](#) [NCP715SQ15T2G](#) [NCV8623MN-50R2G](#) [NCV563SQ18T1G](#) [NCV8664CDT33RKG](#)  
[NCV4299CD250R2G](#) [NCP715MX30TBG](#) [NCV8702MX25TCG](#) [TLE7270-2E](#) [NCV562SQ25T1G](#) [AP2213D-3.3TRG1](#) [AP2202K-2.6TRE1](#)  
[NCV8170BMX300TCG](#) [NCV8152MX300180TCG](#) [NCP700CMT45TBG](#) [AP7315-33W5-7](#) [NCP154MX180300TAG](#) [AP2113AMTR-G1](#)  
[NJW4104U2-33A-TE1](#) [MP2013AGG-5-P](#) [NCV8775CDT50RKG](#) [NJM2878F3-45-TE1](#) [S-19214B00A-V5T2U7](#) [S-19214B50A-V5T2U7](#) [S-](#)  
[19213B50A-V5T2U7](#) [S-19214BC0A-E8T1U7\\*1](#) [S-19213B00A-V5T2U7](#) [S-19213B33A-V5T2U7](#)