

## Switching Regulator IC for Boost Converter

w/ 40V/1.4A or 40V/1A MOSFET

### ■ GENERAL DESCRIPTION

The **NJW4131** is a boost converter with **40V/1.4A** or **40V/1A** MOSFET. It corresponds to high oscillating frequency, and Low ESR Output Capacitor (MLCC) within wide input range from 4.0V to 35V.

Therefore, the **NJW4131** can realize downsizing of an application with a few external parts.

Also, it has a soft start function, an over current protection and a thermal shutdown circuit.

It is suitable for power supply to a Car Accessory, Office Automation equipment, Industrial Instrument, LED and so on.

### ■ PACKAGE OUTLINE

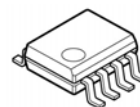

**NJW4131GM1-A  
(HSOP8)**



**NJW4131R-B  
(MSOP8 (VSP8))**

### ■ FEATURES

- Output Switch Voltage                    40V max.
- Wide Operating Voltage Range        4V to 35V
- Switching Current                        1.4A (min.) @ A version  
    1.0A (min.) @ B version
- PWM Control
- Wide Oscillation Frequency            300kHz to 1MHz
- Soft-Start Function                        4ms typ.
- UVLO (Under Voltage Lockout)
- Over Current Protection / Thermal Shutdown Protection
- Standby Function
- Package Outline                            NJW4131GM1:    HSOP8  
    NJW4131R:        MSOP8(VSP8)\*  
    \*MEET JEDEC MO-187-DA

### ■ PRODUCT CLASSIFICATION

PART NUMBER	VERSION	SWITCHING CURRENT LIMIT (MIN.)	PACKAGE	OPERATING TEMPERATURE RANGE
NJW4131GM1-A	A	1.4A	HSOP8	-40°C to +85°C
NJW4131R-B	B	1.0A	MSOP8(VSP8)	-40°C to +85°C

# NJW4131

## ■ PIN CONFIGURATION

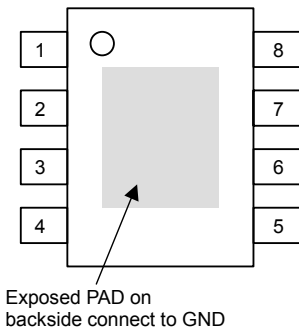

NJW4131GM1-A

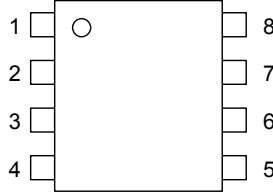

NJW4131R-B

## PIN FUNCTION

1. SW
2. ON/OFF
3. V<sup>+</sup>
4. RT
5. IN-
6. FB
7. AGND
8. PGND

## ■ BLOCK DIAGRAM

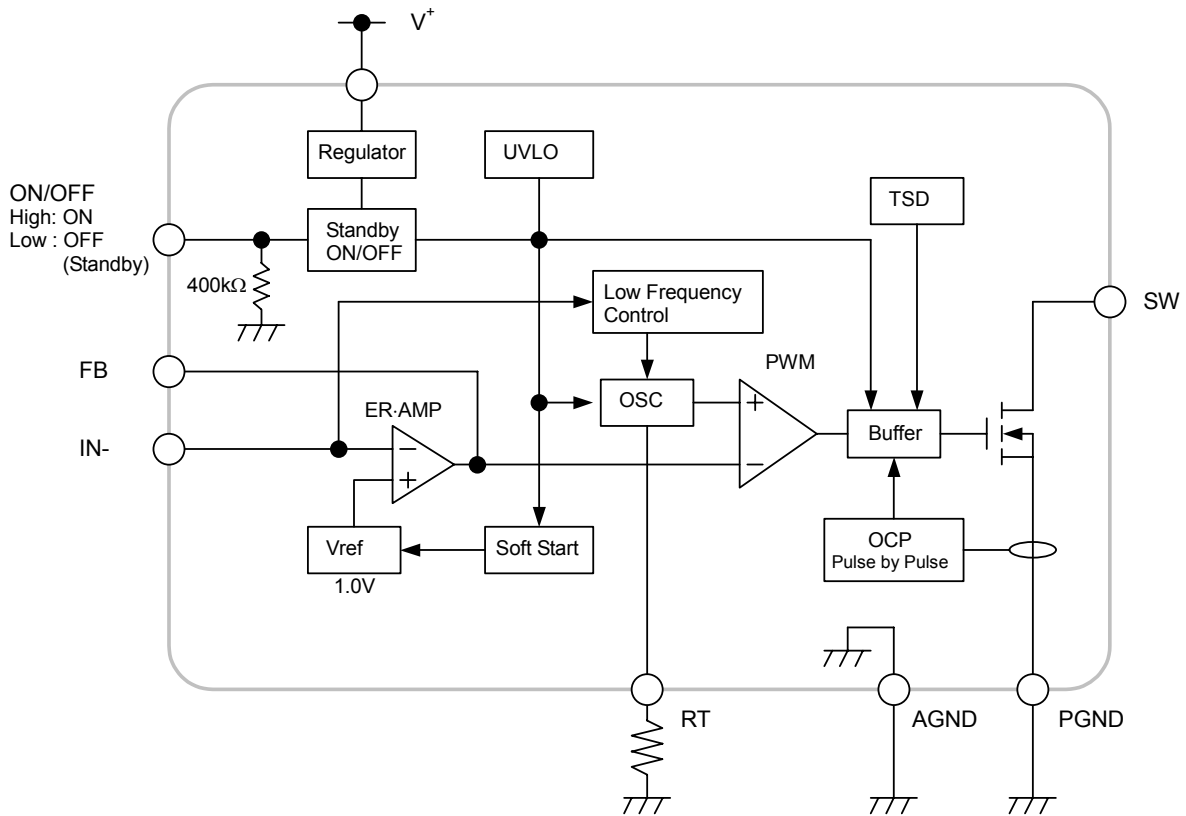

## ■ ABSOLUTE MAXIMUM RATINGS

(Ta=25°C)

PARAMETER	SYMBOL	MAXIMUM RATINGS	UNIT
Supply Voltage	V <sup>+</sup>	+40	V
SW pin Voltage	V <sub>SW</sub>	+40	V
IN- pin Voltage	V <sub>IN-</sub>	-0.3 to +6	V
ON/OFF pin Voltage	V <sub>ON/OFF</sub>	+40	V
Power Dissipation	P <sub>D</sub>	HSOP8      790 (*1) 2,500 (*2) MSOP8(VSP8) 595 (*1) 805 (*2)	mW
Junction Temperature Range	T <sub>j</sub>	-40 to +150	°C
Operating Temperature Range	T <sub>opr</sub>	-40 to +85	°C
Storage Temperature Range	T <sub>stg</sub>	-40 to +150	°C

(\*1): Mounted on glass epoxy board. (76.2×114.3×1.6mm:EIA/JDEC standard size, 2Layers)

(\*2): Mounted on glass epoxy board. (76.2×114.3×1.6mm:EIA/JDEC standard size, 4Layers),  
internal foil area: 74.2×74.2mm

## ■ RECOMMENDED OPERATING CONDITIONS

PARAMETER	SYMBOL	MIN.	TYP.	MAX.	UNIT
Supply Voltage	V <sup>+</sup>	4.0	–	35	V
Timing Resistance	R <sub>T</sub>	18	27	68	kΩ
Oscillating Frequency	f <sub>osc</sub>	300	700	1,000	kHz

# NJW4131

## ■ ELECTRICAL CHARACTERISTICS

(Unless other noted,  $V^+=V_{ON/OFF}=12V$ ,  $R_T=27k\Omega$ ,  $T_a=25^\circ C$ )

PARAMETER	SYMBOL	TEST CONDITION	MIN.	TYP.	MAX.	UNIT
<b>Under Voltage Lockout Block</b>						
ON Threshold Voltage	$V_{T\_ON}$	$V^+=L \rightarrow H$	3.8	3.9	4.0	V
OFF Threshold Voltage	$V_{T\_OFF}$	$V^+=H \rightarrow L$	3.7	3.8	3.9	V
Hysteresis Voltage	$V_{HYS}$		60	100	–	mV
<b>Soft Start Block</b>						
Soft Start Time	$T_{SS}$	$V_B=0.95V$	2	4	8	ms
<b>Oscillator Block</b>						
Oscillation Frequency	$f_{OSC}$		630	700	770	kHz
Oscillation Frequency (Low Frequency Control)	$f_{OSC\_LOW}$	$V_{IN}=0.4V, V_{FB}=0.65V$	–	270	–	kHz
RT pin Voltage	$V_{RT}$		0.240	0.275	0.310	V
Oscillate Supply Voltage Fluctuations	$f_{DV}$	$V^+=4V$ to 35V	–	1	–	%
Oscillate Temperature Fluctuations	$f_{DT}$	$T_a=-40^\circ C$ to $+85^\circ C$	–	3	–	%
<b>Error Amplifier Block</b>						
Reference Voltage	$V_B$		-1.0%	1.00	+1.0%	V
Input Bias Current	$I_B$		-0.1	–	+0.1	$\mu A$
Open Loop Gain	$A_V$		–	80	–	dB
Gain Bandwidth	$G_B$		–	0.6	–	MHz
Output Source Current	$I_{OM+}$	$V_{FB}=1V, V_{IN}=0.9V$	8	16	24	$\mu A$
Output Sink Current	$I_{OM-}$	$V_{FB}=1V, V_{IN}=1.1V$	1	2	4	mA
<b>PWM Compare Block</b>						
Maximum Duty Cycle	$M_{AXD\_UTY}$	$V_{IN}=0.9V$	85	90	95	%
<b>Output Block</b>						
Output ON Resistance	$R_{ON}$	A version, $I_{SW}=1A$	–	0.2	0.4	$\Omega$
		B version, $I_{SW}=1A$	–	0.2	0.4	$\Omega$
Switching Current Limit	$I_{LIM}$	A version	1.4	1.7	2.0	A
		B version	1	1.35	1.7	A
Switching Leak Current	$I_{LEAK}$	$V_{ON/OFF}=0V, V_{SW}=40V$	–	–	1	$\mu A$
<b>ON/OFF Block</b>						
ON Control Voltage	$V_{ON}$	$V_{ON/OFF}=L \rightarrow H$	1.6	–	$V^+$	V
OFF Control Voltage	$V_{OFF}$	$V_{ON/OFF}=H \rightarrow L$	0	–	0.5	V
Pull-down Resistance	$R_{PD}$		–	400	–	k $\Omega$
<b>General Characteristics</b>						
Quiescent Current	$I_{DD}$	$R_L=no\ load, V_{IN}=0.9V, V_{FB}=0.65V$	–	2.3	2.8	mA
Standby Current	$I_{DD\_STB}$	$V_{ON/OFF}=0V$	–	–	1	$\mu A$

## ■ TYPICAL APPLICATIONS

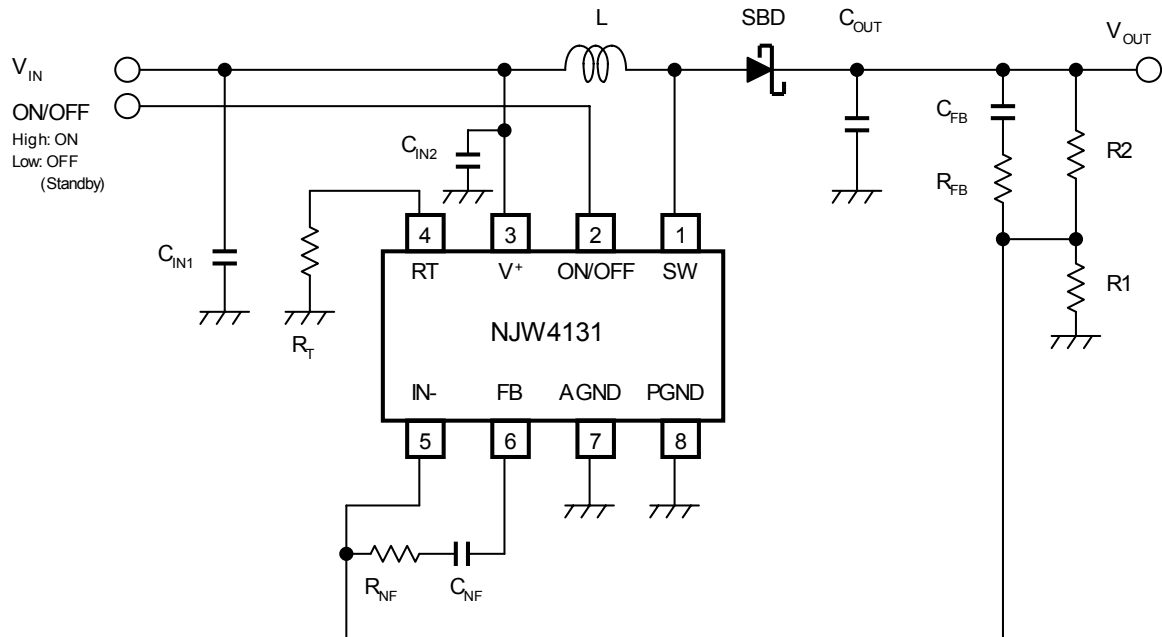

## CHARACTERISTICS

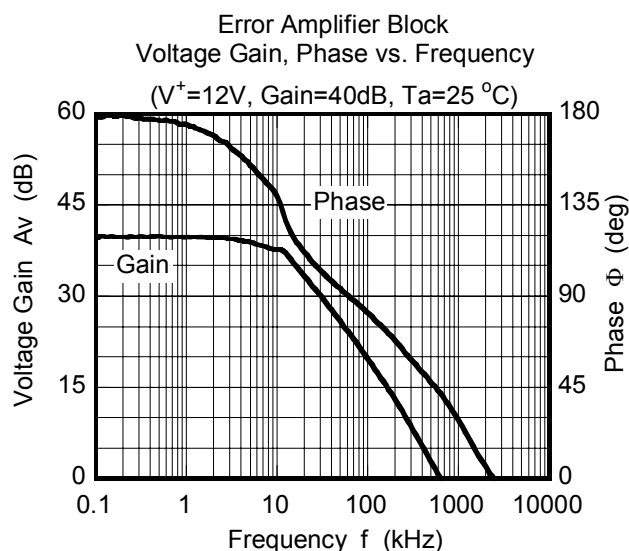
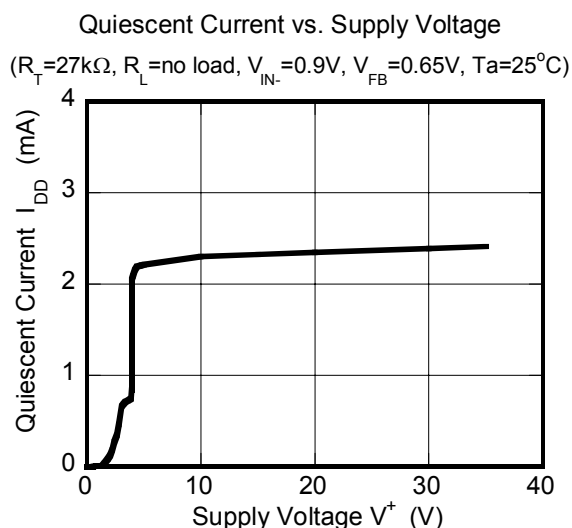
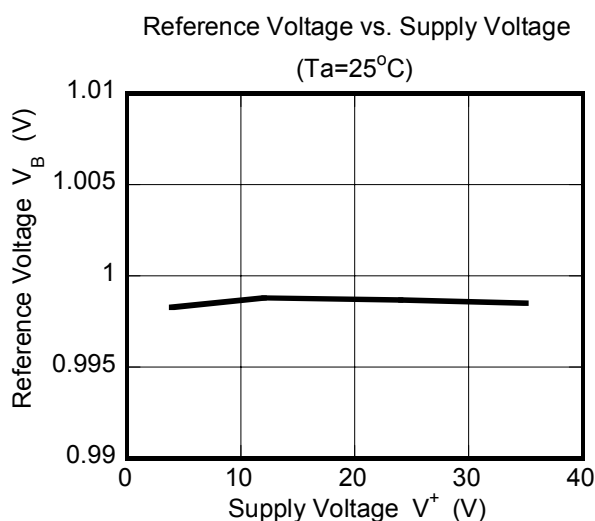
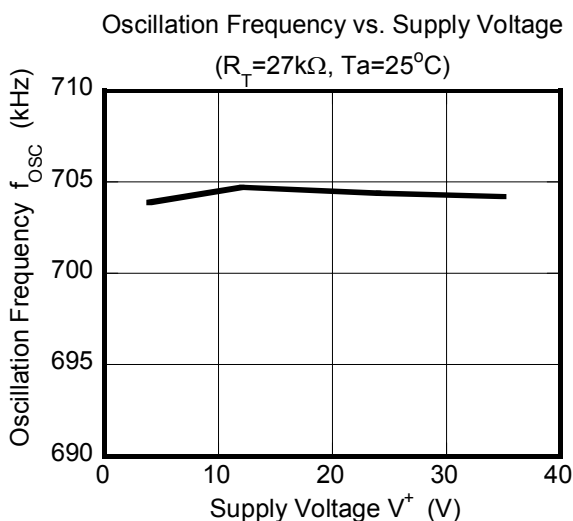
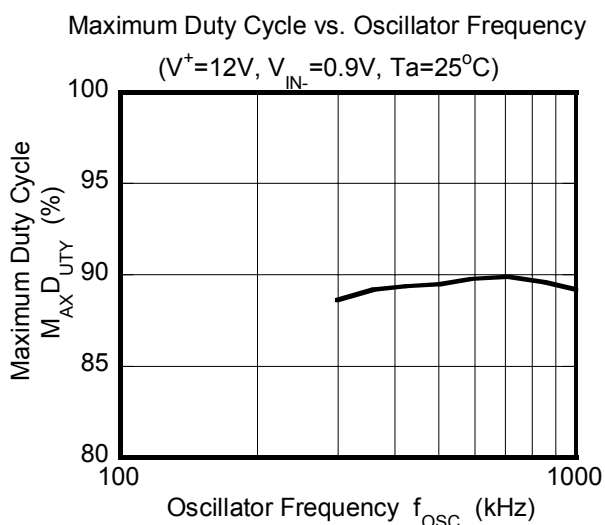
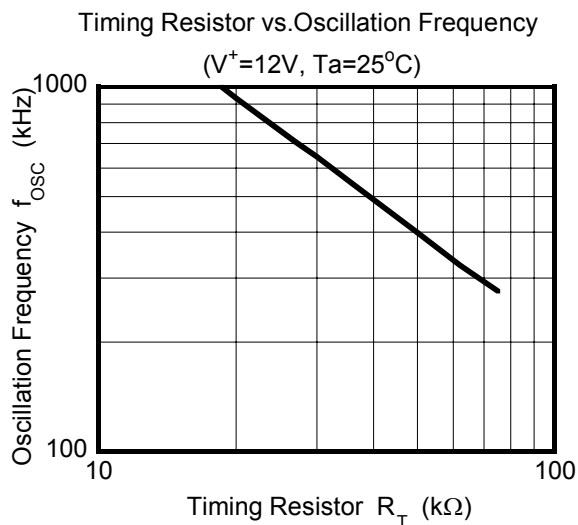

## CHARACTERISTICS

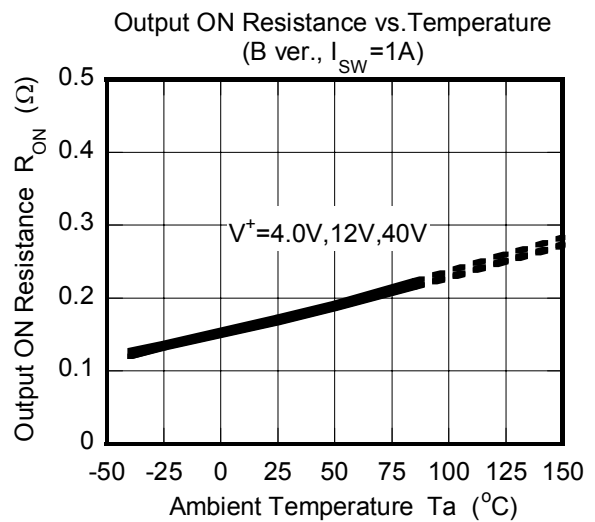
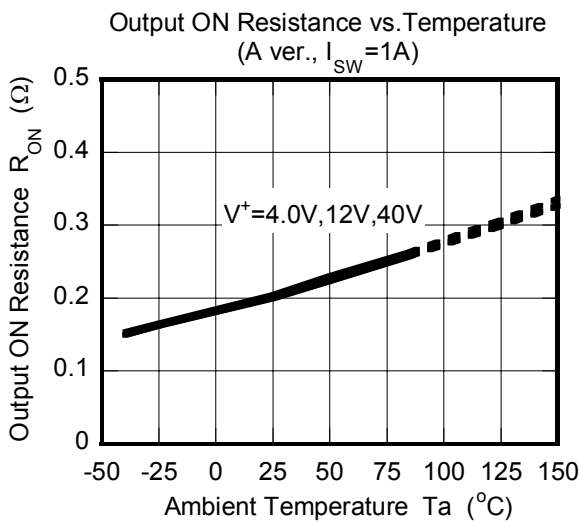
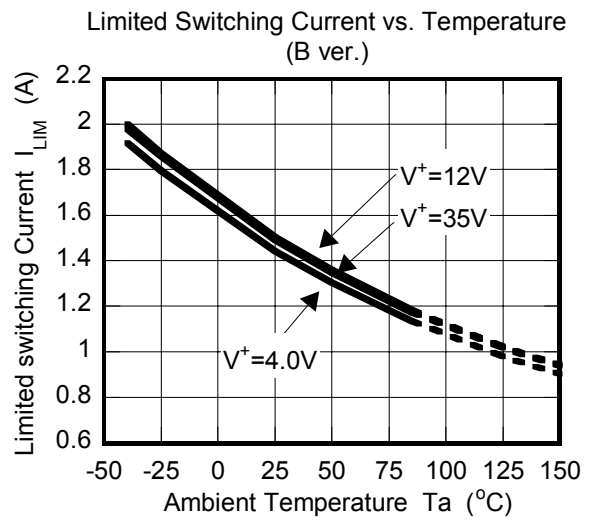
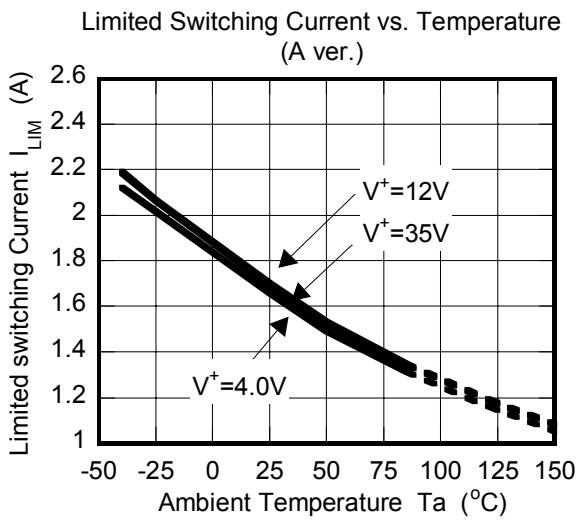
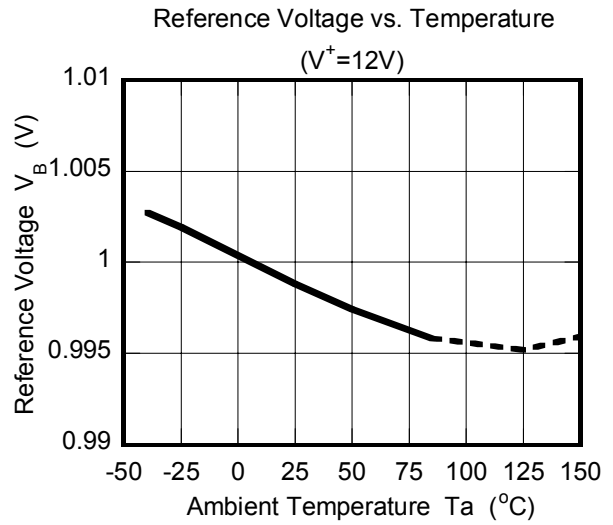
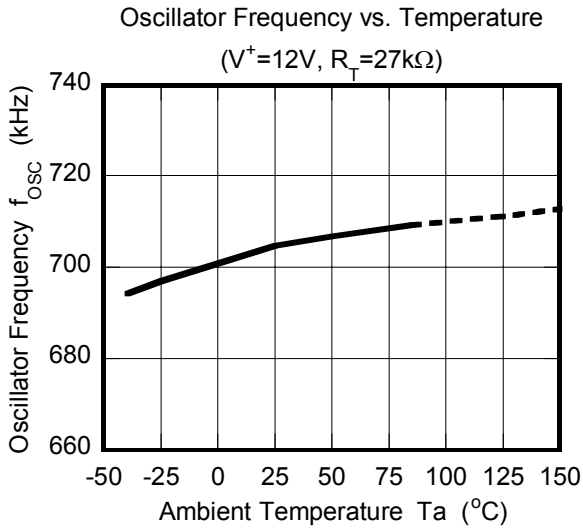

## CHARACTERISTICS

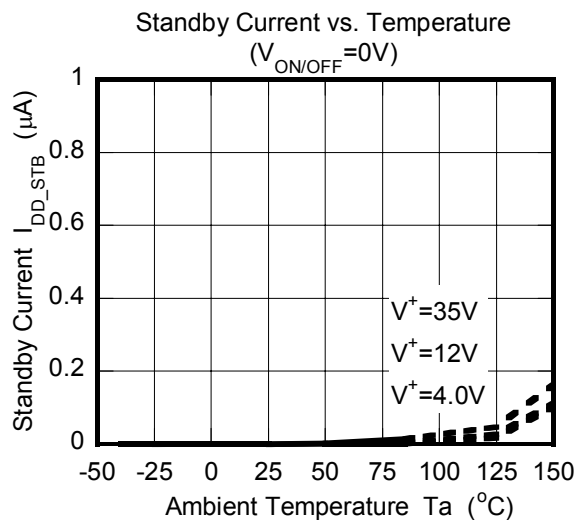
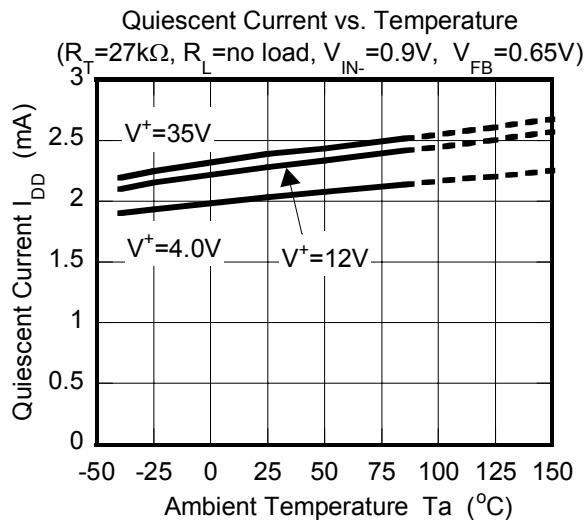
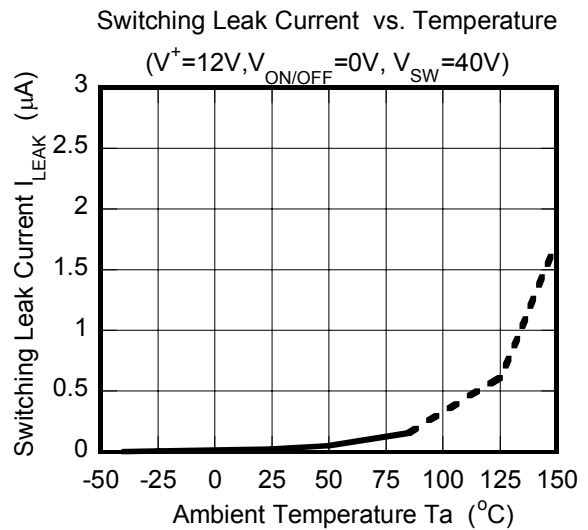
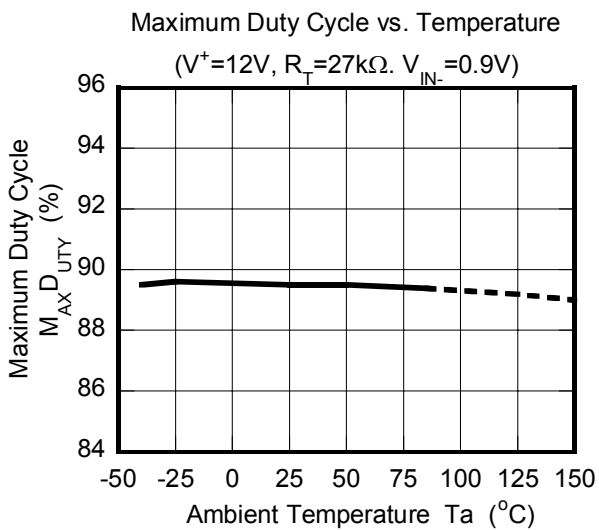
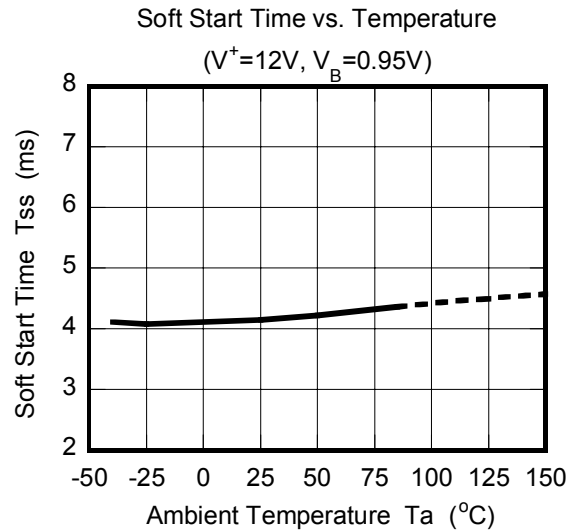
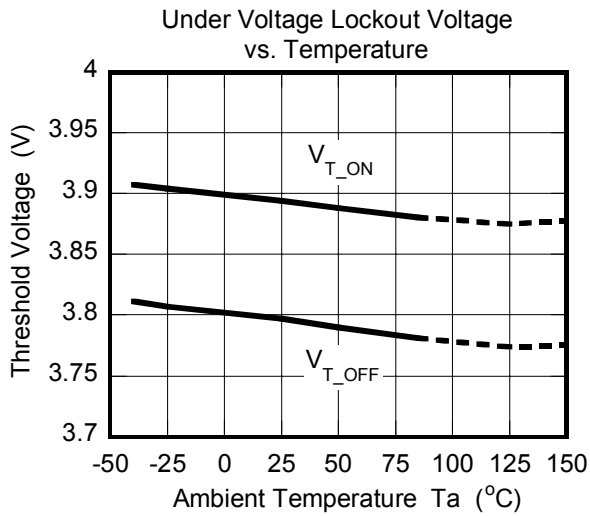



### ■ PIN DISCRIPTION

PIN NUMBER	PIN NAME	FUNCTION
1	SW	Switch Output pin of Power MOSFET
2	ON/OFF	ON/OFF Control pin The ON/OFF pin internally pulls down with 400kΩ. Normal Operation at the time of High Level. Standby Mode at the time of Low Level or OPEN.
3	V <sup>+</sup>	Power Supply pin for IC Control
4	RT	Oscillating Frequency Setting pin by Timing Resistor. Oscillating Frequency should set between 300kHz and 1MHz.
5	IN-	Output Voltage Detecting pin Connects output voltage through the resistor divider tap to this pin in order to voltage of the IN- pin become 1.0V.
6	FB	Feedback Setting pin The feedback resistor and capacitor are connected between the FB pin and the IN- pin.
7	AGND	Analog GND pin
8	PGND	Power GND pin
—	Exposed PAD	Connect to GND (only HSOP8 PKG)

### ■ Description of Block Features

#### 1. Basic Functions / Features

##### ● Error Amplifier Section (ER-AMP)

1.0V±1% precise reference voltage is connected to the non-inverted input of this section.

To set the output voltage, connects converter's output to inverted input of this section (IN- pin). If requires output voltage, inserts resistor divider.

This AMP section has high gain and external feedback pin (FB pin). It is easy to insert a feedback resistor and a capacitor between the FB pin and the IN- pin, making possible to set optimum loop compensation for each type of application.

##### ● Oscillation Circuit Section (OSC)

Oscillation frequency can be set by inserting resistor between the RT pin and GND. Referring to the sample characteristics in "Timing Resistor and Oscillation Frequency", set oscillation between 300kHz and 1MHz.

### ■ Description of Block Features (Continued)

#### ● PWM Comparator Section (PWM)

This section controls the switching duty ratio.

PWM comparator receives the signal of the error amplifier and the triangular wave, and controls the duty ratio between 0% and 90% (typ.). The timing chart is shown in Fig.1.

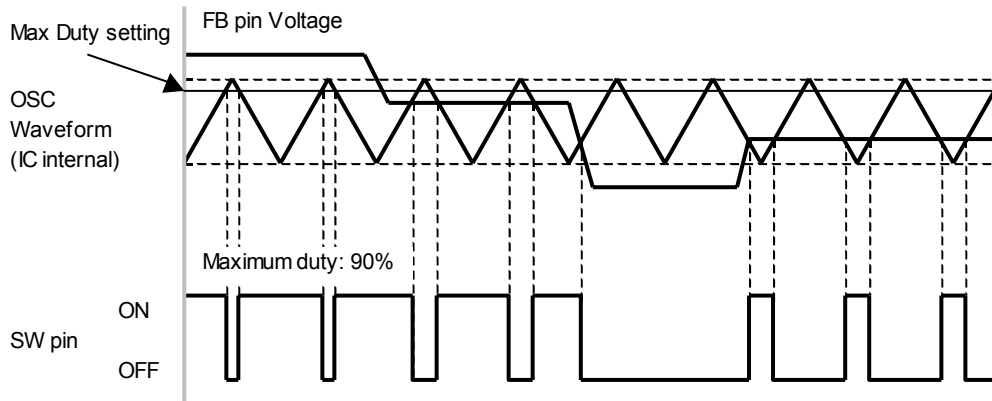

Fig. 1. Timing Chart PWM Comparator and SW pin

#### ● Power MOSFET (SW Output Section)

The power is stored in the inductor by the switch operation of built-in power MOSFET. The output current is limited to 1.4A(min.) @A version and 1.0A(min.) @B version by the overcurrent protection function.

#### ● Power Supply, GND pin ( $V^+$ and PGND, AGND)

In line with switching element drive, current flows into the IC according to frequency. If the power supply impedance provided to the power supply circuit is high, it will not be possible to take advantage of IC performance due to input voltage fluctuation. Therefore insert a bypass capacitor close to the  $V^+$  pin – the AGND pin connection in order to lower high frequency impedance.

### ■ Description of Block Features (Continued)

#### 2. Additional and Protection Functions / Features

##### ● Under Voltage Lockout (UVLO)

The UVLO circuit operating is released above  $V^+ = 3.9V(\text{typ.})$  and IC operation starts. When power supply voltage is low, IC does not operate because the UVLO circuit operates. There is 100mV width hysteresis voltage at rise and decay of power supply voltage. Hysteresis prevents the malfunction at the time of UVLO operating and releasing.

##### ● Soft Start Function (Soft Start)

The output voltage of the converter gradually rises to a set value by the soft start function. The soft start time is 4ms (typ). It is defined with the time of the error amplifier reference voltage becoming from 0V to 0.95V. The soft start circuit operates after the release UVLO and/or recovery from thermal shutdown. The operating frequency is controlled with a low frequency, approximately 40% of the set value by the timing resistor, until voltage of the IN- pin becomes approximately 0.4V.

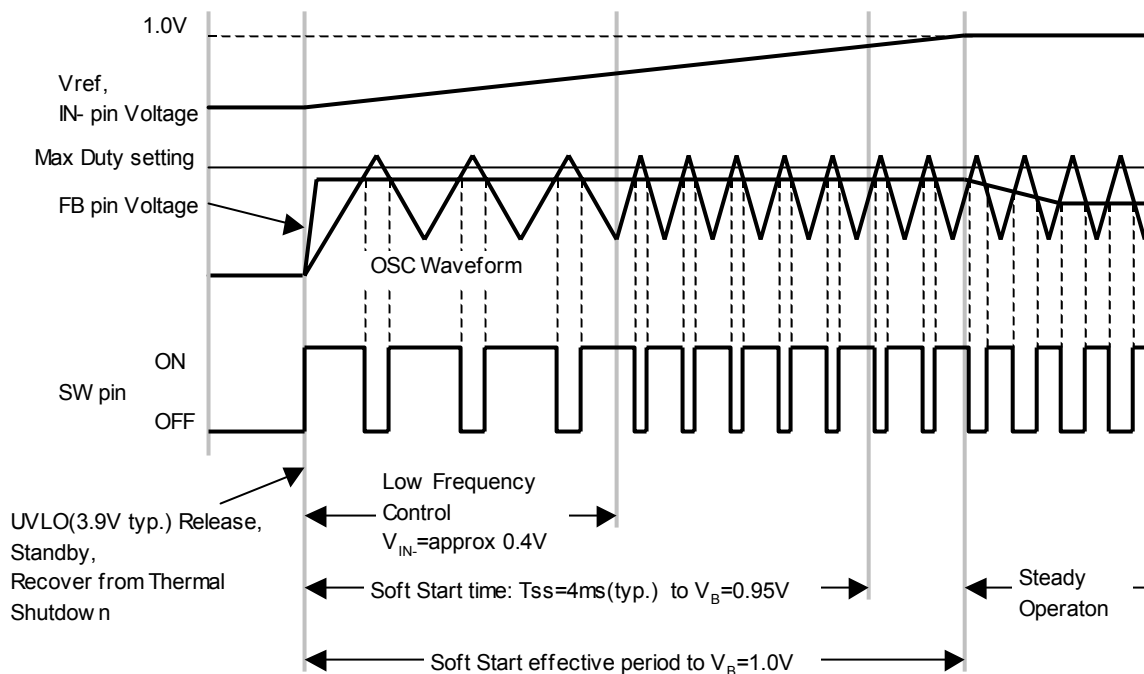

Fig. 2. Startup Timing Chart

### ■ Description of Block Features (Continued)

#### ● Over Current Protection Circuit (OCP)

At when the switching current becomes  $I_{LIM}$  or more, the overcurrent protection circuit is stopped the MOSFET output. The switching output holds low level down to next pulse output at OCP operating.

The NJW4131 output returns automatically along with release from the over current condition because the OCP is pulse-by-pulse type.

Fig.3. shows the timing chart of the over current protection detection.

If voltage of the IN- pin becomes less than 0.4V, the oscillation frequency decreases to approximately 40% and the energy consumption is suppressed.

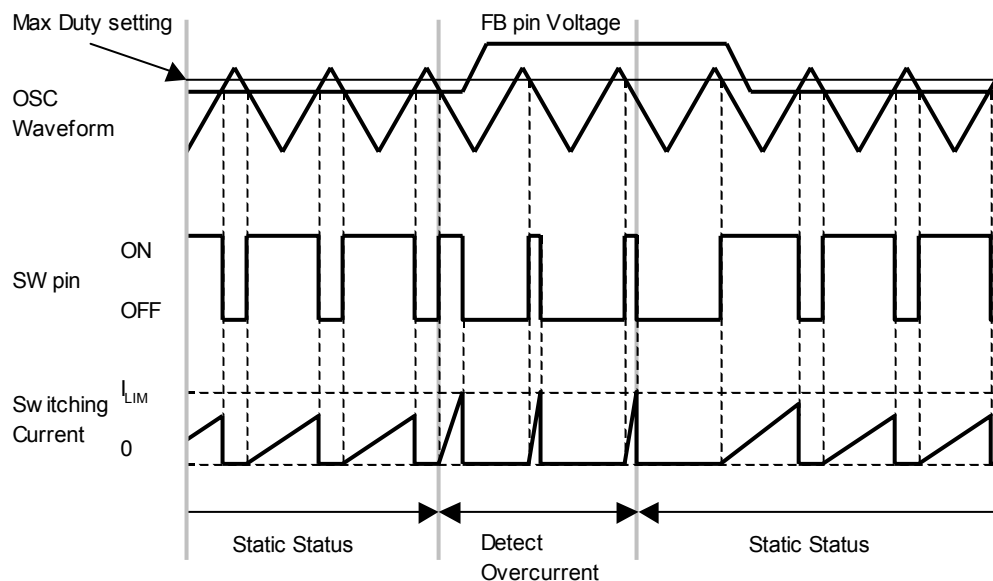

Fig3. Timing Chart at Over Current Detection

If temperature increases, switching current limit ( $I_{LIM}$ ) decreases due to thermal characteristics (see characteristics "Limited Switching Current vs. Temperature"). You should consider application temperature and set a peak current less than switching current limit.

#### ● Thermal Shutdown Function (TSD)

When Junction temperature of the NJW4131 exceeds the 170°C\*, internal thermal shutdown circuit function stops SW function. When junction temperature decreases to 150°C\* or less, SW operation returns with soft start operation.

The purpose of this function is to prevent malfunctioning of IC at the high junction temperature. Therefore it is not something that urges positive use. You should make sure to operate within the junction temperature range rated (150°C). (\* Design value)

#### ● ON/OFF Function (Standby Control)

The NJW4131 stops the operating and becomes standby status when the ON/OFF pin becomes less than 0.5V.

The ON/OFF pin internally pulls down with 400kΩ, therefore the NJW4131 becomes standby mode when the ON/OFF pin is OPEN. You should connect this pin to  $V^+$  when you do not use ON/OFF function.

### ■ Application Information

#### ● Inductors

Large currents flow into inductor, therefore you must provide current capacity that does not saturate.

Reducing  $L$ , the size of the inductor can be smaller. However, peak current increases and adversely affecting efficiency.

On the other hand, increasing  $L$ , peak current can be reduced at switching time. Therefore conversion efficiency improves, and output ripple voltage reduces. Above a certain level, increasing inductance windings increases loss (copper loss) due to the resistor element.

Ideally, the value of  $L$  is set so that inductance current is in continuous conduction mode. However, as the load current decreases, the current waveform changes from (1) CCM: Continuous Conduction Mode  $\rightarrow$  (2) Critical Mode  $\rightarrow$  (3) DCM: Discontinuous Conduction Mode (Fig. 4.).

In discontinuous mode, peak current increases with respect to output current, and conversion efficiency tend to decrease. Depending on the situation, increase  $L$  to widen the load current area to maintain continuous mode.

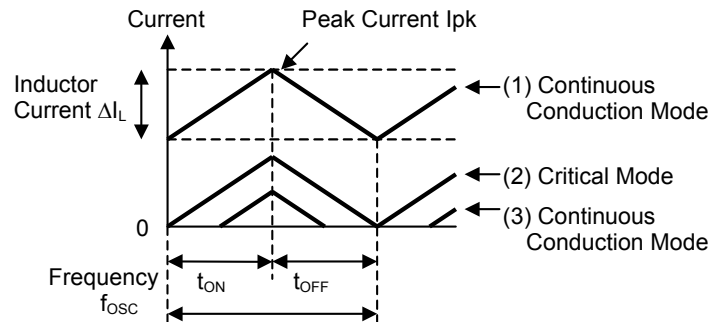

Fig. 4. Inductor Current State Transition

#### ● Catch Diode

When the switch element is in OFF cycle, power stored in the inductor flows via the catch diode to the output capacitor. Therefore during each cycle current flows to the diode in response to load current. Because diode's forward saturation voltage and current accumulation cause power loss, a Schottky Barrier Diode (SBD), which has a low forward saturation voltage, is ideal.

An SBD also has a short reverse recovery time. If the reverse recovery time is long, through current flows when the switching transistor transitions from OFF cycle to ON cycle. This current may lower efficiency and affect such factors as noise generation.

When the switch element is in ON cycle, a reverse voltage flows to SBD. Therefore you should select a SBD that has reverse voltage rating greater than maximum output voltage. The power loss, which stored in output capacitor, will be increase due to increasing reverse current through SBD at high temperature. Therefore, there is cases preferring reverse current characteristics to forward current characteristic in order to improve efficiency.

#### ● Input Capacitor

Transient current flows into the input section of a switching regulator responsive to frequency. If the power supply impedance provided to the power supply circuit is large, it will not be possible to take advantage of NJW4131 performance due to input voltage fluctuation. Therefore insert an input capacitor as close to the MOSFET as possible.

#### ● Output Capacitor

An output capacitor stores power from the inductor, and stabilizes voltage provided to the output.

When selecting an output capacitor, you must consider Equivalent Series Resistance (ESR) characteristics, ripple current, and breakdown voltage.

Also, the ambient temperature affects capacitors, decreasing capacitance and increasing ESR (at low temperature), and decreasing lifetime (at high temperature). Concerning capacitor rating, it is advisable to allow sufficient margin.

Output capacitor ESR characteristics have a major influence on output ripple noise. A capacitor with low ESR can further reduce ripple voltage. Be sure to note the following points; when ceramic capacitor is used, the capacitance value decreases with DC voltage applied to the capacitor.

### ■ Application Information (Continued)

#### ● Board Layout

In the switching regulator application, because the current flow corresponds to the oscillation frequency, the substrate (PCB) layout becomes an important.

You should attempt the transition voltage decrease by making a current loop area minimize as much as possible. Therefore, you should make a current flowing line thick and short as much as possible. Fig.5. shows a current loop at Boost converter.

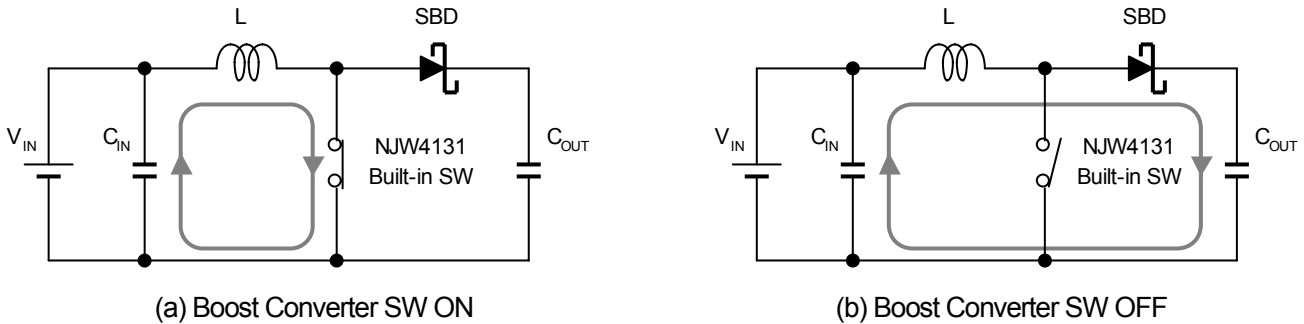

Fig. 5. Current Loop at Boost Converter

Concerning the GND line, it is preferred to separate the power system and the signal system, and use single ground point.

The voltage sensing feedback line should be as far away as possible from the inductance. Because this line has high impedance, it is laid out to avoid the influence noise caused by flux leaked from the inductance.

Fig. 6. shows example of wiring at boost converter. Fig. 7 shows the PCB layout example.

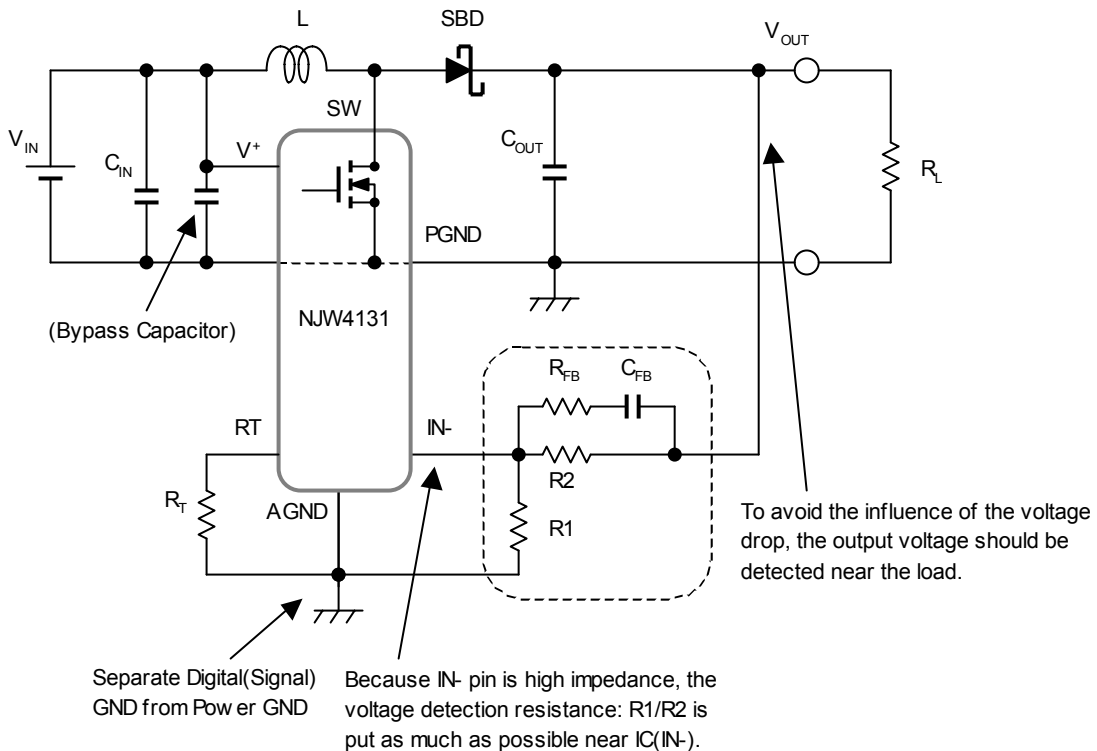
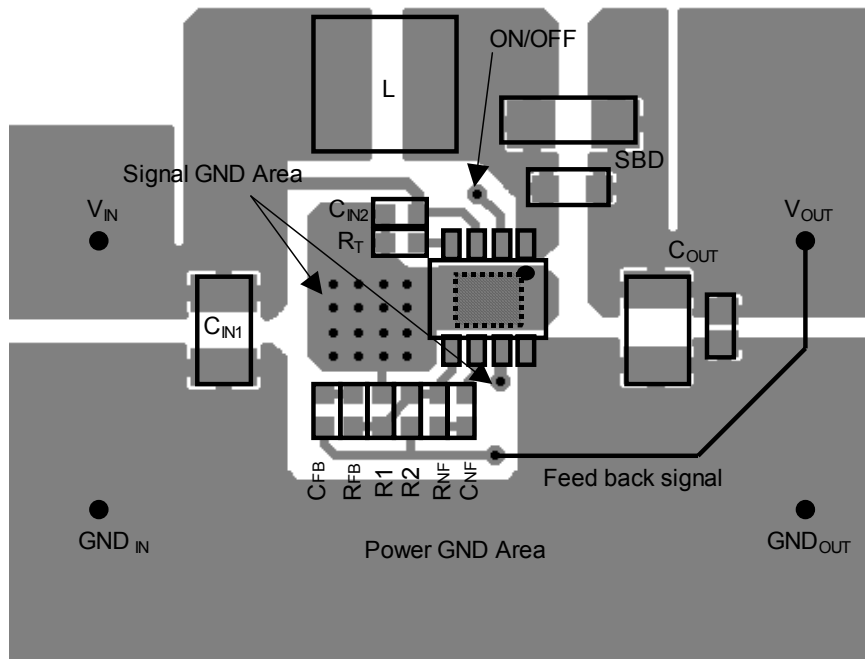

Fig. 6. Board Layout at Boost Converter

### ■ Application Information (Continued)



Connect Signal GND line and Power GND line on backside pattern

Fig. 7 Layout Example (upper view)

### ■ Calculation of Package Power

A lot of the power consumption of boost converter occurs from the internal switching element (Power MOSFET). Power consumption of NJW4131 is roughly estimated as follows.

$$\begin{aligned} \text{Input Power:} & P_{IN} = V_{IN} \times I_{IN} \quad [W] \\ \text{Output Power:} & P_{OUT} = V_{OUT} \times I_{OUT} \quad [W] \\ \text{Diode Loss:} & P_{DIODE} = V_F \times I_{L(avg)} \times \text{OFF duty} \quad [W] \\ \text{NJW4131 Power Consumption:} & P_{LOSS} = P_{IN} - P_{OUT} - P_{DIODE} \quad [W] \end{aligned}$$

Where:

$V_{IN}$	: Input Voltage for Converter	$I_{IN}$	: Input Current for Converter
$V_{OUT}$	: Output Voltage of Converter	$I_{OUT}$	: Output Current of Converter
$V_F$	: Diode's Forward Saturation Voltage	$I_{L(avg)}$	: Inductor Average Current
OFF duty	: Switch OFF Duty		

Efficiency ( $\eta$ ) is calculated as follows.

$$\eta = (P_{OUT} \div P_{IN}) \times 100 \quad [\%]$$

You should consider temperature derating to the calculated power consumption:  $P_D$ .

You should design power consumption in rated range referring to the power dissipation vs. ambient temperature characteristics (Fig. 8).

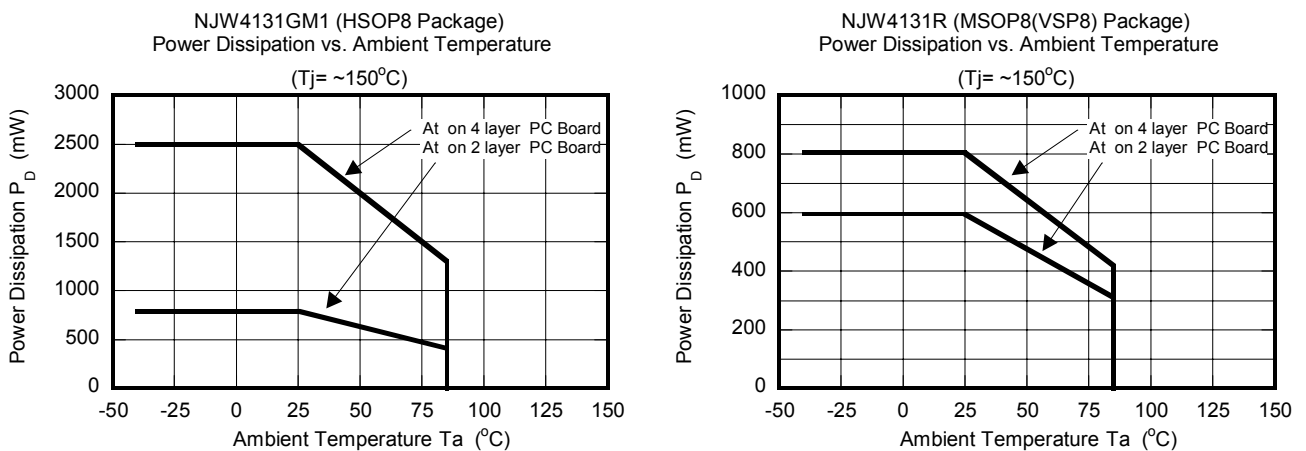

Mounted on glass epoxy board. (76.2×114.3×1.6mm:EIA/JDEC standard size, 2Layers)

Mounted on glass epoxy board. (76.2×114.3×1.6mm:EIA/JDEC standard size, 4Layers),

internal Cu area: 74.2×74.2mm

Fig.8. Power Dissipation vs. Ambient Temperature Characteristics



### Application Design Examples

#### Step-Up Application Circuit

IC : NJW4131GM1-A  
 Input Voltage :  $V_{IN}=12V$   
 Output Voltage :  $V_{OUT}=24V$   
 Output Current :  $I_{OUT}=0.3A$   
 Oscillation frequency :  $f_{osc}=700kHz$

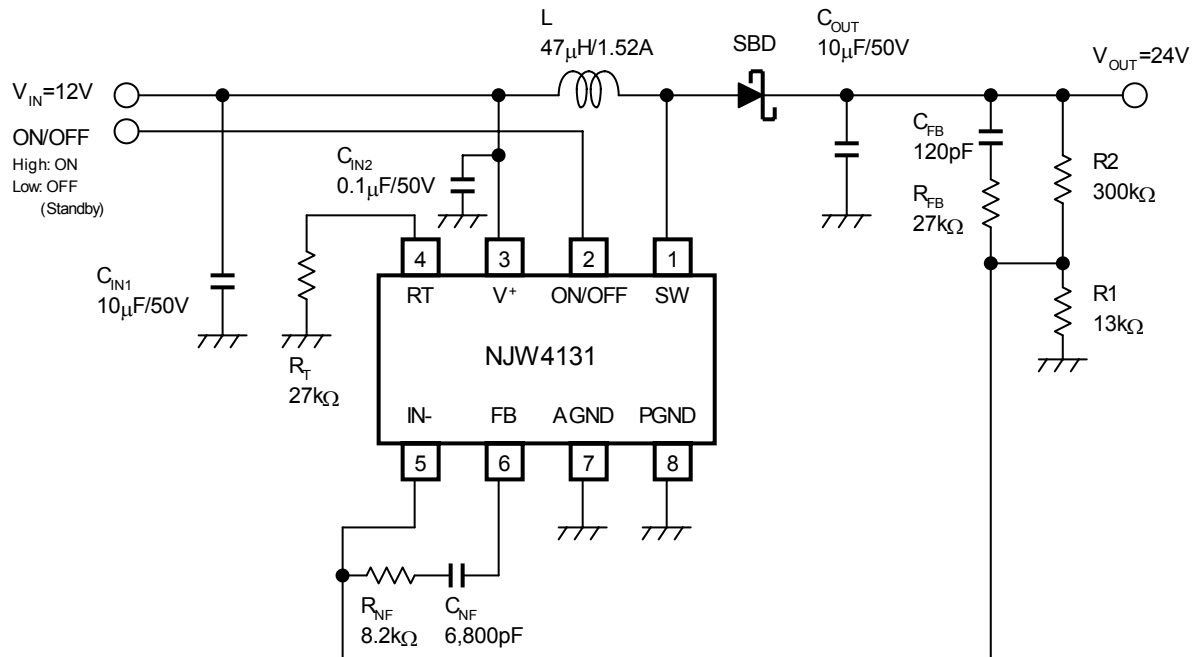

Reference	Qty.	Part Number	Description	Manufacturer
IC	1	NJW4131GM1-A	Internal 40V MOSFET SW.REG. IC	New JRC
L	1	CDRH8D38NP-470N	Inductor 47µH, 1.52A	Sumida
D	1	CMS11	Schottky Diode 40V, 2A	Toshiba
$C_{IN1}, C_{OUT}$	2	UMK325BJ106MM	Ceramic Capacitor 3225 10µF, 50V, X5R	Taiyo Yuden
$C_{IN2}$	1	0.1µF	Ceramic Capacitor 1608 0.1µF, 50V, B	Std.
$C_{NF}$	1	6,800pF	Ceramic Capacitor 1608 6,800pF, 50V, B	Std.
$C_{FB}$	1	120pF	Ceramic Capacitor 1608 120pF, 50V, CH	Std.
R1	1	13kΩ	Resistor 1608 13kΩ, ±1%, 0.1W	Std.
R2	1	300kΩ	Resistor 1608 300kΩ, ±1%, 0.1W	Std.
$R_T$	1	27kΩ	Resistor 1608 27kΩ, ±1%, 0.1W	Std.
$R_{NF}$	1	8.2kΩ	Resistor 1608 8.2kΩ, ±5%, 0.1W	Std.
$R_{FB}$	1	27kΩ	Resistor 1608 27kΩ, ±5%, 0.1W	Std.

### ■ Application Design Examples (Continued)

#### ● Setting Oscillation Frequency

From the Oscillation frequency vs. Timing Resistor Characteristic,  $R_T=27$  [k $\Omega$ ],  $t=1.43$  [ $\mu$ s] at  $f_{osc}=700$ kHz.

Step-Up converter duty ratio is shown with the following equation.

$$\text{Duty} = \left(1 - \frac{V_{IN}}{V_{OUT}}\right) \times 100 = \left(1 - \frac{12}{24}\right) \times 100 = 50 \text{ [\%]}$$

Therefore,  $t_{ON}=0.72$  [ $\mu$ s],  $t_{OFF}=0.71$  [ $\mu$ s]

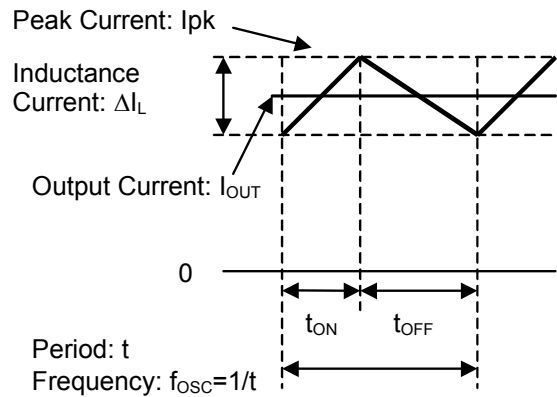

Fig. 9. Inductor Current Waveform

#### ● Selecting Inductance

The inductor's average current equals input current ( $I_{IN}$ ). Estimated efficiency ( $\eta$ ) is 90% and calculates input current.

$$I_{IN} = \frac{V_{OUT} \times I_{OUT}}{\eta \times V_{IN}} = \frac{24 \times 0.3}{0.9 \times 12} = 0.67 \text{ [A]}$$

To assume maximum output current: 0.3A, and the inductor ripple current should be set not to exceed the minimum switching limiting current:  $I_{LIM}=1.4$ A (min.).

$\Delta I_L$  is Inductance ripple current. When to  $\Delta I_L =$  input current 30%:

$$\Delta I_L = 0.3 \times I_{IN} = 0.3 \times 0.67 = 0.2 \text{ [A]}$$

This obtains inductance L.

$$L = \frac{V_{IN}}{\Delta I_L} \times t_{ON} = \frac{12}{0.2} \times 0.72 \mu = 43.2 \Rightarrow 47 \text{ [\mu H]}$$

Inductance L is a theoretical value. The optimum value varies according such factors as application specifications and components. Fine-tuning should be done on the actual device.

This obtains the peak current  $I_{pk}$  at switching time.

$$I_{pk} = I_{IN} + \frac{\Delta I_L}{2} = 0.67 + \frac{0.2}{2} = 0.77 \text{ [A]}$$

The current that flows into the inductance provides sufficient margin for peak current at switching time. In the application circuit, use  $L=47$  $\mu$ H, 1.52A.

### ■ Application Design Examples (Continued)

#### ● Selecting the Output Capacitor

The output capacitor is an important component that determines output ripple noise. Equivalent Series Resistance (ESR), ripple current, and capacitor breakdown voltage are important in determining the output capacitor.

The output ripple noise can be expressed by the following formula.

$$ESR = \frac{V_{ripple(p-p)}}{\Delta I_L}$$

When selecting output capacitance, select a capacitor that allows for sufficient ripple current.

The effective ripple current that flows in a capacitor ( $I_{rms}$ ) is obtained by the following equation.

$$I_{rms} = \sqrt{I_{PK}^2 - I_{OUT}^2} = \sqrt{0.77^2 - 0.3^2} = 0.71 \text{ [Arms]}$$

Consider sufficient margin, and use a capacitor that fulfills the above spec.

In the application circuit, use  $C_{OUT}=10\mu\text{F}/50\text{V}$ .

#### ● Setting Output Voltage

The output voltage  $V_{OUT}$  is determined by the relative resistances of R1, R2. The current that flows in R1, R2 must be a value that can ignore the bias current that flows in ER AMP.

$$V_{OUT} = \left( \frac{R2}{R1} + 1 \right) \times V_B = \left( \frac{300k}{13k} + 1 \right) \times 1 = 24.07 \text{ [V]}$$

It is easy to make a feedback loop, because the error amplifier output connects to FB pin. DC gain affects voltage sensing of the error amplifier. If AC gain increases, it affects stability of regulator due to AC gain which contains switching noise, ripple noise and the others.

Recommended way of feedback, is high DC gain and low AC gain.

In this application, a feedback resistor  $R_{NF}=8.2k\Omega$  and capacitor  $C_{NF}=6,800\text{pF}$  are connected in serial.

However, if the AC gain is lowered too much, it happens slower transient response against fast load changes. The optimum value varies according such factors as application specifications and components. Fine-tuning should be done on the actual device.

### ■ Application Characteristics :NJW4131GM1-A

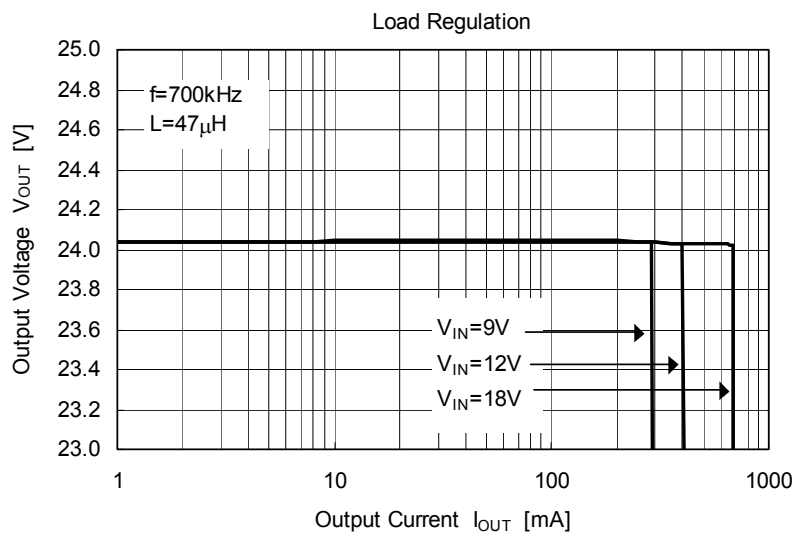
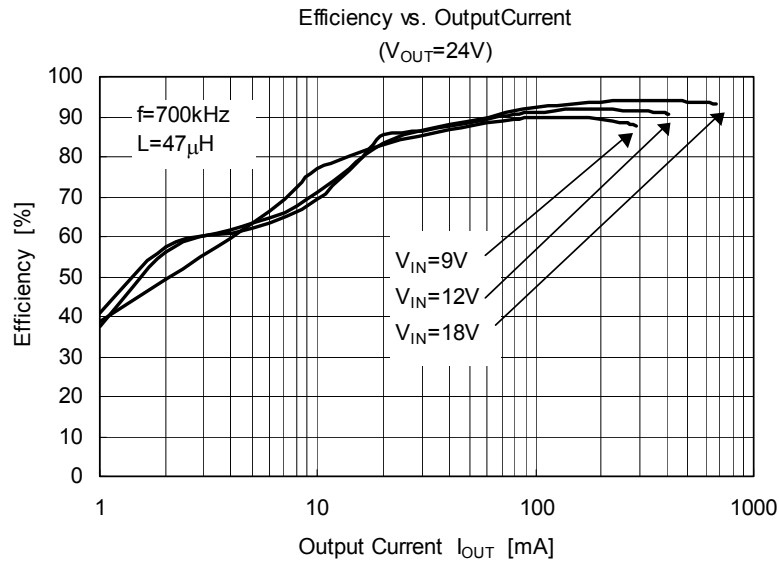

**[CAUTION]**

The specifications on this databook are only given for information, without any guarantee as regards either mistakes or omissions. The application circuits in this databook are described only to show representative usages of the product and not intended for the guarantee or permission of any right including the industrial rights.

## X-ON Electronics

Largest Supplier of Electrical and Electronic Components

*Click to view similar products for [LDO Voltage Regulators](#) category:*

*Click to view products by [Nisshinbo](#) manufacturer:*

Other Similar products are found below :

[AP7363-SP-13](#) [NCV8664CST33T3G](#) [L79M05TL-E](#) [AP7362-HA-7](#) [PT7M8202B12TA5EX](#) [TCR3DF185,LM\(CT](#) [TLF4949EJ](#)  
[NCP4687DH15T1G](#) [NCV8703MX30TCG](#) [LP2951CN](#) [NCV4269CPD50R2G](#) [AP7315-25W5-7](#) [NCV47411PAAJR2G](#) [AP2111H-1.2TRG1](#)  
[ZLDO1117QK50TC](#) [AZ1117ID-ADJTRG1](#) [NCV4263-2CPD50R2G](#) [NCP706ABMX300TAG](#) [NCP114BMX075TCG](#) [MC33269T-3.5G](#)  
[TLE4471GXT](#) [AP7315-33SA-7](#) [NCV4266-2CST33T3G](#) [NCP715SQ15T2G](#) [NCV8623MN-50R2G](#) [NCV563SQ18T1G](#) [NCV8664CDT33RKG](#)  
[NCV4299CD250R2G](#) [NCP715MX30TBG](#) [NCV8702MX25TCG](#) [TLE7270-2E](#) [NCV562SQ25T1G](#) [AP2213D-3.3TRG1](#) [AP2202K-2.6TRE1](#)  
[NCV8170BMX300TCG](#) [NCV8152MX300180TCG](#) [NCP700CMT45TBG](#) [AP7315-33W5-7](#) [NCP154MX180300TAG](#) [AP2113AMTR-G1](#)  
[NJW4104U2-33A-TE1](#) [MP2013AGG-5-P](#) [NCV8775CDT50RKG](#) [NJM2878F3-45-TE1](#) [S-19214B00A-V5T2U7](#) [S-19214B50A-V5T2U7](#) [S-](#)  
[19213B50A-V5T2U7](#) [S-19214BC0A-E8T1U7\\*1](#) [S-19213B00A-V5T2U7](#) [S-19213B33A-V5T2U7](#)