

■ PIN CONFIGURATION

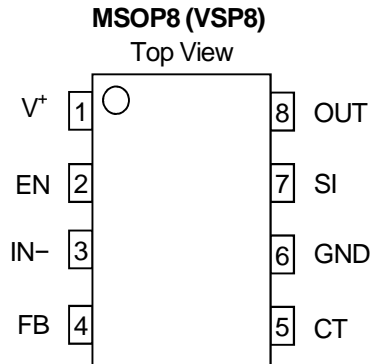

PIN NO.	NAME	FUNCTION
1	V ⁺	Power supply pin
2	EN	Enable control pin
3	IN-	Output voltage detecting pin
4	FB	Feedback setting pin
5	CT	Oscillating frequency setting pin
6	GND	Ground pin
7	SI	Current sensing pin
8	OUT	Output pin

■ PRODUCT NAME INFORMATION

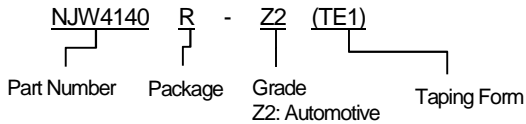

■ ORDERING INFORMATION

PRODUCT NAME	PACKAGE	RoHS	HALOGEN-FREE	TERMINAL FINISH	MARKING	WEIGHT (mg)	MOQ (pcs)
NJW4140R-Z2 (TE1)	MSOP8 (VSP8)	Yes	Yes	Sn-2Bi	4140Z2	21	2000

■ ABSOLUTE MAXIMUM RATINGS

PARAMETER	SYMBOL	RATING	UNIT
Input Voltage	V^+	45	V
OUT pin Voltage	V_{OUT}	-0.3 to 6 ⁽¹⁾	V
SI pin Voltage	V_{SI}	-0.3 to 6	V
EN pin Voltage	V_{EN}	45	V
IN- pin Voltage	V_{IN-}	6	V
CT pin Voltage	V_{CT}	6 ⁽¹⁾	V
OUT pin Peak Current	I_{O_PEAK+} I_{O_PEAK-}	200 (Source) 700 (Sink)	mA
Power Dissipation ($T_a = 25^\circ\text{C}$) MSOP8 (VSP8)	P_D	2-Layer 595 ⁽²⁾	mW
Junction Temperature	T_j	-40 to 150	$^\circ\text{C}$
Storage Temperature	T_{stg}	-40 to 150	$^\circ\text{C}$

(1) When Input voltage is less than 6V, the absolute maximum these pin are equal to the Input voltage.

(2) 2-Layer: Mounted on glass epoxy board (76.2 mm × 114.3 mm × 1.6 mm: based on EIA/JEDEC standard, 2-layer FR-4).

■ RECOMMENDED OPERATING CONDITIONS

PARAMETER	SYMBOL	VALUE	UNIT
Supply Voltage	V^+	3 to 40	V
Timing Capacitor	C_T	120 to 3900	pF
Oscillating Frequency	f_{osc}	40 to 1000	kHz
Operating Temperature	T_{opr}	-40 to 125	$^\circ\text{C}$

■ ELECTRICAL CHARACTERISTICS

$V^+ = V_{EN} = 12V$, $C_T = 470pF$, $T_a = 25^\circ C$, unless otherwise noted.

PARAMETER	SYMBOL	TEST CONDITIONS	MIN	TYP	MAX	UNIT
OSCILLATOR						
Oscillation Frequency 1	f_{OSC1}	$C_T = 470pF$	270	300	330	kHz
		$C_T = 470pF$, $T_a = -40^\circ C$ to $125^\circ C$	260	-	330	
Oscillation Frequency 2	f_{OSC2}	$C_T = 680pF$	180	210	240	kHz
		$C_T = 680pF$, $T_a = -40^\circ C$ to $125^\circ C$	170	-	240	
Oscillation Frequency 3	f_{OSC3}	$C_T = 1500pF$	92	100	110	kHz
		$C_T = 1500pF$, $T_a = -40^\circ C$ to $125^\circ C$	85	-	110	
Charge Current	I_{chg}		150	200	250	μA
		$T_a = -40^\circ C$ to $125^\circ C$	140	-	260	
Discharge Current	I_{dis}		150	200	250	μA
		$T_a = -40^\circ C$ to $125^\circ C$	140	-	260	
Voltage Amplitude	V_{OSC}		-	0.7	-	V
Oscillation Frequency Deviation (Supply Voltage)	f_{DV}	$V^+ = 3V$ to $40V$	-	1	-	%
Oscillation Frequency (Low Frequency Control)	f_{OSC_LOW}	$V_{IN-} = 0.3V$, $V_{FB} = 0.7V$, $C_T = 470pF$	90	105	120	kHz
		$V_{IN-} = 0.3V$, $V_{FB} = 0.7V$, $C_T = 470pF$, $T_a = -40^\circ C$ to $125^\circ C$	70	-	130	
SOFT START						
Soft Start Time	T_{SS}	$V_B = 0.75V$	2	4	8	ms
		$V_B = 0.75V$, $T_a = -40^\circ C$ to $125^\circ C$	2	-	8	
ERROR AMPLIFIER						
Reference Voltage	V_B		-1.0%	0.8	+1.0%	V
		$T_a = -40^\circ C$ to $125^\circ C$	-2.0%	-	+2.0%	
Input Bias Current	I_B		-0.1	-	0.1	μA
		$T_a = -40^\circ C$ to $125^\circ C$	-0.1	-	0.1	
Open Loop Gain	A_V		-	80	-	dB
Gain Bandwidth Product	G_B		-	3	-	MHz
Output Source Current	I_{OM+}	$V_{FB} = 1V$, $V_{IN-} = 0.7V$	50	100	150	μA
		$V_{FB} = 1V$, $V_{IN-} = 0.7V$, $T_a = -40^\circ C$ to $125^\circ C$	50	-	150	
Output Sink Current	I_{OM-}	$V_{FB} = 1V$, $V_{IN-} = 0.9V$	2	4	6	mA
		$V_{FB} = 1V$, $V_{IN-} = 0.9V$, $T_a = -40^\circ C$ to $125^\circ C$	2	-	8	
PWM COMPARATOR						
Input Threshold Voltage (FB pin)	V_{T_0}	Duty = 0%, $V_{IN-} = 0.6V$	0.32	0.40	0.54	V
		Duty = 0%, $V_{IN-} = 0.6V$, $T_a = -40^\circ C$ to $125^\circ C$	0.32	-	0.54	
	V_{T_50}	Duty = 50%, $V_{IN-} = 0.6V$	0.63	0.70	0.77	V
		Duty = 50%, $V_{IN-} = 0.6V$, $T_a = -40^\circ C$ to $125^\circ C$	0.63	-	0.77	
Maximum Duty Cycle	M_{AXDUTY}	$V_{FB} = 1.2V$	85	90	95	%
		$V_{FB} = 1.2V$, $T_a = -40^\circ C$ to $125^\circ C$	85	-	95	

■ ELECTRICAL CHARACTERISTICS

$V^+ = V_{EN} = 12V$, $C_T = 470pF$, $T_a = 25^\circ C$, unless otherwise noted.

PARAMETER	SYMBOL	TEST CONDITIONS	MIN	TYP	MAX	UNIT
CURRENT LIMIT DETECTION						
Current Limit Detection Voltage	V_{IPK}		120	140	160	mV
		$T_a = -40^\circ C$ to $125^\circ C$	120	-	160	
Delay Time	T_{DELAY}	$\Delta V_{SI} = 300mV$	-	90	-	ns
OUTPUT						
Output High Level ON Resistance	R_{OH}	$I_o = -50mA$	-	3.0	4.5	Ω
Output Low Level ON Resistance	R_{OL}	$I_o = 50mA$	-	2.5	3.5	Ω
		$I_o = 50mA$, $T_a = -40^\circ C$ to $125^\circ C$	-	-	4.5	
Output Source Current	I_{OH}	OUT pin = 4.5V	45	65	85	mA
		OUT pin = 4.5V, $T_a = -40^\circ C$ to $125^\circ C$	40	-	90	
Output pin Limiting Voltage	V_{OLIM}		5.00	5.30	5.55	V
		$T_a = -40^\circ C$ to $125^\circ C$	5.00	-	5.65	
UNDER VOLTAGE LOCKOUT						
ON Threshold Voltage	V_{T_ON}	$V^+ = L \rightarrow H$	2.65	2.80	2.95	V
		$V^+ = L \rightarrow H$, $T_a = -40^\circ C$ to $125^\circ C$	2.65	-	2.95	
OFF Threshold Voltage	V_{T_OFF}	$V^+ = H \rightarrow L$	2.40	2.55	2.70	V
		$V^+ = H \rightarrow L$, $T_a = -40^\circ C$ to $125^\circ C$	2.35	-	2.80	
ENABLE CONTROL						
ON Control Voltage	V_{ON}	$V_{EN} = L \rightarrow H$	1.7	-	V^+	V
		$V_{EN} = L \rightarrow H$, $T_a = -40^\circ C$ to $125^\circ C$	1.7	-	V^+	
OFF Control Voltage	V_{OFF}	$V_{EN} = H \rightarrow L$	0	-	0.9	V
		$V_{EN} = H \rightarrow L$, $T_a = -40^\circ C$ to $125^\circ C$	0	-	0.9	
Pull-down Resistance	R_{PD}		350	500	650	k Ω
		$T_a = -40^\circ C$ to $125^\circ C$	350	-	650	
GENERAL CHARACTERISTICS						
Quiescent Current	I_{DD}	$R_L = \text{no load}$, $V_{IN-} = V_{FB} = 0.7V$	-	1.4	1.7	mA
		$R_L = \text{no load}$, $V_{IN-} = V_{FB} = 0.7V$, $T_a = -40^\circ C$ to $125^\circ C$	-	-	2.0	
Standby Current	I_{DD_STB}	$V_{EN} = 0V$	-	2.5	6.0	μA
		$V_{EN} = 0V$, $T_a = -40^\circ C$ to $125^\circ C$	-	-	12.0	

■ POWER DISSIPATION vs. AMBIENT TEMPERATURE

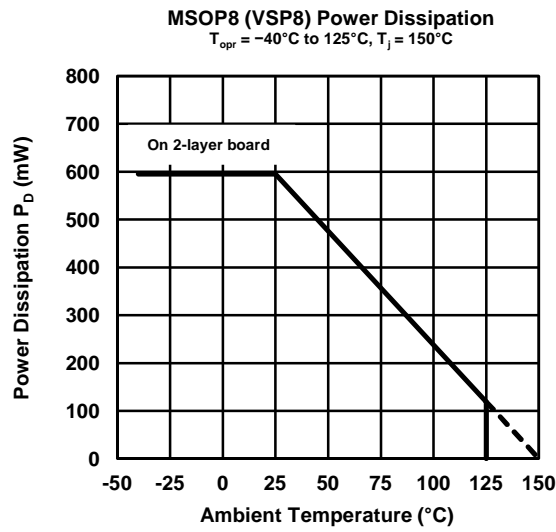

2-Layer: Mounted on glass epoxy board (76.2 mm x 114.3 mm x 1.6 mm: based on EIA/JEDEC standard, 2-layer FR-4).

■ APPLICATION EXAMPLE

Non-isolated Boost Converter

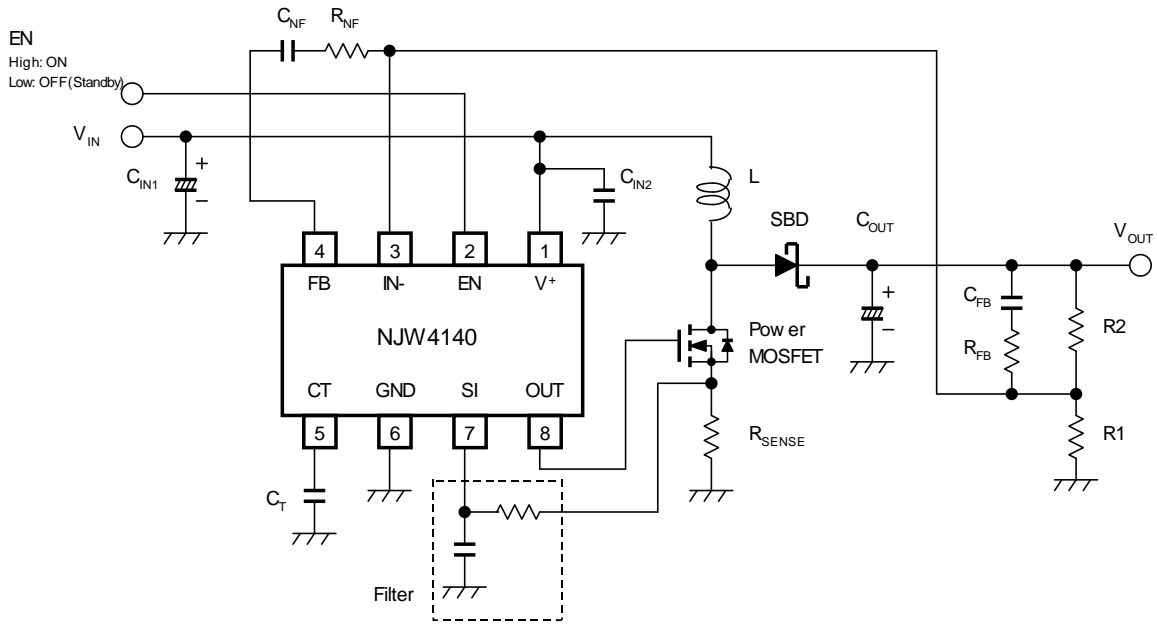

Non-isolated Fly-back Converter

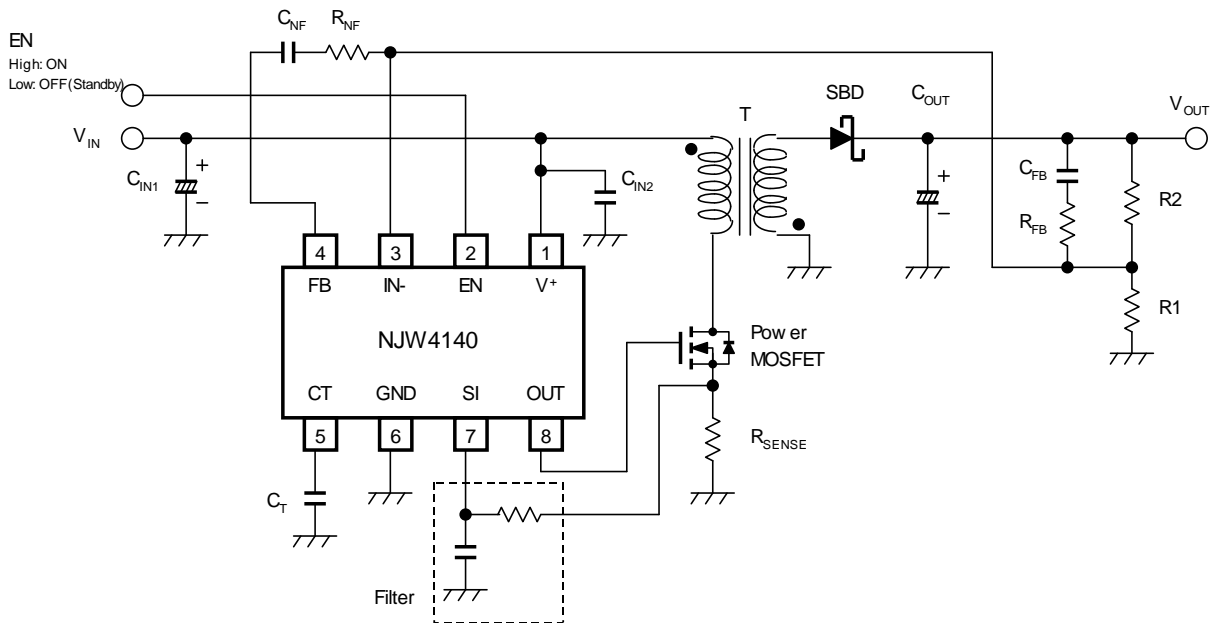

■ TYPICAL CHARACTERISTICS

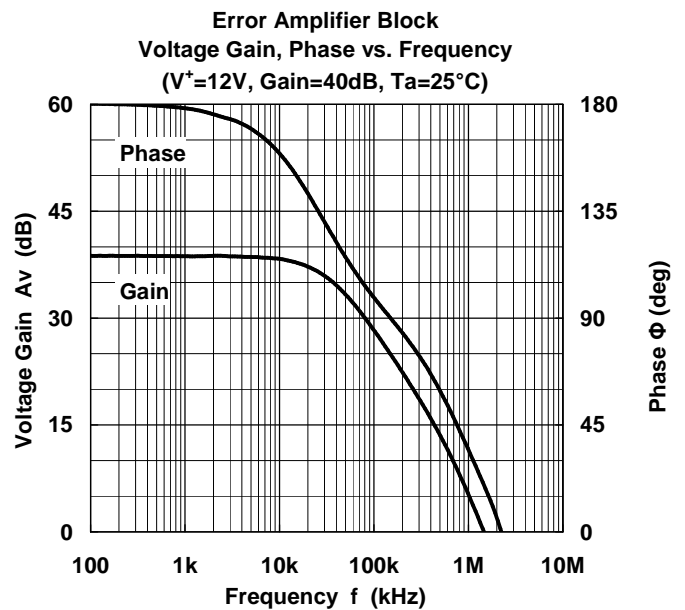
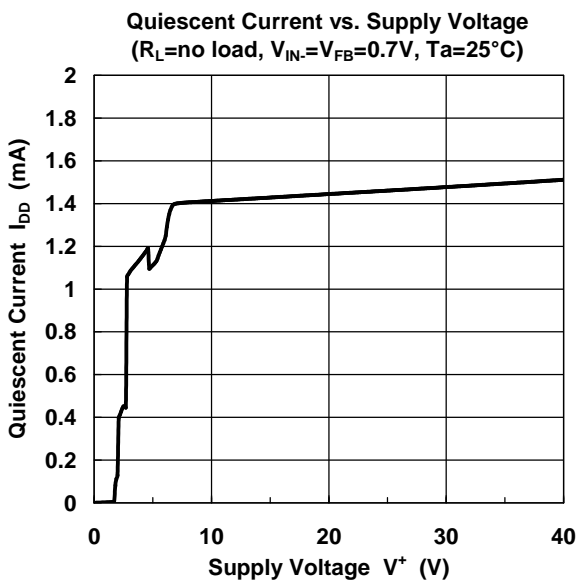
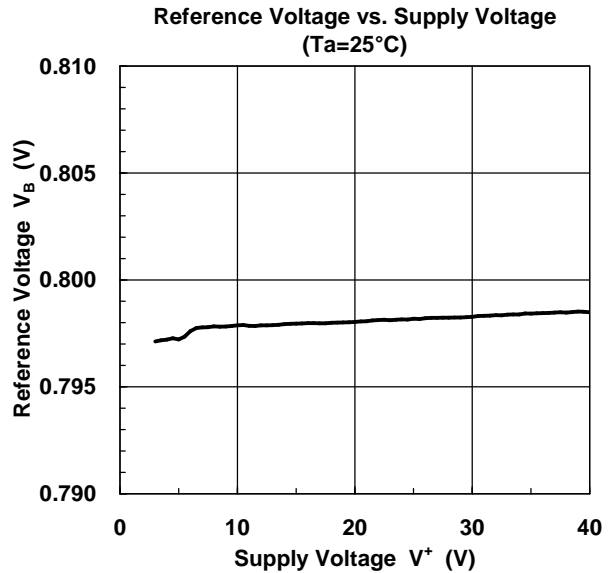
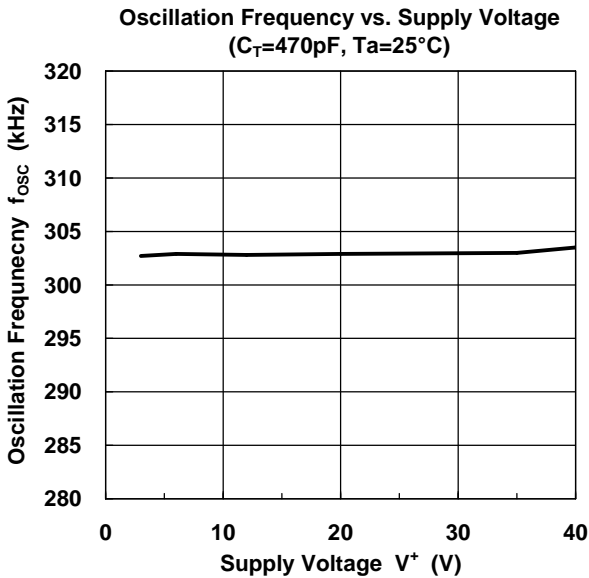
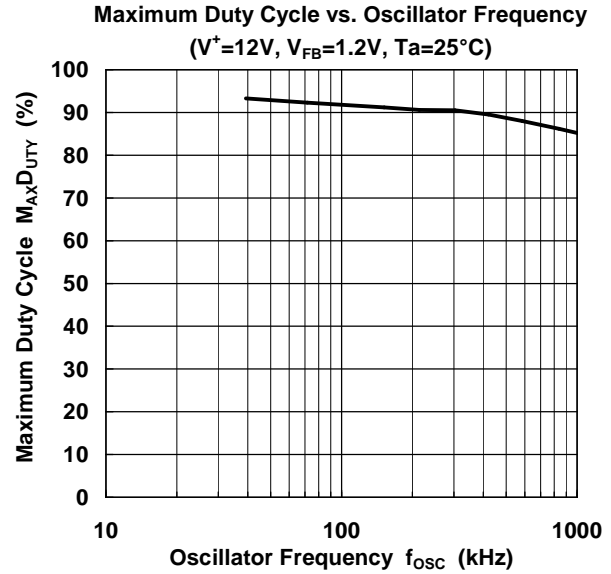
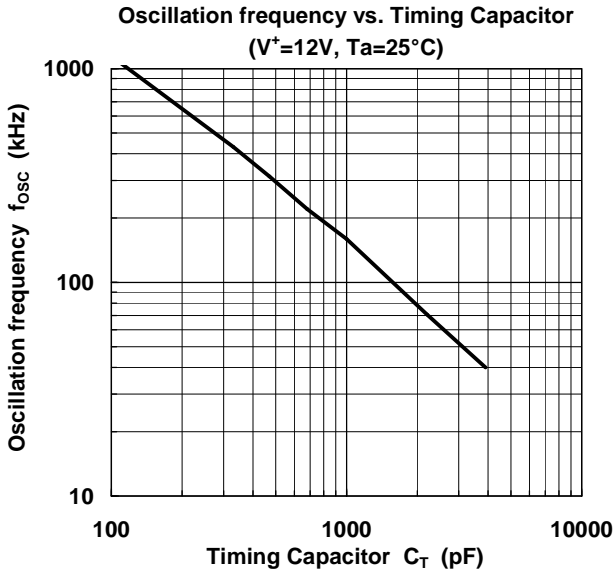

■ TYPICAL CHARACTERISTICS

Oscillation Frequency vs Temperature
($V^+=12V$, $C_T=470pF$)

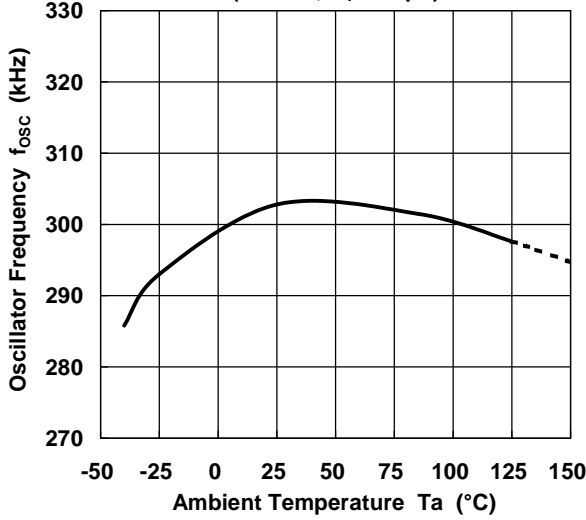

Reference Voltage vs. Temperature
($V^+=12V$)

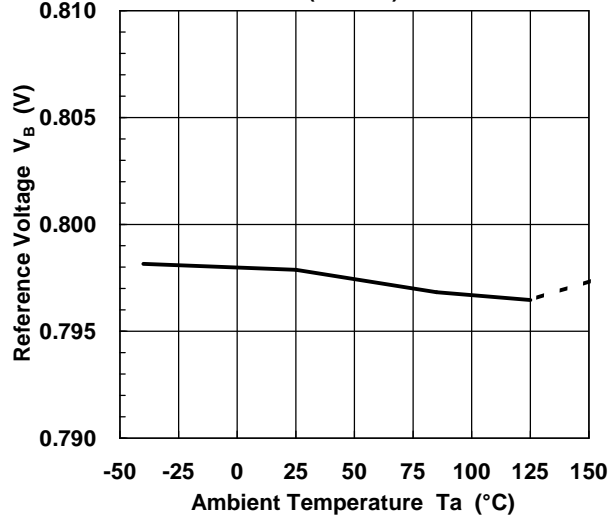

Current Limit Detection Voltage vs. Temperature
($V^+=12V$)

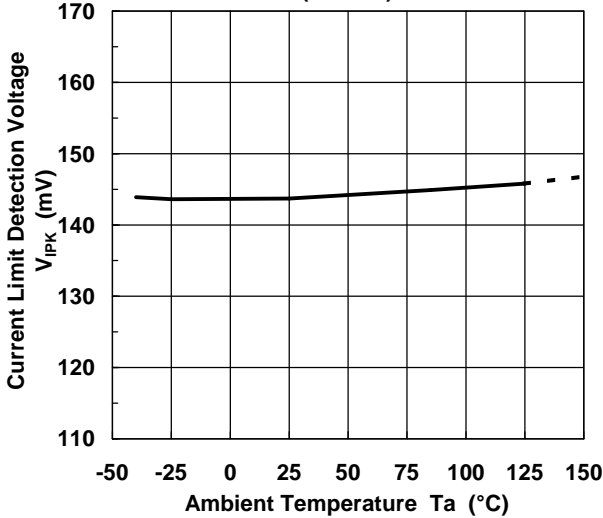

OUT pin Limiting Voltage vs. Temperature
($V^+=12V$)

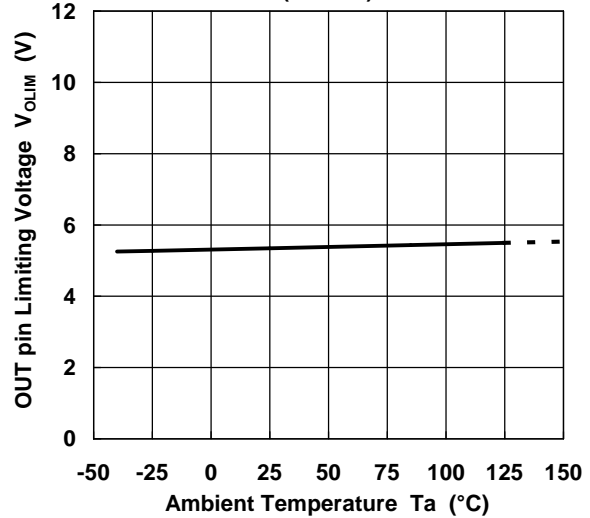

Output High Level ON Resistance vs. Temperature
($I_o=-50mA$)

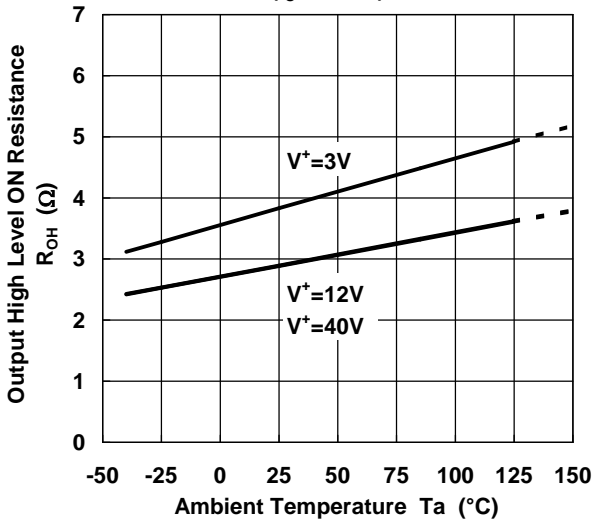

Output Low Level ON Resistance vs. Temperature
($I_o=+50mA$)

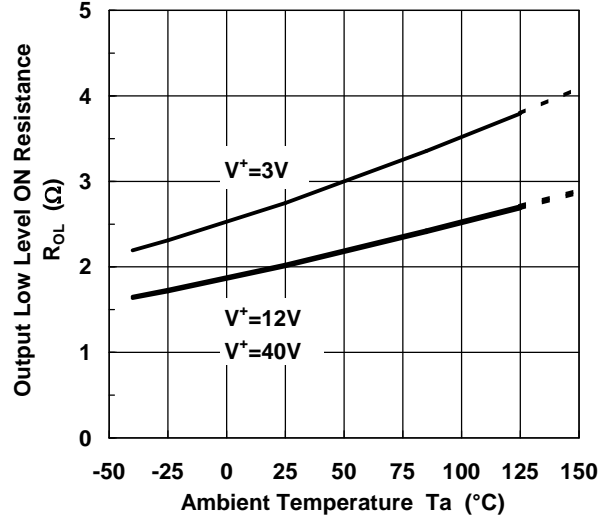

■ TYPICAL CHARACTERISTICS

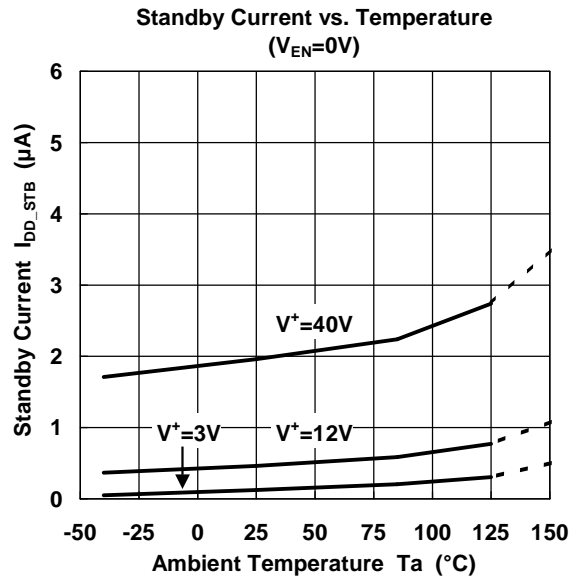
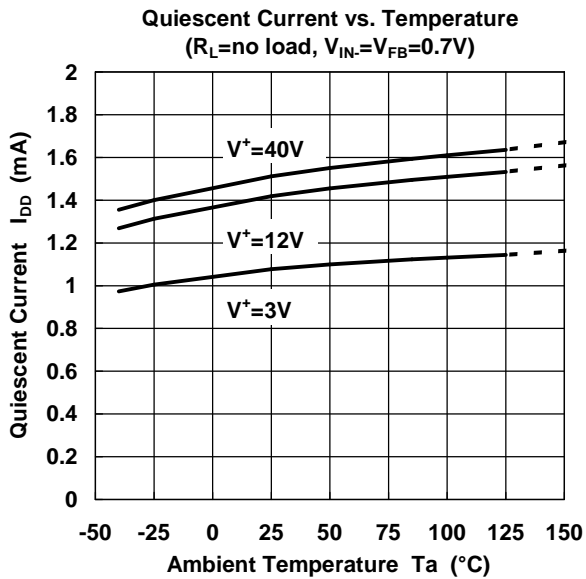
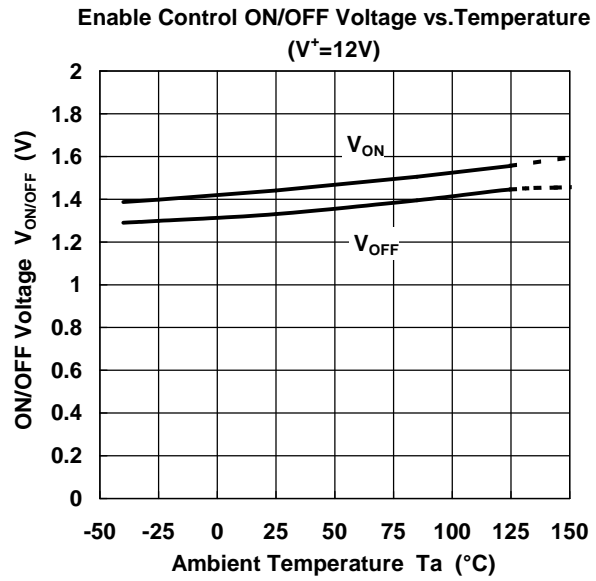
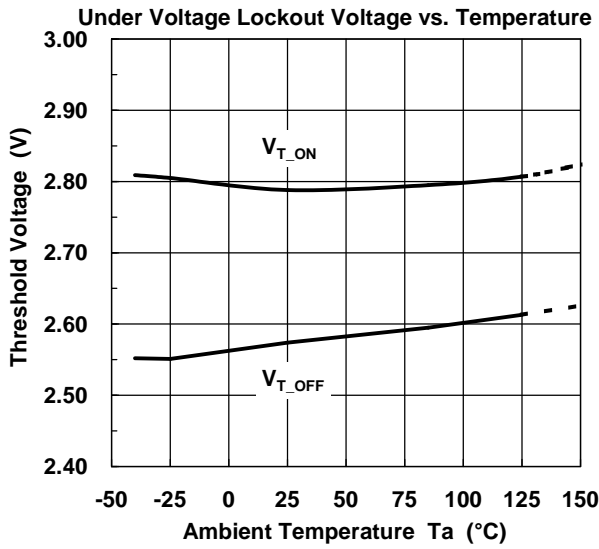

Technical Information

■ PIN DESCRIPTIONS

PIN NO.	NAME	FUNCTION
1	V ⁺	Power supply pin
2	EN	Enable control pin The ON/OFF pin internally pulls down with 500kΩ. Normal operation at the time of high level. Standby mode at the time of low level or OPEN.
3	IN-	Output voltage detecting pin Connects output voltage through the resistor divider tap to this pin in order to voltage of the IN- pin become 0.8V.
4	FB	Feedback setting pin The feedback resistor and capacitor are connected between the FB pin and the IN-pin.
5	CT	Oscillating frequency setting pin by Timing Capacitor Oscillating frequency should set between 40kHz and 1MHz.
6	GND	Ground pin
7	SI	Current sensing pin When difference voltage between the SI pin and the GND pin exceeds 140mV (typ.), over current protection operates.
8	OUT	Output pin for Power MOSFET driving The OUT pin voltage is clamped with 5.3V (typ.) at the time of high level, in order to protect a gate of Nch MOSFET.

Technical Information

■ Description of Block Features

Error Amplifier Section (ER-AMP)

0.8V±1% precise reference voltage is connected to the non-inverted input of this section.

To set the output voltage, connects converter's output to inverted input of this section (IN- pin). If requires output voltage over 0.8V, inserts resistor divider.

This AMP section has high gain and external feedback pin (FB pin). It is easy to insert a feedback resistor and a capacitor between the FB pin and the IN- pin, making possible to set optimum loop compensation for each type of application.

Oscillation Circuit Section (OSC)

Oscillation frequency can be set by inserting capacitor between the CT pin and GND. Referring to the sample characteristics in "Timing Capacitor and Oscillation Frequency", set oscillation frequency between 40kHz and 1MHz.

The triangular wave of the oscillating circuit is generated in the IC, having amplitude between 0.4V and 1.0V at $C_T = 470\text{pF}$ (ref.).

If voltage of the IN- pin becomes less than 0.4V, the oscillation frequency decreases to one third (33%) and the energy consumption is suppressed.

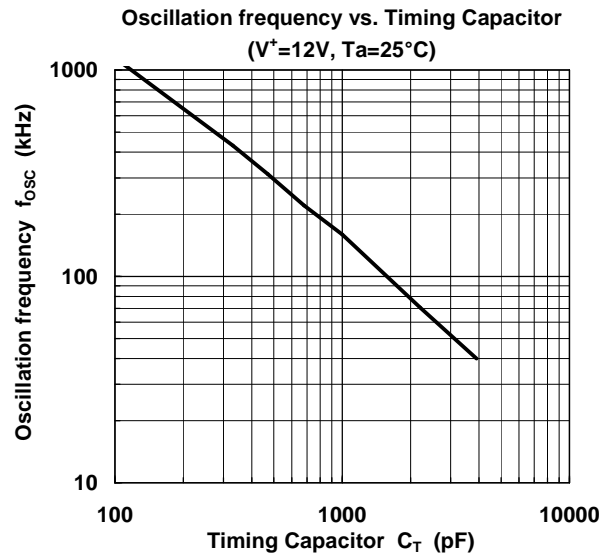

PWM Comparator Section (PWM)

This section controls the switching duty ratio.

PWM comparator receives the signal of the error amplifier and the triangular wave, and controls the duty ratio between 0% and 90%. The timing chart is shown in Fig.1.

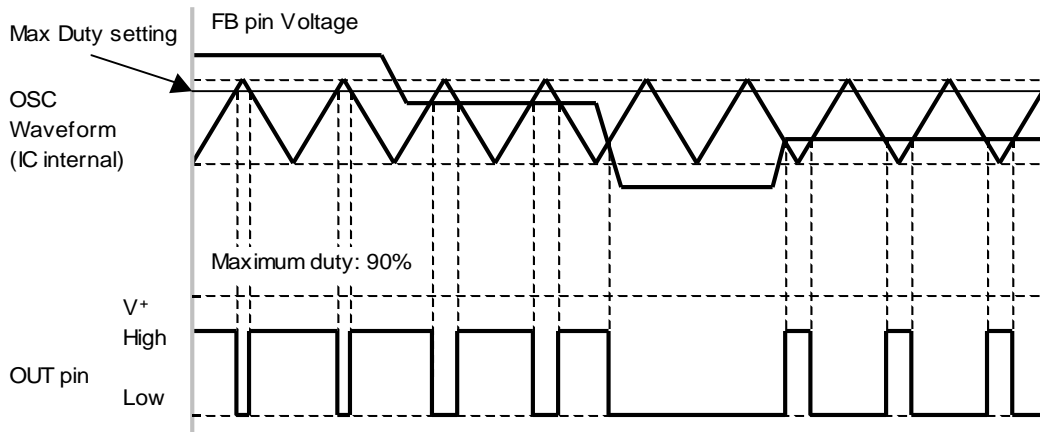

Fig.1. Timing Chart PWM Comparator and OUT pin

Technical Information

■ Description of Block Features (Continued)

Driver Section (Driver)

The output driver circuit is configured a totem pole type, it can efficiently drive a Nch MOSFET switching device. When the output is high level, the OUT pin voltage is clamped with 5.3V (typ.) by the internal regulator to protect gate of Nch MOSFET. (Ref. Fig.2. OUT pin)

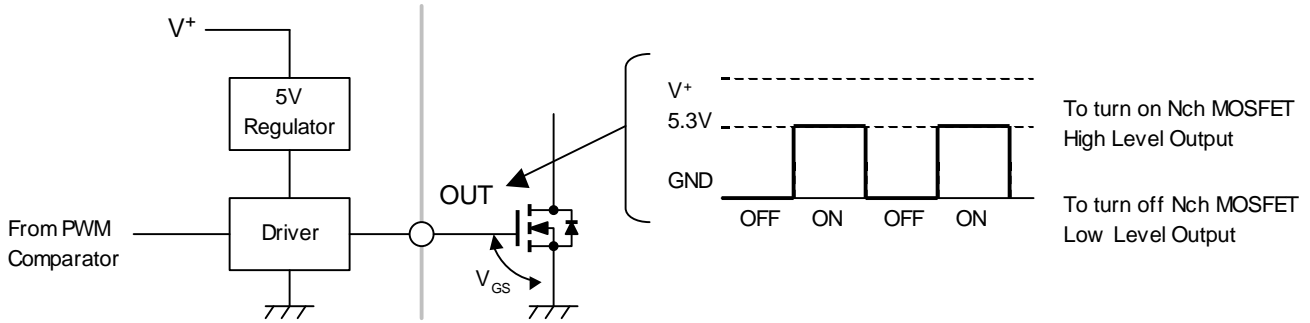

Fig.2. Driver Circuit and the OUT pin Voltage

When supply voltage is decreasing, gate drive voltage output from the OUT pin is also decreasing. Although the OUT pin voltage is kept gate drive voltage by bypassing the internal regulator around supply voltage 5V.

Fig.3. shows the example of the OUT pin voltage vs. supply voltage characteristic

The optimum drive ability of MOSFET depends on the oscillation frequency and the gate capacitance of MOSFET.

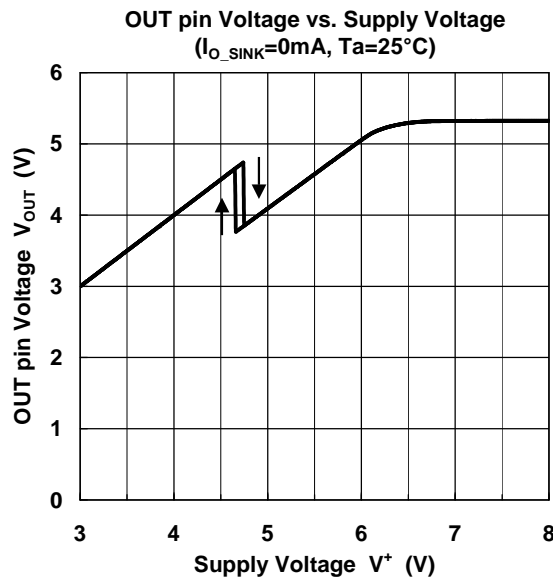

Fig.3. OUT pin Voltage vs. Supply Voltage Characteristic

Technical Information

■ Description of Block Features (Continued)

Power Supply, GND pin (V^+ , GND)

In line with MOSFET drive, current flows into the IC according to frequency. If the power supply impedance provided to the power supply circuit is high, it will not be possible to take advantage of IC performance due to input voltage fluctuation. Therefore insert a bypass capacitor close to the V^+ pin – the GND pin connection in order to lower high frequency impedance.

Undervoltage Lockout Function (UVLO)

The UVLO circuit operating is released above $V^+ = 2.8V$ (typ.) and IC operation starts. When power supply voltage is low, IC does not operate because the UVLO circuit operates. There is 250mV width hysteresis voltage at rise and decay of power supply voltage. Hysteresis prevents the malfunction at the time of UVLO operating and releasing.

Enable Function (Enable Control)

The NJW4140 stops the operating and becomes standby status when the EN pin becomes less than 0.9V. The EN pin internally pulls down with 500k Ω , therefore the NJW4140 becomes standby mode when the EN pin is OPEN. You should connect this pin to V^+ when you do not use Enable function.

Soft Start Function (Soft Start)

The output voltage of the converter gradually rises to a set value by the soft start function. The soft start time is 4ms (typ). It is defined with the time of the error amplifier reference voltage becoming from 0V to 0.75V. The soft start circuit operates after the release UVLO. The operating frequency is controlled with a low frequency, approximately 33% of the set value by the timing resistor, until voltage of the IN- pin becomes approximately 0.4V.

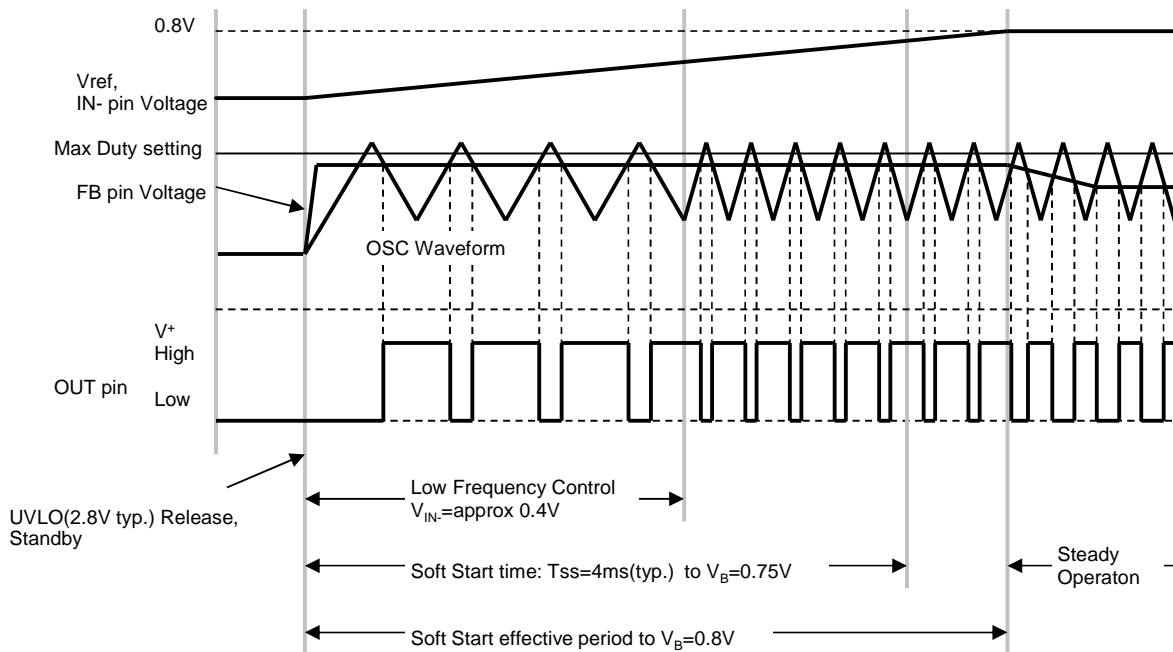

Fig.4. Startup Timing Chart

Technical Information

■ Description of Block Features (Continued)

Over Current Protection Circuit

At when the potential difference between the V^+ pin and the SI pin becomes 140mV or more, the over current protection circuit is stopped the switch output. The switching current is detected by inserted current sensing resistor (R_{SENSE}) between the SI pin and the GND pin. Fig.5. shows the timing chart of the over current protection detection.

The switching output holds low level until next pulse output at OCP operating. The NJW4140 output returns automatically along with release from the over current condition because the OCP is pulse-by-pulse type.

If voltage of the IN- pin becomes less than 0.4V, the oscillation frequency decreases to one third (33%) and the energy consumption is suppressed.

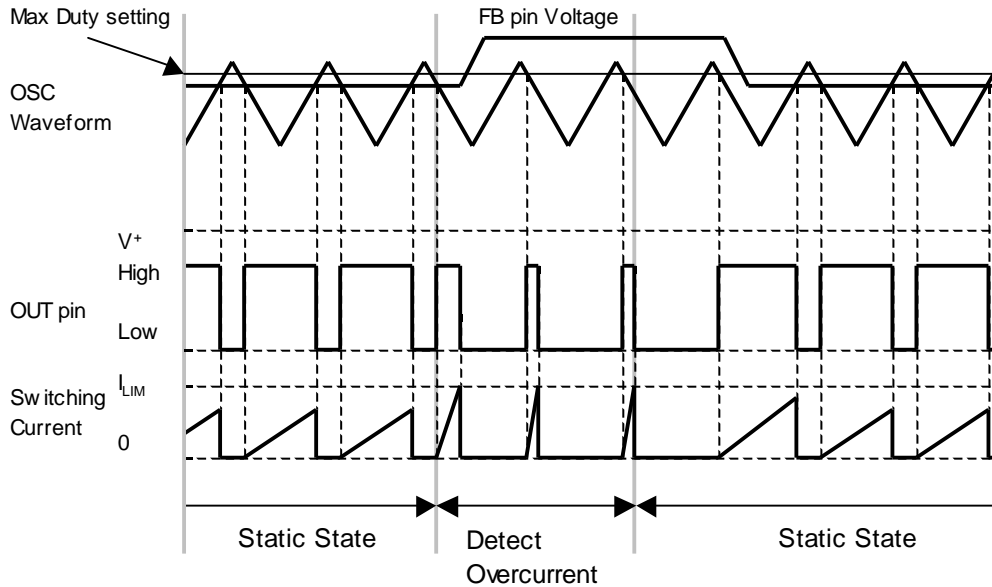

Fig.5. Timing Chart at Over Current Detection

The current waveform contains high frequency superimposed noises due to the parasitic elements of MOSFET, the inductor and the others. Depending on the application, inserting RC low-pass filter between current sensing resistor (R_{SENSE}) and the SI pin to prevent the malfunction due to such noise. The time constant of RC low-pass filter should be equivalent to the spike width ($T \leq R \times C$) as a rough guide (Fig. 6.).

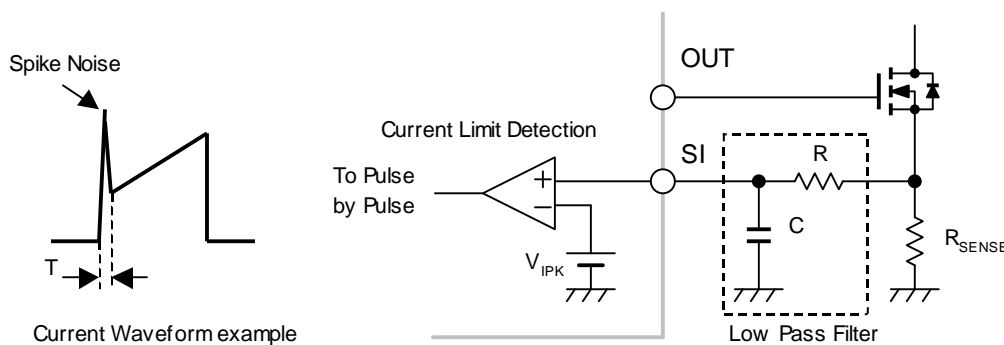

Fig.6. Current Waveform and Filter Circuit

Technical Information

■ Application Information

Inductors

Large currents flow into inductor, therefore you must provide current capacity that does not saturate.

Reducing L, the size of the inductor can be smaller. However, peak current increases and adversely affecting efficiency.

On the other hand, increasing L, peak current can be reduced at switching time. Therefore conversion efficiency improves, and output ripple voltage reduces. Above a certain level, increasing inductance windings increases loss (copper loss) due to the resistor element.

Ideally, the value of L is set so that inductance current is in continuous conduction mode. However, as the load current decreases, the current waveform changes from (1) CCM: Continuous Conduction Mode → (2) Critical Mode → (3) DCM: Discontinuous Conduction Mode (Fig. 7.).

In discontinuous mode, peak current increases with respect to output current, and conversion efficiency tend to decrease. Depending on the situation, increase L to widen the load current area to maintain continuous mode.

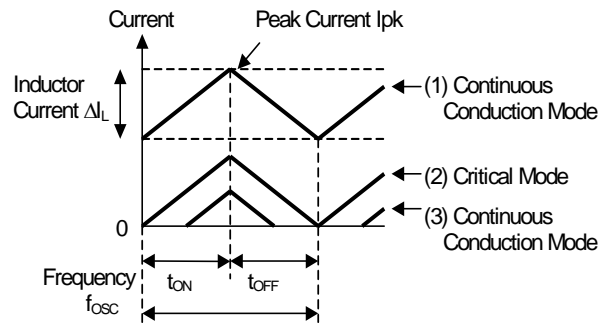

Fig.7. Inductor Current State Transition

Catch Diode

When the switch element is in OFF cycle, power stored in the inductor flows via the catch diode to the output capacitor. Therefore during each cycle current flows to the diode in response to load current. Because diode's forward saturation voltage and current accumulation cause power loss, a Schottky Barrier Diode (SBD), which has a low forward saturation voltage, is ideal.

An SBD also has a short reverse recovery time. If the reverse recovery time is long, through current flows when the switching transistor transitions from OFF cycle to ON cycle. This current may lower efficiency and affect such factors as noise generation.

When the switch element is in ON cycle, a reverse voltage flows to SBD. Therefore you should select a SBD that has reverse voltage rating greater than maximum output voltage. The power loss, which stored in output capacitor, will be increase due to increasing reverse current through SBD at high temperature. Therefore, there is cases preferring reverse current characteristics to forward current characteristic in order to improve efficiency.

Switching Element

You should use a switching element (Nch MOSFET) that is specified for use as a switch. And select sufficiently low R_{ON} MOSFET at less than $V_{GS} = 5V$ because the NJW4140 OUT pin voltage is clamped 5.3 (typ.).

However, when the supply voltage of the NJW4140 is low, the OUT pin voltage becomes low. You should select a suitable MOSFET according to the supply voltage specification. (Ref. Driver section)

Large gate capacitance is a source of decreased efficiency. That is charge and discharge from gate capacitance delays switching rise and fall time, generating switching loss.

The spike noise might occur at the time of charge/discharge of gate by the parasitic inductance element. You should insert resistance between the OUT pin and the gate and limit the current for gate protection when gate capacitance is small.

However, it should be noted that the efficiency might decrease because the shape of waves may become duller when resistance is too large. The last fine-tuning should be done on the actual device and equipment.

Technical Information

■ Application Information (Continued)

Input Capacitor

Transient current flows into the input section of a switching regulator responsive to frequency. If the power supply impedance provided to the power supply circuit is large, it will not be possible to take advantage of NJW4140 performance due to input voltage fluctuation. Therefore insert an input capacitor as close to the MOSFET as possible.

Output Capacitor

An output capacitor stores power from the inductor, and stabilizes voltage provided to the output.

When selecting an output capacitor, you must consider Equivalent Series Resistance (ESR) characteristics, ripple current, and breakdown voltage.

Also, the ambient temperature affects capacitors, decreasing capacitance and increasing ESR (at low temperature), and decreasing lifetime (at high temperature). Concerning capacitor rating, it is advisable to allow sufficient margin.

Output capacitor ESR characteristics have a major influence on output ripple noise. A capacitor with low ESR can further reduce ripple voltage. Be sure to note the following points; when ceramic capacitor is used, the capacitance value decreases with DC voltage applied to the capacitor.

Technical Information

■ Application Information (Continued)

Board Layout

In the switching regulator application, because the current flow corresponds to the oscillation frequency, the substrate (PCB) layout becomes an important.

You should attempt the transition voltage decrease by making a current loop area minimize as much as possible. Therefore, you should make a current flowing line thick and short as much as possible. Fig.8. shows a current loop at step-down converter.

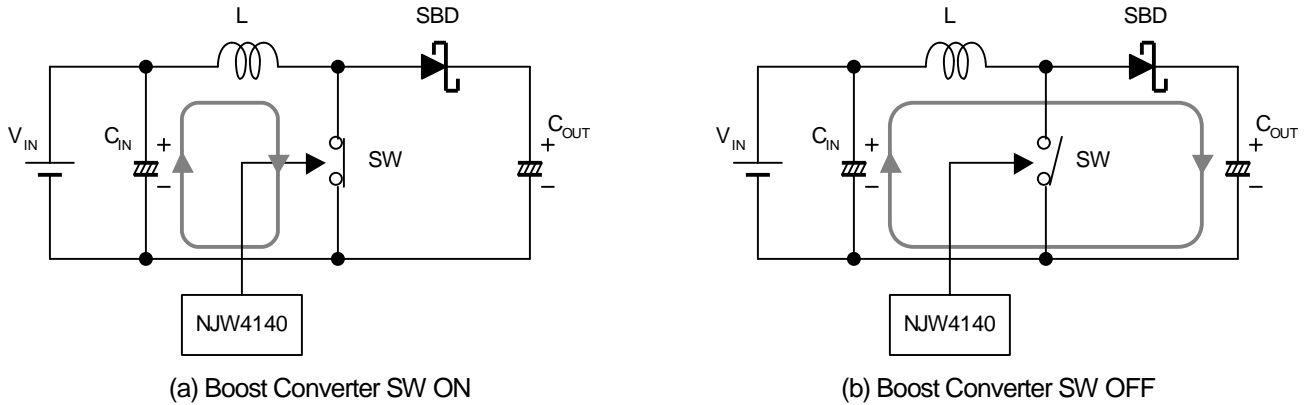

Fig.8. Current Loop at Boost Converter

Concerning the GND line, it is preferred to separate the power system and the signal system, and use single ground point. The voltage sensing feedback line should be as far away as possible from the inductance. Because this line has high impedance, it is laid out to avoid the influence noise caused by flux leaked from the inductance.

Fig.9. shows example of wiring at boost converter. Fig.10. shows the PCB layout example.

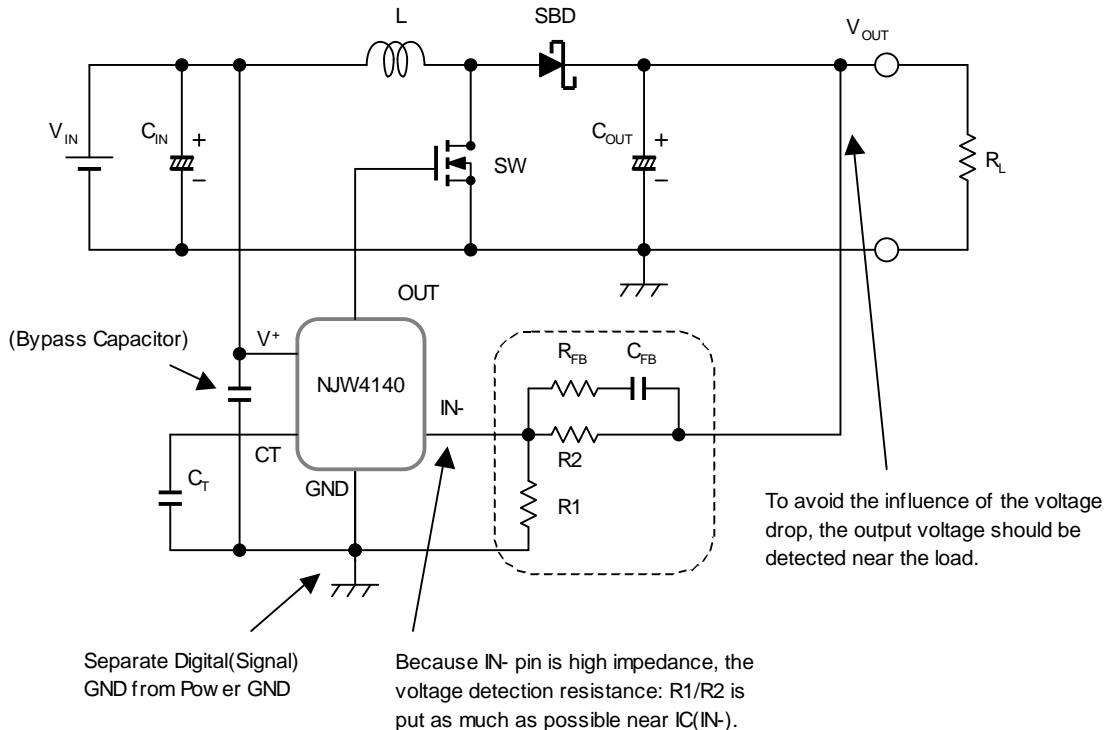

Fig.9. Board Layout at Boost Converter

Technical Information

■ Calculation of Package Power

You should consider derating power consumption under using high ambient temperature. Moreover, you should consider the power consumption that occurs in order to drive the switching element.

Supply Voltage	: V^+
Quiescent Current	: I_{DD}
Oscillation Frequency	: f_{OSC}
ON time	: t_{on}
Gate charge amount	: Q_g

The gate of MOSFET has the character of high impedance. The power consumption increases by quickening the switching frequency due to charge and discharge the gate capacitance. Power consumption: P_D is calculated as follows.

$$P_D = (V^+ \times I_{DD}) + (V^+ \times Q_g \times f_{OSC}) \text{ [W]}$$

You should consider temperature derating to the calculated power consumption: P_D . You should design power consumption in rated range referring to the power dissipation vs. ambient temperature characteristics (Fig.11.).

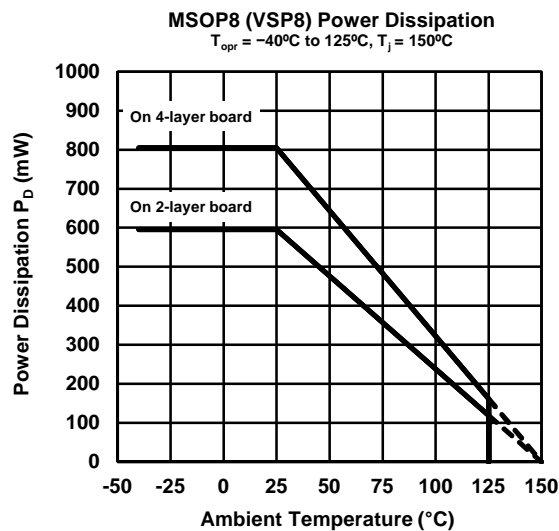

2-Layer: Mounted on glass epoxy board (76.2 mm × 114.3 mm × 1.6 mm: based on EIA/JEDEC standard, 2-layer FR-4).

4-Layer: Mounted on glass epoxy board (76.2 mm × 114.3 mm × 1.6 mm: based on EIA/JEDEC standard, 4-layer FR-4),
 internal Cu area: 74.2 mm × 74.2 mm.

Fig.11. Power Dissipation vs. Ambient Temperature Characteristics

Technical Information

Application Design Examples

Step-Up Application Circuit

IC : NJW4140R
 Input Voltage : $V_{IN} = 9V \text{ to } 15V$
 Output Voltage : $V_{OUT} = 20V$
 Output Current : $I_{OUT} = 1.5A \text{ (@ } V_{IN} = 12V)$
 Oscillation frequency : $f_{OSC} = 300kHz$

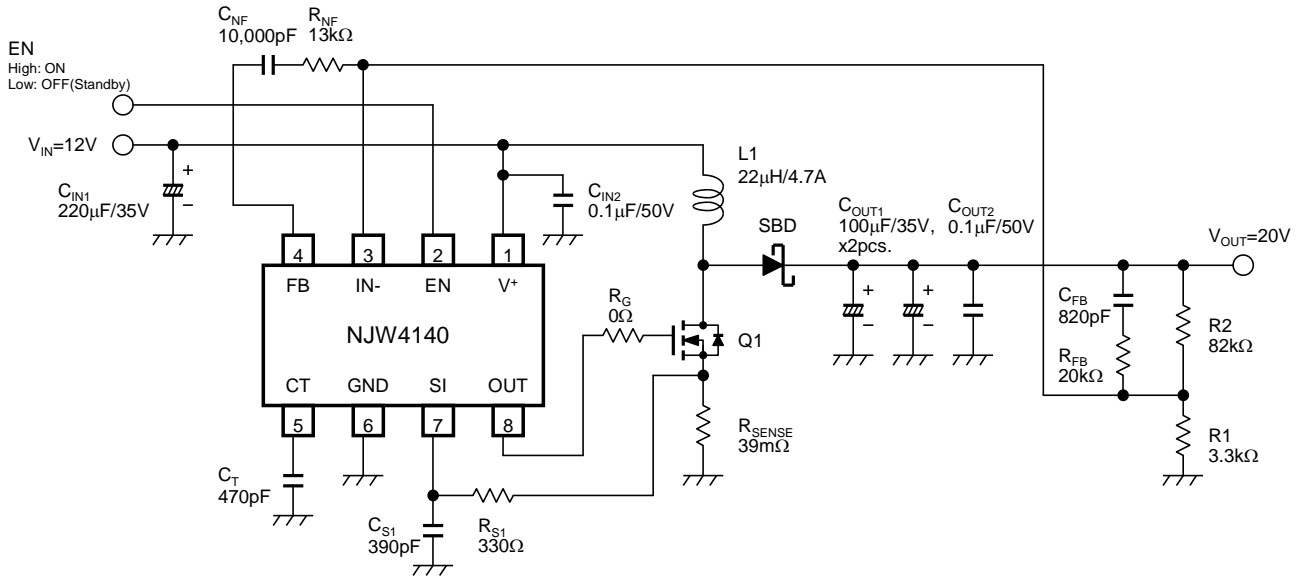

Reference	Qty.	Part Number	Description	Manufacturer
IC	1	NJW4140R	MOSFET Drive Switching Regulator IC for Boost/Fly-back Converter IC	NJR
Q1	1	TPCA8052-H	Nch MOSFET 40V, 20A	Toshiba
L1	1	CDRH127LDNP-220	Inductor 22µH, 4.7A	Sumida
SBD	1	DE5SC4M	Schottky Diode 40V, 5A	Shindengen
C _{IN1}	1	EEEFP1V221AP	Aluminum Electrolytic Capacitor 220µF, 35V	Panasonic
C _{IN2}	1	0.1µF	Ceramic Capacitor 1608 0.1µF, 50V, B	Std.
C _{OUT1}	2	EEEFP1V101AP	Aluminum Electrolytic Capacitor 100µF, 35V	Panasonic
C _{OUT2}	1	0.1µF	Ceramic Capacitor 1608 0.1µF, 50V, B	Std.
C _T	1	470pF	Ceramic Capacitor 1608 470pF, 50V, CH	Std.
C _{NF}	1	10,000pF	Ceramic Capacitor 1608 10,000pF, 50V, B	Std.
C _{FB}	1	820pF	Ceramic Capacitor 1608 820pF, 50V, B	Std.
C _{S1}	1	390pF	Ceramic Capacitor 1608 390pF, 50V, CH	Std.
R1	1	3.3kΩ	Resistor 1608 3.3kΩ, ±1%, 0.1W	Std.
R2	1	82kΩ	Resistor 1608 82kΩ, ±1%, 0.1W	Std.
R _{NF}	1	13kΩ	Resistor 1608 13kΩ, ±1%, 0.1W	Std.
R _{FB}	1	20kΩ	Resistor 1608 20kΩ, ±1%, 0.1W	Std.
R _{SENSE}	1	UR73D3ATTE39L0F	Resistor 2512 39mΩ, ±1%, 1W	KOA
R _G	1	0Ω (Short)	Resistor 1608 0Ω, 0.1W	Std.
R _{S1}	1	330Ω	Resistor 1608 330Ω, ±1%, 0.1W	Std.

Technical Information

■ Application Design Examples (Continued)

Setting Oscillation Frequency

From the Oscillation frequency vs. Timing Capacitor Characteristic, reads $C_T = 470$ [pF], $t = 3.33$ [μ s] at $f_{OSC} = 300$ kHz. Step-Up converter duty ratio is shown with the following equation.

$$\text{Duty} = \left(1 - \frac{V_{IN}}{V_{OUT}}\right) \times 100 = \left(1 - \frac{12}{20}\right) \times 100 = 40 \text{ [%]}$$

Therefore, $t_{ON} = 1.33$ [μ s], $t_{OFF} = 2.0$ [μ s]

Selecting Inductance

The inductor's average current equals input current (I_{IN}). Estimated efficiency (η) is 93% and calculates input current as follows.

$$I_{IN} = \frac{V_{OUT} \times I_{OUT}}{\eta \times V_{IN}} = \frac{20 \times 1.5}{0.93 \times 12} = 2.69 \text{ [A]}$$

ΔI_L is Inductance ripple current. When ΔI_L is 27% of input current:

$$\Delta I_L = 0.27 \times I_{IN} = 0.27 \times 2.69 = 0.73 \text{ [A]}$$

This obtains inductance L.

$$L = \frac{V_{IN}}{\Delta I_L} \times t_{ON} = \frac{12}{0.73} \times 1.33\mu = 22 \text{ [\mu H]}$$

Inductance L is a theoretical value. The optimum value varies according such factors as application specifications and components. Fine-tuning should be done on the actual device.

This obtains the peak current I_{pk} at switching time.

$$I_{pk} = I_{IN} + \frac{\Delta I_L}{2} = 2.69 + \frac{0.73}{2} = 3.06 \text{ [A]}$$

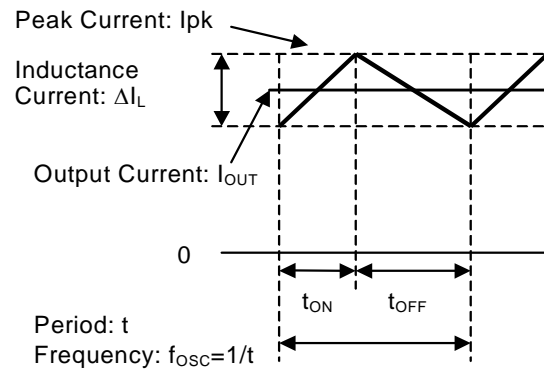

Fig.12. Inductor Current Waveform

The current that flows into the inductance provides sufficient margin for peak current at switching time. In the application circuit, use $L = 22\mu$ H, 4.5A.

Setting Over Current Detection

In this application, current limitation value: I_{LIMIT} is set to $I_{pk} = 3.5$ A.

$$I_{LIMIT} = V_{IPK} / R_{SC} = 140\text{mV} / 39\text{m}\Omega = 3.59 \text{ [A]}$$

The limit value increases slightly according to response time from the overcurrent detection with the SI pin to the OUT pin stop.

$$I_{LIMIT_DELAY} = I_{LIMIT} + \frac{V_{IN}}{L} \times T_{DELAY} = 3.59 + \frac{12}{22\mu} \times 90\text{n} = 3.64 \text{ [A]}$$

Technical Information

■ Application Design Examples (Continued)

Selecting the Input Capacitor

The input capacitor corresponds to the input of the power supply. It is required to adequately reduce the impedance of the power supply. The input capacitor selection should be determined by the input ripple current and the maximum input voltage of the capacitor rather than its capacitance value.

The effective input current can be expressed by the following formula.

$$I_{\text{RMS_CIN}} = \frac{\Delta I_L}{2\sqrt{3}} = \frac{0.73}{2\sqrt{3}} = 0.21 \text{ [Arms]}$$

When selecting the input capacitor, carry out an evaluation based on the application, and use a capacitor that has adequate margin.

Selecting the Output Capacitor

The output capacitor is an important component that determines output ripple noise. Equivalent Series Resistance (ESR), ripple current, and capacitor breakdown voltage are important in determining the output capacitor.

The output ripple noise can be expressed by the following formula.

$$V_{\text{ripple}} = \text{ESR} \times \left(I_L + \frac{\Delta I_L}{2} \right) = 40\text{m} \times \left(2.69 + \frac{0.73}{2} \right) = 122 \text{ [mV]}$$

When selecting output capacitance, select a capacitor that allows for sufficient ripple current.

The effective ripple current that flows in a capacitor ($I_{\text{RMS_COUT}}$) is obtained by the following equation.

$$I_{\text{RMS_COUT}} = I_{\text{OUT}} \times \sqrt{\frac{V_{\text{OUT}} - V_{\text{IN}}}{V_{\text{IN}}}} = 1.5 \times \sqrt{\frac{20 - 12}{12}} = 1.22 \text{ [Arms]}$$

Consider sufficient margin, and use a capacitor that fulfills the above spec.

In the application circuit, Aluminum Electrolytic Capacitor $C_{\text{OUT}} = 100\mu\text{F} / 35\text{V}$ are used by 2 parallel.

Setting Output Voltage

The output voltage V_{OUT} is determined by the relative resistances of R1, R2. The current that flows in R1, R2 must be a value that can ignore the bias current that flows in Error AMP.

$$V_{\text{OUT}} = \left(\frac{R2}{R1} + 1 \right) \times V_B = \left(\frac{82\text{k}}{3.3\text{k}} + 1 \right) \times 0.8 = 20.7 \text{ [V]}$$

It is easy to make a feedback loop, because the error amplifier output connects to FB pin. DC gain affects voltage sensing of the error amplifier. If AC gain increases, it affects stability of regulator due to AC gain which contains switching noise, ripple noise and the others.

Recommended way of feedback is high DC gain and low AC gain.

In this application, a feedback resistor $R_{\text{NF}} = 13\text{k}\Omega$ and capacitor $C_{\text{NF}} = 10,000\text{pF}$ are connected in serial.

However, if the AC gain is lowered too much, it happens slower transient response against fast load changes. The optimum value varies according such factors as application specifications and components. Fine-tuning should be done on the actual device.

■ Application Characteristics

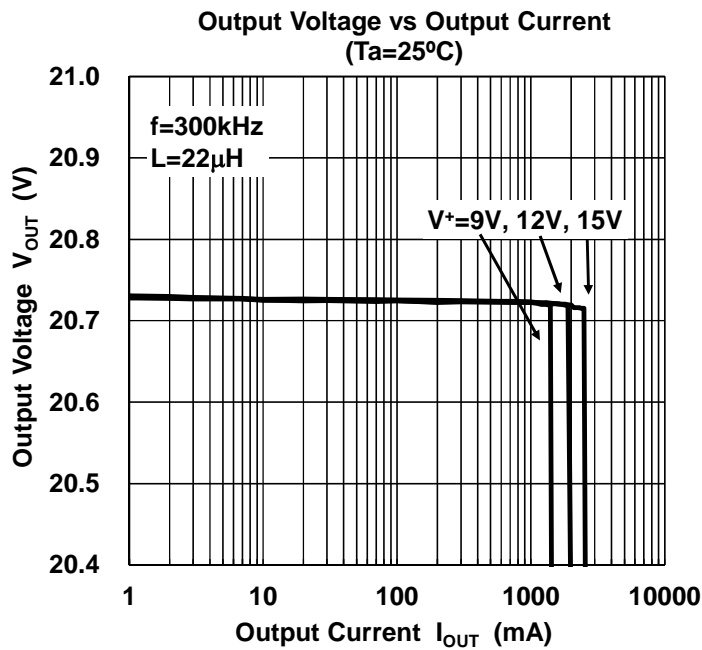
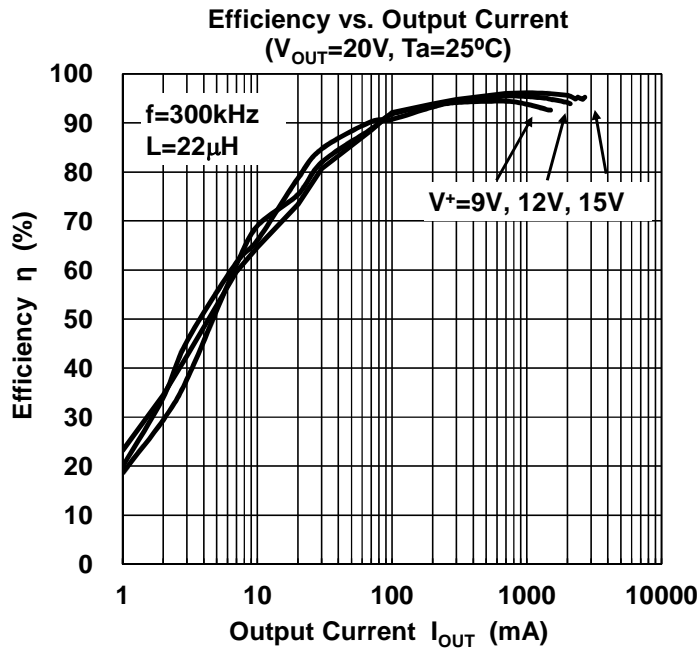

■ PACKAGE DIMENSIONS

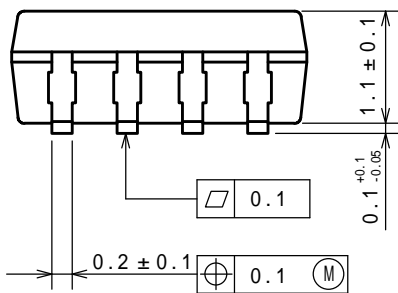
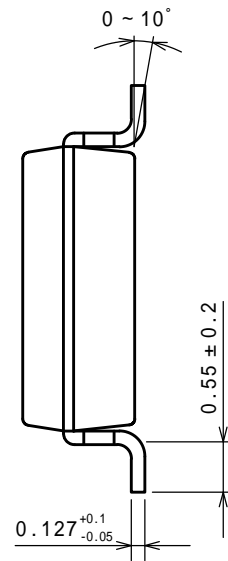
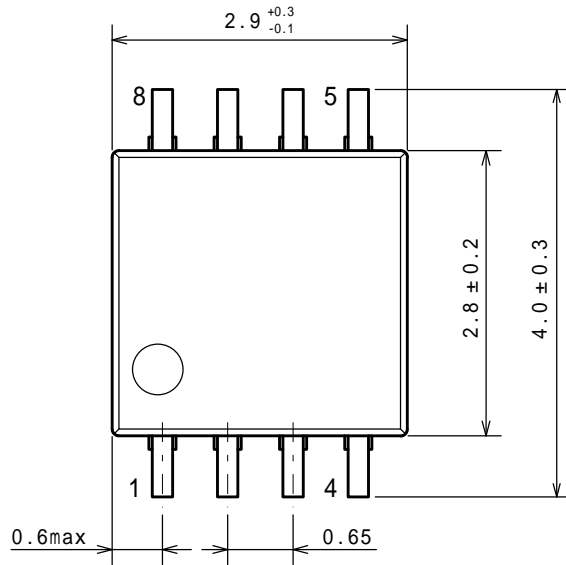

■ EXAMPLE OF SOLDER PADS DIMENSIONS

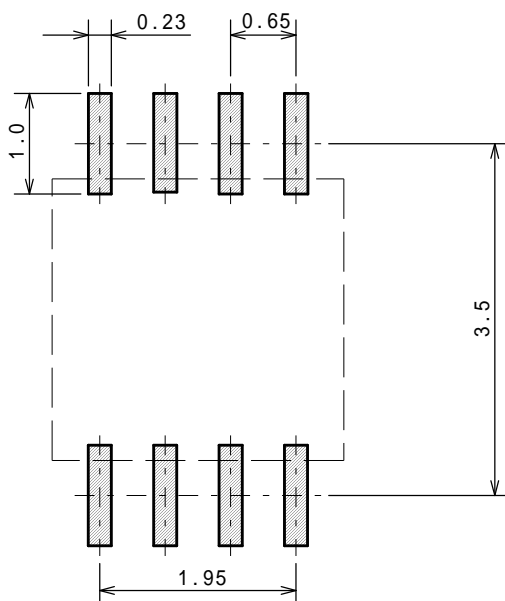

Unit: mm

PACKING SPEC TAPING DIMENSIONS

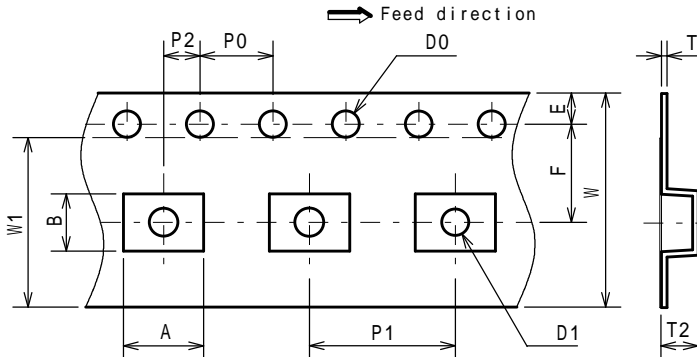

SYMBOL	DIMENSION	REMARKS
A	4.4	BOTTOM DIMENSION
B	3.2	BOTTOM DIMENSION
D0	1.5 ^{+0.1} ₀	
D1	1.5 ^{+0.1} ₀	
E	1.75 ± 0.1	
F	5.5 ± 0.05	
P0	4.0 ± 0.1	
P1	8.0 ± 0.1	
P2	2.0 ± 0.05	
T	0.30 ± 0.05	
T2	2.0 (MAX.)	
W	12.0 ± 0.3	
W1	9.5	THICKNESS 0.1max

REEL DIMENSIONS

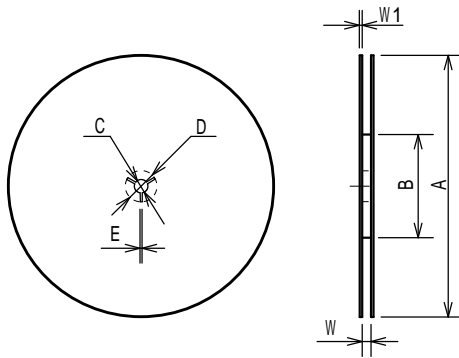

SYMBOL	DIMENSION
A	254 ± 2
B	100 ± 1
C	13 ± 0.2
D	21 ± 0.8
E	2 ± 0.5
W	13.5 ± 0.5
W1	2.0 ± 0.2

TAPING STATE

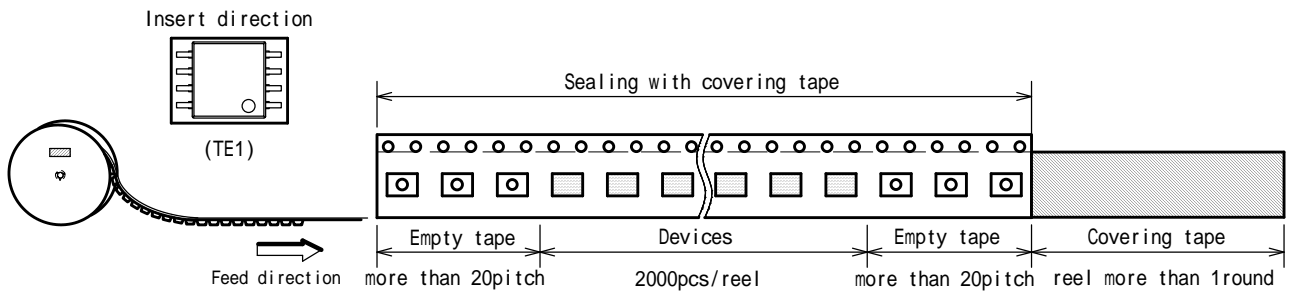

PACKING STATE

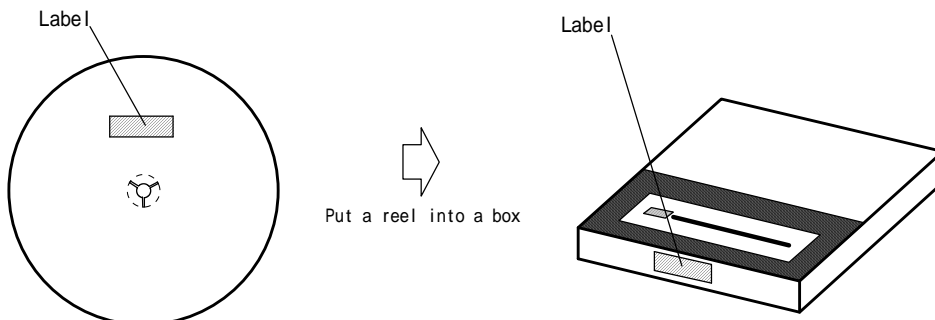

■ RECOMMENDED MOUNTING METHOD

INFRARED REFLOW SOLDERING PROFILE

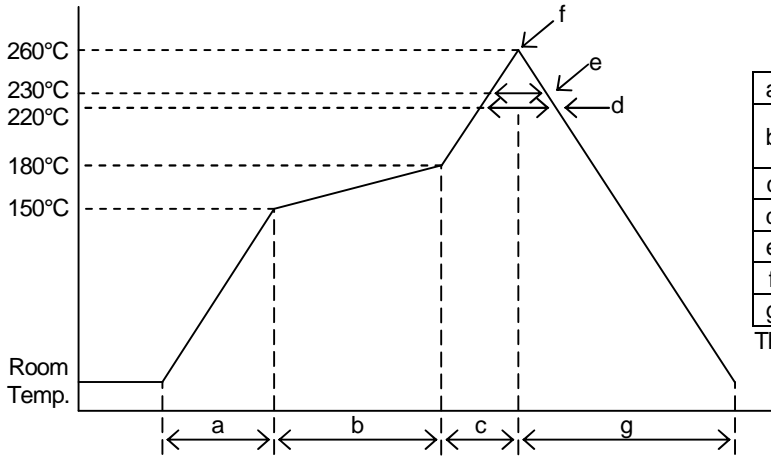

a	Temperature ramping rate	1 to 4°C/s
b	Pre-heating temperature	150 to 180°C
	Pre-heating time	60 to 120s
c	Temperature ramp rate	1 to 4°C/s
d	220°C or higher time	shorter than 60s
e	230°C or higher time	shorter than 40s
f	Peak temperature	lower than 260°C
g	Temperature ramping rate	1 to 6°C/s

The temperature indicates at the surface of mold package.

■ REVISION HISTORY

DATE	REVISION	CHANGES
February 19, 2020	Ver.1.0	Initial Release
June 24, 2020	Ver.1.1	Changed datasheet format

[CAUTION]

1. NJR strives to produce reliable and high quality semiconductors. NJR's semiconductors are intended for specific applications and require proper maintenance and handling. To enhance the performance and service of NJR's semiconductors, the devices, machinery or equipment into which they are integrated should undergo preventative maintenance and inspection at regularly scheduled intervals. Failure to properly maintain equipment and machinery incorporating these products can result in catastrophic system failures.
2. The specifications on this datasheet are only given for information without any guarantee as regards either mistakes or omissions. The application circuits in this datasheet are described only to show representative usages of the product and not intended for the guarantee or permission of any right including the industrial property rights.
All other trademarks mentioned herein are the property of their respective companies.
3. To ensure the highest levels of reliability, NJR products must always be properly handled.
The introduction of external contaminants (e.g. dust, oil or cosmetics) can result in failures of semiconductor products.
4. NJR offers a variety of semiconductor products intended for particular applications. It is important that you select the proper component for your intended application. You may contact NJR's Sale's Office if you are uncertain about the products listed in this datasheet.
5. Special care is required in designing devices, machinery or equipment which demand high levels of reliability. This is particularly important when designing critical components or systems whose failure can foreseeably result in situations that could adversely affect health or safety. In designing such critical devices, equipment or machinery, careful consideration should be given to amongst other things, their safety design, fail-safe design, back-up and redundancy systems, and diffusion design.
6. The products listed in this datasheet may not be appropriate for use in certain equipment where reliability is critical or where the products may be subjected to extreme conditions. You should consult our sales office before using the products in any of the following types of equipment.
 - Aerospace Equipment
 - Equipment Used in the Deep Sea
 - Power Generator Control Equipment (Nuclear, steam, hydraulic, etc.)
 - Life Maintenance Medical Equipment
 - Fire Alarms / Intruder Detectors
 - Vehicle Control Equipment (Airplane, railroad, ship, etc.)
 - Various Safety Devices
7. NJR's products have been designed and tested to function within controlled environmental conditions. Do not use products under conditions that deviate from methods or applications specified in this datasheet. Failure to employ the products in the proper applications can lead to deterioration, destruction or failure of the products. NJR shall not be responsible for any bodily injury, fires or accident, property damage or any consequential damages resulting from misuse or misapplication of the products. The products are sold without warranty of any kind, either express or implied, including but not limited to any implied warranty of merchantability or fitness for a particular purpose.
8. Warning for handling Gallium and Arsenic (GaAs) Products (Applying to GaAs MMIC, Photo Reflector). These products use Gallium (Ga) and Arsenic (As) which are specified as poisonous chemicals by law. For the prevention of a hazard, do not burn, destroy, or process chemically to make them as gas or power. When the product is disposed of, please follow the related regulation and do not mix this with general industrial waste or household waste.
9. The product specifications and descriptions listed in this datasheet are subject to change at any time, without notice.



X-ON Electronics

Largest Supplier of Electrical and Electronic Components

Click to view similar products for [Switching Voltage Regulators](#) category:

Click to view products by [Nisshinbo](#) manufacturer:

Other Similar products are found below :

[FAN53610AUC33X](#) [FAN53611AUC123X](#) [FAN48610BUC33X](#) [FAN48610BUC45X](#) [FAN48617UC50X](#) [R3](#) [430464BB](#) [KE177614](#)
[MAX809TTR](#) [NCV891234MW50R2G](#) [NCP81103MNTXG](#) [NCP81203PMNTXG](#) [NCP81208MNTXG](#) [NCP81109GMNTXG](#)
[SCY1751FCCT1G](#) [NCP81109JMNTXG](#) [AP3409ADNTR-G1](#) [NCP81241MNTXG](#) [LTM8064IY](#) [LT8315EFE#TRPBF](#) [NCV1077CSTBT3G](#)
[XCL207A123CR-G](#) [MPM54304GMN-0002](#) [MPM54304GMN-0003](#) [XDPE132G5CG000XUMA1](#) [MP8757GL-P](#) [MIC23356YFT-TR](#)
[LD8116CGL](#) [HG2269M/TR](#) [OB2269](#) [XD3526](#) [U6215A](#) [U6215B](#) [U6620S](#) [LTC3803ES6#TR](#) [LTC3803ES6#TRM](#) [LTC3412IFE](#) [LT1425IS](#)
[MAX25203BATJA/VY+](#) [MAX77874CEWM+](#) [XC9236D08CER-G](#) [ISL95338IRTZ](#) [MP3416GJ-P](#) [BD9S201NUX-CE2](#) [MP5461GC-Z](#)
[MPQ4415AGQB-Z](#) [MPQ4590GS-Z](#) [MCP1603-330IMC](#) [MCP1642B-18IMC](#) [MCP1642D-ADJIMC](#)