

300mA LDO REGULATOR

NO.EA-078-140822

OUTLINE

The R1130x Series are CMOS-based voltage regulator (VR) ICs. VR function has features of high ripple rejection, low dropout voltage, high output voltage accuracy, and ultra-low supply current. Each of these ICs consists of a voltage reference unit, an error amplifier, resistors for setting output voltage, and a current limit circuit. Each of the R1130xxxxA/B type includes also a chip enable circuit.

The output voltage of the R1130xxxxC type is adjustable with external resistors.

The output voltage of R1130xxxxA/B is fixed in the IC. Low supply current by the merit of CMOS process and built-in transistors with low ON-resistance make low dropout voltage. These regulators in the R1130x Series are remarkable improvement on the current regulators in terms of ripple rejection, input transient response, and load transient response. Maximum Output Current is large for its compact size.

Thus, the R1130x Series are suitable for power supply for CD-drives, DVD-drives, and so forth.

Since the packages for these ICs are the SOT-89-5 package or HSON-6 (**Discontinued**), high density mounting of the ICs on boards is possible.

FEATURES

- Supply Current Typ. 50 μ A
- Standby Current Typ. 0.1 μ A (VR) for A type
- Ripple Rejection Typ. 60dB (f=1kHz) (VR)
- Output Current Min. 300mA ($V_{IN}=V_{OUT}+1V$)
- Output Voltage Range 1.5V to 5.0V (0.1V steps)
Externally specified with the ADJUST pin
(Reference Voltage 1.8V : C Version)
(For other voltages, please refer to MARK INFORMATIONS.)
- Output Voltage Accuracy $\pm 2.0\%$ (VR) for A/B type,
 $\pm 2.0\%$ (Reference Voltage for adjustable VR) for C type
- Dropout Voltage Typ. 0.2V ($I_{OUT}=100mA$) (VR)
- Temperature-drift Coefficient of Output Voltage $\pm 100ppm/^{\circ}C$
- Absolute Maximum Voltage 9.0V
- Packages SOT-89-5, HSON-6 (**Discontinued**)
- Built-in Current Limit Circuit
- Internal Phase Compensation (small output capacitance such as 0.1 μ F Ceramic can be used with.)

APPLICATIONS

- Power source for CD-drives and DVD-drives, HDD.
- Local Power source for Notebook PC.

BLOCK DIAGRAMS

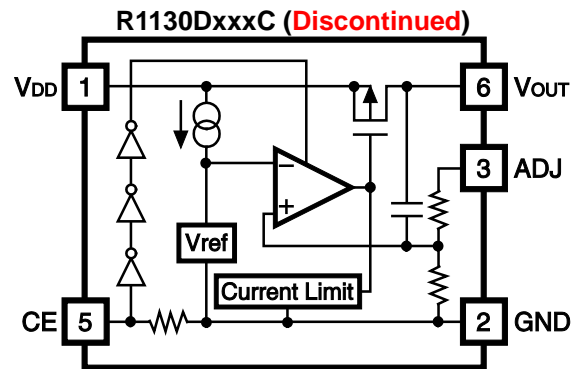
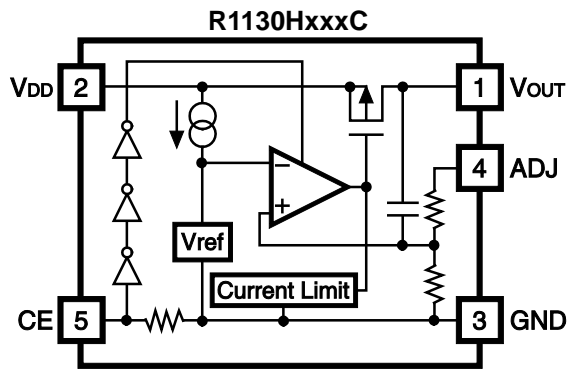
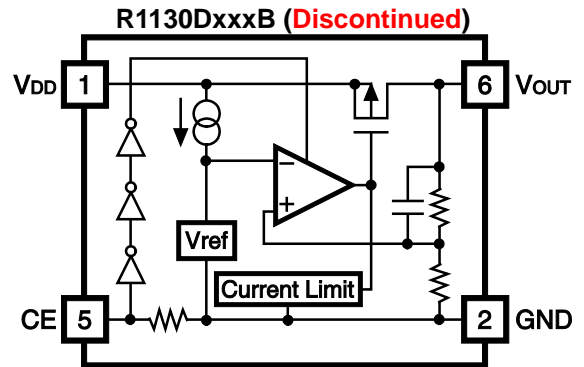
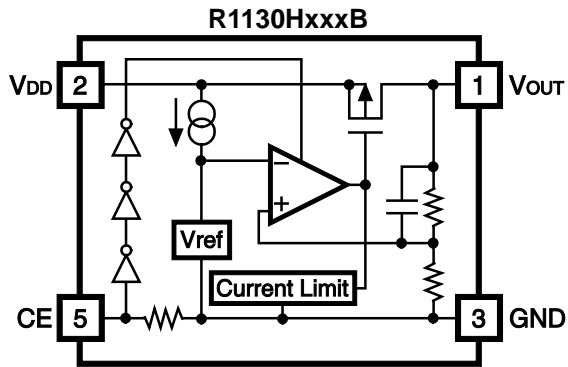
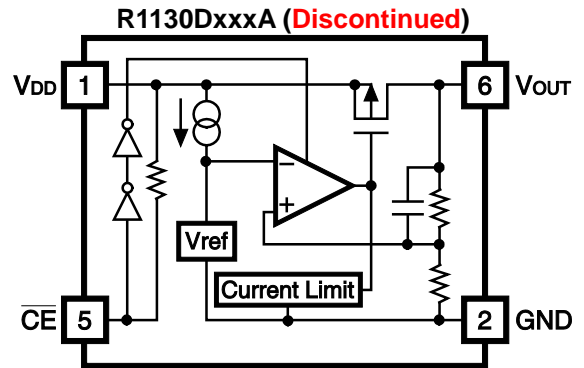
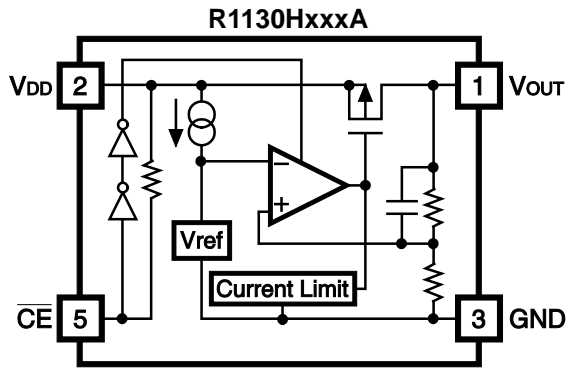

SELECTION GUIDE

The output voltage, CE pin polarity, package for the ICs can be selected at the user's request.

Product Name	Package	Quantity per Reel	Pb Free	Halogen Free
R1130Dxx1*-TR-FE	HSO6-6 (Discontinued)	3,000 pcs	Yes	Yes
R1130Hxx1*-T1-FE	SOT-89-5	1,000 pcs	Yes	Yes

xx: The output voltage can be designated in the range from 1.5V(15) to 5.0V(50) in 0.1V steps.
(C Version is fixed at 00.)
(For other voltages, please refer to MARK INFORMATIONS.)

* : CE pin polarity are options as follows.
(A) "L" active
(B) "H" active
(C) "H" active, with ADJUST pin.

PIN CONFIGURATION

• SOT-89-5

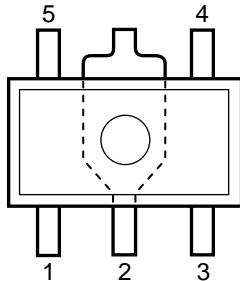

• HSON-6

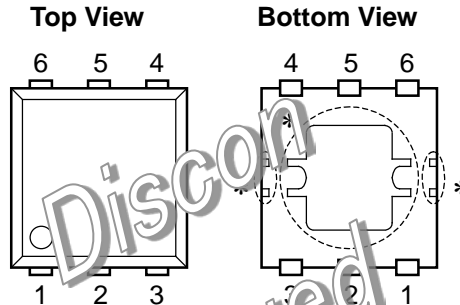

PIN DESCRIPTIONS

• SOT-89-5

Pin No.	Symbol	Description
1	V_{OUT}	Voltage Regulator Output Pin
2	V_{DD}	Input Pin
3	GND	Ground Pin
4	NC (A/B type)	No Connection
	ADJ (C type)	Adjustable Regulator feedback Input Pin (Connect to resistor voltage divider.)
5	\overline{CE} (A type) or CE (B/D type)	Chip Enable Pin

• HSON-6 (Discontinued)

Pin No.	Symbol	Description
1	V_{DD}	Input Pin
2	GND	Ground Pin
3	NC (A/B type)	No Connection
	ADJ (C type)	Adjustable Regulator feedback Input Pin (Connect to resistor voltage divider.)
4	NC	No Connection
5	\overline{CE} (A type) or CE (B/D type)	Chip Enable Pin
6	V_{OUT}	Voltage Regulator Output Pin

*) Tab and tab suspension leads are V_{DD} level. (They are connected to the reverse side of the IC.)
 The tab is better to be connected to the V_{DD} , but leaving it open is also acceptable.
 The tab suspension leads should be open and do not connect to other wires or land patterns.

ABSOLUTE MAXIMUM RATINGS

Symbol	Item	Rating	Unit
V_{IN}	Input Voltage	9.0	V
V_{CE}	Input Voltage (\overline{CE} or CE Input Pin)	-0.3~9.0	V
V_{ADJ}	Input Voltage (ADJ Input Pin)	-0.3~9.0	V
V_{OUT}	Output Voltage	-0.3~ $V_{IN}+0.3$	V
I_{OUT}	Output Current	450	mA
P_D	Power Dissipation (SOT-89-5)*	900	mW
	Power Dissipation (HSO-6)* (Discontinued)	900	
T_{opt}	Operating Temperature Range	-40~85	°C
T_{stg}	Storage Temperature Range	-55~125	°C

*) For Power Dissipation, please refer to PACKAGE INFORMATION.

ABSOLUTE MAXIMUM RATINGS

Electronic and mechanical stress momentarily exceeded absolute maximum ratings may cause the permanent damages and may degrade the life time and safety for both device and system using the device in the field.

The functional operation at or over these absolute maximum ratings is not assured.

RECOMMENDED OPERATING CONDITIONS (ELECTRICAL CHARACTERISTICS)

All of electronic equipment should be designed that the mounted semiconductor devices operate within the recommended operating conditions. The semiconductor devices cannot operate normally over the recommended operating conditions, even if when they are used over such conditions by momentary electronic noise or surge. And the semiconductor devices may receive serious damage when they continue to operate over the recommended operating conditions.

ELECTRICAL CHARACTERISTICS

• R1130xxxxA

T_{opt}=25°C

Symbol	Item	Conditions	Min.	Typ.	Max.	Unit
V _{IN}	Input Voltage		2.5		8.0	V
I _{SS1}	Supply Current 1	V _{IN} -V _{OUT} =1.0V, V _{IN} =GND		50	100	μA
I _{standby}	Standby Current	V _{IN} -V _{OUT} =1.0V, V _{IN} =V _{CE}		0.1	1.0	μA
V _{OUT}	Output Voltage	V _{IN} -V _{OUT} =1.0V 1mA ≤ I _{OUT} ≤ 80mA	V _{OUT} × 0.980	Set V _{OUT}	V _{OUT} × 1.020	V
I _{OUT1}	Output Current	Refer to the table of Input Voltage by Set Output Voltage	300			mA
ΔV _{OUT} /ΔI _{OUT}	Load Regulation	V _{IN} -V _{OUT} =1.0V 1mA ≤ I _{OUT} ≤ 80mA		40	80	mV
V _{DIF}	Dropout Voltage	I _{OUT} =100mA	Refer to the ELECTRICAL CHARACTERISTICS by OUTPUT VOLTAGE			
ΔV _{OUT} /ΔV _{IN}	Line Regulation	I _{OUT} =80mA, Set V _{OUT} >2.0V: V _{OUT} +0.5V ≤ V _{IN} ≤ 8.0V Set V _{OUT} ≤ 1.9V: .5V ≤ V _{IN} ≤ 8.0V		0.1	0.2	%/V
RR	Ripple Rejection	f=1kHz Ripple 0.5Vp-p I _{OUT} = 80mA Set V _{OUT} ≥ 1.8V, V _{IN} -V _{OUT} = 1.0V Set V _{OUT} ≤ 1.7, V _{IN} = 2.8V		60		dB
ΔV _{OUT} /ΔT _{opt}	Output Voltage Temperature Coefficient	I _{OUT} = 30mA, V _{IN} -V _{OUT} = 1.0V -40°C ≤ T _{opt} ≤ 85°C		±100		ppm/°C
I _{sc}	Short Current Limit	Set V _{OUT} ≤ 3.9V, V _{OUT} = 0V		70		mA
		Set V _{OUT} >4.0V, V _{OUT} = 0V		50		
R _{PU}	$\overline{\text{CE}}$ Pull-up Resistance		2.5	5.0	10.0	MΩ
V _{CEH}	$\overline{\text{CE}}$ Input Voltage "H"	V _{IN} =2.5V	1.5		V _{IN}	V
V _{CEL}	$\overline{\text{CE}}$ Input Voltage "L"	V _{IN} =2.5V	0.00		0.25	V

• R1130xxxxB

T_{opt}=25°C

Symbol	Item	Conditions	Min.	Typ.	Max.	Unit
V _{IN}	Input Voltage		2.5		8.0	V
I _{SS1}	Supply Current 1	V _{IN} -V _{OUT} =1.0V, V _{IN} =V _{CE}		50	100	μA
I _{standby}	Standby Current	V _{IN} -V _{OUT} =1.0V, V _{IN} =GND		0.1		μA
V _{OUT}	Output Voltage	V _{IN} -V _{OUT} =1.0V 1mA ≤ I _{OUT} ≤ 80mA	V _{OUT} × 0.980	Set V _{OUT}	V _{OUT} × 1.020	V
I _{OUT1}	Output Current	Refer to the table of Input Voltage by Set Output Voltage	300			mA
ΔV _{OUT} /ΔI _{OUT}	Load Regulation	V _{IN} -V _{OUT} =1.0V 1mA ≤ I _{OUT} ≤ 80mA		40	80	mV
V _{DIF}	Dropout Voltage	I _{OUT} =100mA	Refer to the Table of Dropout Voltage by Set Output Voltage			
ΔV _{OUT} /ΔV _{IN}	Line Regulation	I _{OUT} =80mA, Set V _{OUT} >2.0V: V _{OUT} +0.5V ≤ V _{IN} ≤ 8.0V Set V _{OUT} ≤ 1.9V: 2.5V ≤ V _{IN} ≤ 8.0V		0.1	0.2	%/V
RR	Ripple Rejection	f=1kHz Ripple 0.5Vp-p I _{OUT} = 80mA Set V _{OUT} ≥ 1.8V, V _{IN} -V _{OUT} = 1.0V Set V _{OUT} ≤ 1.7, V _{IN} = 2.8V		60		dB
ΔV _{OUT} / ΔT _{opt}	Output Voltage Temperature Coefficient	I _{OUT} = 10mA, V _{IN} -V _{OUT} = 1.0V -40°C ≤ T _{opt} ≤ 85°C		±100		ppm /°C
I _{sc}	Short Current Limit	Set V _{OUT} ≤ 3.9V, V _{OUT} = 0V		70		mA
		Set V _{OUT} ≥ 4.0V, V _{OUT} = 0V		50		
R _{PU}	Pull-down Resistance for CE pin		2.5	5.0	10.0	MΩ
V _{CEH}	CE Input Voltage "H"	V _{IN} =2.5V	1.5		V _{IN}	V
V _{CEL}	CE Input Voltage "L"	V _{IN} =2.5V	0.00		0.25	V

• Dropout Voltage by Set Output Voltage

T_{opt} = 25°C

Output Voltage V _{OUT} (V)	Dropout Voltage	
	V _{DIF} (V)	
	Typ.	Max.
V _{OUT} = 1.5	1.00	1.05
V _{OUT} = 1.6	0.90	0.95
V _{OUT} = 1.7	0.80	0.85
V _{OUT} = 1.8	0.70	0.75
V _{OUT} = 1.9	0.60	0.65
V _{OUT} = 2.0	0.50	0.60
V _{OUT} = 2.1	0.40	0.55
2.2 ≤ V _{OUT} ≤ 2.5	0.30	0.49
2.6 ≤ V _{OUT} ≤ 3.3	0.25	0.34
3.4 ≤ V _{OUT} ≤ 5.0	0.20	0.28

Dropout Voltage by Set Output Voltage

T_{opt} = 25°C

Output Voltage V _{OUT} (V)	Input Voltage (V)
1.5 ≤ V _{OUT} ≤ 1.9	V _{IN} =V _{OUT} +1.5V
2.0 ≤ V _{OUT} ≤ 2.7	V _{IN} =V _{OUT} +1.3V
2.8 ≤ V _{OUT} ≤ 5.0	V _{IN} =V _{OUT} +1.0V

• R1130xxxxC

T_{opt}=25°C

Symbol	Item	Conditions	Min.	Typ.	Max.	Unit
V _{IN}	Input Voltage		2.5		8.0	V
I _{SS1}	Supply Current	V _{IN} -V _{OUT} =1.0V, V _{IN} =V _{CE}		50	100	μA
I _{standby}	Standby Current	V _{IN} -V _{OUT} =1.0V, V _{IN} =GND		0.1	1.0	μA
V _{OUT}	Reference Voltage for Adjustable Voltage Regulator	V _{OUT} =V _{ADJ} , V _{IN} -V _{OUT} =1.0V I _{OUT} =80mA	1.764	1.800	1.836	V
I _{OUT1}	Output Current	V _{OUT} =V _{ADJ} , V _{IN} -V _{OUT} =1.5V	300			mA
ΔV _{OUT} /ΔI _{OUT}	Load Regulation	V _{IN} =2.5V, V _{OUT} =V _{ADJ} 1mA ≤ I _{OUT} ≤ 80mA		40	80	mV
V _{DIF}	Dropout Voltage	I _{OUT} =100mA, V _{OUT} =V _{ADJ}		0.1	0.2	V
ΔV _{OUT} /ΔV _{IN}	Line Regulation	I _{OUT} =80mA, V _{OUT} =V _{ADJ} 2.5V ≤ V _{IN} ≤ 8.0V		0.1	0.2	%/V
RR	Ripple Rejection	f=1kHz Ripple 0.5Vp-p I _{OUT} = 80mA, V _{IN} -V _{OUT} = 1.0V V _{OUT} =V _{ADJ} , I _{OUT} =80mA		60		dB
ΔV _{OUT} /ΔT _{opt}	Output Voltage Temperature Coefficient	I _{OUT} = 10mA, V _{IN} -V _{OUT} = 1.0V -40°C ≤ T _{opt} ≤ 85°C		±100		ppm/°C
I _{sc}	Short Current Limit	V _{OUT} = 0V		70		mA
R _{PU}	Pull-down Resistance for CE pin		2.5	5.0	10.0	MΩ
V _{CEH}	CE Input Voltage "H"	V _{IN} =2.5V	1.5		V _{IN}	V
V _{CEL}	CE Input Voltage "L"	V _{IN} =2.5V	0.00		0.25	V

TEST CIRCUITS (Pin number is applied to R1130H Series)

- R1130HxxxA

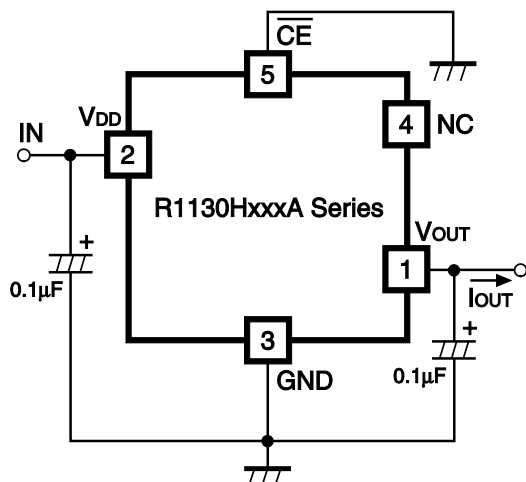

Fig.1 Standard test Circuit

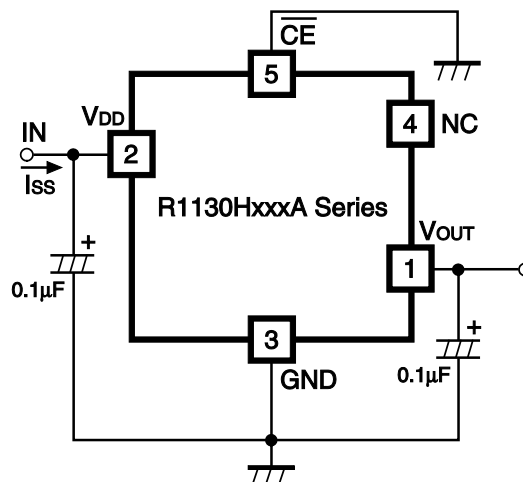

Fig.2 Supply Current Test Circuit

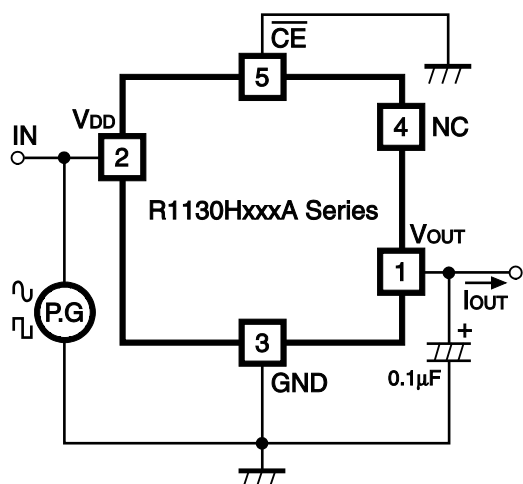

Fig.3 Ripple Rejection, Line Transient Response Test Circuit

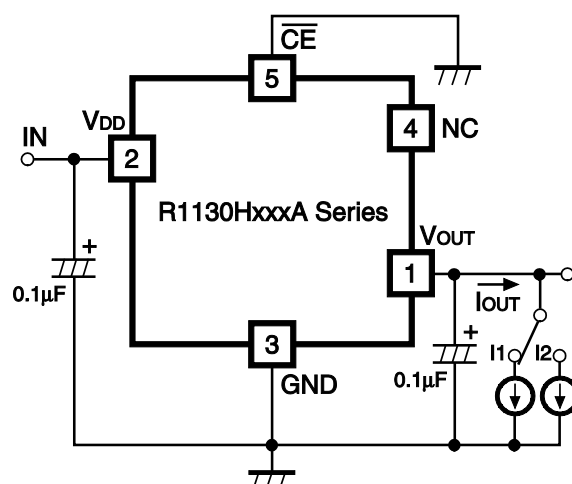

Fig.4 Load Transient Response Test Circuit

• R1130HxxxB

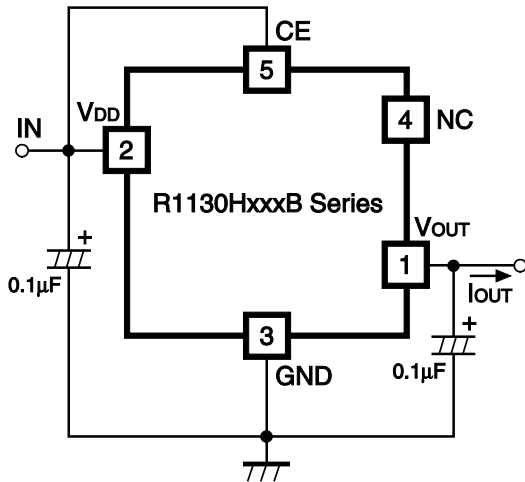

Fig.1 Standard test Circuit

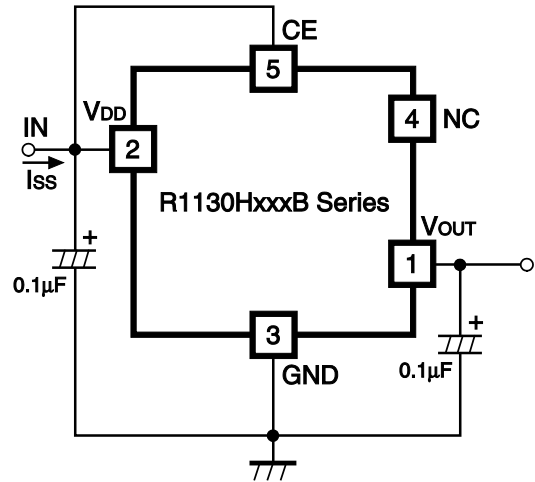

Fig.2 Supply Current Test Circuit

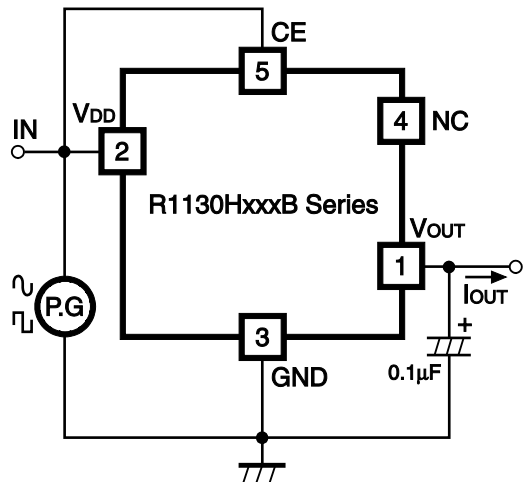

Fig.3 Test Circuit for Ripple Rejection and Input Transient Response

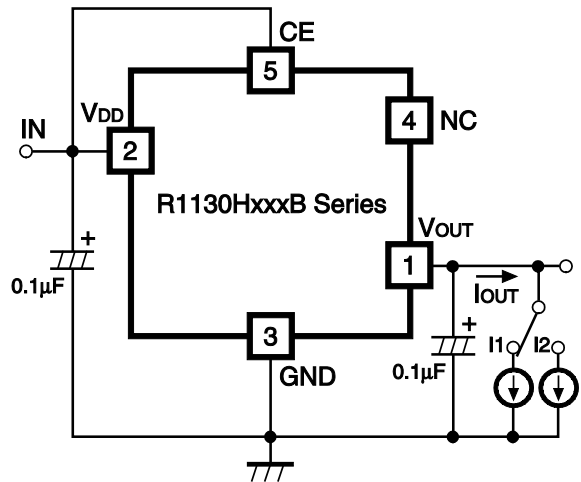

Fig.4 Test Circuit for Load Transient Response

- R1130H001C

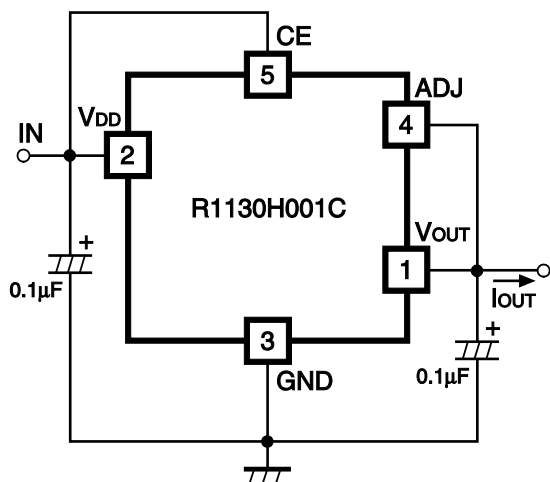

Fig.1 Standard test Circuit

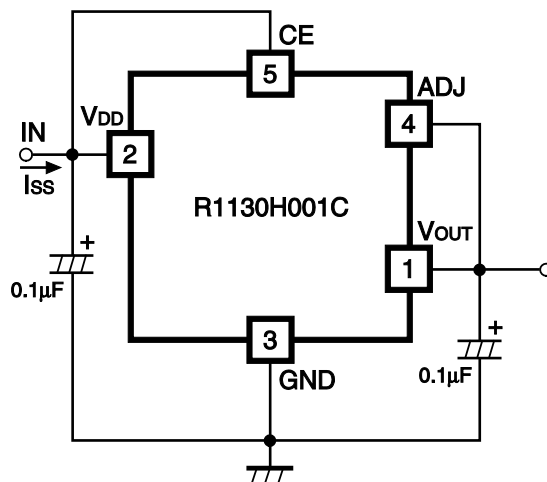

Fig.2 Test Circuit Supply Current

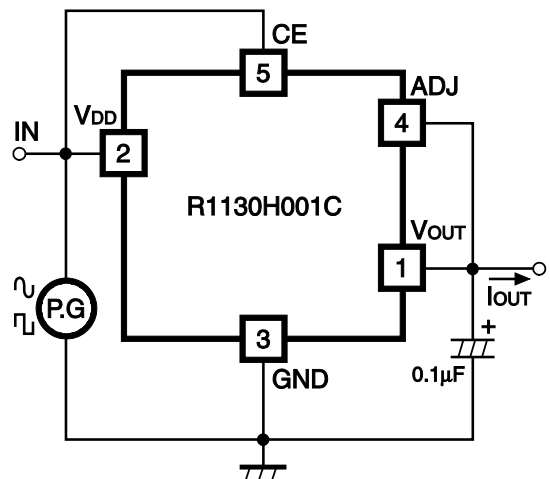

Fig.3 Test Circuit for Ripple Rejection and Input Transient Response

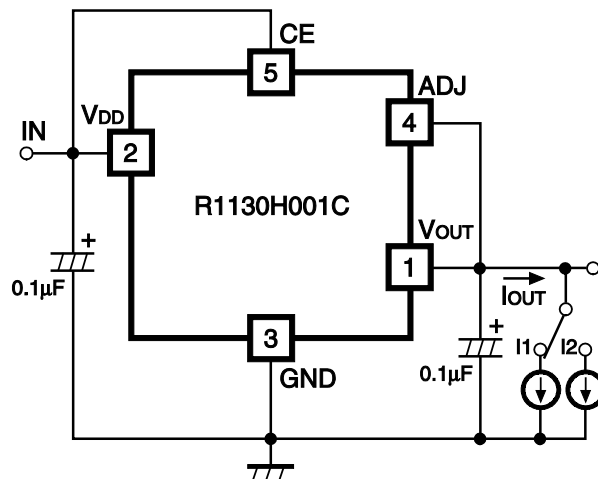
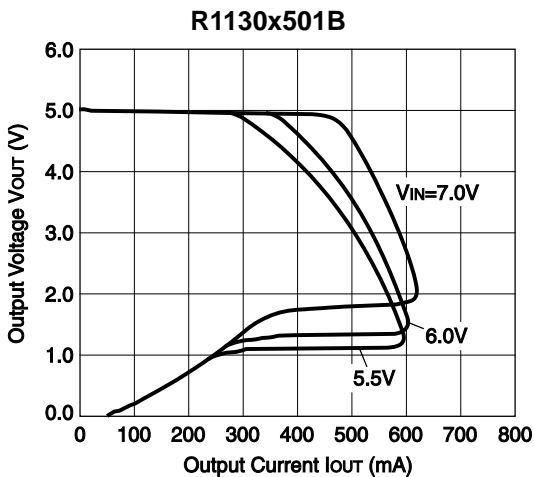
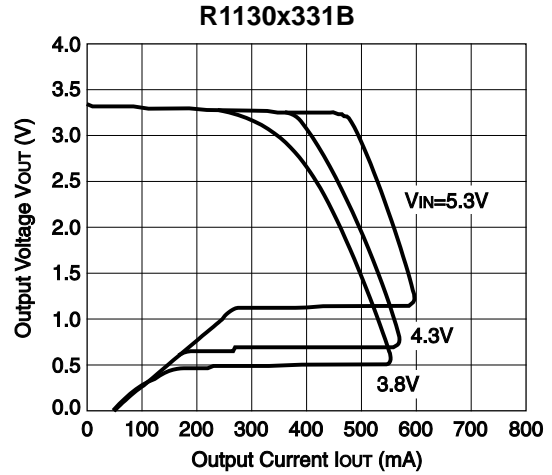
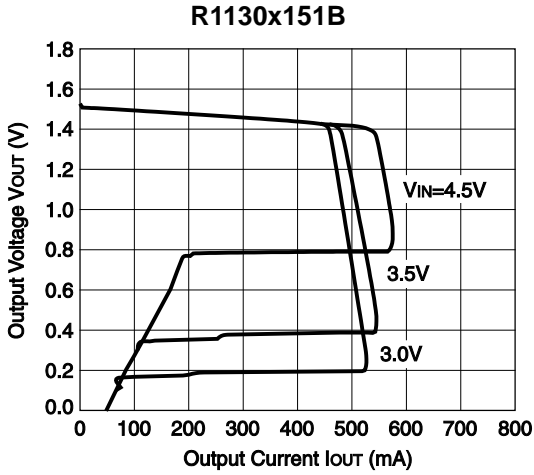

Fig.4 Test Circuit for Load Transient Response

TYPICAL CHARACTERISTICS

1) Output Voltage vs. Output Current (Topt=25°C)



2) Input Voltage vs. Output Voltage (Topt=25°C)

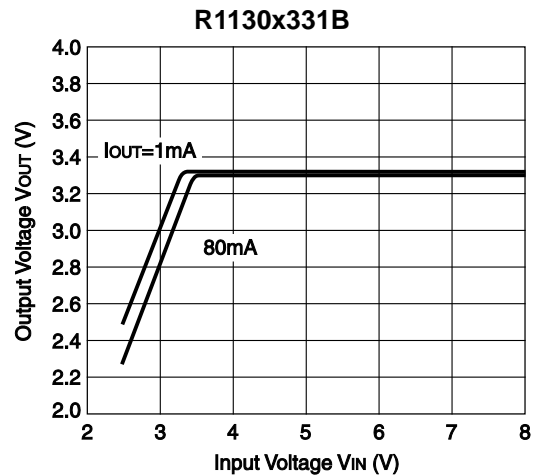
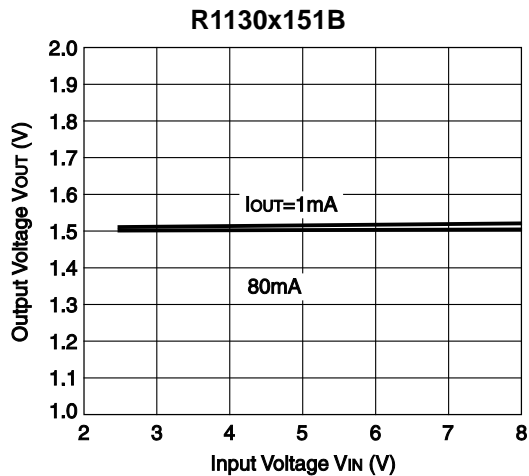

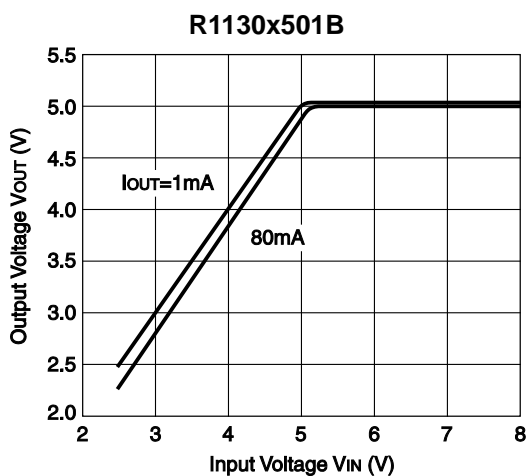

3) Dropout Voltage vs. Output Current

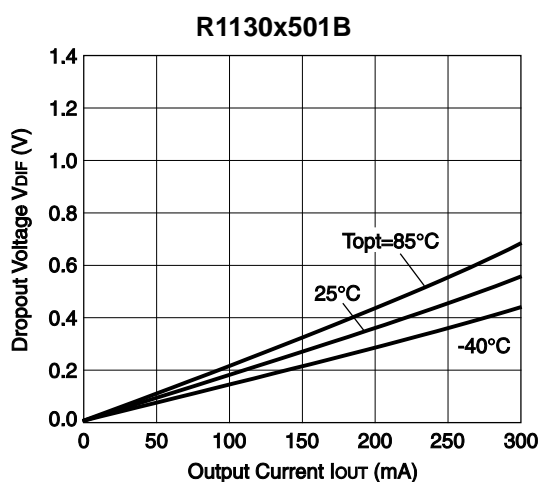
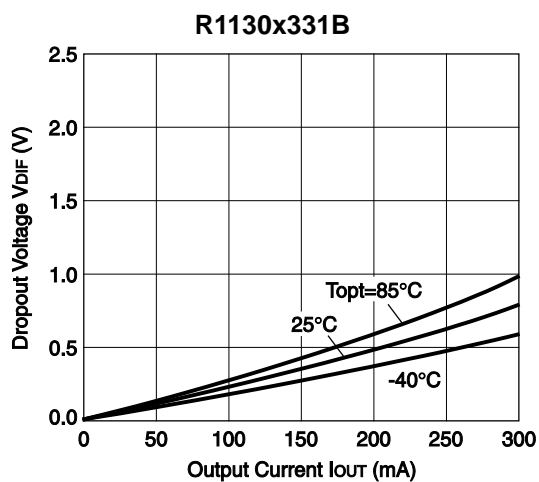
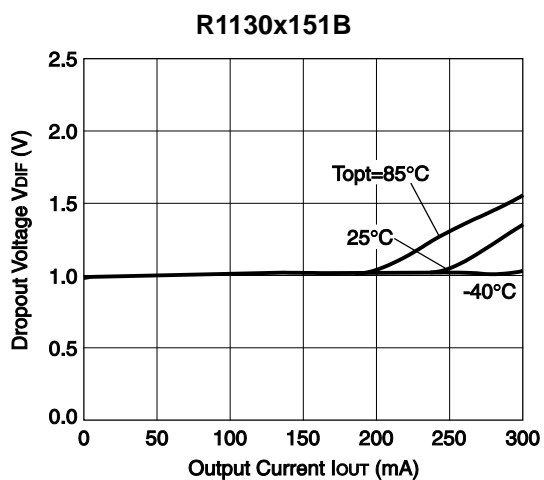

R1130x

4) Output Voltage vs. Temperature

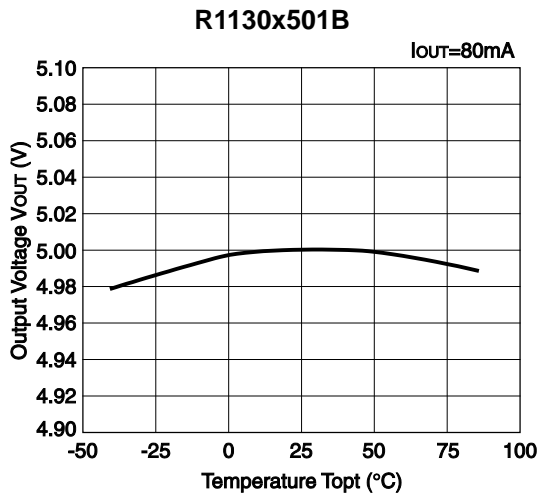
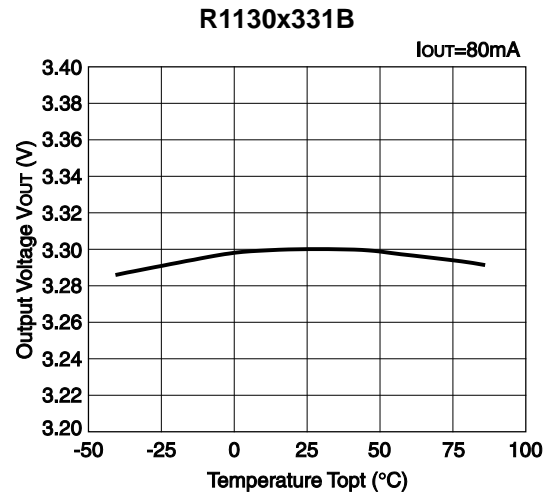
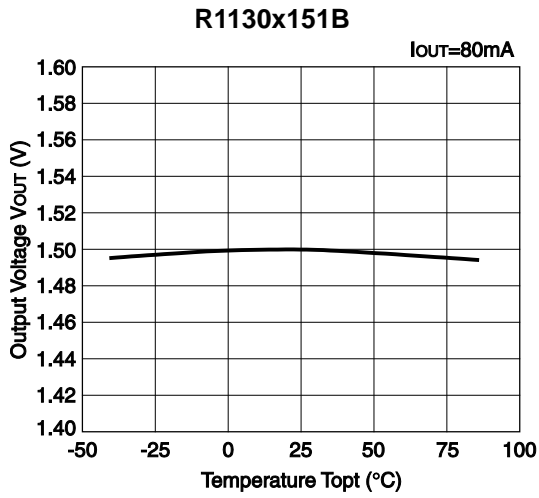

5) Supply Current vs. Input Voltage (T_{opt}=25°C)

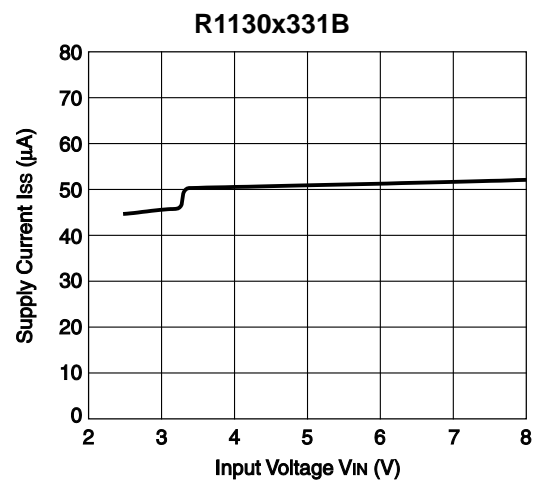
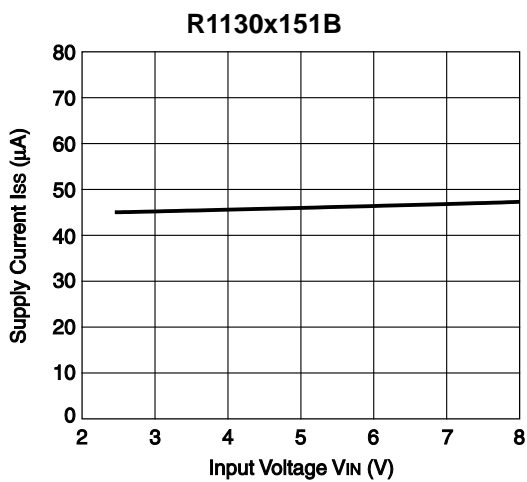

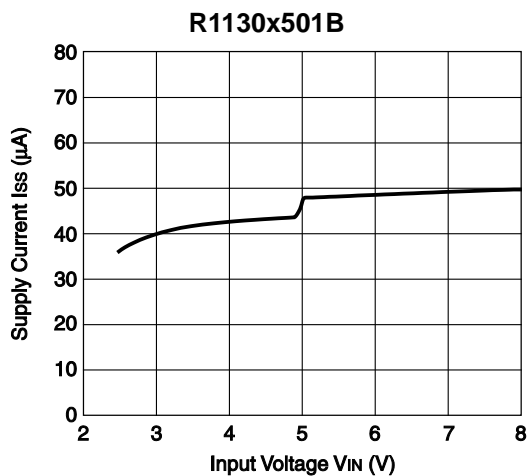

6) Supply Current vs. Temperature

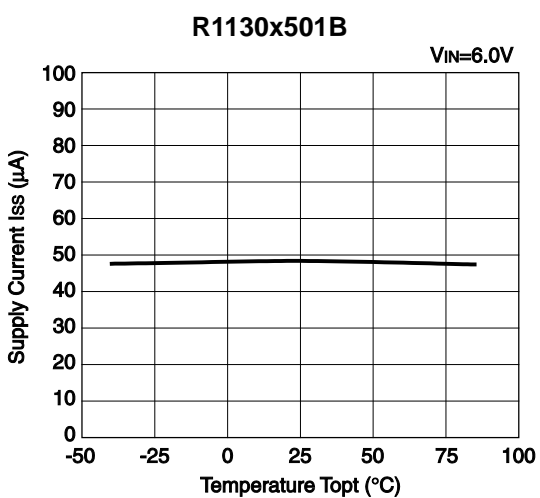
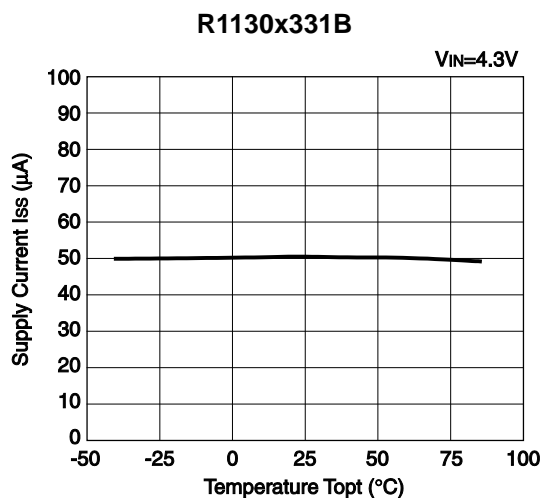
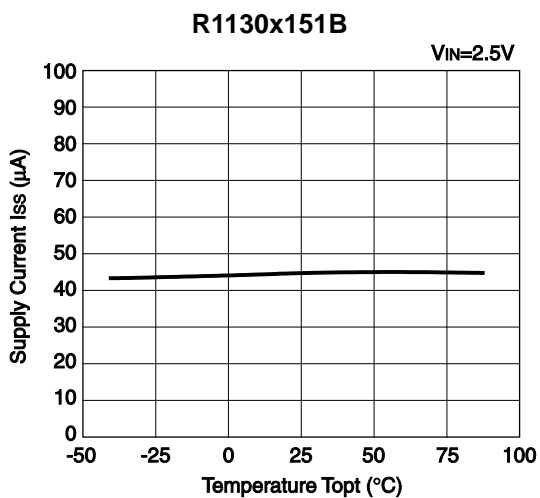

R1130x

7) Ripple Rejection vs. Frequency

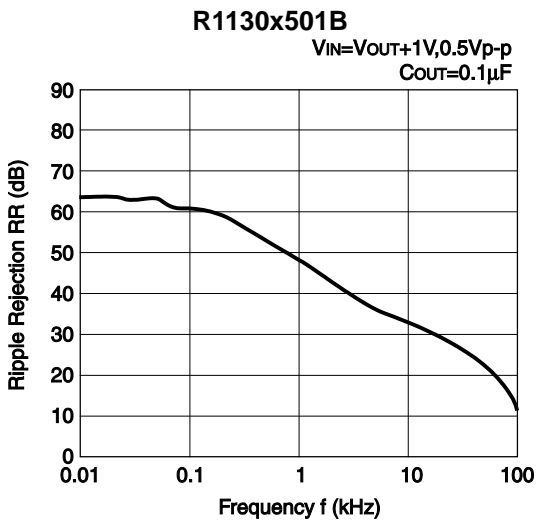
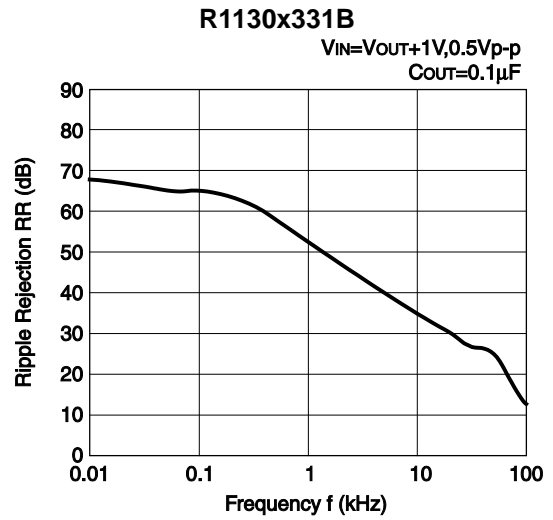
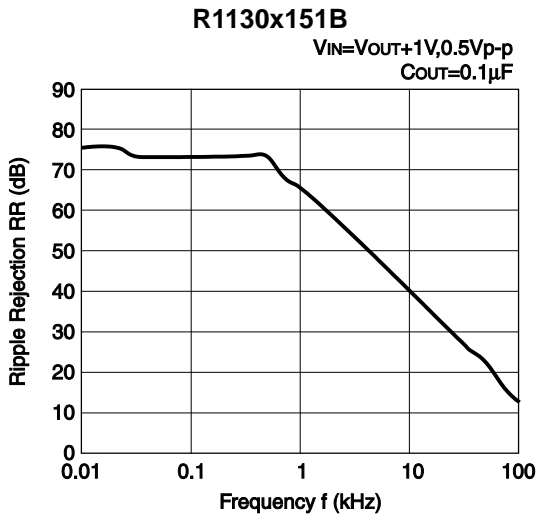

8) Ripple Rejection vs. Input Voltage

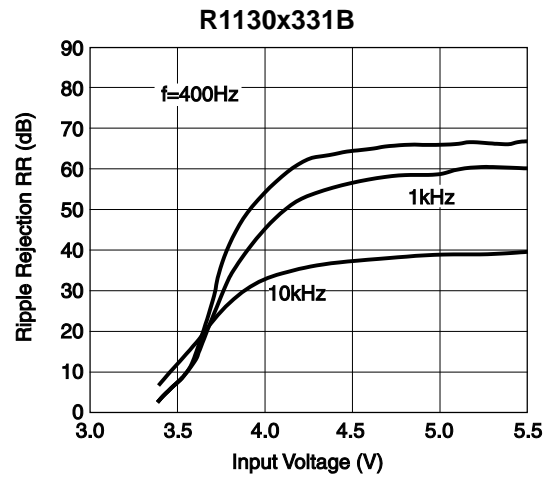
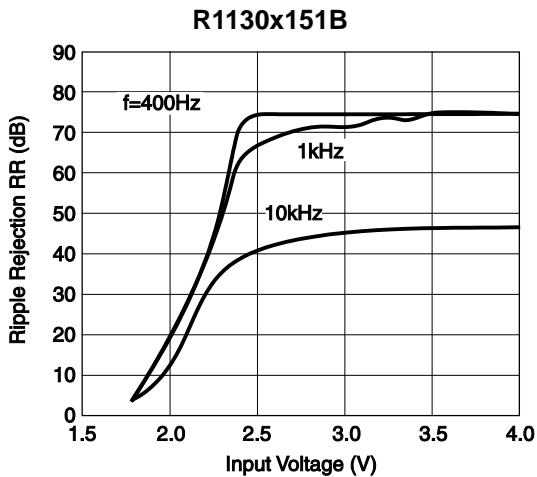

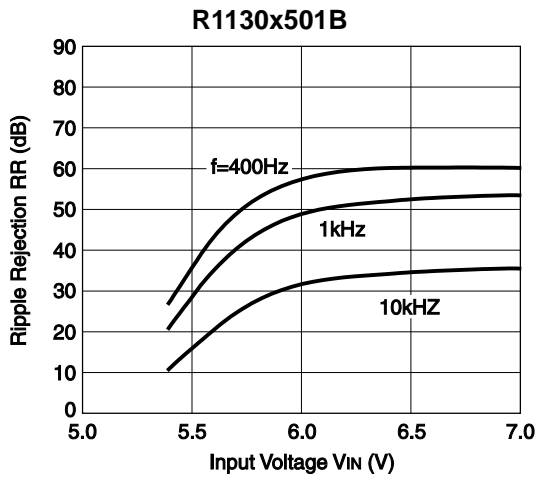

9) Input Transient Response

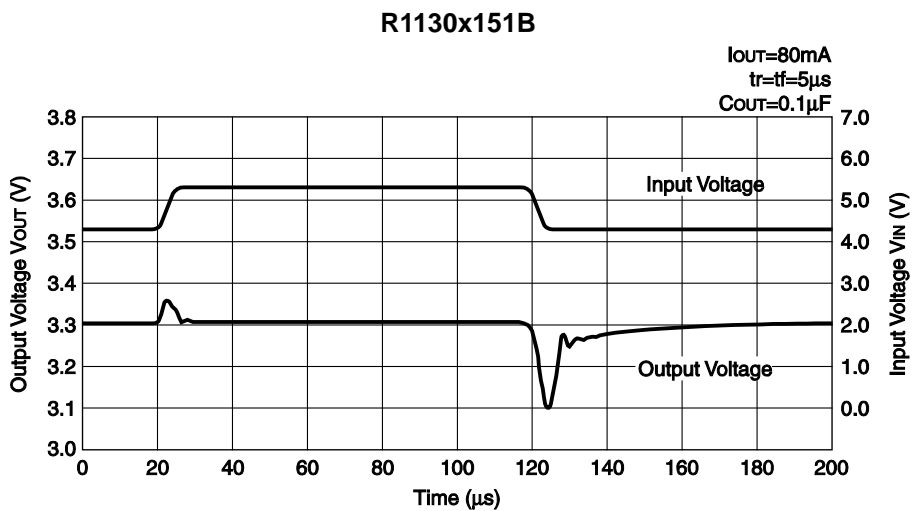
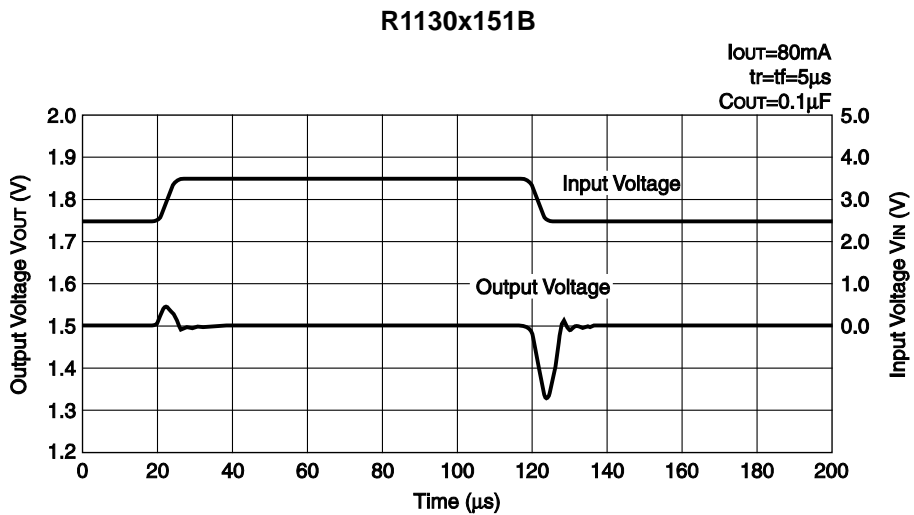

R1130x501B

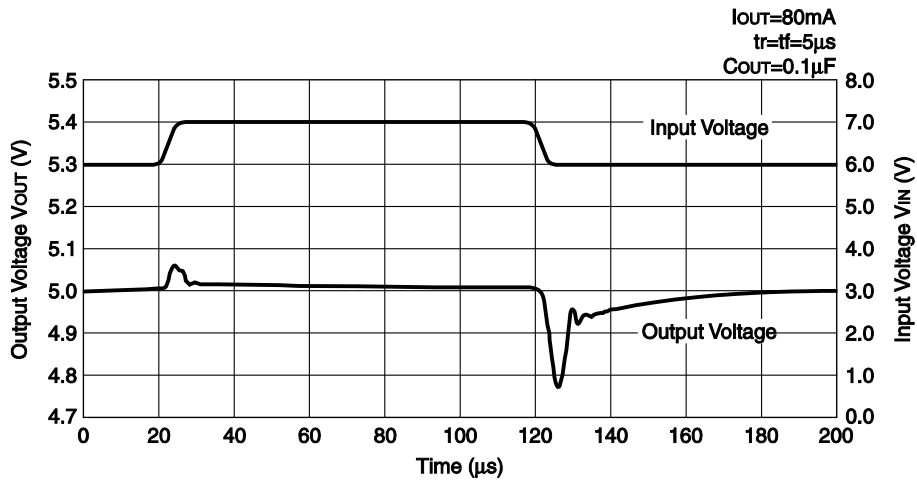

10) Load Transient Response

R1130x151B

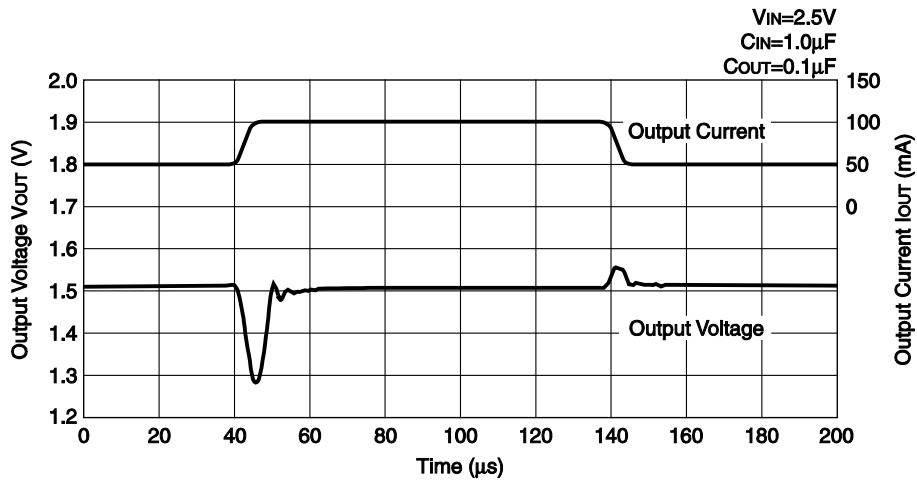

R1130x331B

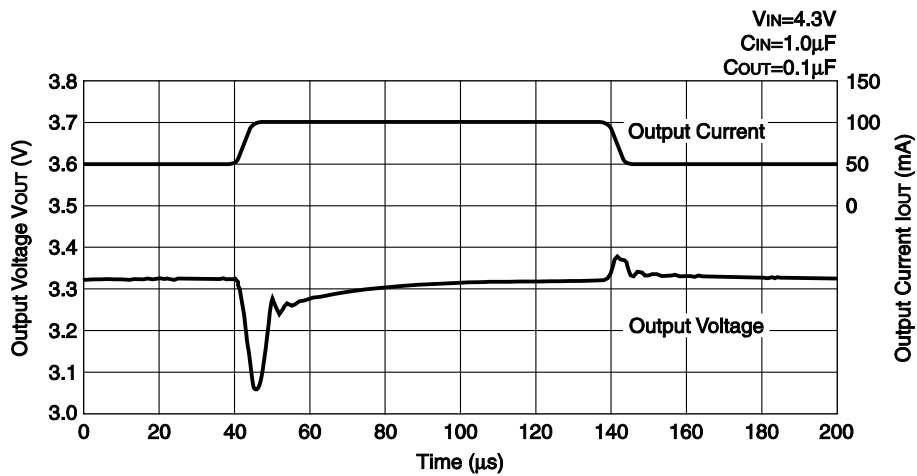

R1130x501B

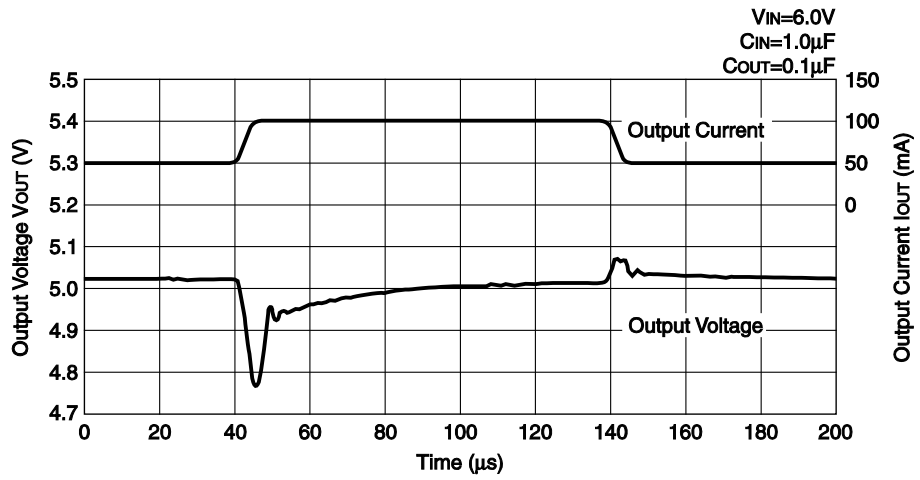

APPENDIX

* Technical Notes on Output Voltage Setting of C type

Figure 1. Adjustable Regulator (C type)

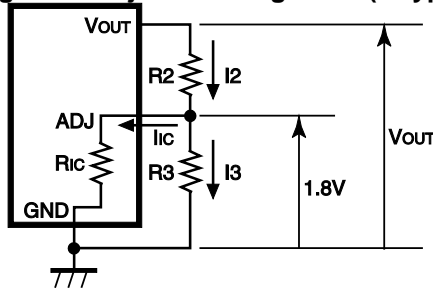

The Output Voltage of Regulator in R1130xxxxC may be adjustable for any output voltage between its 1.8V reference and its V_{DD} setting level. An external pair of resistors is required, as shown in Figure 1.

The complete equation for the output voltage is described step by step as follows;

$$I_2 = I_{ic} + I_3 \quad \dots\dots\dots (1)$$

$$I_3 = 1.8/R_3 \quad \dots\dots\dots (2)$$

Thus,

$$I_2 = I_{ic} + 1.8/R_3 \quad \dots\dots\dots (3)$$

Therefore,

$$V_{OUT} = 1.8 + R_2 \times I_2 \quad \dots\dots\dots (4)$$

Put Equation (3) into Equation (4), then

$$\begin{aligned} V_{OUT} &= 1.8 + R_2 \times (I_{ic} + 1.8/R_3) \\ &= 1.8 \times (1 + R_2/R_3) + R_2 \times I_{ic} \quad \dots\dots\dots (5) \end{aligned}$$

In 2nd term, or $R_2 \times I_{ic}$ will produce an error in V_{OUT} .

In Equation (5),

$$I_{ic} = 1.8/R_{ic} \quad \dots\dots\dots (6)$$

$$\begin{aligned} R_2 \times I_{ic} &= R_2 \times 1.8/R_{ic} \\ &= 1.8 \times R_2/R_{ic} \quad \dots\dots\dots (7) \end{aligned}$$

For better accuracy, choosing $R_2 \ll R_{ic}$ reduces this error.

* Adjustable Resistor Dependence of Output Voltage

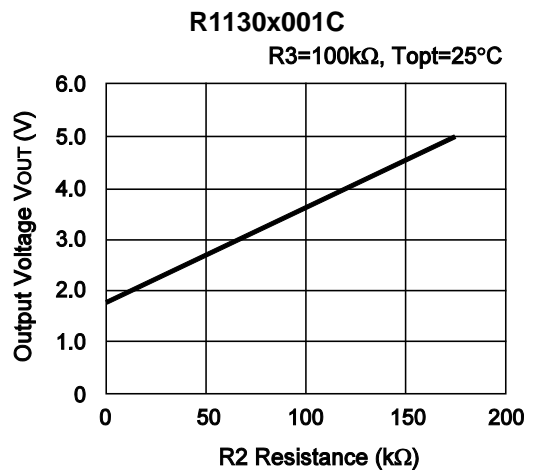
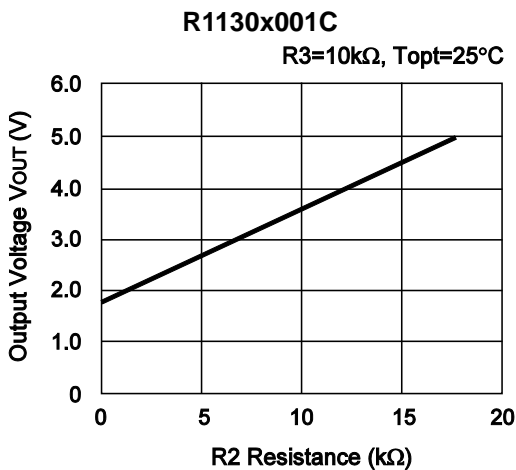

TYPICAL APPLICATION

R1130xxxxA

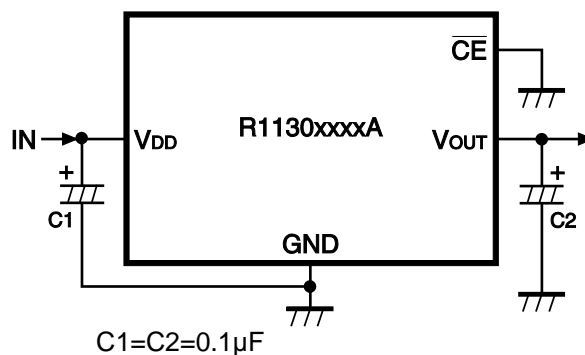

R1130xxxxB

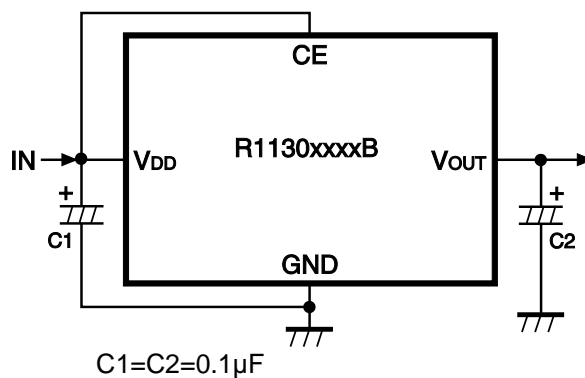

R1130xxxxC

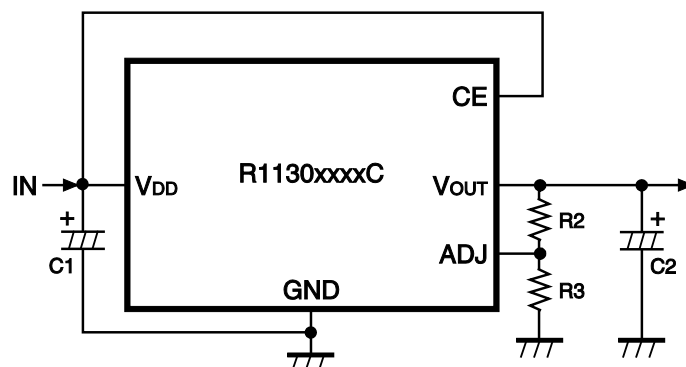

$C1=C2=0.1\mu\text{F}$, R2, R3: Refer to the Technical Notes on Output Voltage setting of C type.



1. The products and the product specifications described in this document are subject to change or discontinuation of production without notice for reasons such as improvement. Therefore, before deciding to use the products, please refer to our sales representatives for the latest information thereon.
2. The materials in this document may not be copied or otherwise reproduced in whole or in part without prior written consent of our company.
3. Please be sure to take any necessary formalities under relevant laws or regulations before exporting or otherwise taking out of your country the products or the technical information described herein.
4. The technical information described in this document shows typical characteristics of and example application circuits for the products. The release of such information is not to be construed as a warranty of or a grant of license under our company's or any third party's intellectual property rights or any other rights.
5. The products listed in this document are intended and designed for use as general electronic components in standard applications (office equipment, telecommunication equipment, measuring instruments, consumer electronic products, amusement equipment etc.). Those customers intending to use a product in an application requiring extreme quality and reliability, for example, in a highly specific application where the failure or misoperation of the product could result in human injury or death (aircraft, spacevehicle, nuclear reactor control system, traffic control system, automotive and transportation equipment, combustion equipment, safety devices, life support system etc.) should first contact us.
6. We are making our continuous effort to improve the quality and reliability of our products, but semiconductor products are likely to fail with certain probability. In order to prevent any injury to persons or damages to property resulting from such failure, customers should be careful enough to incorporate safety measures in their design, such as redundancy feature, fire containment feature and fail-safe feature. We do not assume any liability or responsibility for any loss or damage arising from misuse or inappropriate use of the products.
7. Anti-radiation design is not implemented in the products described in this document.
8. The X-ray exposure can influence functions and characteristics of the products. Confirm the product functions and characteristics in the evaluation stage.
9. WLCSP products should be used in light shielded environments. The light exposure can influence functions and characteristics of the products under operation or storage.
10. There can be variation in the marking when different AOI (Automated Optical Inspection) equipment is used. In the case of recognizing the marking characteristic with AOI, please contact our sales or our distributor before attempting to use AOI.
11. Please contact our sales representatives should you have any questions or comments concerning the products or the technical information.



Nisshinbo Micro Devices Inc.

Official website

<https://www.nisshinbo-microdevices.co.jp/en/>

Purchase information

<https://www.nisshinbo-microdevices.co.jp/en/buy/>

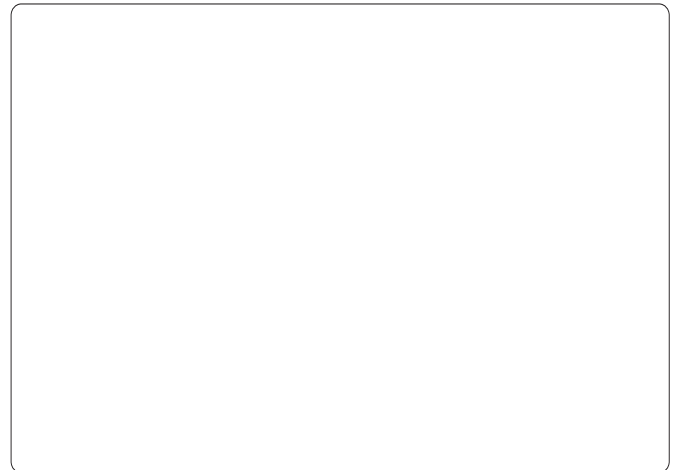

X-ON Electronics

Largest Supplier of Electrical and Electronic Components

Click to view similar products for [LDO Voltage Regulators](#) category:

Click to view products by [Nisshinbo](#) manufacturer:

Other Similar products are found below :

[AP7363-SP-13](#) [NCV8664CST33T3G](#) [L79M05TL-E](#) [AP7362-HA-7](#) [PT7M8202B12TA5EX](#) [TCR3DF185,LM\(CT](#) [TLF4949EJ](#)
[NCP4687DH15T1G](#) [NCV8703MX30TCG](#) [LP2951CN](#) [NCV4269CPD50R2G](#) [AP7315-25W5-7](#) [NCV47411PAAJR2G](#) [AP2111H-1.2TRG1](#)
[ZLDO1117QK50TC](#) [AZ1117ID-ADJTRG1](#) [NCV4263-2CPD50R2G](#) [NCP706ABMX300TAG](#) [NCP114BMX075TCG](#) [MC33269T-3.5G](#)
[TLE4471GXT](#) [AP7315-33SA-7](#) [NCV4266-2CST33T3G](#) [NCP715SQ15T2G](#) [NCV8623MN-50R2G](#) [NCV563SQ18T1G](#) [NCV8664CDT33RKG](#)
[NCV4299CD250R2G](#) [NCP715MX30TBG](#) [NCV8702MX25TCG](#) [TLE7270-2E](#) [NCV562SQ25T1G](#) [AP2213D-3.3TRG1](#) [AP2202K-2.6TRE1](#)
[NCV8170BMX300TCG](#) [NCV8152MX300180TCG](#) [NCP700CMT45TBG](#) [AP7315-33W5-7](#) [NCP154MX180300TAG](#) [AP2113AMTR-G1](#)
[NJW4104U2-33A-TE1](#) [MP2013AGG-5-P](#) [NCV8775CDT50RKG](#) [NJM2878F3-45-TE1](#) [S-19214B00A-V5T2U7](#) [S-19214B50A-V5T2U7](#) [S-](#)
[19213B50A-V5T2U7](#) [S-19214BC0A-E8T1U7*1](#) [S-19213B00A-V5T2U7](#) [S-19213B33A-V5T2U7](#)