



R1163x SERIES

3-MODE 150mA LDO REGULATOR with the Reverse Current Protection

NO.EA-118-230417

OUTLINE

The R1163x Series consist of CMOS-based voltage regulator ICs with high output voltage accuracy and low supply current. These ICs perform with the chip enable function and realize a standby mode with ultra low supply current. To prevent the destruction by over current, the current limit circuit is included. The R1163x Series have 3-mode. One is standby mode with CE or standby control pin. Other two modes are realized with ECO pin. Fast Transient Mode (FT mode) and Low Power Mode (LP mode) are alternative with ECO pin. Consumption current is reduced at Low Power Mode compared with Fast Transient Mode. The output voltage is maintained between FT mode and LP mode.

Further, the reverse current protection circuit is built-in. Therefore, if a higher voltage than V_{DD} pin is forced to the output pin, the reverse current to V_{DD} pin is very small (Max. $0.1\mu\text{A}$), so it is suitable for backup circuit.

Since the packages for these ICs are SOT-23-5, SON-6, and DFN(PL)1616-6 packages, high density mounting of the ICs on boards is possible.

FEATURES

- Supply Current Typ. $6.0\mu\text{A}$ (Low Power Mode),
Typ. $70\mu\text{A}$ (Fast Transient Mode)
- Standby Mode Typ. $0.6\mu\text{A}$
- Reverse Current Max. $0.1\mu\text{A}$
- Input Voltage Range 2.0V to 6.0V
- Output Voltage Range 1.5V to 5.0V (0.1V steps)
(For other voltages, please refer to MARK INFORMATIONS.)
- Output Voltage Accuracy $\pm 1.5\%$ ($\pm 2.5\%$ at Low Power Mode)
- Temperature-Drift Coefficient of Output Voltage .. Typ. $\pm 100\text{ppm}/^\circ\text{C}$
- Dropout Voltage Typ. 0.25V ($I_{\text{OUT}}=150\text{mA}$, $V_{\text{OUT}}=2.8\text{V}$)
- Ripple Rejection Typ. 70dB ($f=1\text{kHz}$, Fast Transient Mode)
- Line Regulation Typ. $0.02\%/V$ (Fast Transient Mode)
- Packages DFN(PL)1616-6, SOT-23-5, SON-6
- Built-in fold-back protection circuit Typ. 40mA (Current at short mode)
- Performs with Ceramic Capacitors $C_{\text{IN}}=\text{Ceramic } 1.0\mu\text{F}$, $C_{\text{OUT}}=\text{Ceramic } 0.47\mu\text{F}$

APPLICATIONS

- Precision Voltage References.
- Power source for electrical appliances such as cameras, VCRs and hand-held communication equipment.
- Power source for battery-powered equipment.

BLOCK DIAGRAM

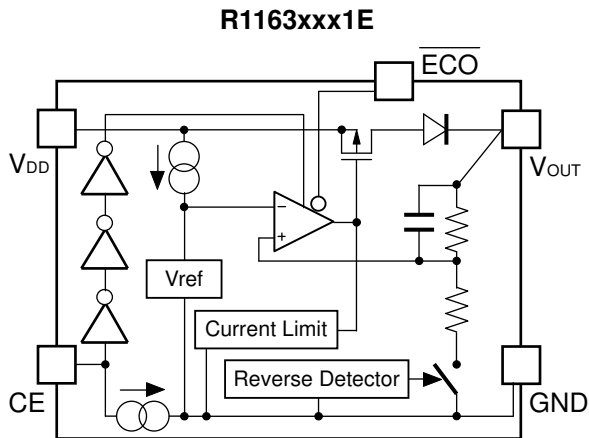
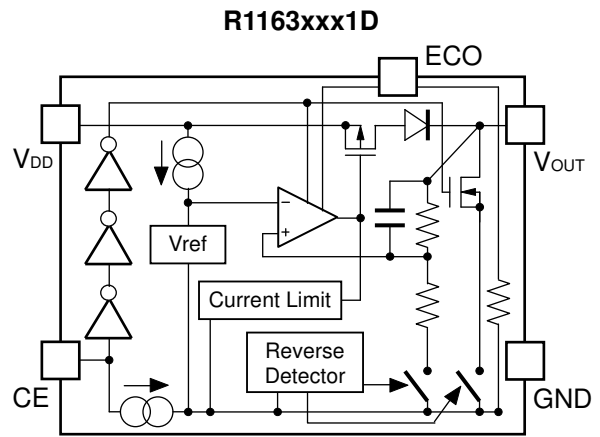
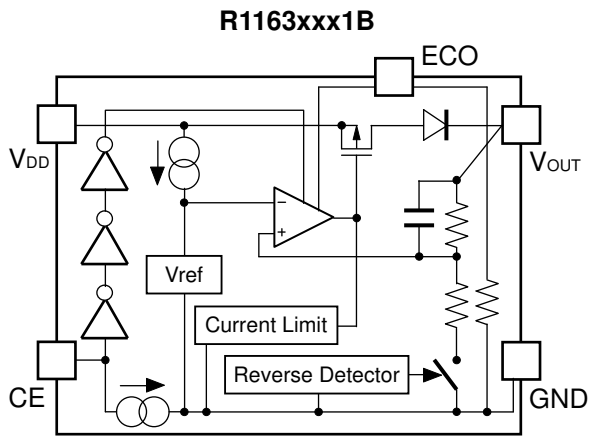

SELECTION GUIDE

The output voltage, auto discharge function, and package, etc. for the ICs can be selected at the user's request.

Product Name	Package	Quantity per Reel	Pb Free	Halogen Free
R1163Kxx1*-TR	DFN(PL)1616-6	5,000 pcs	Yes	Yes
R1163Nxx1*-TR-FE	SOT-23-5	3,000 pcs	Yes	Yes
R1163Dxx1*-TR-FE	SON-6	3,000 pcs	Yes	Yes

xx: The output voltage can be designated in the range from 1.5V(15) to 5.0V(50) in 0.1V steps.
(For other voltages, please refer to MARK INFORMATIONS.)

* : The auto discharge function at off state are options as follows.
(B) without auto discharge function at off state
(D) with auto discharge function at off state
(E) without auto discharge function at off state, ECO logic reverse type (Low Power mode at ECO="H")

PIN CONFIGURATIONS

• DFN(PL)1616-6

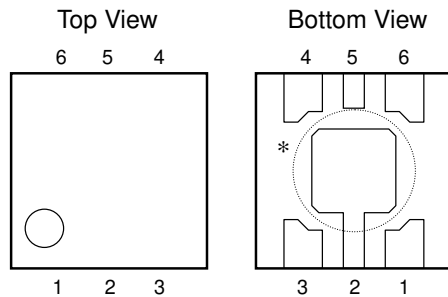

• SOT-23-5

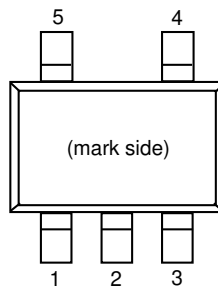

• SON-6

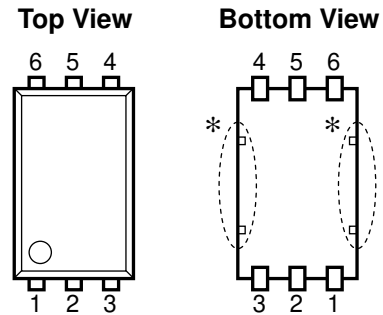

PIN DISCRIPTIONS

• DFN(PL)1616-6

Pin No	Symbol	Pin Description
1	V_{OUT}	Output pin
2	GND	Ground Pin
3	ECO	R1163xxx1B/D: FT/LP Mode Alternative Pin ("L" LP)
	\overline{ECO}	R1163xxx1E: FT/LP Mode Alternative Pin ("H" LP)
4	CE	Chip Enable pin ("H" Active)
5	NC	No Connection
6	V_{DD}	Input Pin

*) Tab is GND level. (They are connected to the reverse side of this IC.)

The tab is better to be connected to the GND, but leaving it open is also acceptable.

• SOT-23-5

Pin No	Symbol	Pin Description
1	V_{DD}	Input Pin
2	GND	Ground Pin
3	CE	Chip Enable Pin ("H" Active)
4	ECO	R1163xxx1B/D: FT/LP Mode Alternative Pin ("L" LP)
	\overline{ECO}	R1163xxx1E: FT/LP Mode Alternative Pin ("H" LP)
5	V_{OUT}	Output pin

• SON-6

Pin No	Symbol	Pin Description
1	V_{DD}	Input Pin
2	NC	No Connection
3	V_{OUT}	Output pin
4	ECO	R1163xxx1B/D: FT/LP Mode Alternative Pin ("L" LP)
	\overline{ECO}	R1163xxx1E: FT/LP Mode Alternative Pin ("H" LP)
5	GND	Ground Pin
6	CE	Chip Enable Pin ("H" Active)

*) Tab suspension leads are GND level. (They are connected to the reverse side of this IC.)

The tab suspension leads should be open and do not connect to other wires or land patterns.

ABSOLUTE MAXIMUM RATINGS

Symbol	Item	Rating	Unit
V _{IN}	Input Voltage	6.5	V
V _{ECO}	Input Voltage (ECO/ $\overline{\text{ECO}}$ Pin)	-0.3 ~ 6.5	V
V _{CE}	Input Voltage (CE Pin)	-0.3 ~ 6.5	V
V _{OUT}	Output Voltage	-0.3 ~ 6.5	V
I _{OUT}	Output Current	180	mA
P _D	Power Dissipation (DFN(PL)1616-6)*	640	mW
	Power Dissipation (SOT-23-5) *	420	
	Power Dissipation (SON-6) *	500	
T _{opt}	Operating Temperature Range	-40 ~ 85	°C
T _{stg}	Storage Temperature Range	-55 ~ 125	°C

*) For Power Dissipation, please refer to PACKAGE INFORMATION.

ABSOLUTE MAXIMUM RATINGS

Electronic and mechanical stress momentarily exceeded absolute maximum ratings may cause the permanent damages and may degrade the life time and safety for both device and system using the device in the field.

The functional operation at or over these absolute maximum ratings is not assured.

RECOMMENDED OPERATING CONDITIONS (ELECTRICAL CHARACTERISTICS)

All of electronic equipment should be designed that the mounted semiconductor devices operate within the recommended operating conditions. The semiconductor devices cannot operate normally over the recommended operating conditions, even if when they are used over such conditions by momentary electronic noise or surge. And the semiconductor devices may receive serious damage when they continue to operate over the recommended operating conditions.

ELECTRICAL CHARACTERISTICS

R1163xxx1B/D

T_{opt}=25°C

Symbol	Item	Conditions	Min.	Typ.	Max.	Unit	
V _{OUT}	Output Voltage	FT Mode	V _{IN} =Set V _{OUT} +1V, V _{ECO} =V _{IN} 1mA ≤ I _{OUT} ≤ 30mA	×0.985		×1.015	V
		LP Mode	V _{IN} =Set V _{OUT} +1V, V _{ECO} =GND 1mA ≤ I _{OUT} ≤ 30mA	×0.975		×1.025	
ΔV _{OUT}	Output Voltage Deviation between FT Mode and LP Mode	V _{IN} =Set V _{OUT} +1V, I _{OUT} =30mA	V _{OUT} > 2.0V	-1.2	0	1.2	%
			V _{OUT} ≤ 2.0V	-24	0	24	mV
I _{OUT}	Output Current	V _{IN} -V _{OUT} =1.0V	150			mA	
ΔV _{OUT} / ΔI _{OUT}	Load Regulation	FT Mode	V _{IN} =Set V _{OUT} +1V, V _{ECO} =V _{IN} 1mA ≤ I _{OUT} ≤ 150mA		20	40	mV
		LP Mode	V _{IN} =Set V _{OUT} +1V, V _{ECO} =GND 1mA ≤ I _{OUT} ≤ 150mA		20	45	
V _{DIF}	Dropout Voltage	Refer to the following table					
I _{SS1}	Supply Current (FT Mode)	V _{IN} =Set V _{OUT} +1V V _{ECO} =V _{IN}		70	100	μA	
I _{SS2}	Supply Current (LP Mode)	V _{IN} =Set V _{OUT} +1V V _{ECO} =GND		6.0	10.0	μA	
I _{standby}	Supply Current (Standby)	V _{IN} =Set V _{OUT} +1V, V _{CE} =GND V _{ECO} =GND or V _{IN}		0.6	1.0	μA	
ΔV _{OUT} / ΔV _{IN}	Line Regulation	FT Mode	Set V _{OUT} +0.5V ≤ V _{IN} ≤ 6.0V I _{OUT} =30mA, V _{ECO} =V _{IN} If V _{OUT} ≤ 1.6V, then 2.2V ≤ V _{IN} ≤ 6.0V		0.02	0.10	%V
		LP Mode	Set V _{OUT} +0.5V ≤ V _{IN} ≤ 6.0V I _{OUT} =30mA, V _{ECO} =GND If V _{OUT} ≤ 1.6V, then 2.2V ≤ V _{IN} ≤ 6.0V		0.05	0.20	
RR	Ripple Rejection (FT Mode)	Ripple 0.2V _{p-p} , V _{IN} =Set V _{OUT} +1V, I _{OUT} =30mA, V _{ECO} =V _{IN} If V _{OUT} ≤ 1.7V, then V _{IN} =Set V _{OUT} +1.2V	f=1kHz		70	dB	
			f=10kHz		60		
V _{IN}	Input Voltage		2.0		6.0	V	
ΔV _{OUT} / ΔT _{opt}	Output Voltage Temperature Coefficient	I _{OUT} =30mA -40°C ≤ T _{opt} ≤ 85°C		±100		ppm /°C	
I _{SC}	Short Current Limit	V _{OUT} =0V		40		mA	
I _{PD}	CE Pull-down Current			0.3	0.6	μA	
R _{PDE}	ECO Pull-down Resistance		2	5	30	MΩ	
V _{CEH}	CE, ECO Input Voltage "H"		1.0		6.0	V	
V _{CEL}	CE, ECO Input Voltage "L"		0		0.35	V	
en	Output Noise "H" (FT Mode)	BW=10Hz to 100kHz		30		μV _{rms}	
	Output Noise "L" (LP Mode)	BW=10Hz to 100kHz		40			
R _{LOW}	Low Output Nch Tr. ON Resistance (of D version)	V _{CE} =0V		60		Ω	
I _{REV}	Reverse Current	V _{OUT} >0.5V, 0V ≤ V _{IN} ≤ 6V		0	0.1	μA	

R1163xxx1E

T_{opt}=25°C

Symbol	Item	Conditions	Min.	Typ.	Max.	Unit	
V _{OUT}	Output Voltage	FT Mode	V _{IN} =Set V _{OUT} +1V, V _{ECO} =GND 1mA ≤ I _{OUT} ≤ 30mA	×0.985		×1.015	V
		LP Mode	V _{IN} =Set V _{OUT} +1V, V _{ECO} =V _{IN} 1mA ≤ I _{OUT} ≤ 30mA	×0.975		×1.025	
ΔV _{OUT}	Output Voltage Deviation between FT Mode and LP Mode	V _{IN} =Set V _{OUT} +1V, I _{OUT} =30mA	V _{OUT} > 2.0V	-1.2	0	1.2	%
			V _{OUT} ≤ 2.0V	-24	0	24	mV
I _{OUT}	Output Current	V _{IN} -V _{OUT} =1.0V	150			mA	
ΔV _{OUT} / ΔI _{OUT}	Load Regulation	FT Mode	V _{IN} =Set V _{OUT} +1V, V _{ECO} =GND 1mA ≤ I _{OUT} ≤ 150mA		20	40	mV
		LP Mode	V _{IN} =Set V _{OUT} +1V, V _{ECO} =V _{IN} 1mA ≤ I _{OUT} ≤ 150mA		20	45	
V _{DIF}	Dropout Voltage	Refer to the following table					
I _{SS1}	Supply Current (FT Mode)	V _{IN} =Set V _{OUT} +1V V _{ECO} =GND		70	100	μA	
I _{SS2}	Supply Current (LP Mode)	V _{IN} =Set V _{OUT} +1V V _{ECO} =V _{IN}		6.0	10.0	μA	
I _{standby}	Supply Current (Standby)	V _{IN} =Set V _{OUT} +1V, V _{CE} =GND V _{ECO} =GND or V _{IN}		0.6	1.0	μA	
ΔV _{OUT} / ΔV _{IN}	Line Regulation	FT Mode	Set V _{OUT} +0.5V ≤ V _{IN} ≤ 6.0V I _{OUT} =30mA, V _{ECO} =GND If V _{OUT} ≤ 1.6V, then 2.2V ≤ V _{IN} ≤ 6.0V		0.02	0.10	%V
		LP Mode	Set V _{OUT} +0.5V ≤ V _{IN} ≤ 6.0V I _{OUT} =30mA, V _{ECO} =V _{IN} If V _{OUT} ≤ 1.6V, then 2.2V ≤ V _{IN} ≤ 6.0V		0.05	0.20	
RR	Ripple Rejection (FT Mode)	Ripple 0.2V _{p-p} V _{IN} =Set V _{OUT} +1V, I _{OUT} =30mA, V _{ECO} =GND If V _{OUT} ≤ 1.7V, then V _{IN} =Set V _{OUT} +1.2V	f = 1kHz		70		dB
			f = 10kHz		60		
V _{IN}	Input Voltage		2.0		6.0	V	
ΔV _{OUT} / ΔT _{opt}	Output Voltage Temperature Coefficient	I _{OUT} = 30mA -40°C ≤ T _{opt} ≤ 85°C		±100		ppm/°C	
I _{SC}	Short Current Limit	V _{OUT} = 0V		40		mA	
I _{PD}	CE Pull-down Current			0.3	0.6	μA	
V _{CEH}	CE, \overline{ECO} Input Voltage "H"		1.0		6.0	V	
V _{CEL}	CE, \overline{ECO} Input Voltage "L"		0		0.4	V	
en	Output Noise "H" (FT Mode)	BW = 10Hz to 100kHz		30		μV _{rms}	
	Output Noise "L" (LP Mode)	BW = 10Hz to 100kHz		40			
I _{REV}	Reverse Current	V _{OUT} >0.5V, 0V ≤ V _{IN} ≤ 6V		0	0.1	μA	

ELECTRICAL CHARACTERISTICS by OUTPUT VOLTAGE

T_{opt}=25°C

Output Voltage V _{OUT} (V)	Dropout Voltage (mV)				
	Condition	V _{DIF} (FT Mode)		V _{DIF} (LP Mode)	
		Typ.	Max.	Typ.	Max.
1.5 ≤ V _{OUT} < 1.6	I _{OUT} =150mA	400	680	420	680
1.6 ≤ V _{OUT} < 1.7		380	550	390	550
1.7 ≤ V _{OUT} < 1.8		350	520	370	520
1.8 ≤ V _{OUT} < 2.0		340	490	350	490
2.0 ≤ V _{OUT} < 2.8		290	425	300	430
2.8 ≤ V _{OUT} ≤ 5.0		250	350	250	350

TYPICAL APPLICATION

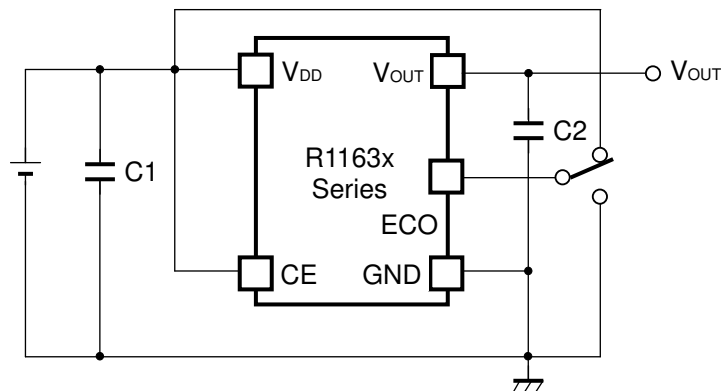

(External Components)

Ex. C1: Ceramic Capacitor 1.0μF

C2: Ceramic Capacitor 0.47μF Murata GRM40B474K

Kyocera CM105B474K

TECHNICAL NOTES

When using these ICs, consider the following points:

Phase Compensation

In these ICs, phase compensation is made for securing stable operation even if the load current is varied. For this purpose, be sure to use a 0.47μF or more ceramic capacitor C2.

(Test these ICs with as same external components as ones to be used on the PCB.)

When a tantalum capacitor is used with this IC, if the equivalent series resistor (ESR) of the capacitor is large, output voltage may be unstable.

PCB Layout

Make V_{DD} and GND lines sufficient. If their impedance is high, noise pickup or unstable operation may result. Connect a capacitor C1 with as much as 1.0μF capacitor between V_{DD} and GND pin as close as possible.

Set external components such as an output capacitor C2, as close as possible to the ICs and make wiring as short as possible.

TEST CIRCUITS

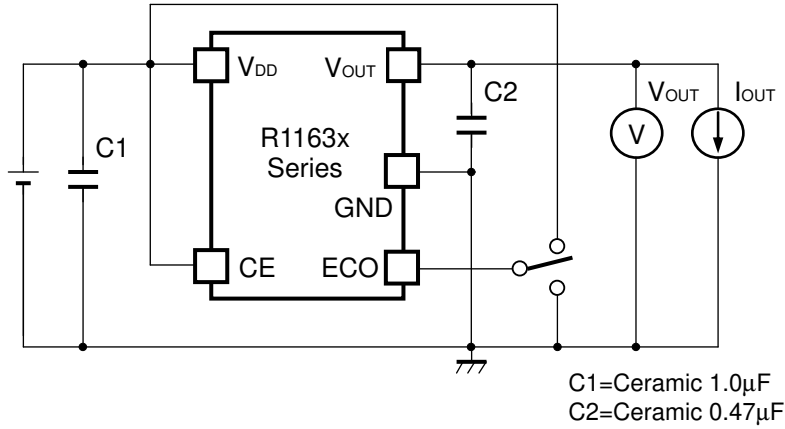

Basic Test Circuit

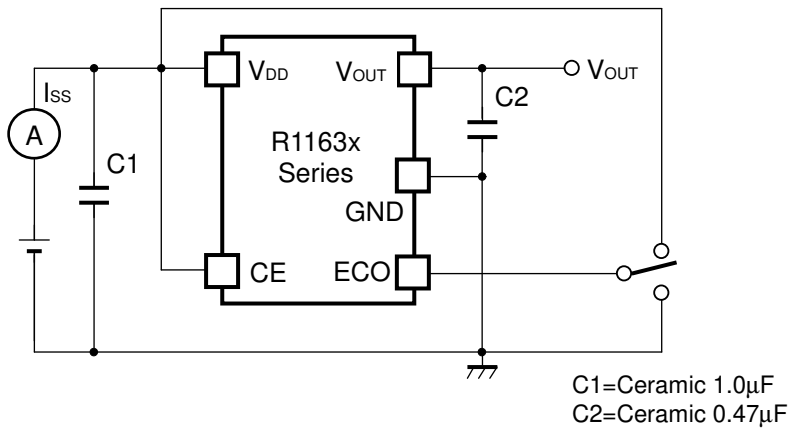

Test Circuit for Supply Current

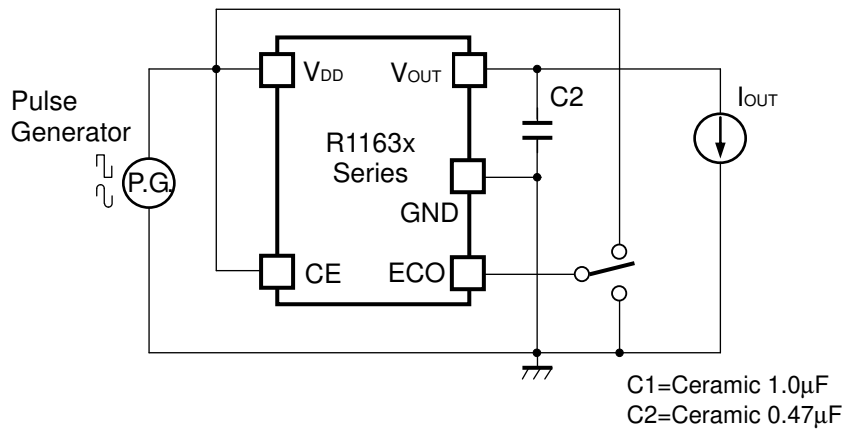

Test Circuit for Ripple Rejection, Line Transient Response

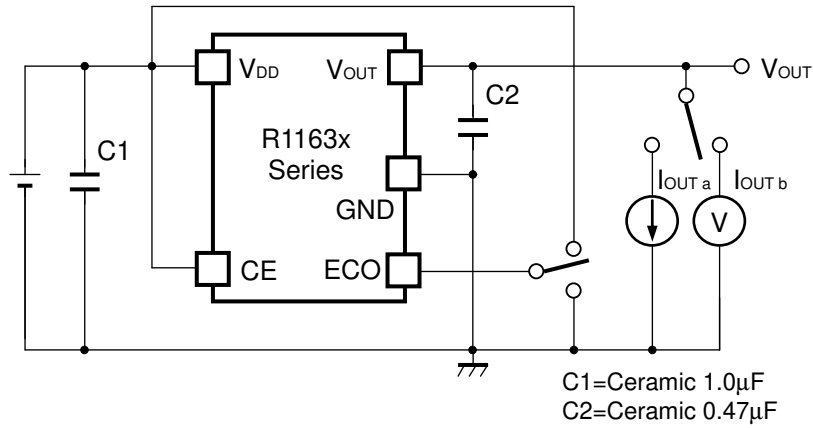

Test Circuit for Load Transient Response

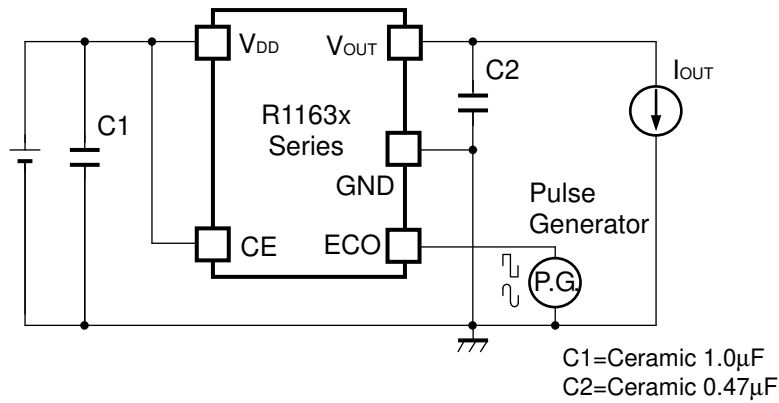

Test Circuit for Output Voltage at Mode alternative point

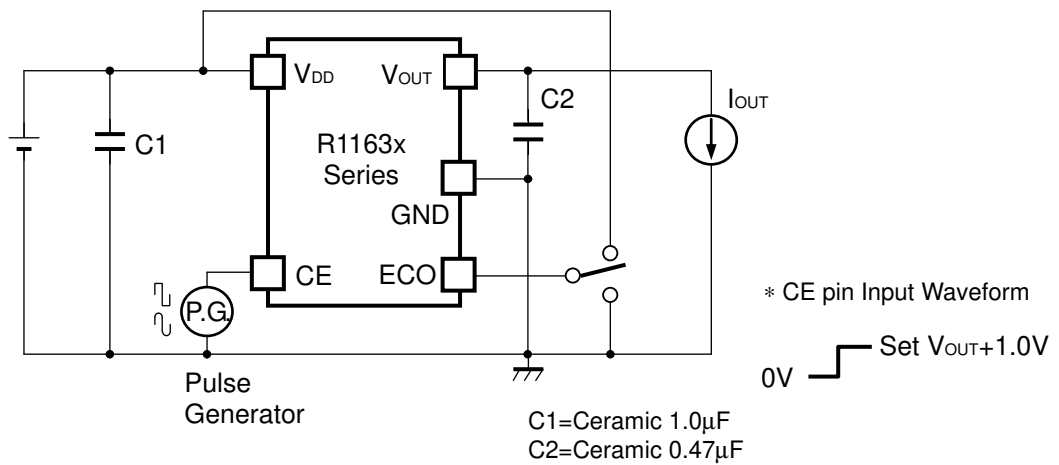

Test Circuit for Turn On Speed with CE pin

TYPICAL CHARACTERISTICS

Unless otherwise provided, capacitors are ceramic type.

1) Output Voltage vs. Output Current

R1163x151x FT Mode

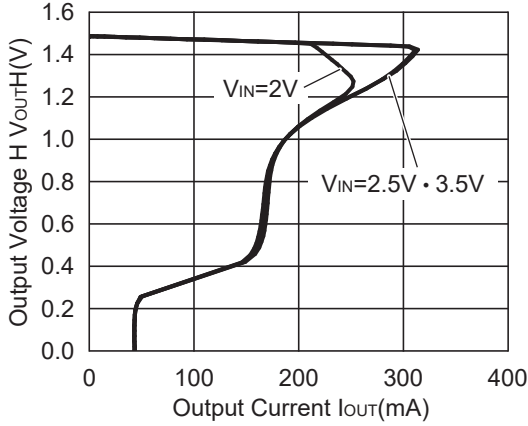

R1163x151x LP Mode

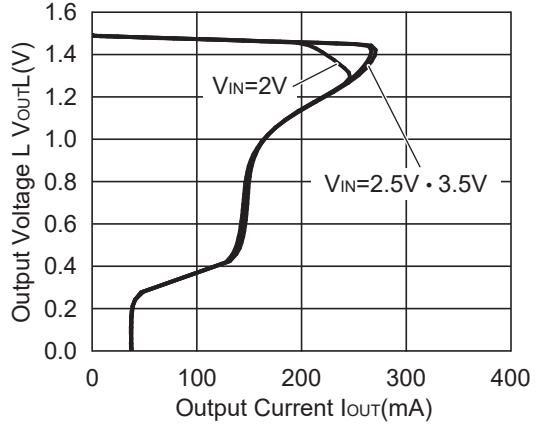

R1163x281x FT Mode

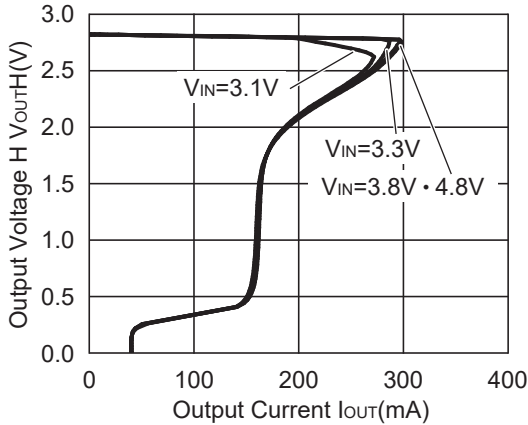

R1163x281x LP Mode

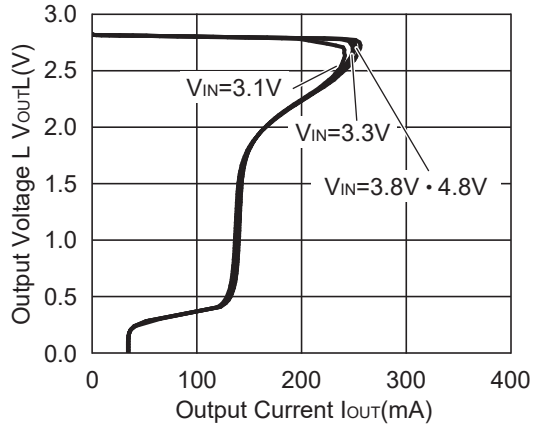

R1163x40x FT Mode

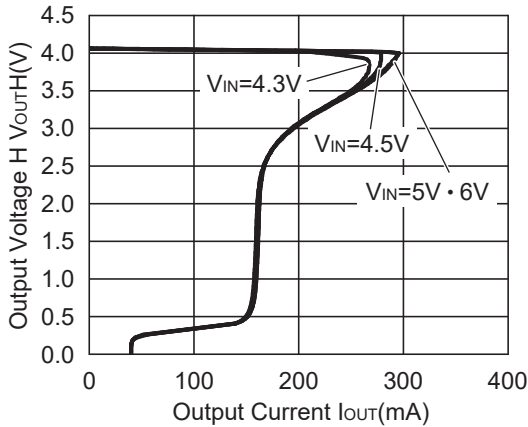

R1163x40x LP Mode

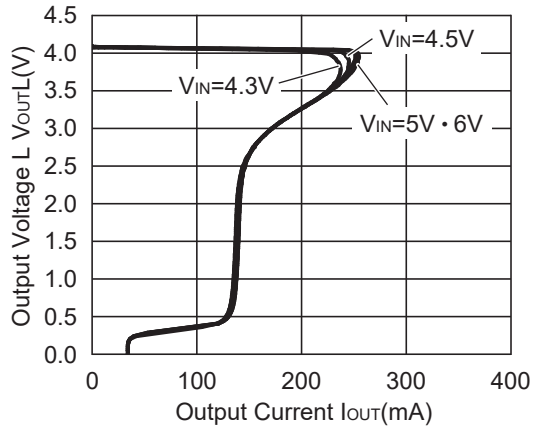

2) Output Voltage vs. Input Voltage

R1163x151x FT Mode

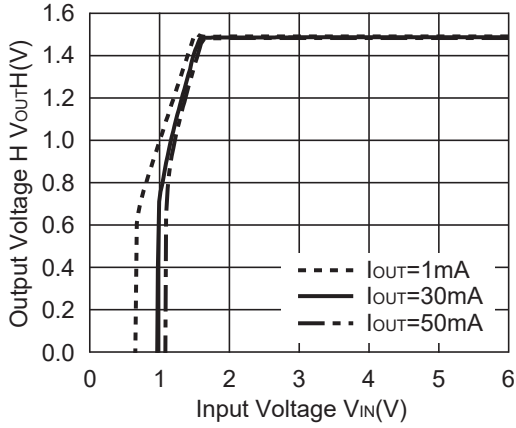

R1163x15x LP Mode

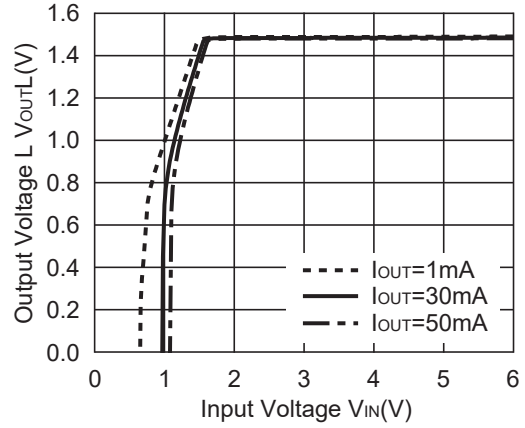

R1163x28x FT Mode

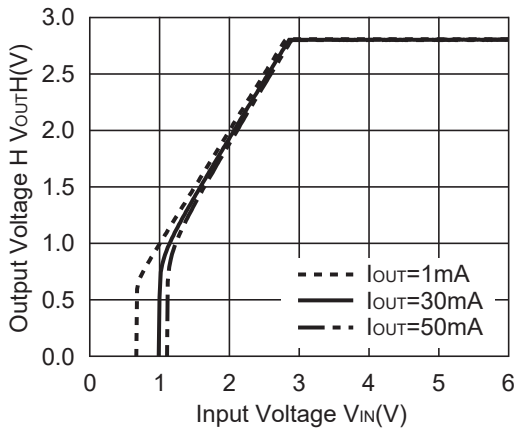

R1163x28x LP Mode

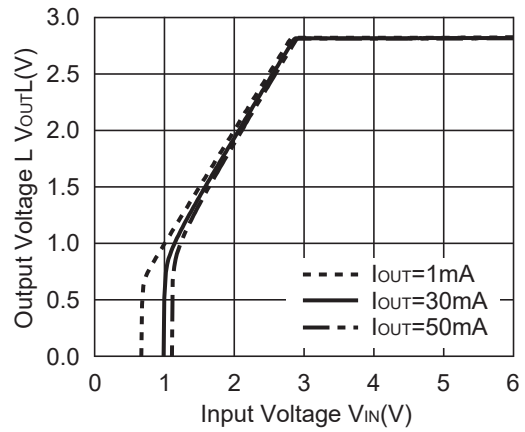

R1163x40x FT Mode

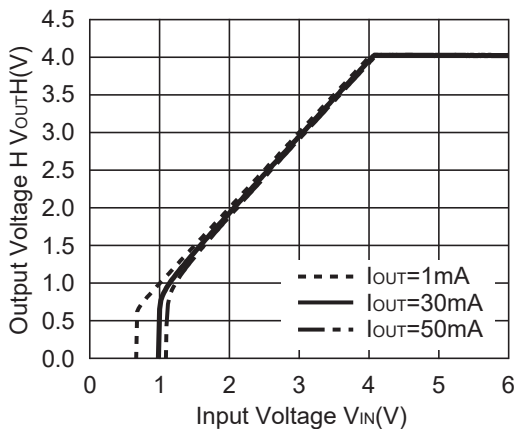

R1163x40x LP Mode

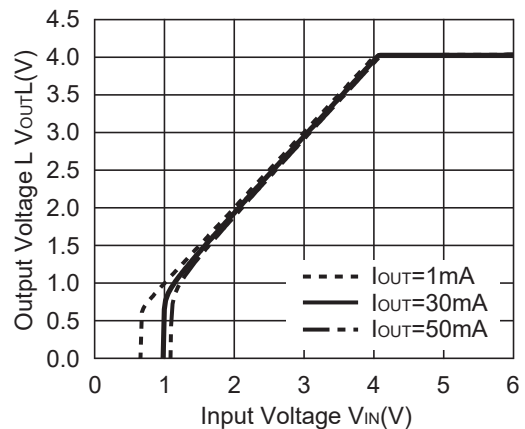

3) Supply Current vs. Input Voltage

R1163x151x FT Mode

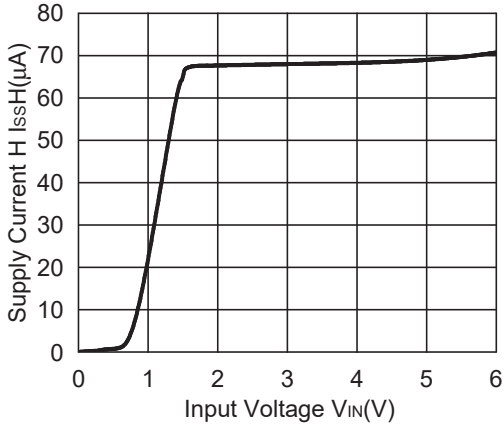

R1163x151x LP Mode

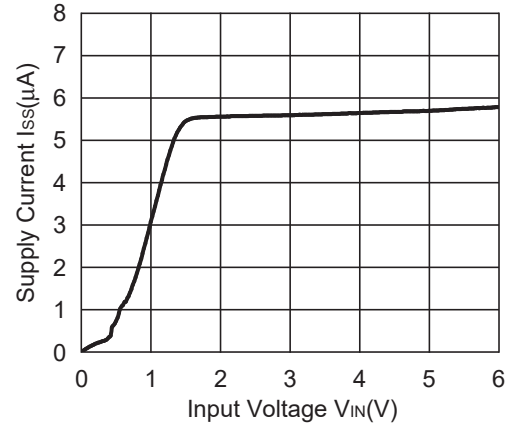

R1163x281x FT Mode

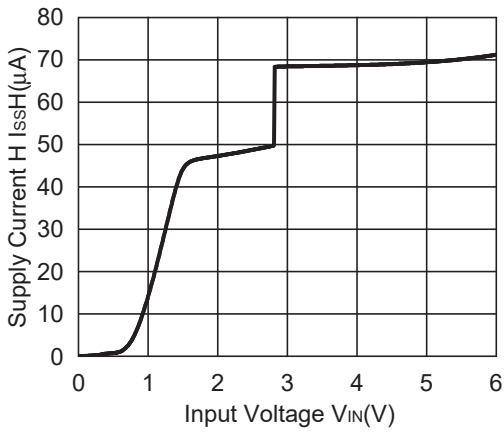

R1163x281x LP Mode

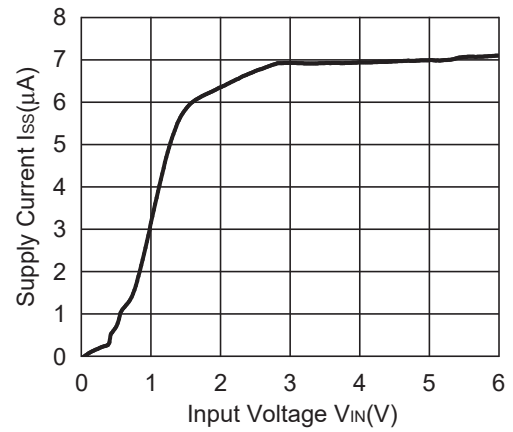

R1163x401x FT Mode

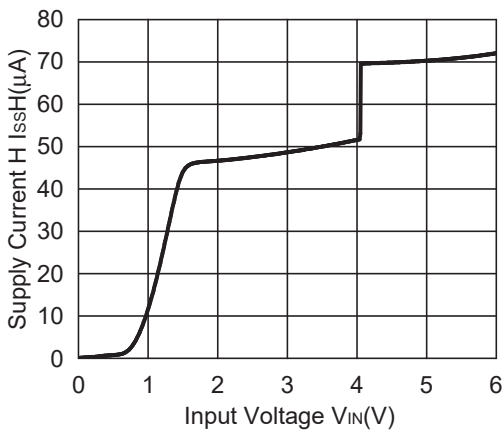

R1163x401x LP Mode

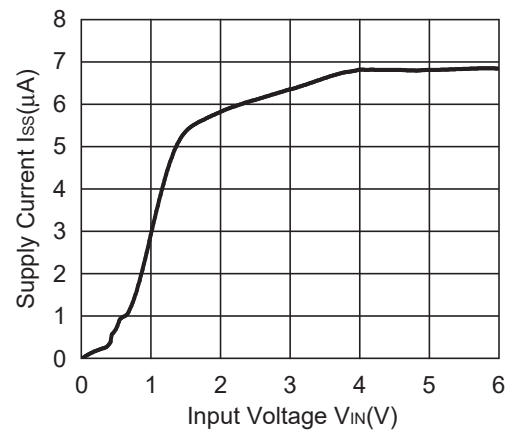

4) Output Voltage vs. Temperature

R1163x151x FT Mode

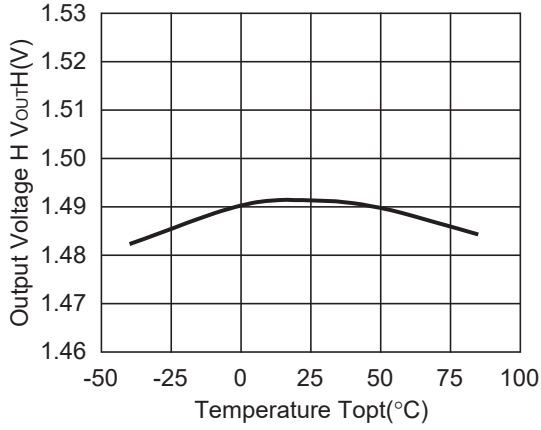

R1163x151x LP Mode

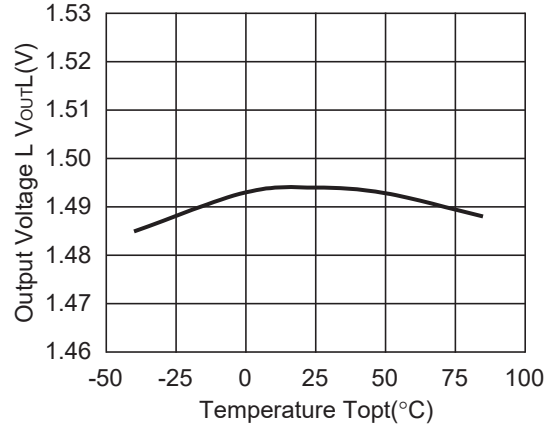

R1163x281x FT Mode

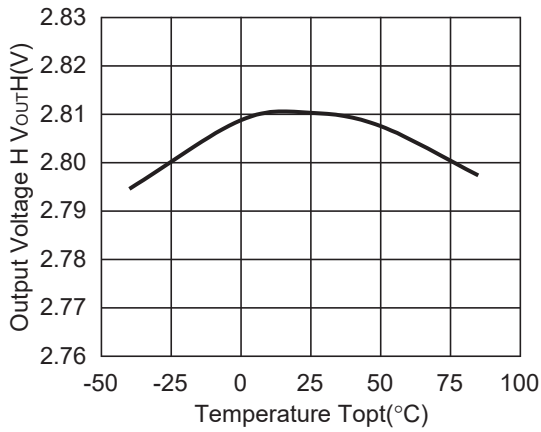

R1163x281x LP Mode

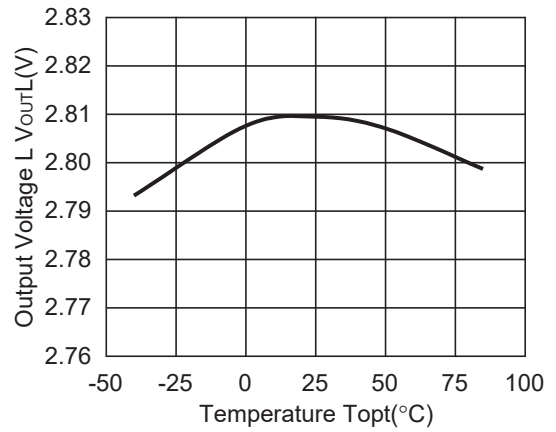

R1163x401x FT Mode

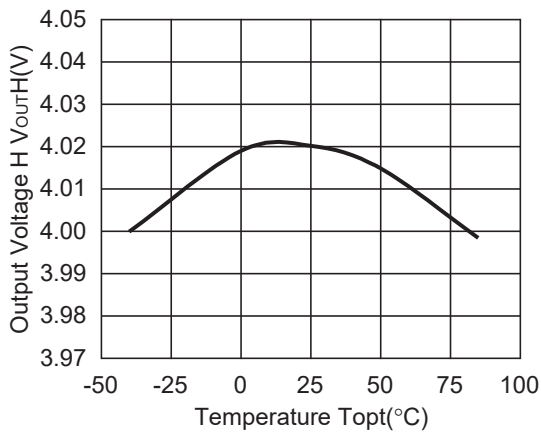

R1163x401x LP Mode

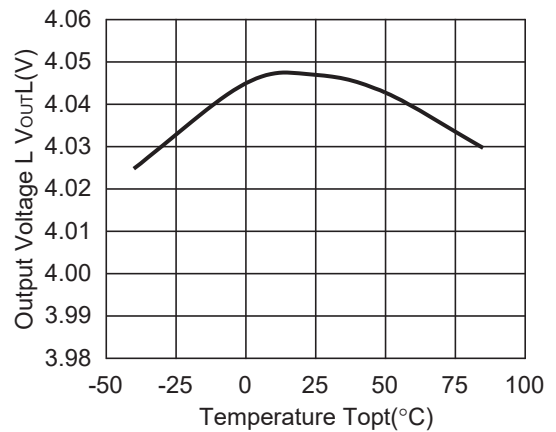

5) Supply Current vs. Temperature

R1163x151x FT Mode

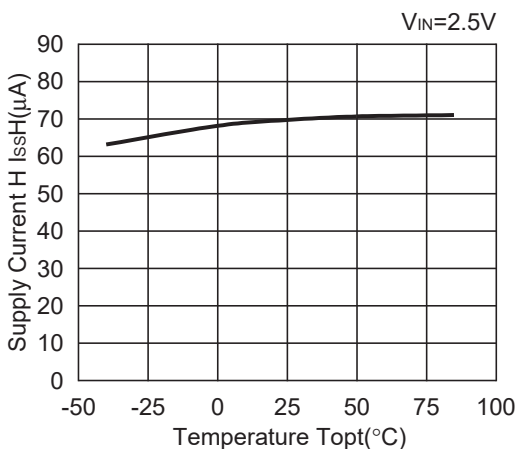

R1163x151x LP Mode

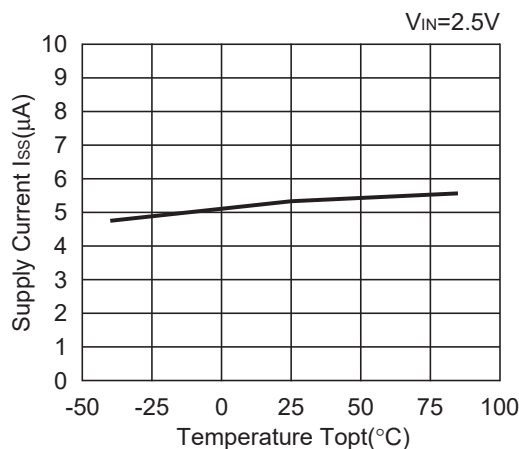

R1163x281x FT Mode

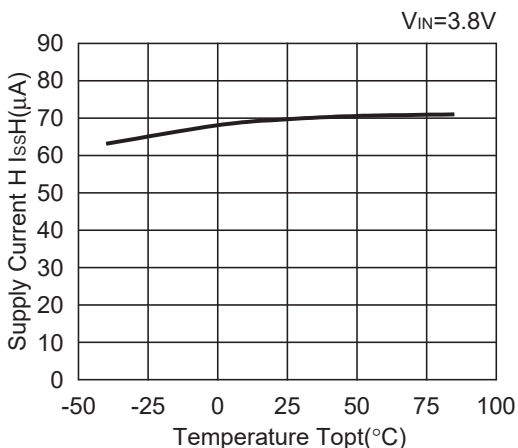

R1163x281x LP Mode

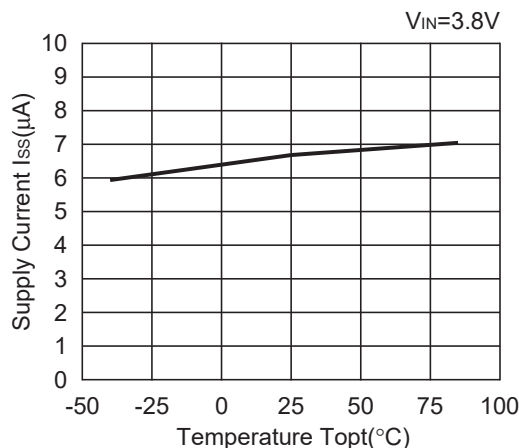

R1163x401x FT Mode

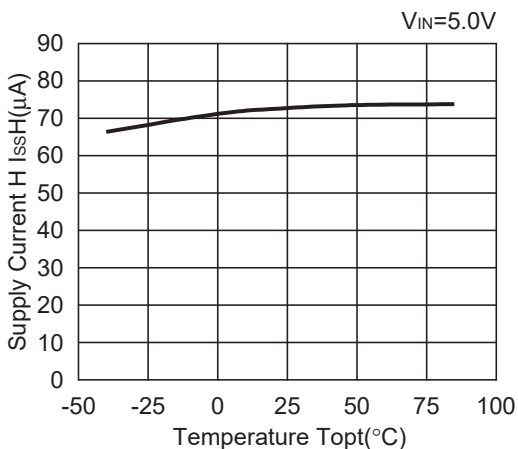

R1163x401x LP Mode

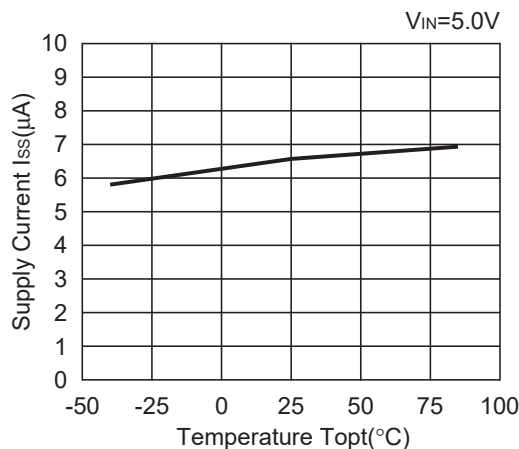

6) Standby Current vs. Input Voltage

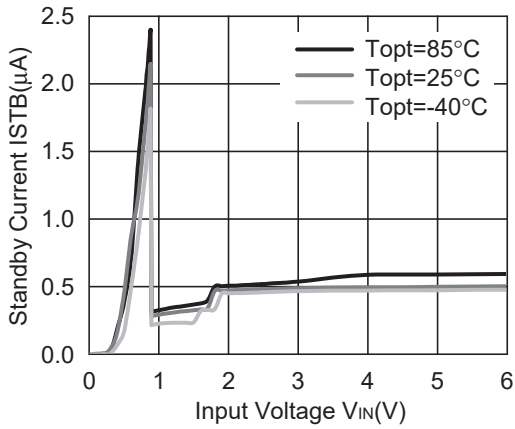

7) Reverse Current vs. Output Voltage

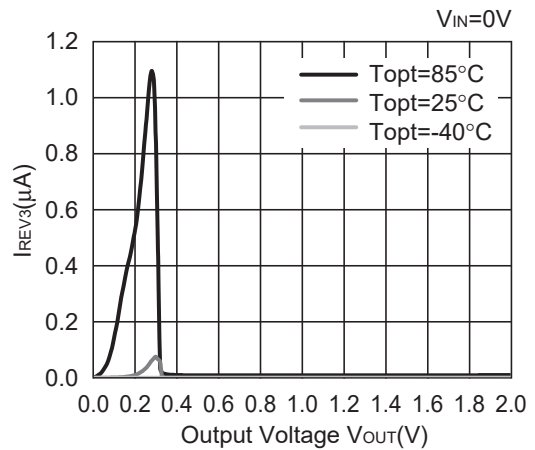
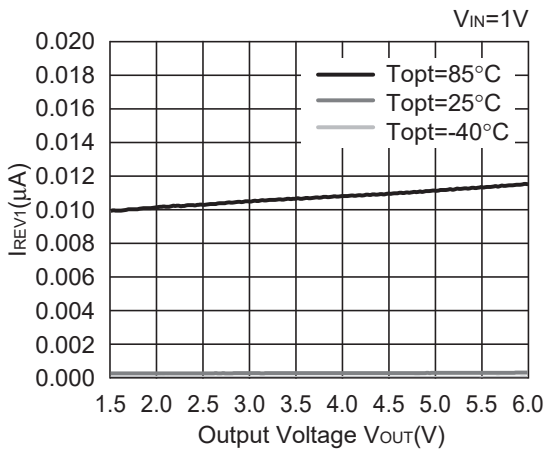

8) Dropout Voltage vs. Output Current

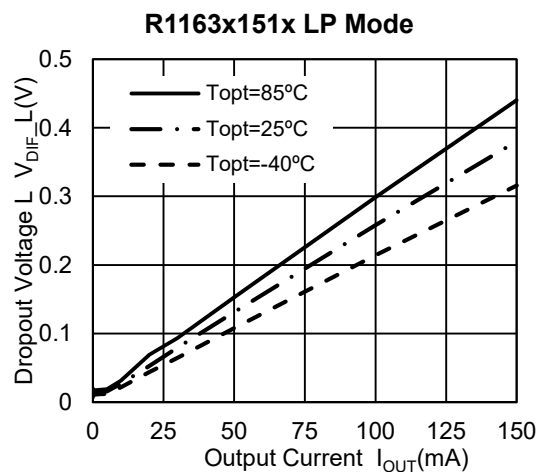
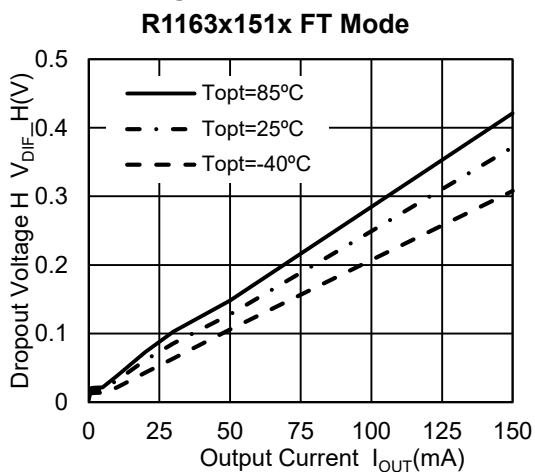

R1163x161x FT Mode

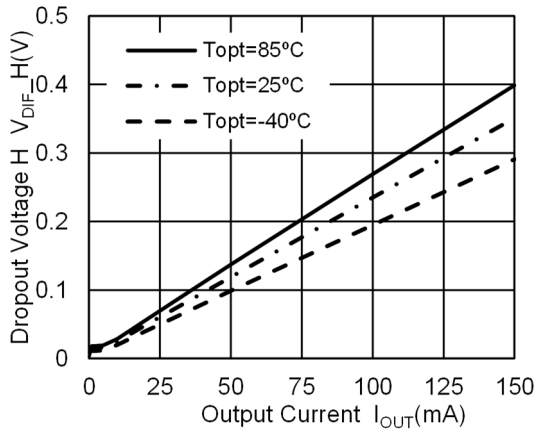

R1163x161x LP Mode

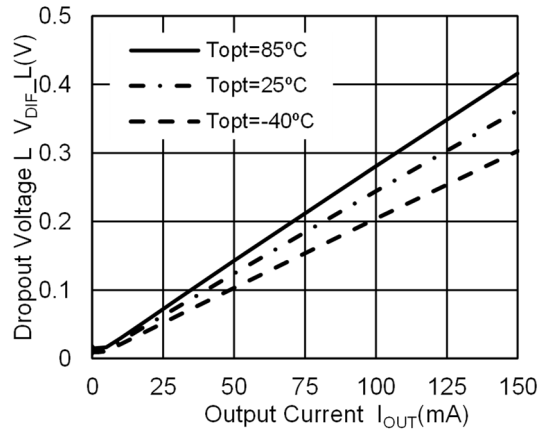

R1163x171x FT Mode

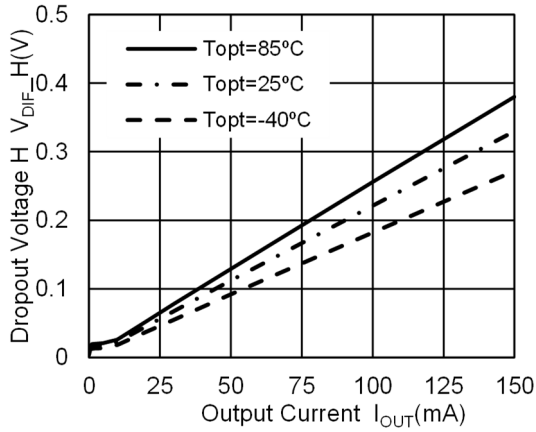

R1163x171x LP Mode

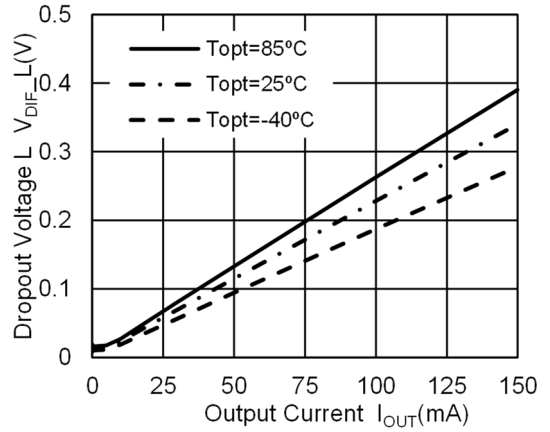

R1163x181x FT Mode

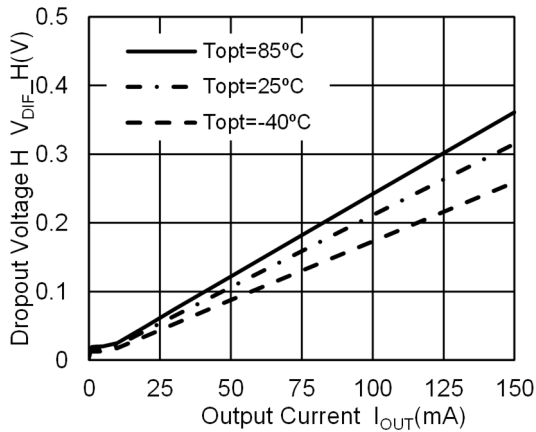

R1163x181x LP Mode

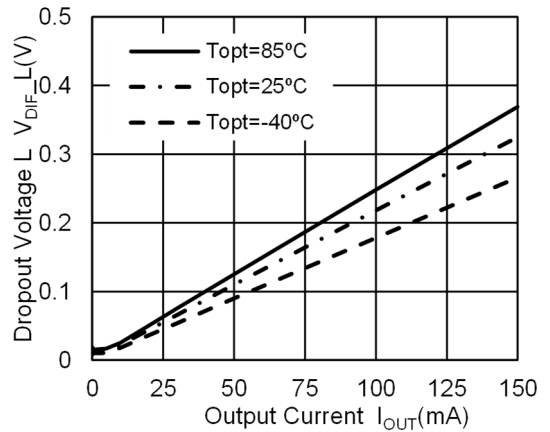

R1163x211x FT Mode

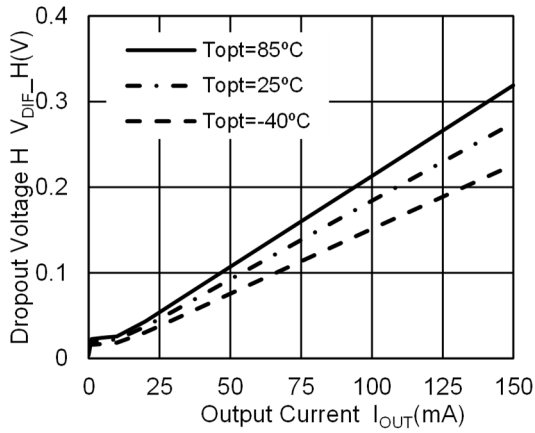

R1163x211x LP Mode

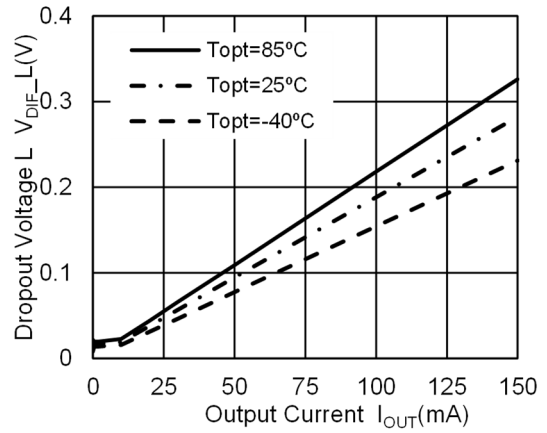

R1163x281x FT Mode

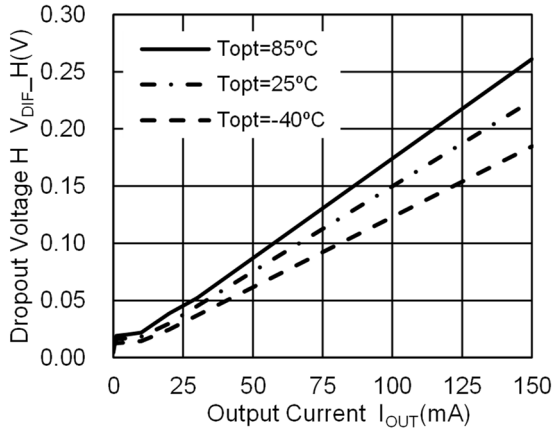

R1163x281x LP Mode

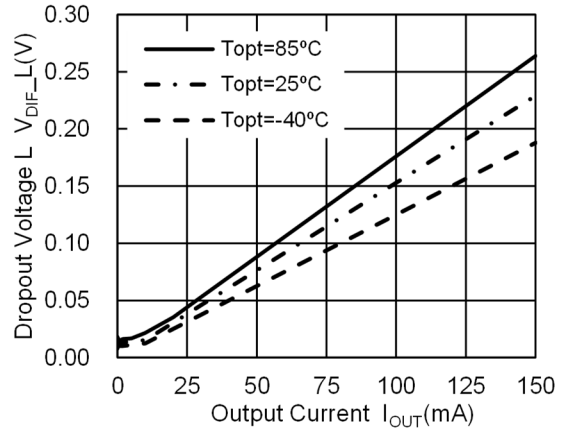

R1163x401x FT Mode

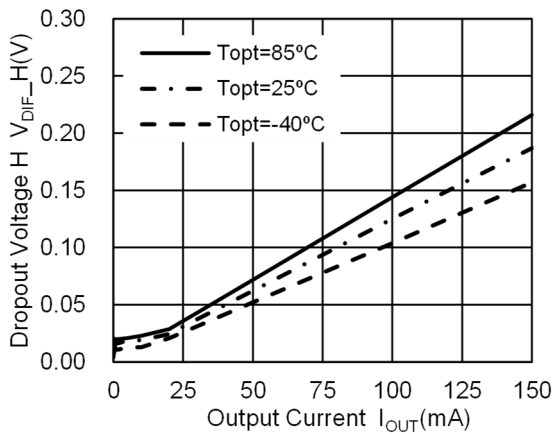

R1163x401x LP Mode

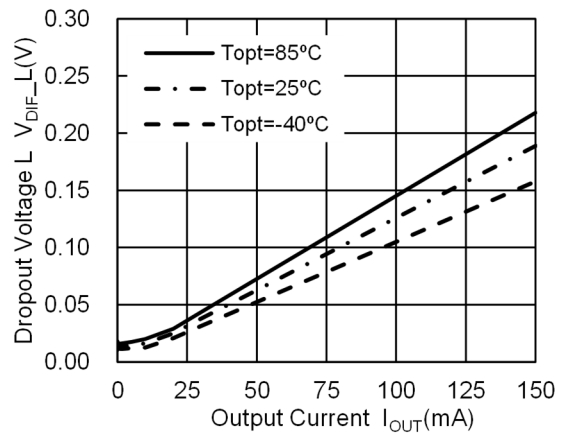

9) Dropout Voltage vs. Set Output Voltage

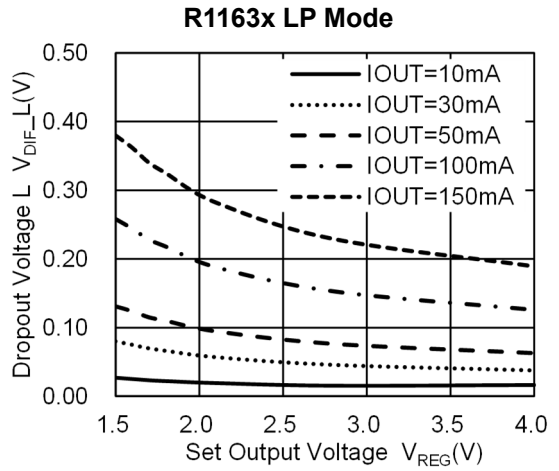
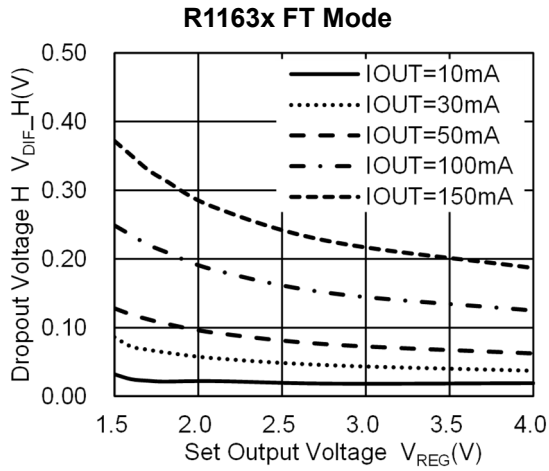

10) Ripple Rejection vs. Input Bias Voltage

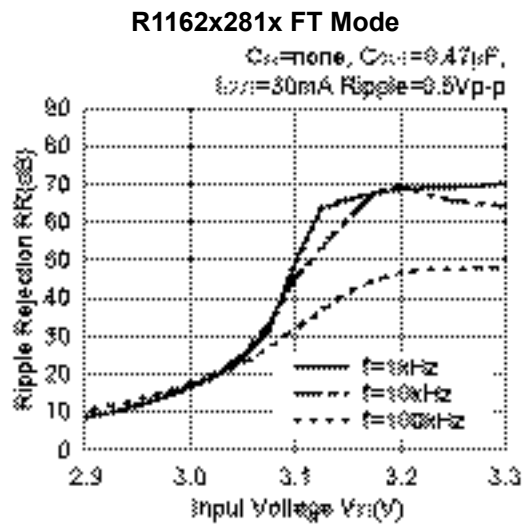
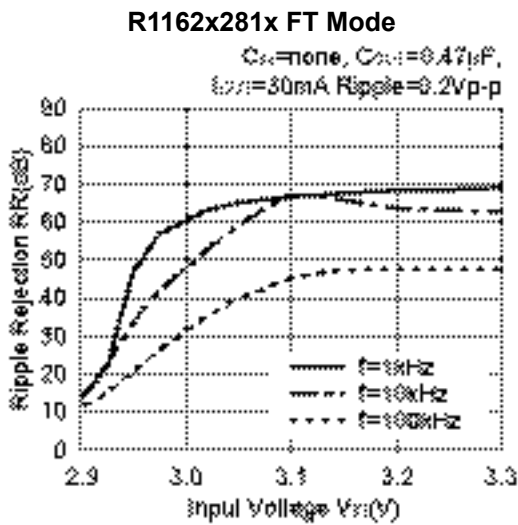
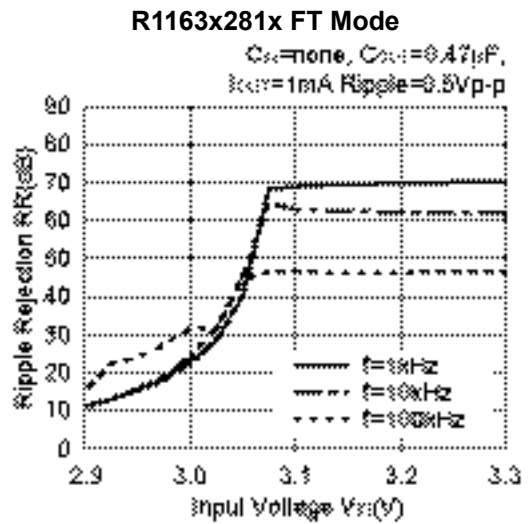
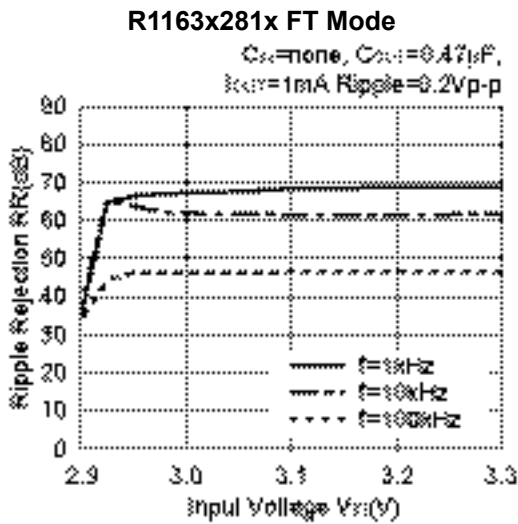

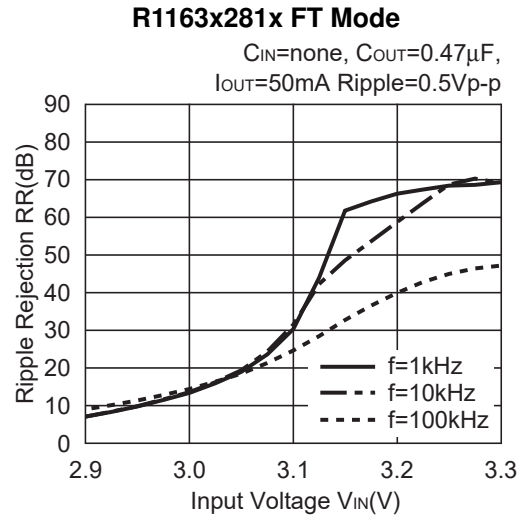
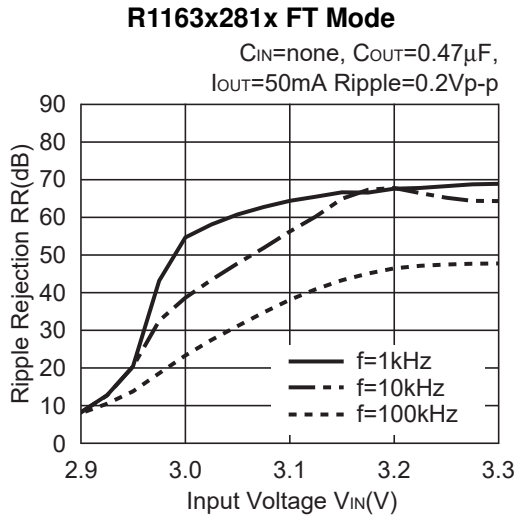

11) Ripple Rejection vs. Frequency

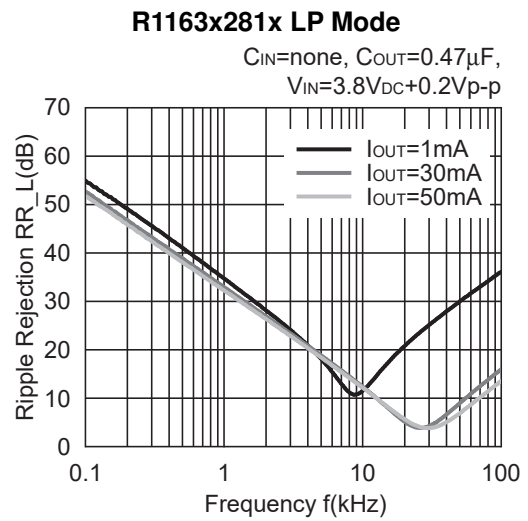
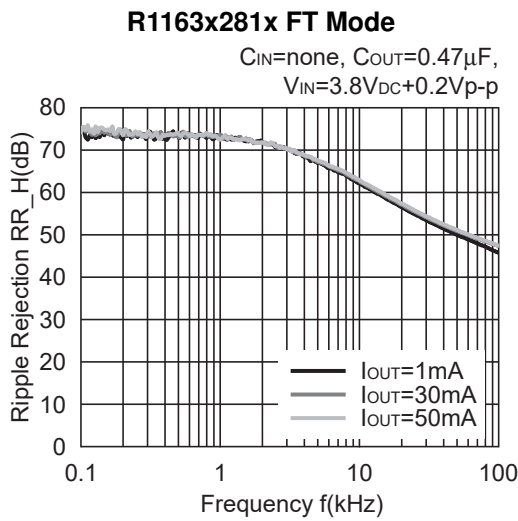
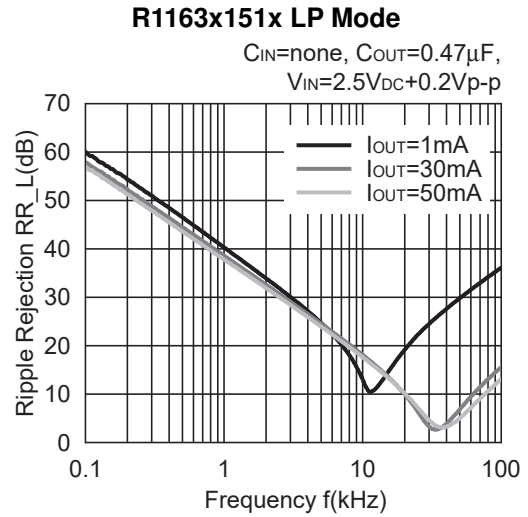
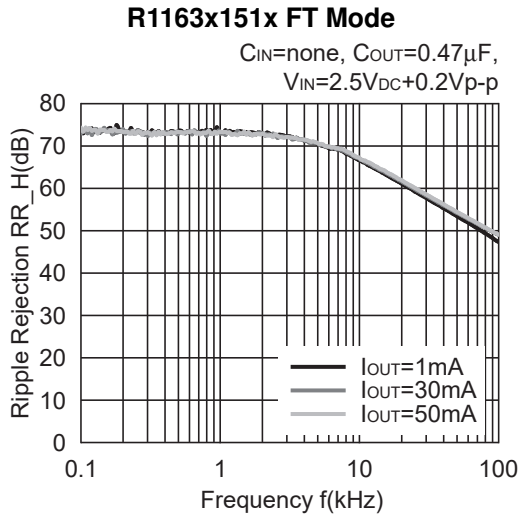

R1163x401x FT Mode

C_{IN} =none, C_{OUT} =0.47 μ F,
 V_{IN} =5.0V_{DC}+0.2V_{p-p}

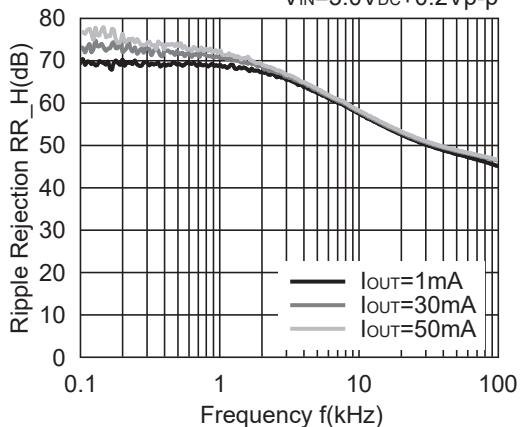

R1163x401x LP Mode

C_{IN} =none, C_{OUT} =0.47 μ F,
 V_{IN} =5.0V_{DC}+0.2V_{p-p}

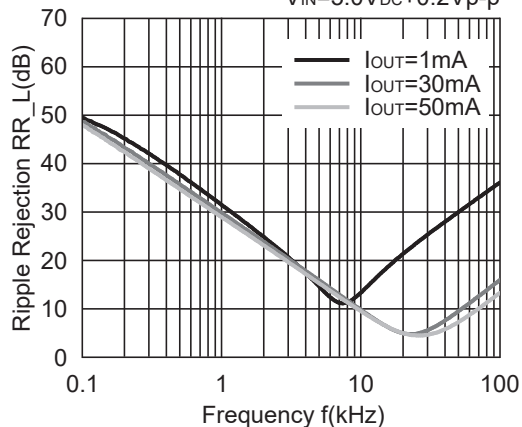

12) Input Transient Response

R1163x151x FT Mode

C_{IN} =none, C_{OUT} =0.47 μ F I_{OUT} =30mA

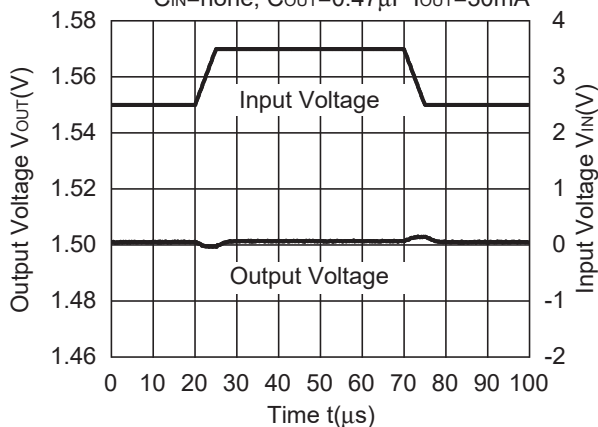

R1163x151x LP Mode

C_{IN} =none, C_{OUT} =0.47 μ F I_{OUT} =10mA

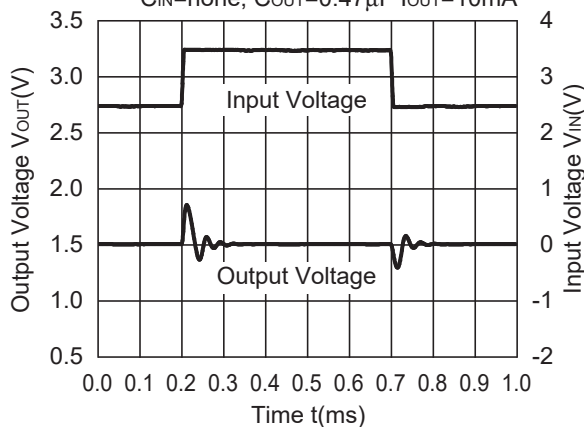

R1163x151x LP Mode

C_{IN} =none, C_{OUT} =1 μ F I_{OUT} =10mA

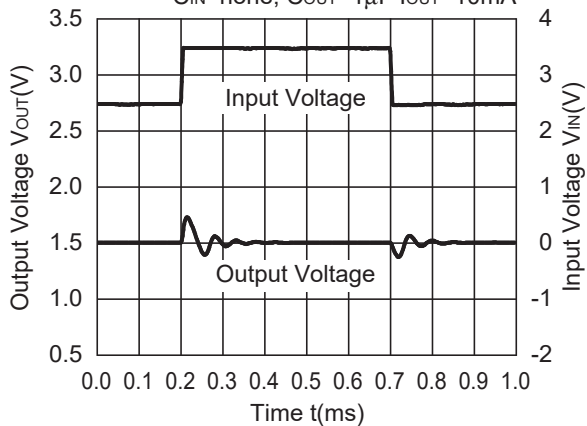

R1163x281x FT Mode

C_{IN} =none, C_{OUT} =1 μ F I_{OUT} =30mA

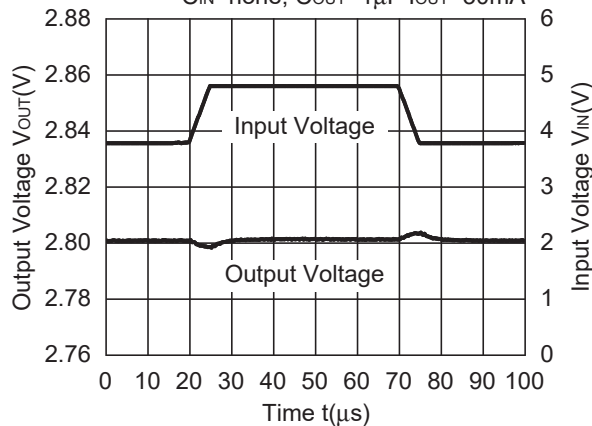

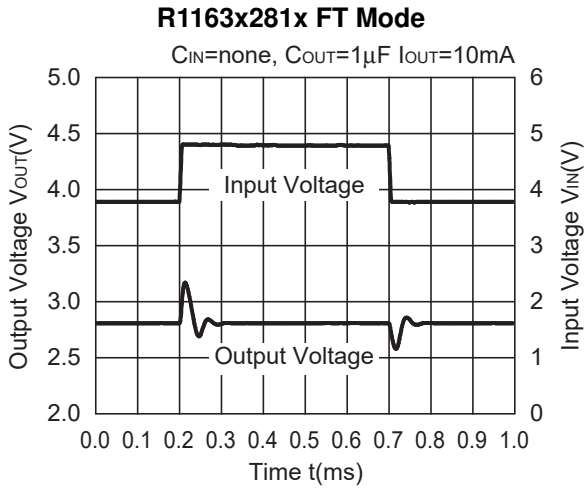

13) Load Transient Response

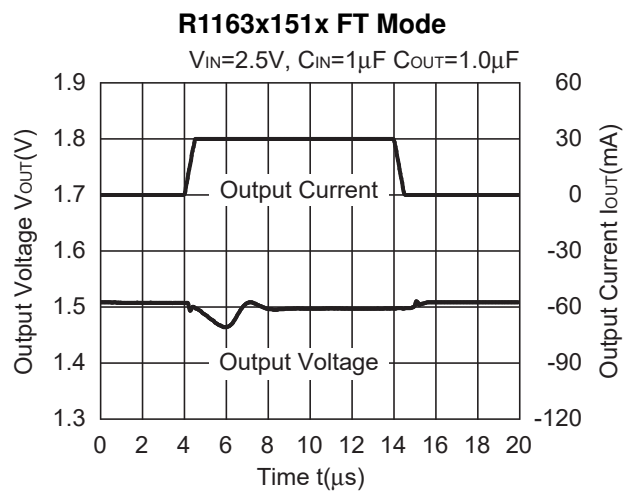
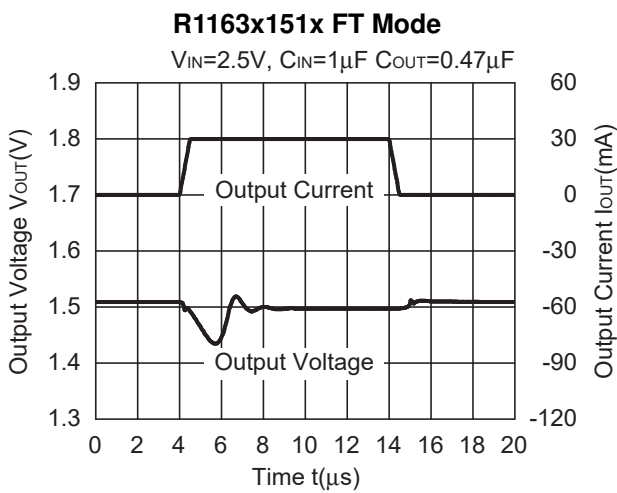
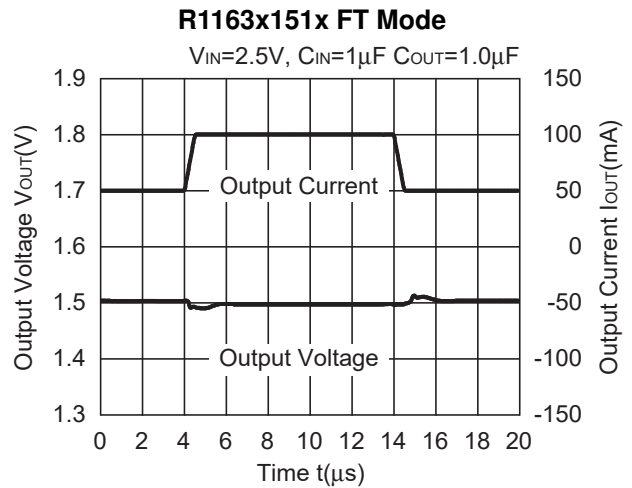
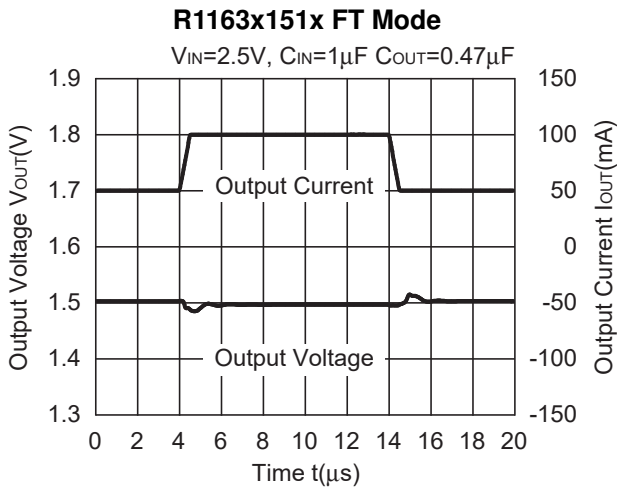

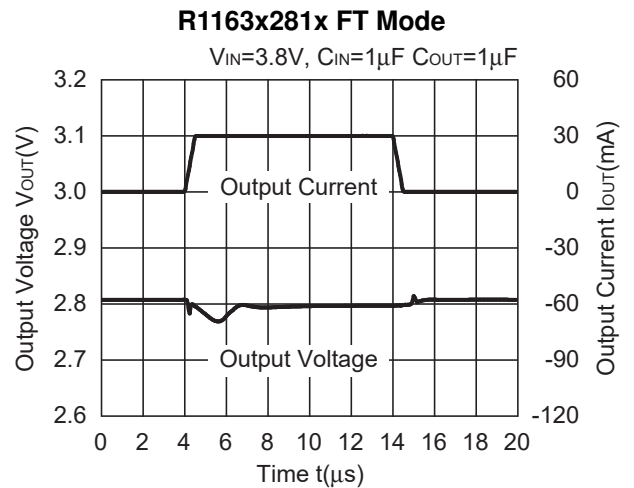
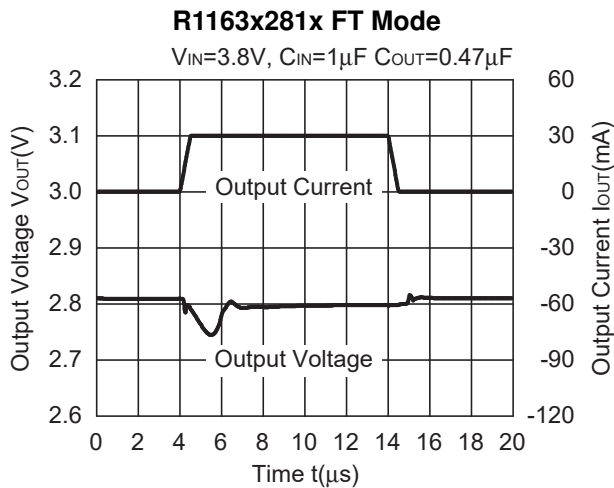
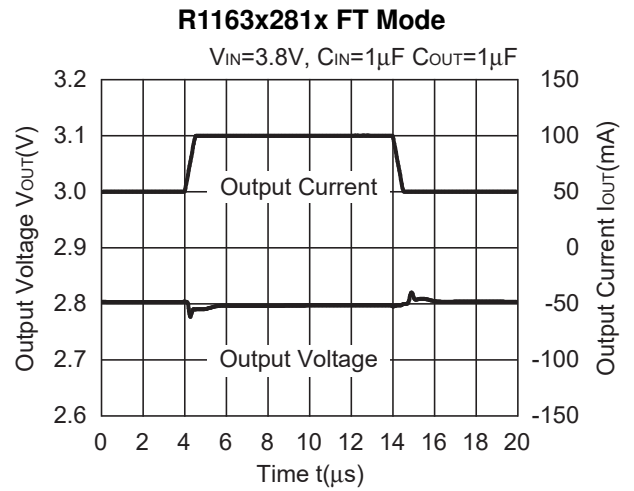
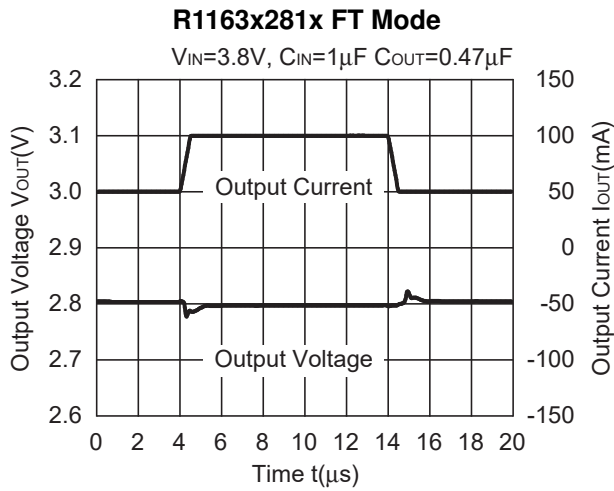
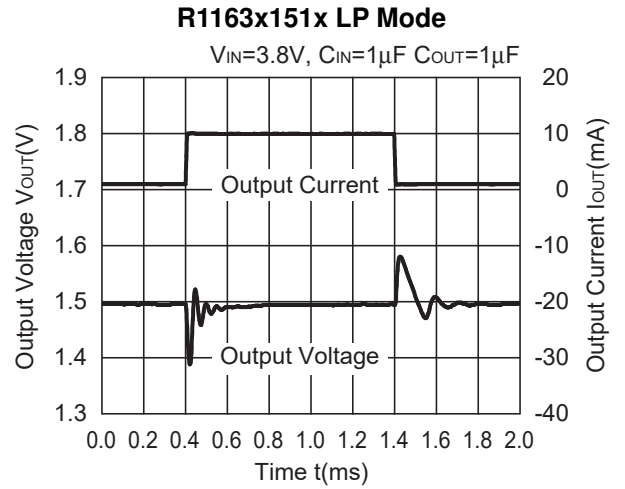
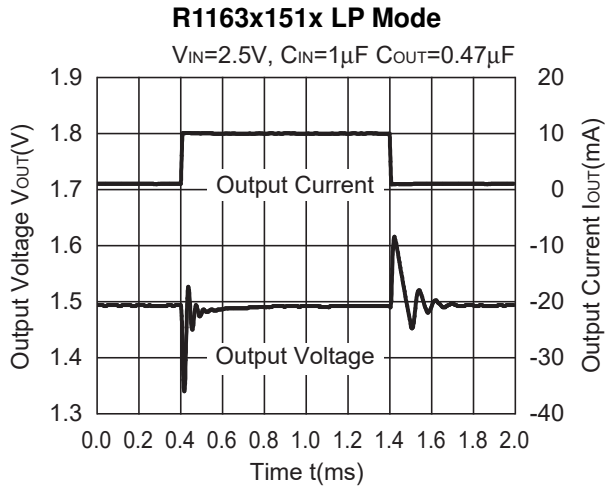

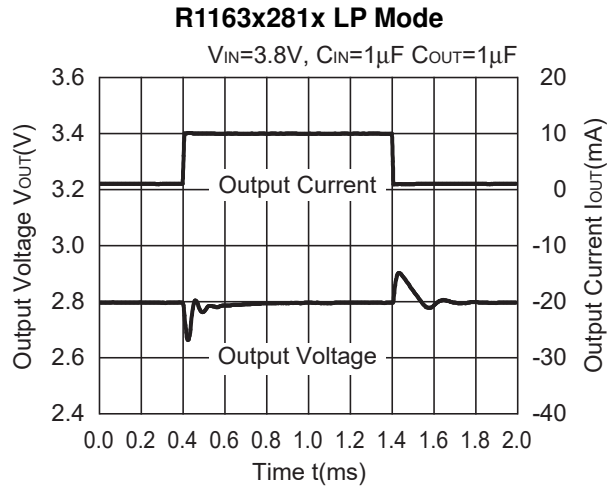
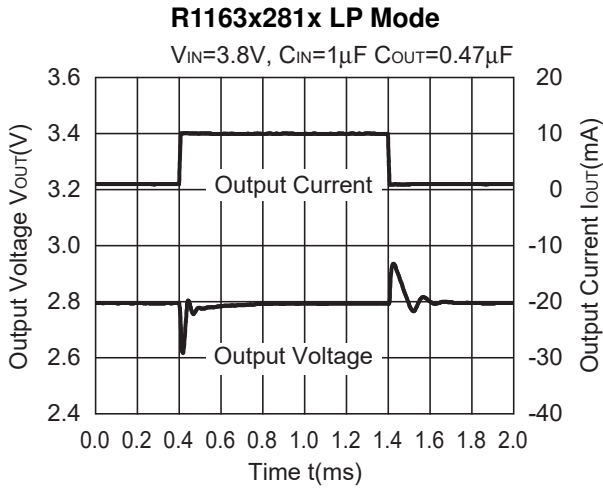

14) Turn on speed with CE pin

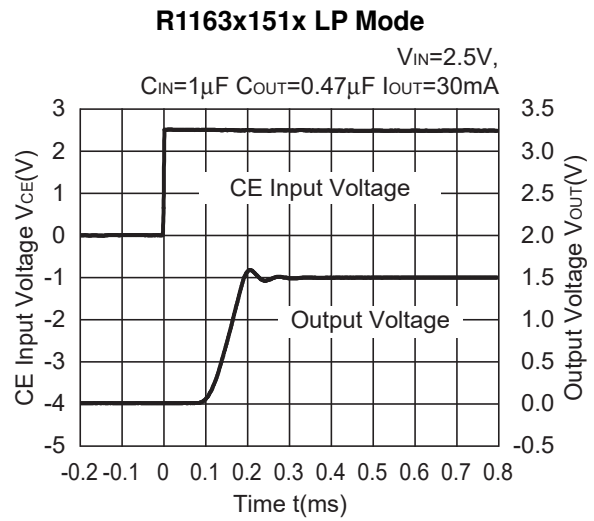
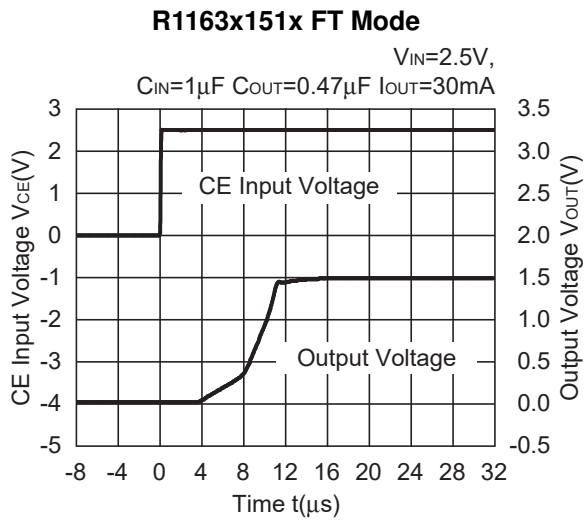
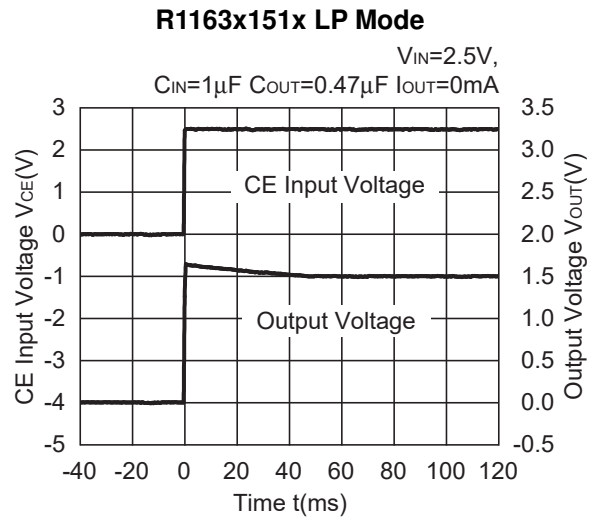
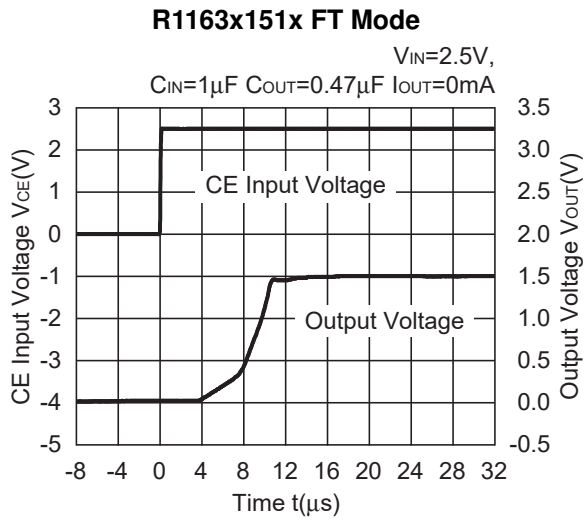

R1163x151x FT Mode

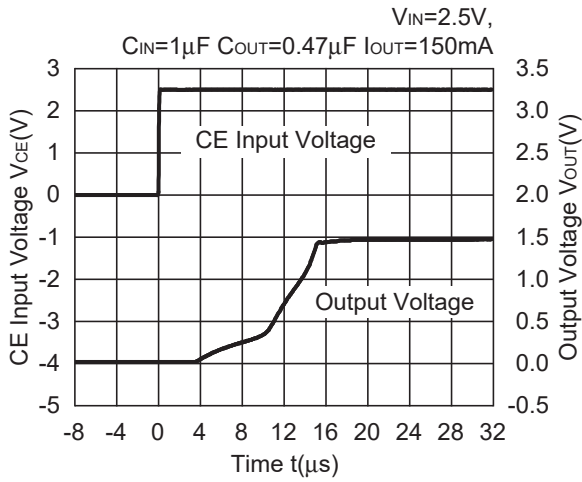

R1163x151x LP Mode

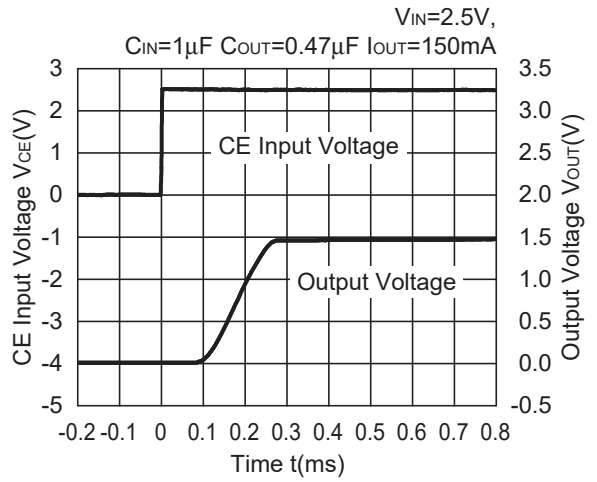

R1163x281x FT Mode

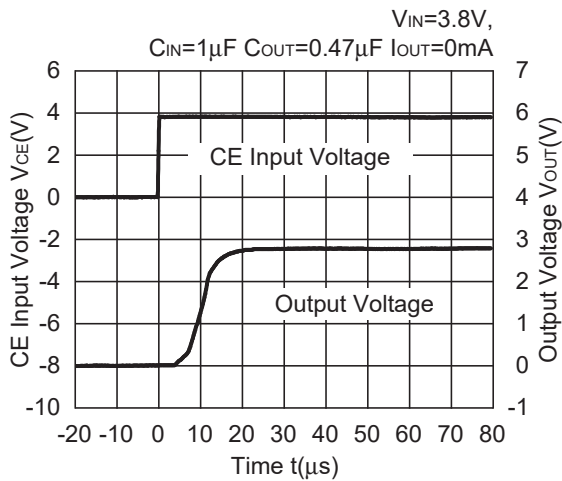

R1163x281x LP Mode

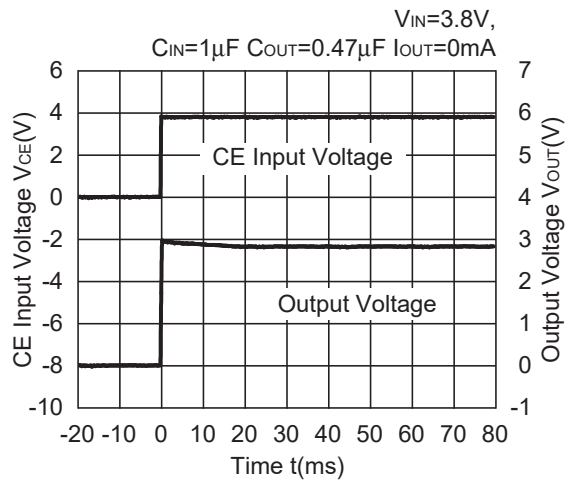

R1163x281x FT Mode

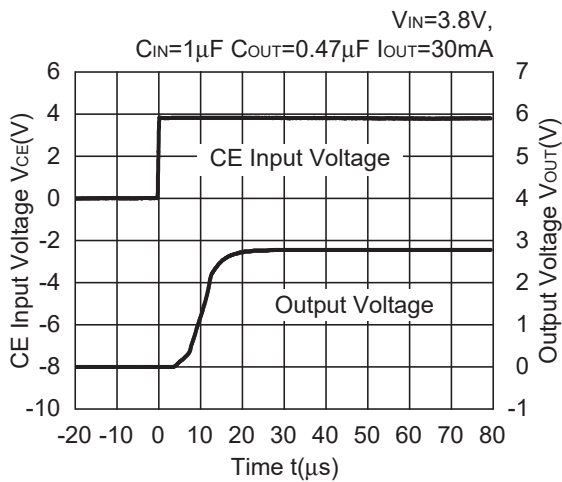

R1163x281x LP Mode

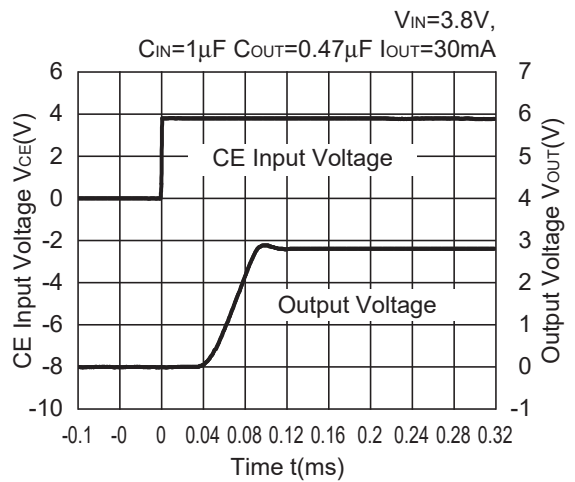

R1163x281x FT Mode

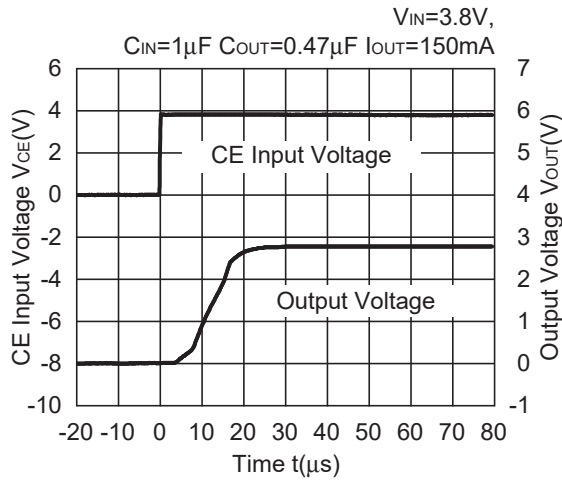

R1163x281x LP Mode

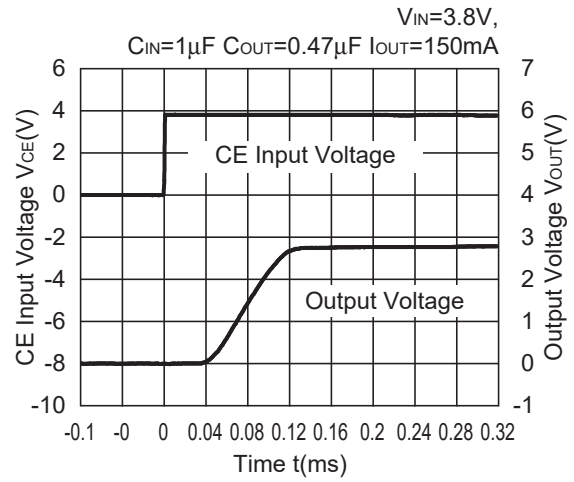

R1163x401x FT Mode

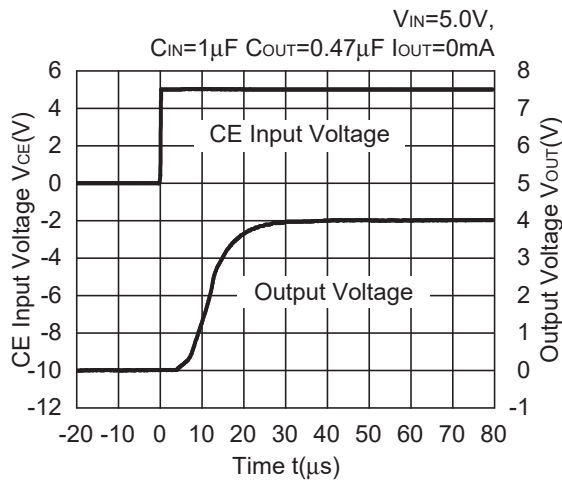

R1163x401x LP Mode

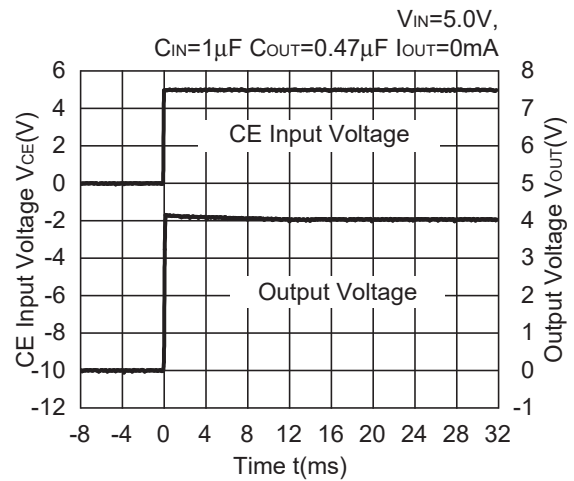

R1163x401x FT Mode

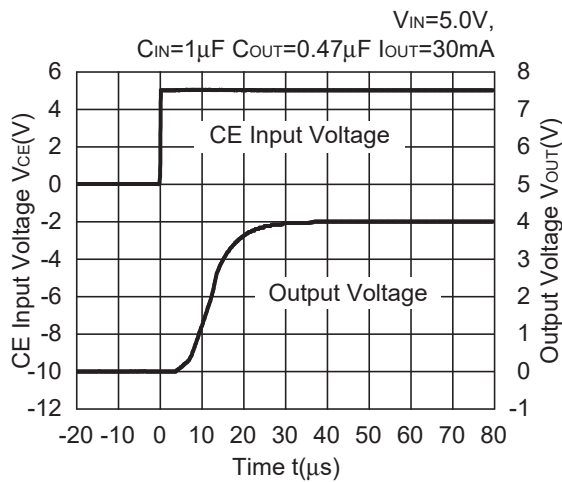

R1163x401x LP Mode

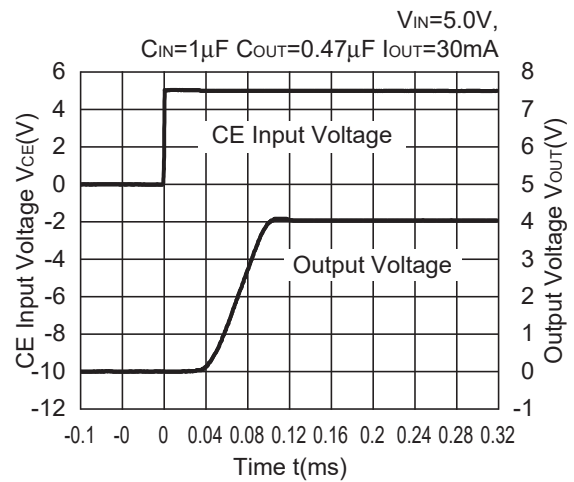

R1163x401x FT Mode

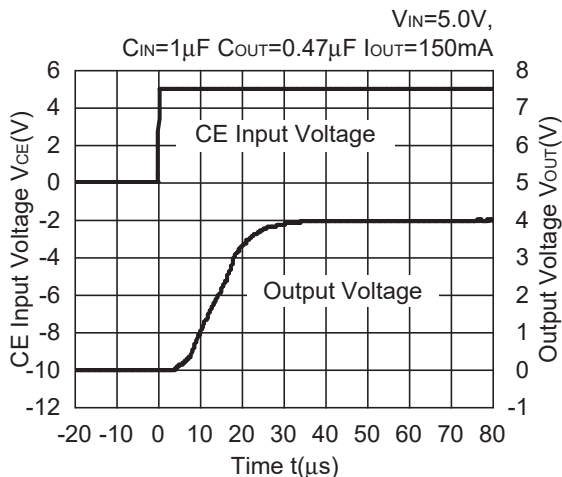

R1163x401x LP Mode

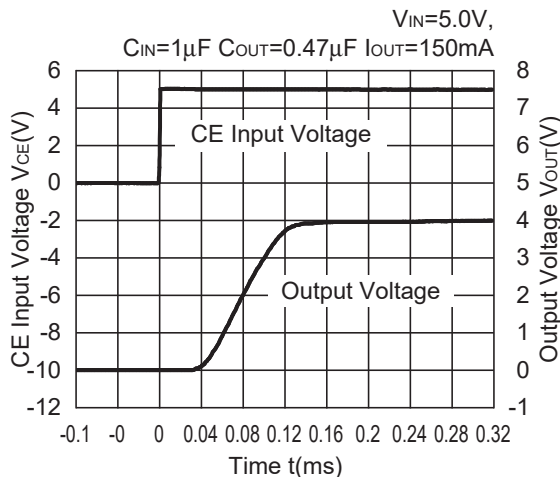

15) Turn off speed with CE pin

R1163x151xD

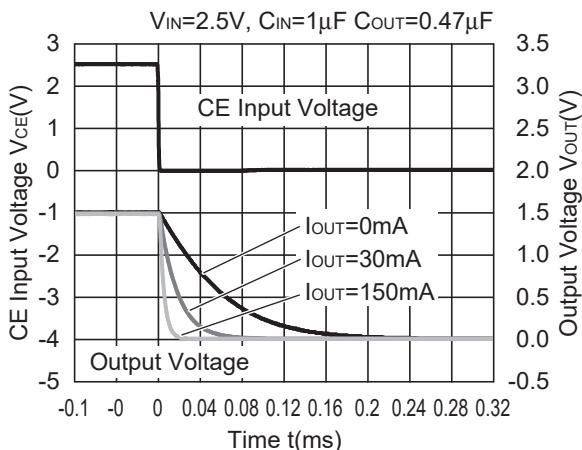

R1163x281xD

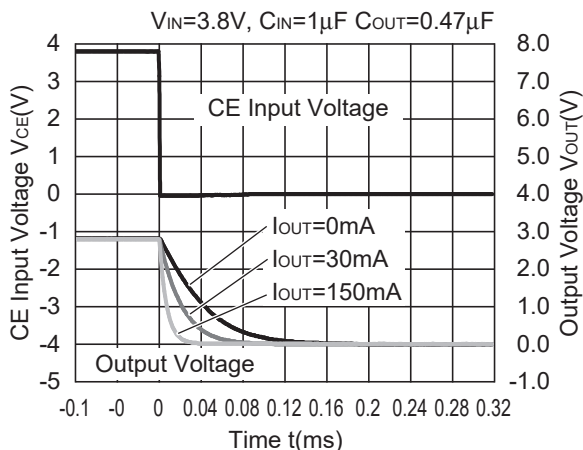

R1163x401xD

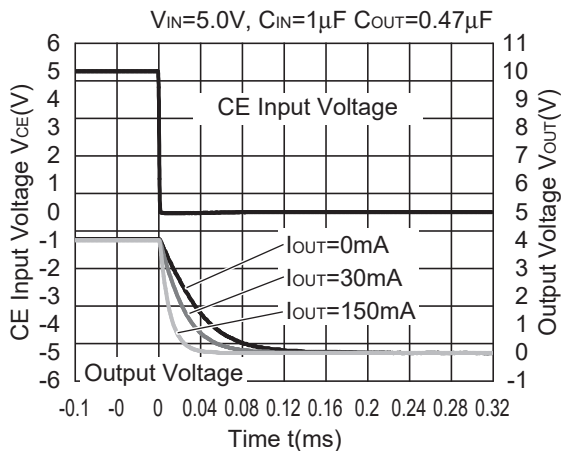

16) Output Voltage at Mode alternative point

R1163x151B/D

$V_{IN}=2.5V$, C_{IN} =Ceramic $1.0\mu F$,
 C_{OUT} =Ceramic $0.47\mu F$

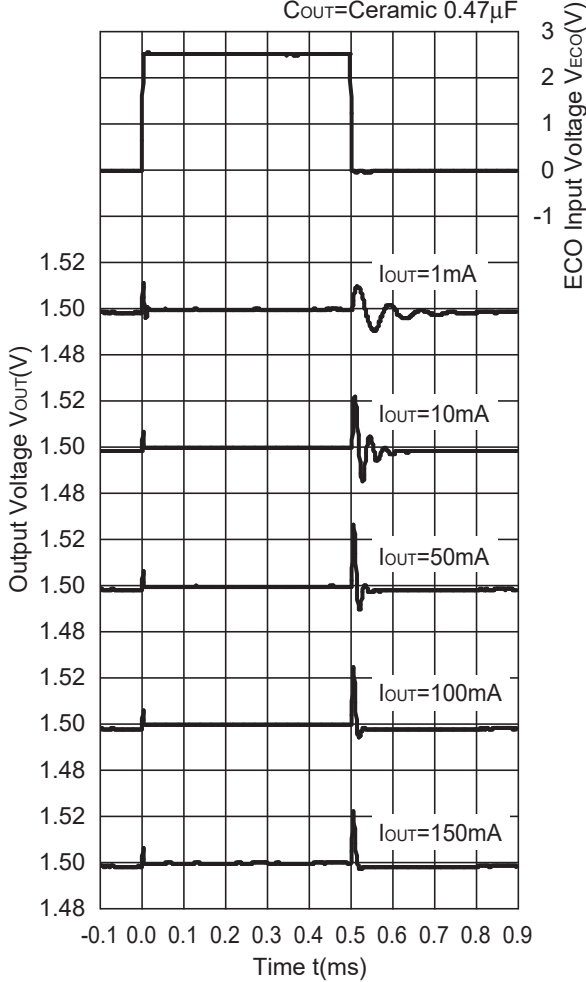

R1163x281B/D

$V_{IN}=3.8V$, C_{IN} =Ceramic $1.0\mu F$,
 C_{OUT} =Ceramic $0.47\mu F$

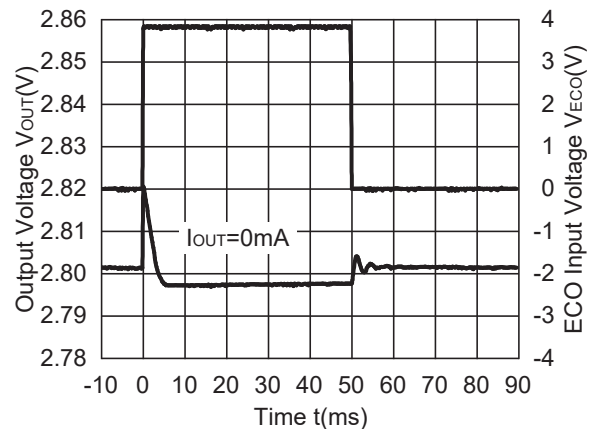
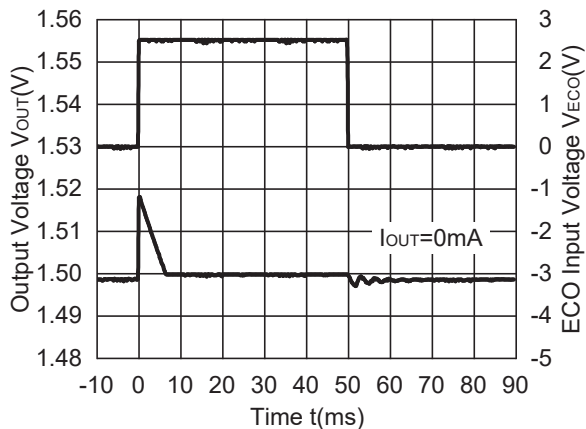
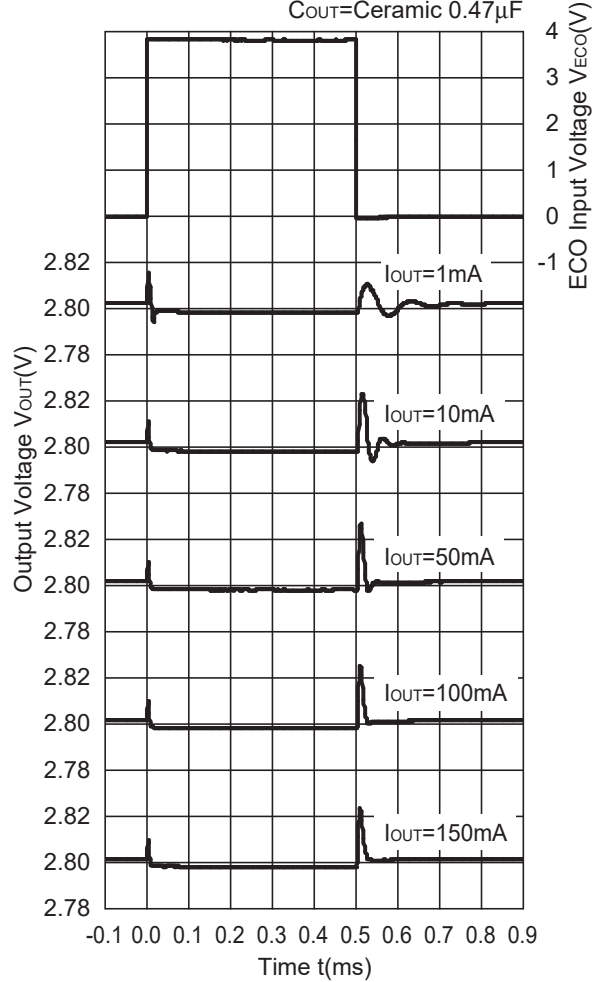

TECHNICAL NOTES

When using these ICs, consider the following points:

In these ICs, phase compensation is made for securing stable operation even if the load current is varied. For this purpose, be sure to use a capacitor C_{OUT} with good frequency characteristics and ESR (Equivalent Series Resistance) in the range described as follows:

The relations between I_{OUT} (Output Current) and ESR of Output Capacitor are shown below. The conditions when the white noise level is under $40\mu\text{V}$ (Avg.) are marked as the hatched area in the graph.

<Test conditions>

(1) Frequency band: 10Hz to 2MHz

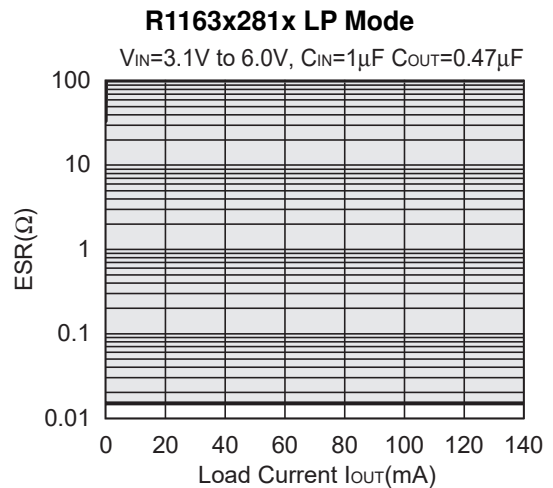
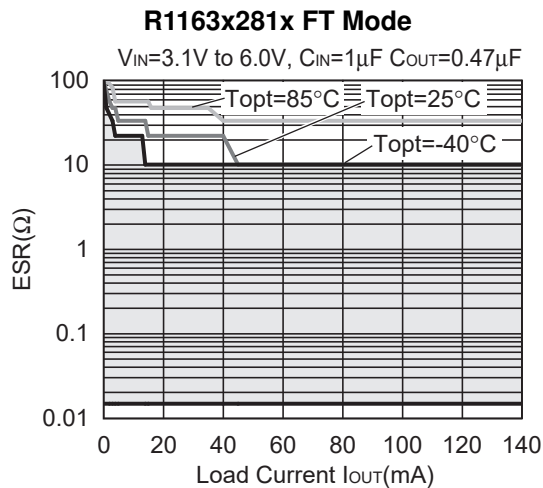
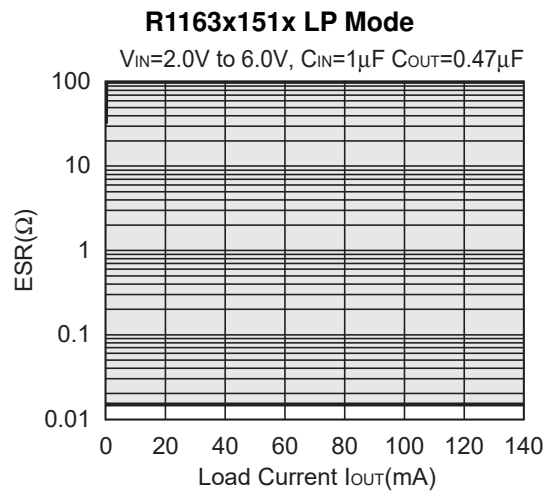
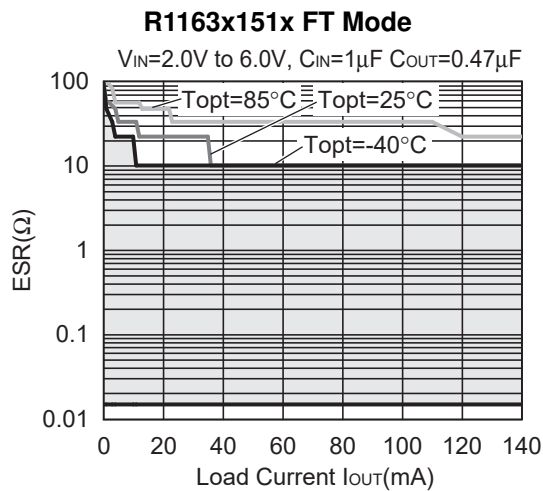

1. The products and the product specifications described in this document are subject to change or discontinuation of production without notice for reasons such as improvement. Therefore, before deciding to use the products, please refer to our sales representatives for the latest information thereon.
2. The materials in this document may not be copied or otherwise reproduced in whole or in part without the prior written consent of us.
3. This product and any technical information relating thereto are subject to complementary export controls (so-called KNOW controls) under the Foreign Exchange and Foreign Trade Law, and related politics ministerial ordinance of the law. (Note that the complementary export controls are inapplicable to any application-specific products, except rockets and pilotless aircraft, that are insusceptible to design or program changes.) Accordingly, when exporting or carrying abroad this product, follow the Foreign Exchange and Foreign Trade Control Law and its related regulations with respect to the complementary export controls.
4. The technical information described in this document shows typical characteristics and example application circuits for the products. The release of such information is not to be construed as a warranty of or a grant of license under our or any third party's intellectual property rights or any other rights.
5. The products listed in this document are intended and designed for use as general electronic components in standard applications (office equipment, telecommunication equipment, measuring instruments, consumer electronic products, amusement equipment etc.). Those customers intending to use a product in an application requiring extreme quality and reliability, for example, in a highly specific application where the failure or misoperation of the product could result in human injury or death should first contact us.
 - Aerospace Equipment
 - Equipment Used in the Deep Sea
 - Power Generator Control Equipment (nuclear, steam, hydraulic, etc.)
 - Life Maintenance Medical Equipment
 - Fire Alarms / Intruder Detectors
 - Vehicle Control Equipment (automotive, airplane, railroad, ship, etc.)
 - Various Safety Devices
 - Traffic control system
 - Combustion equipment

In case your company desires to use this product for any applications other than general electronic equipment mentioned above, make sure to contact our company in advance. Note that the important requirements mentioned in this section are not applicable to cases where operation requirements such as application conditions are confirmed by our company in writing after consultation with your company.

6. We are making our continuous effort to improve the quality and reliability of our products, but semiconductor products are likely to fail with certain probability. In order to prevent any injury to persons or damages to property resulting from such failure, customers should be careful enough to incorporate safety measures in their design, such as redundancy feature, fire containment feature and fail-safe feature. We do not assume any liability or responsibility for any loss or damage arising from misuse or inappropriate use of the products.
7. The products have been designed and tested to function within controlled environmental conditions. Do not use products under conditions that deviate from methods or applications specified in this datasheet. Failure to employ the products in the proper applications can lead to deterioration, destruction or failure of the products. We shall not be responsible for any bodily injury, fires or accident, property damage or any consequential damages resulting from misuse or misapplication of the products.
8. **Quality Warranty**
 - 8-1. **Quality Warranty Period**

In the case of a product purchased through an authorized distributor or directly from us, the warranty period for this product shall be one (1) year after delivery to your company. For defective products that occurred during this period, we will take the quality warranty measures described in section 8-2. However, if there is an agreement on the warranty period in the basic transaction agreement, quality assurance agreement, delivery specifications, etc., it shall be followed.
 - 8-2. **Quality Warranty Remedies**

When it has been proved defective due to manufacturing factors as a result of defect analysis by us, we will either deliver a substitute for the defective product or refund the purchase price of the defective product.

Note that such delivery or refund is sole and exclusive remedies to your company for the defective product.
 - 8-3. **Remedies after Quality Warranty Period**

With respect to any defect of this product found after the quality warranty period, the defect will be analyzed by us. On the basis of the defect analysis results, the scope and amounts of damage shall be determined by mutual agreement of both parties. Then we will deal with upper limit in Section 8-2. This provision is not intended to limit any legal rights of your company.
9. Anti-radiation design is not implemented in the products described in this document.
10. The X-ray exposure can influence functions and characteristics of the products. Confirm the product functions and characteristics in the evaluation stage.
11. WLCSP products should be used in light shielded environments. The light exposure can influence functions and characteristics of the products under operation or storage.
12. Warning for handling Gallium and Arsenic (GaAs) products (Applying to GaAs MMIC, Photo Reflector). These products use Gallium (Ga) and Arsenic (As) which are specified as poisonous chemicals by law. For the prevention of a hazard, do not burn, destroy, or process chemically to make them as gas or power. When the product is disposed of, please follow the related regulation and do not mix this with general industrial waste or household waste.
13. Please contact our sales representatives should you have any questions or comments concerning the products or the technical information.



Nisshinbo Micro Devices Inc.

Official website

<https://www.nisshinbo-microdevices.co.jp/en/>

Purchase information

<https://www.nisshinbo-microdevices.co.jp/en/buy/>

X-ON Electronics

Largest Supplier of Electrical and Electronic Components

Click to view similar products for [LDO Voltage Regulators](#) category:

Click to view products by [Nisshinbo](#) manufacturer:

Other Similar products are found below :

[AP7363-SP-13](#) [NCV8664CST33T3G](#) [L79M05TL-E](#) [AP7362-HA-7](#) [PT7M8202B12TA5EX](#) [TCR3DF185,LM\(CT](#) [TLF4949EJ](#)
[NCP4687DH15T1G](#) [NCV8703MX30TCG](#) [LP2951CN](#) [NCV4269CPD50R2G](#) [AP7315-25W5-7](#) [NCV47411PAAJR2G](#) [AP2111H-1.2TRG1](#)
[ZLDO1117QK50TC](#) [AZ1117ID-ADJTRG1](#) [NCV4263-2CPD50R2G](#) [NCP706ABMX300TAG](#) [NCP114BMX075TCG](#) [MC33269T-3.5G](#)
[TLE4471GXT](#) [AP7315-33SA-7](#) [NCV4266-2CST33T3G](#) [NCP715SQ15T2G](#) [NCV8623MN-50R2G](#) [NCV563SQ18T1G](#) [NCV8664CDT33RKG](#)
[NCV4299CD250R2G](#) [NCP715MX30TBG](#) [NCV8702MX25TCG](#) [TLE7270-2E](#) [NCV562SQ25T1G](#) [AP2213D-3.3TRG1](#) [AP2202K-2.6TRE1](#)
[NCV8170BMX300TCG](#) [NCV8152MX300180TCG](#) [NCP700CMT45TBG](#) [AP7315-33W5-7](#) [NCP154MX180300TAG](#) [AP2113AMTR-G1](#)
[NJW4104U2-33A-TE1](#) [MP2013AGG-5-P](#) [NCV8775CDT50RKG](#) [NJM2878F3-45-TE1](#) [S-19214B00A-V5T2U7](#) [S-19214B50A-V5T2U7](#) [S-](#)
[19213B50A-V5T2U7](#) [S-19214BC0A-E8T1U7*1](#) [S-19213B00A-V5T2U7](#) [S-19213B33A-V5T2U7](#)