

34 V Input Synchronous Step-down DC / DC Controller Evaluation Board

NO.EEV-351-032A033-0500-200729

R1272S032A033-0500EV is the evaluation board for R1272 which has the below features, benefits and specifications.

OUTLINE

The R1272S is a step-down DC/DC controller which can generate an output voltage of 0.7 V to 5.3 V by driving external high- / low-side NMOSs. By the adoption of a unique current mode PWM architecture without an external current sense resistor, the R1272S can make up a stable DC/DC converter with high-efficiency even if adding low Ron MOSFETs and a low DCR inductor externally. And, by the frequency characteristics optimization with using external phase compensation capacitor, the R1272S can achieve a high-speed response to variations of input voltage and load current. The user-settable oscillation frequency is adjustable over a range of 250 kHz to 1 MHz⁽¹⁾ by external resistors, and also can be synchronized to an external clock. Output Voltage Control Methods have three operating modes: Forced PWM mode, PLL_PWM mode, and PWM/VFM Auto-switching mode. These modes are selectable according to conditions of the MODE pin. Especially, the PWM/VFM Auto-switching mode can improve efficiency under light load conditions.

The R1272S can minimize the output voltage drop caused by an input voltage drop at cranking, with reducing the operating frequency (the lowest possible limit is a quarter of the frequency) so that the off-duty is reduced. Protection functions include a current limit function, an UVLO (Under Voltage Lock Out) function, an OVP (Over Voltage Protection) function, a soft-start function, a low-inductor current shutdown function, and so on. Also, a power good function provides the status of output with using a power good (PGOOD) pin.

For EMI reduction, SSCG (Spread-Spectrum Clock Generator) for diffused oscillation frequency at the PWM operation is optionally available.

FEATURES

- Operating Voltage (Maximum Rating) 4.0 V to 34 V (36 V)
- Operating Temperature Range -40°C ≤ Ta ≤ 105°C
(Usable in high-temperature environment)
- Start-up Voltage 4.5 V
- Output Voltage 3.3 V
- Feedback Voltage Tolerance 0.64 V ± 1%
- Consumption Current at No Load (at VFM mode) Typ.15 μA
- Adjustable Oscillation Frequency..... 500 kHz
- Synchronizable Clock Frequency... 250 kHz to 1 MHz
- Spreading Rate for SSCG Typ. ±3.6%
- Minimum On-Time ... Typ.100 ns
- Minimum Off-Time Typ.120 ns (at regulation mode)
At dropout, actual minimum off-time is reduced.
- Adjustable Soft-start Time ⁽¹⁾ Typ.500 μs
- Pre-bias Start-up

⁽¹⁾ 500 μs (Typ.) as a lower limit with using an external capacitor. Otherwise, available the tracking function through the application of an external voltage.

- Anti-phase Clock Output
- Thermal Shutdown Function $T_j = 160^{\circ}\text{C}$ (Typ.)
- Under Voltage Lockout (UVLO) Function..... Typ. 3.3 V
- Over Voltage Detection (OVD) Function V_{FB} pin voltage (V_{FB}) + 10% (Typ.)
Detection/Release Hysteresis V_{FB} pin voltage (V_{FB}) x 3% (Typ.)
- Under Voltage Detection (UVD) Function..... V_{FB} pin voltage (V_{FB}) - 10% (Typ.)
Detection/Release Hysteresis V_{FB} pin voltage (V_{FB}) x 3% (Typ.)
- Over-current Protection Hiccup-mode / Latch mode
- Selectable Current Limit Threshold..... 70 mV
- Power Good Output NMOS Open-drain Output
- Package..... HSOP-18
- For more details on R1272 IC, please refer to
<https://www.n-redc.co.jp/en/pdf/datasheet/r1272-ea.pdf>.

PART NUMBER INFORMATION

Product Name	Package
R1272S032A033-0500	HSOP-18

03: Combination of processing and function.

Over Current Protection	SSCG
Latch mode	Enable

2: 70 mV, Set Voltage for Current Limit Threshold (Typ.)

A: Fixed

033: 3.3 V, Output Voltage

0500: 500 kHz, Frequency

PCB LAYOUT

R1272SxxxA PCB Layouts

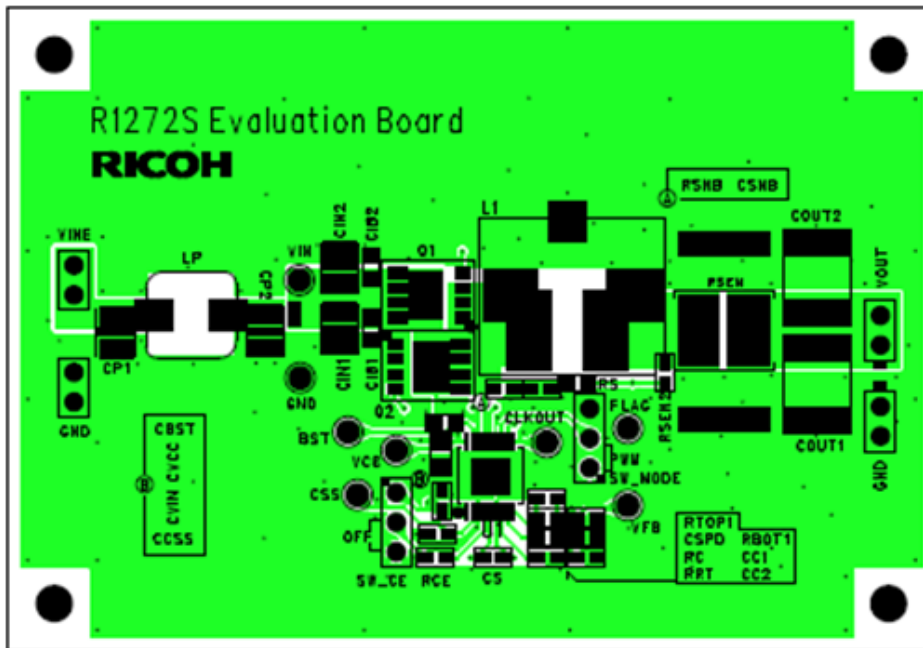

PCB Layout – 1st Layer (Top Layer)

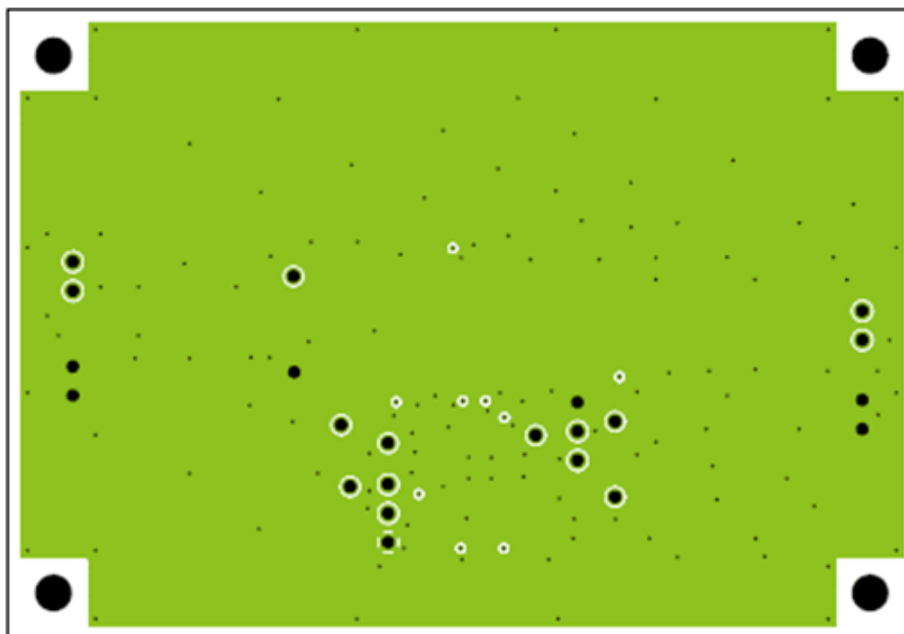

PCB Layout – 2nd Layer

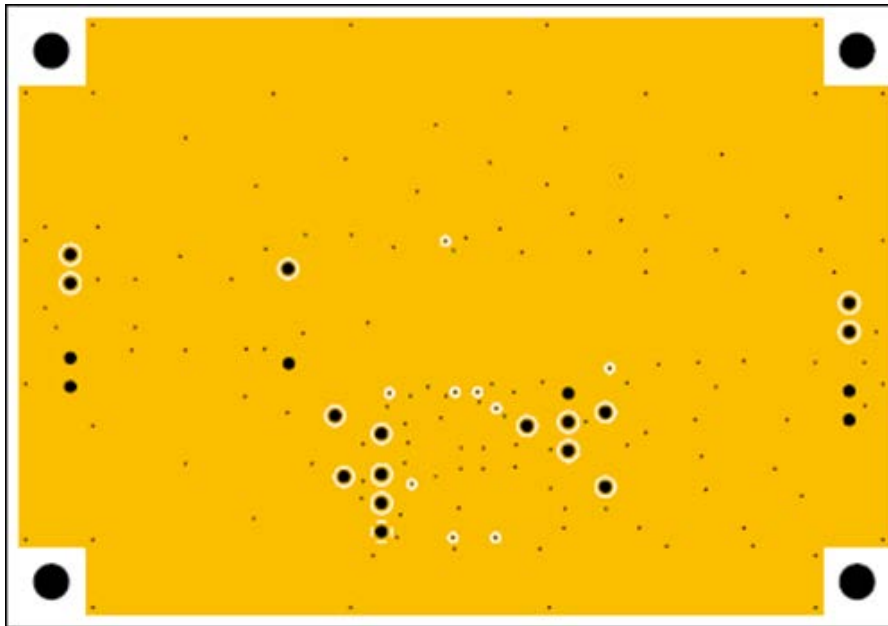

PCB Layout - 3rd Layer

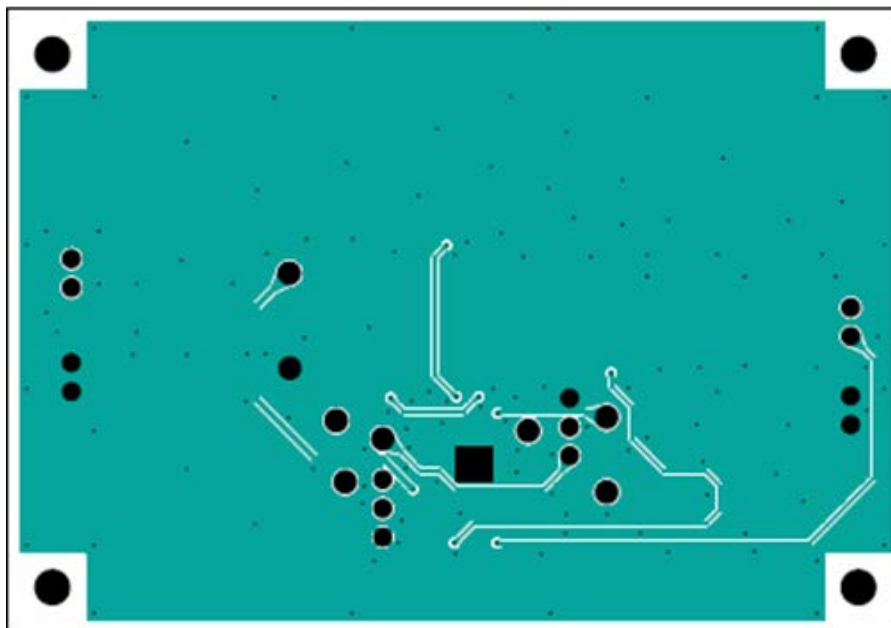

PCB Layout - 4th Layer (Bottom Layer)
R1272SxxxA

PIN DESCRIPTIONS

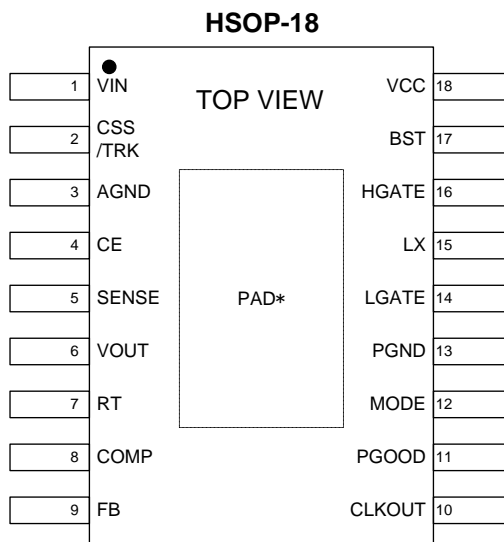

HSOP-18 Pin Description

Pin No.	Pin Name	Description
1	VIN	Power supply pin
2	CSS/TRK	Soft-start adjustment pin
3	AGND	Analog GND pin
4	CE	Chip enable pin (Active "H")
5	SENSE	Sense pin for inductor current
6	VOUT	Output voltage feedback input pin
7	RT	Oscillation adjustment pin
8	COMP	Capacitor connecting pin for phase compensation of error amplifier
9	FB	Feedback input pin to the error amplifier
10	CLKOUT	Clock output pin
11	PGOOD	Power-good output pin
12	MODE	Mode-set input pin
13	PGND	Power GND pin
14	LGATE	L-side FET control pin
15	LX	Switching pin
16	HGATE	H-side FET control pin
17	BST	Bootstrap pin
18	VCC	VCC output pin

* The tab on the bottom of the package must be electrically connected to GND (substrate level) when mounted on the board.

ABSOLUTE MAXIMUM RATINGS

Symbol	Item	Rating	Unit
V_{IN}	VIN pin voltage	-0.3 to 36	V
V_{CE}	CE pin voltage	-0.3 to 36	V
V_{CSS}/V_{TRK}	CSS/TRK pin voltage	-0.3 to 3	V
V_{OUT}	VOUT pin voltage	-0.3 to 6	V
V_{SENSE}	SENSE pin voltage	-0.3 to 6	V
V_{RT}	RT pin voltage	-0.3 to 3	V
V_{COMP}	COMP pin voltage ⁽¹⁾	-0.3 to 6	V
V_{FB}	FB pin voltage	-0.3 to 3	V
V_{CC}	VCC pin voltage	-0.3 to 6	V
	Output current for VCC pin	Internally limited	mA
V_{BST}	BST pin voltage	LX-0.3 to LX+6	V
V_{HGATE}	HGATE pin voltage	LX-0.3 to BST	V
V_{LX}	LX pin voltage ⁽²⁾	-0.3 to 36	V
V_{LGATE}	LGATE pin voltage ⁽¹⁾	-0.3 to 6	V
V_{MODE}	MODE pin voltage	-0.3 to 6	V
V_{PGOOD}	PGOOD pin voltage	-0.3 to 6	V
V_{CLKOUT}	CLKOUT pin voltage ⁽¹⁾	-0.3 to 6	V
P_D	Power Dissipation ⁽³⁾ (HSOP-18, JEDEC STD.51-7 Test Land Pattern)	3100	mW
T_j	Junction Temperature	-40 to 125	°C
T_{stg}	Storage Temperature Range	-55 to 125	°C

ABSOLUTE MAXIMUM RATINGS

Electronic and mechanical stress momentarily exceeded absolute maximum ratings may cause permanent damage and may degrade the life time and safety for both device and system using the device in the field.
The functional operation at or over these absolute maximum ratings are not assured.

RECOMMENDED OPERATING CONDITIONS

Symbol	Item	Rating	Unit
V_{IN}	Input Voltage	4.0 to 34	V
T_a	Operating Temperature Range	-40 to 105	°C
V_{OUT}	Output Voltage Range	0.7 to 5.3	V

RECOMMENDED OPERATING CONDITIONS

All of electronic equipment should be designed that the mounted semiconductor devices operate within the recommended operating conditions. The semiconductor devices cannot operate normally over the recommended operating conditions, even if they are used over such ratings by momentary electronic noise or surge. And the semiconductor devices may receive serious damage when they continue to operate over the recommended operating conditions.

⁽¹⁾ The pin voltage must be prevented from exceeding $V_{CC} + 0.3V$.

⁽²⁾ The pin voltage must be prevented from exceeding $V_{IN} + 0.3V$.

⁽³⁾ Refer to *POWER DISSIPATION* for detailed information.

ELECTRICAL CHARACTERISTICS

$V_{IN} = 12\text{ V}$, $CE = V_{IN}$, unless otherwise specified.

The specifications surrounded by are guaranteed by design engineering at $-40^{\circ}\text{C} \leq T_a \leq 105^{\circ}\text{C}$.

R1272SxxxA

($T_a = 25^{\circ}\text{C}$)

Symbol	Item	Conditions	Min.	Typ.	Max.	Unit
V_{START}	Start-up Voltage				4.5	V
V_{CC}	VCC Pin Voltage (VCC-AGND)	$V_{FB} = 0.672\text{ V}$	4.9	5.1	5.3	V
$I_{STANDBY}$	Standby Current	$V_{IN} = 34\text{ V}$, $CE = 0\text{ V}$		3	20	μA
I_{VIN1}	VIN Consumption Current 1 at Switching Stop in PWM mode	R1272S0xx $V_{FB} = 0.672\text{ V}$, MODE = 5 V, $V_{OUT} = \text{SENSE} = \text{LX} = 5\text{ V}$		1.0	1.3	mA
I_{VIN2}	VIN Consumption Current 2 at Switching Stop in VFM mode	R1272S0xx $V_{FB} = 0.672\text{ V}$, MODE = 0 V $V_{OUT} = \text{SENSE} = \text{LX} = 5\text{ V}$		15	75	μA
V_{UVLO2}	UVLO Threshold Voltage	VCC Rising	3.85	4.0	4.2	V
V_{UVLO1}		VCC Falling	3.1	3.3	3.4	V
V_{FB}	FB Voltage Accuracy	$T_a = 25^{\circ}\text{C}$	0.6336	0.64	0.6464	V
		$-40^{\circ}\text{C} \leq T_a \leq 105^{\circ}\text{C}$	0.6272		0.6528	
f_{OSC0}	Oscillation Frequency 0	$R_T = 135\text{ k}\Omega$	225	250	275	kHz
f_{OSC1}	Oscillation Frequency 1	$R_T = 32\text{ k}\Omega$	900	1000	1100	kHz
t_{OFF}	Minimum OFF Time	$V_{IN} = 5\text{ V}$, $V_{OUT} = 5\text{ V}$		120	190	ns
t_{ON}	Minimum ON Time			100	120	ns
f_{SYNC}	Synchronizing Frequency	f_{OSC} as the reference	$f_{OSC} \times 0.5$		$f_{OSC} \times 1.5$	kHz
			250		1000	
t_{SS1}	Soft-start Time 1	CSS / TRK = OPEN	0.4		0.75	ms
t_{SS2}	Soft-start Time 2	$C_{SS} = 4.7\text{ nF}$	1.4		2.0	ms
I_{TSS}	Charge Current for Soft-start Pin	CSS / TRK = 0 V	1.8	2	2.2	μA
V_{SSEND}	CSS/TRK Pin Voltage at End of Soft-start		V_{FB}	$V_{FB} + 0.03$	$V_{FB} + 0.06$	V
R_{DIS_CSS}	Discharge Resistance for CSS/TRK Pin	$V_{IN} = 4.5\text{ V}$, $CE = 0\text{ V}$, CSS / TRK = 3 V	2.0	3.0	5.0	k Ω
$R_{UPHGATE}$	On-resistance of Pull-up Transistor (HGATE Pin)	(BST - LX) = 5 V, $I_{HGATE} = -100\text{ mA}$		2.5	5.0	Ω

$V_{IN} = 12\text{ V}$, $CE = V_{IN}$, unless otherwise specified.

The specifications surrounded by are guaranteed by design engineering at $-40^{\circ}\text{C} \leq T_a \leq 105^{\circ}\text{C}$.

R1272SxxxA Continued

(Ta = 25°C)

Symbol	Item	Conditions	Min.	Typ.	Max.	Unit
$R_{\text{DOWNHGATE}}$	On-resistance of Pull-down Transistor (HGATE Pin)	(BST – LX) = 5 V, $I_{\text{HGATE}} = 100\text{ mA}$		1.5	3.5	Ω
R_{UPLGATE}	On-resistance of Pull-up Transistor (LGATE Pin)	(VCC – PGND) = 5 V, $I_{\text{LGATE}} = -100\text{ mA}$		4.0	7.0	Ω
$R_{\text{DOWNLGATE}}$	On-resistance of Pull-down Transistor (LGATE Pin)	(VCC – PGND) = 5 V, $I_{\text{LGATE}} = 100\text{ mA}$		1.5	3.5	Ω
V_{LIMIT}	Current Limit Threshold Voltage (SENSE – VOUT)		40	50	60	mV
			60	70	80	mV
			90	100	110	mV
$V_{\text{IREVLIMIT}}$	Reverse Current Sense Threshold (SENSE – VOUT)	MODE = H / CLK	-35	-25	-15	mV
			-45	-35	-25	mV
			-60	-50	-40	mV
V_{LXSHORTL}	LX Shot to GND Detector Threshold Voltage (VIN – LX)		0.345	0.43	0.520	V
V_{LXSHORTH}	LX Short to VCC Detector Threshold Voltage (LX – PGND)		0.330	0.43	0.515	V
V_{CEH}	CE "High" Input Voltage		1.27			V
V_{CEL}	CE "Low" Input Voltage				1.14	V
I_{CEH}	CE "High" Input Current	CE = 34 V	0.20		2.45	μA
I_{CEL}	CE "Low" Input Current	CE = 0 V	-1.00	0	1.00	μA
I_{FBH}	FB "High" Input Current	$V_{\text{FB}} = 3\text{ V}$	-0.10		0.10	μA
I_{FBL}	FB "Low" Input Current	$V_{\text{FB}} = 0\text{ V}$	-0.10		0.10	μA
V_{MODEH}	MODE "High" Input Voltage		1.33			V
V_{MODEL}	MODE "Low" Input Voltage				0.74	V
I_{MODEH}	MODE "High" Input Current	MODE = 6 V	1.00		6.60	μA
I_{MODEL}	MODE "Low" Input Current	MODE = 0 V	-1.00	0	1.00	μA
V_{CLKOUTH}	CLKOUT Pin "High" Output Voltage	CLKOUT = Hi-z	4.7		V_{CC}	V
V_{CLKOUTL}	CLKOUT Pin "Low" Output Voltage	CLKOUT = Hi-z	0		0.1	V
T_{TSD}	Thermal Shutdown Threshold Temperature	Ta Rising	150	160		$^{\circ}\text{C}$
T_{TSR}		Ta Falling	125	140		$^{\circ}\text{C}$

$V_{IN} = 12\text{ V}$, $CE = V_{IN}$, unless otherwise specified.

The specifications surrounded by are guaranteed by design engineering at $-40^{\circ}\text{C} \leq T_a \leq 105^{\circ}\text{C}$.

R1272SxxxA Continued

(Ta = 25°C)

Symbol	Item	Conditions	Min..	Typ	Max.	Unit
V _{PGOODOFF}	PGOOD Pin "OFF" Voltage	V _{IN} = 4.0 V, PGOOD = 1 mA		0.26	0.54	V
I _{PGOODOFF}	PGOOD Pin "OFF" Current	V _{IN} = 34 V, CE = 0 V, PGOOD = 6 V	-0.10	0	0.10	μA
V _{FBOVD1}	FB Pin OVD Threshold Voltage	V _{FB} Rising	0.680	V _{FB} ×1.10	0.740	V
V _{FBOVD2}		V _{FB} Falling	0.664	V _{FB} ×1.07	0.712	V
V _{FBUVD1}	FB Pin UVD Threshold Voltage	V _{FB} Falling	0.556	V _{FB} ×0.90	0.604	V
V _{FBUVD2}		V _{FB} Rising	0.574	V _{FB} ×0.93	0.628	V
gm (EA)	Trans Conductance Amplifier	COMP = 1.5 V	0.35	1	1.55	mS

All test items listed under Electrical Characteristics are done under the pulse load condition (T_j ≈ T_a = 25°C).

APPLICATION INFORMAITON

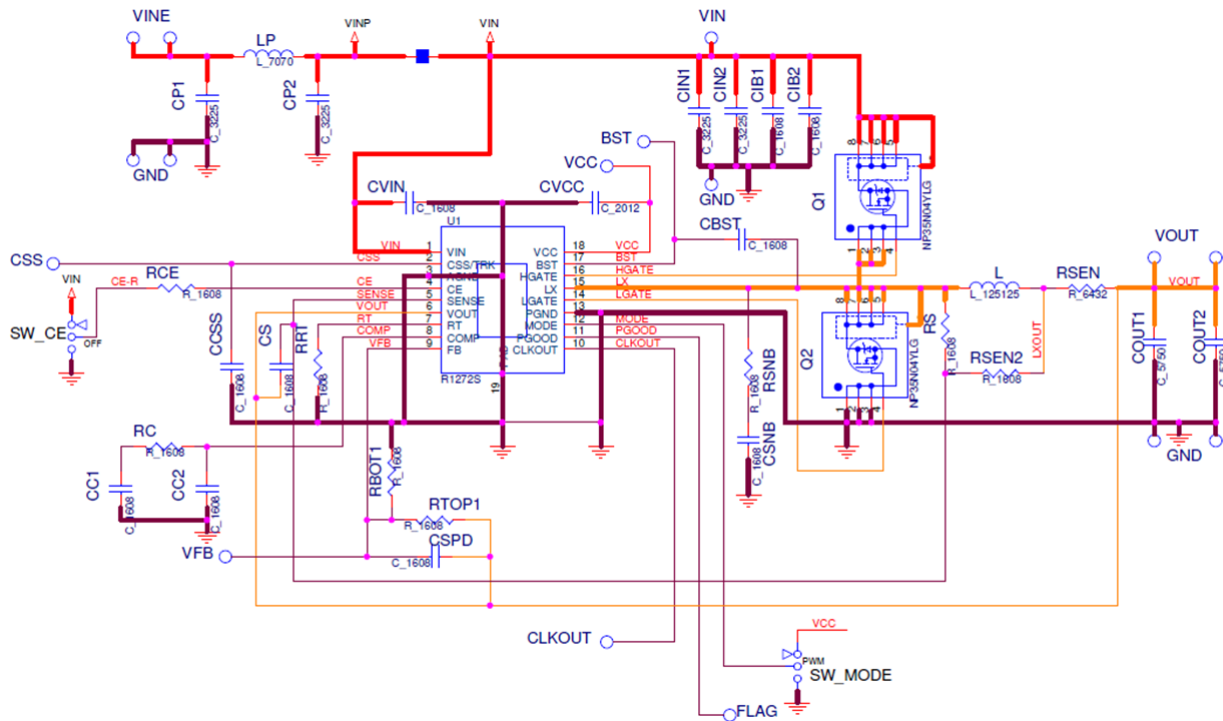

R1272SxxxA Typical Application Circuit at 500 kHz

R1272S032A033-0500 Recommended External Components⁽¹⁾

CP1 [μF]	LP [μH]	CP2 [μF]	Q1(FET)	Q2(FET)	L [μH]	CIN1 [μF]	CIN2 [μF]
10	1.0	10	—	—	2.2	10	10
CVIN	COUT 1 [μF]	COUT2 [μF]	CBST [μF]	CVCC [μF]	CCSS [nF]	CSPD [pF]	CC1 [nF]
OPEN	100	22*2	0.22	2.2	3.3	100	6.8
CC2 [pF]	RTOP1 [kΩ]	RBOT1 [kΩ]	RC [kΩ]	RRT [kΩ]	RS	RSEN [mΩ]	RSEN2 [kΩ]
47	91.43	22	12	68	OPEN	3	1
RCE [Ω]							
0							

⁽¹⁾ The bill of materials will be attached on the shipment of each purchased evaluation board.

TECHNICAL NOTES

The performance of power source circuits using this IC largely depends on peripheral circuits. When selecting the peripheral components, please consider the conditions of use. Do not allow each component, PCB pattern or the IC to exceed their respected rated values (voltage, current, and power) when designing the peripheral circuits.

- External components must be connected as close as possible to the ICs and make wiring as short as possible. Especially, the capacitor connected in between VIN pin and GND pin must be wiring the shortest. If their impedance is high, internal voltage of the IC may shift by the switching current, and the operating may be unstable. Make the power supply and GND lines sufficient.
- Place a capacitor (C_{OUT}) to keep a distance between C_{IN} and C_{OUT} in order to avoid the high-frequency noise by input.
- AGND and PGND for the controller must be wired to the GND line at the low impedance point of the same layer with C_{IN} and C_{OUT} .
- Place a capacitor (C_{BST}) as close as possible to the LX pin and the BST pin. If controlling slew rate for EMI, a resistor (R_{BST}) should be in series between the BST pin and the capacitor (C_{BST}), but not be in series to FET for HGATE and LGATE pins. Because connecting the resistor in series to the FET becomes a cause of a through-current.
- The tab on the bottom of the HSOP-18 package must be connected to GND when mounted on the board. To improve thermal dissipation on the multilayer board, set via to release the heat to the other layer in the connecting part of the tab on the bottom. Likewise, thermal dissipation for FET is required.
- The NC pin must be set to "Open".
- The MODE pin requires the H / L voltages with the high stability when the forced PWM mode (MODE = "H") or the VFM mode (MODE = "L") is enabled. If the voltage with the high stability cannot be applied, connection to the VCC pin as "H" level or the AGND pin as "L" level is recommended. If connecting to the PGND pin as noisy, a malfunction may occur. Avoid the use of the MODE pin being "Open".
- If V_{OUT} is a minus potential, the setup cannot occur.
- The power for the controller and for the high-side FET must be used on the same power supply, since the internal slope compensation is applied as the power supply voltage of the high-side FET is equal to the controller's. If applying the other power supply voltage, the controller will become unstable owing to the inappropriate slope compensation.



1. The products and the product specifications described in this document are subject to change or discontinuation of production without notice for reasons such as improvement. Therefore, before deciding to use the products, please refer to Ricoh sales representatives for the latest information thereon.
2. The materials in this document may not be copied or otherwise reproduced in whole or in part without prior written consent of Ricoh.
3. Please be sure to take any necessary formalities under relevant laws or regulations before exporting or otherwise taking out of your country the products or the technical information described herein.
4. The technical information described in this document shows typical characteristics of and example application circuits for the products. The release of such information is not to be construed as a warranty of or a grant of license under Ricoh's or any third party's intellectual property rights or any other rights.
5. The products listed in this document are intended and designed for use as general electronic components in standard applications (office equipment, telecommunication equipment, measuring instruments, consumer electronic products, amusement equipment etc.). Those customers intending to use a product in an application requiring extreme quality and reliability, for example, in a highly specific application where the failure or misoperation of the product could result in human injury or death (aircraft, spacevehicle, nuclear reactor control system, traffic control system, automotive and transportation equipment, combustion equipment, safety devices, life support system etc.) should first contact us.
6. We are making our continuous effort to improve the quality and reliability of our products, but semiconductor products are likely to fail with certain probability. In order to prevent any injury to persons or damages to property resulting from such failure, customers should be careful enough to incorporate safety measures in their design, such as redundancy feature, fire containment feature and fail-safe feature. We do not assume any liability or responsibility for any loss or damage arising from misuse or inappropriate use of the products.
7. Anti-radiation design is not implemented in the products described in this document.
8. The X-ray exposure can influence functions and characteristics of the products. Confirm the product functions and characteristics in the evaluation stage.
9. WLCSP products should be used in light shielded environments. The light exposure can influence functions and characteristics of the products under operation or storage.
10. There can be variation in the marking when different AOI (Automated Optical Inspection) equipment is used. In the case of recognizing the marking characteristic with AOI, please contact Ricoh sales or our distributor before attempting to use AOI.
11. Please contact Ricoh sales representatives should you have any questions or comments concerning the products or the technical information.



Ricoh is committed to reducing the environmental loading materials in electrical devices with a view to contributing to the protection of human health and the environment.

Ricoh has been providing RoHS compliant products since April 1, 2006 and Halogen-free products since April 1, 2012.

RICOH RICOH ELECTRONIC DEVICES CO., LTD.

Official website

<https://www.n-redc.co.jp/en/>

Contact us

<https://www.n-redc.co.jp/en/buy/>

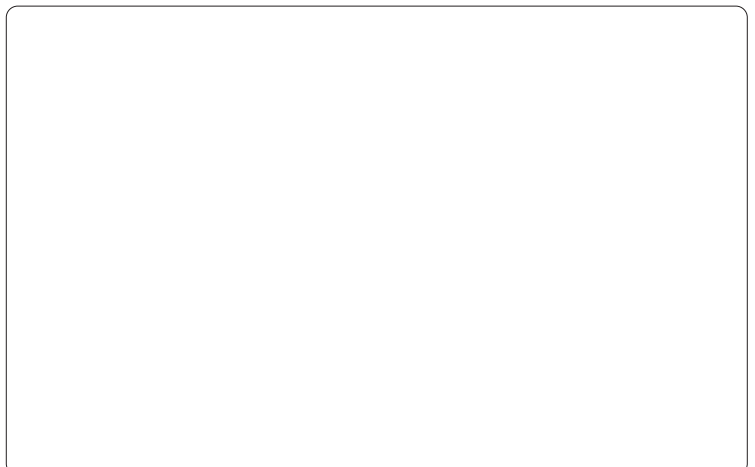

X-ON Electronics

Largest Supplier of Electrical and Electronic Components

Click to view similar products for [Power Management IC Development Tools](#) category:

Click to view products by [Nisshinbo](#) manufacturer:

Other Similar products are found below :

[EVAL-ADM1168LQEBZ](#) [EVB-EP5348UI](#) [MIC23451-AAAYFL EV](#) [MIC5281YMME EV](#) [DA9063-EVAL](#) [ADP122-3.3-EVALZ](#) [ADP130-0.8-EVALZ](#) [ADP130-1.2-EVALZ](#) [ADP130-1.5-EVALZ](#) [ADP130-1.8-EVALZ](#) [ADP1714-3.3-EVALZ](#) [ADP1716-2.5-EVALZ](#) [ADP1740-1.5-EVALZ](#) [ADP1752-1.5-EVALZ](#) [ADP1828LC-EVALZ](#) [ADP1870-0.3-EVALZ](#) [ADP1871-0.6-EVALZ](#) [ADP1873-0.6-EVALZ](#) [ADP1874-0.3-EVALZ](#) [ADP1882-1.0-EVALZ](#) [ADP199CB-EVALZ](#) [ADP2102-1.25-EVALZ](#) [ADP2102-1.875EVALZ](#) [ADP2102-1.8-EVALZ](#) [ADP2102-2-EVALZ](#) [ADP2102-3-EVALZ](#) [ADP2102-4-EVALZ](#) [ADP2106-1.8-EVALZ](#) [ADP2147CB-110EVALZ](#) [AS3606-DB](#) [BQ24010EVM](#) [BQ24075TEVM](#) [BQ24155EVM](#) [BQ24157EVM-697](#) [BQ24160EVM-742](#) [BQ24296MEVM-655](#) [BQ25010EVM](#) [BQ3055EVM](#) [NCV891330PD50GEVB](#) [ISLUSBI2CKIT1Z](#) [LM2744EVAL](#) [LM2854EVAL](#) [LM3658SD-AEV/NOPB](#) [LM3658SDEV/NOPB](#) [LM3691TL-1.8EV/NOPB](#) [LM4510SDEV/NOPB](#) [LM5033SD-EVAL](#) [LP38512TS-1.8EV](#) [EVAL-ADM1186-1MBZ](#) [EVAL-ADM1186-2MBZ](#)