

#### 150 mA Voltage Regulator (Wide Input Voltage Range) for Automotive Applications

NO. EC-152-160930

## OUTLINE

The R1514x is a CMOS-based positive voltage regulator (VR) IC featuring 150 mA output current. It is specifically designed for automotive applications. The R1514xxxxB has features of high input voltage and ultra-low supply current. A peak current limit circuit, a short current limit circuit, and a thermal shutdown circuit are built in the R1514x.

The operating temperature is  $-40^{\circ}\text{C}$  to  $105^{\circ}\text{C}$  and the maximum input voltage is 36 V, the R1514x is very suitable for power source of car accessories.

The regulator output voltage is fixed in the R1514xxxxB and can be selected with a step of 0.1 V in the range of 2.0 V to 12.0 V. The Output voltage accuracy is  $\pm 2\%$ .

The packages for this IC are the SOT-89-5 for space saving and the HSOP-6J for higher power applications.

## FEATURES

- Input Voltage Range (Maximum Rating) ..... 4 V to 36 V (50 V)
- Operating Temperature .....  $-40^{\circ}\text{C}$  to  $105^{\circ}\text{C}$
- Supply Current ( $I_{\text{SS}}$ ) ..... Typ. 9  $\mu\text{A}$
- Standby Current ( $I_{\text{standby}}$ ) ..... Typ. 0.1  $\mu\text{A}$
- Temperature-Drift Coefficient of Output Voltage .. Typ.  $\pm 100$  ppm/ $^{\circ}\text{C}$
- Output Current ( $I_{\text{OUT}}$ ) ..... Min. 150 mA ( $V_{\text{IN}} = V_{\text{OUT}} + 3.0$  V; R1514x050B)
- Line Regulation..... Typ. 0.05%/V
- Output Voltage Accuracy .....  $\pm 2\%$
- Output Voltage Range ( $V_{\text{OUT}}$ ) ..... 2.0 V to 12.0 V (0.1 V step)
- Packages..... SOT-89-5, HSOP-6J
- Built-in Short Current Limit Circuit..... Typ. 50 mA
- Built-in Peak Current Limit Circuit
- Built-in Thermal Shutdown Circuit

## APPLICATIONS

- Power source for car accessories including car audio equipment, car navigation system, and ETC system.
- Power source for control units including EV inverter and charge control.

**BLOCK DIAGRAM**

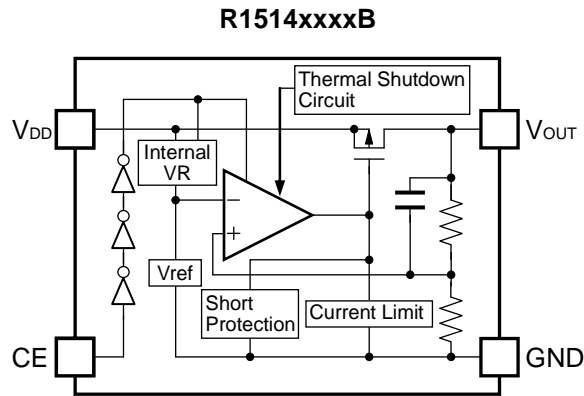

**SELECTION GUIDE**

The output voltage, package for the ICs can be selected at the user's request.

Product Name	Package	Quantity per Reel	Pb Free	Halogen Free
R1514HxxxB-T1-#E	SOT-89-5	1,000 pcs	Yes	Yes
R1514SxxxB-E2-#E	HSOP-6J	1,000 pcs	Yes	Yes

xxx: The output voltage ( $V_{OUT}$ ) can be designated in the range of 2.0 V (020) to 12.0 V (120) in 0.1 V step.

#: Specify Automotive Class Code

	Operating Temperature Range	Guaranteed Specs Temperature Range	Screening
A	-40°C to 105°C	25°C	High temperature
J	-40°C to 105°C	-40°C to 105°C	High and low temperature

## PIN DESCRIPTIONS

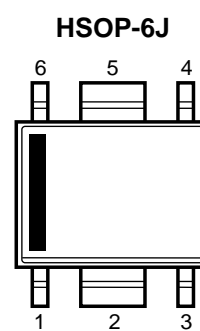
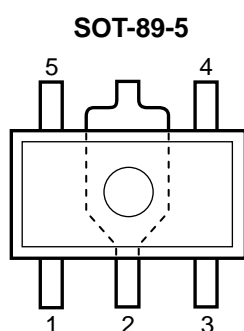

### SOT-89-5

Pin No.	Symbol	Description
1	$V_{OUT}$	Output Pin
2	GND <sup>*1</sup>	Ground Pin
3	CE	Chip Enable Pin, Active-high.
4	GND <sup>*1</sup>	Ground Pin
5	$V_{DD}$	Input Pin

<sup>\*1</sup> The GND pin must be wired together when it is mounted on board.

### HSOP-6J

Pin No.	Symbol	Description
1	$V_{OUT}$	Output Pin
2	GND <sup>*2</sup>	Ground Pin
3	CE	Chip Enable Pin, Active-high.
4	GND <sup>*2</sup>	Ground Pin
5	GND <sup>*2</sup>	Ground Pin
6	$V_{DD}$	Input Pin

<sup>\*2</sup> The GND pin must be wired together when it is mounted on board.

## ABSOLUTE MAXIMUM RATINGS

Symbol	Item	Rating	Unit	
$V_{IN}$	Input Voltage	-0.3 to 50	V	
$V_{IN}$	Peak Input Voltage <sup>*3</sup>	60	V	
$V_{CE}$	Input Voltage (CE Pin)	-0.3 to $V_{IN} + 0.3 \leq 50$	V	
$V_{OUT}$	Output Voltage	-0.3 to $V_{IN} + 0.3 \leq 50$	V	
$I_{OUT}$	Output Current	250	mA	
$P_D$	Power Dissipation (SOT-89-5) <sup>*4</sup>	Standard Land Pattern	1120	mW
		High Wattage Land Pattern	1620	
	Power Dissipation (HSOP-6J) <sup>*4</sup>	Standard Land Pattern	2100	
		Ultra High Wattage Land Pattern	3400	
$T_j$	Junction Temperature	-40 to 150	°C	
$T_{stg}$	Storage Temperature Range	-55 to 150	°C	

<sup>\*3</sup> Duration time = 200 ms

<sup>\*4</sup> Refer to *POWER DISSIPATION* for detailed information.

### ABSOLUTE MAXIMUM RATINGS

Electronic and mechanical stress momentarily exceeded absolute maximum ratings may cause the permanent damages and may degrade the life time and safety for both device and system using the device in the field. The functional operation at or over these absolute maximum ratings is not assured.

## RECOMMENDED OPERATING CONDITIONS

Symbol	Item	Rating	Unit
$V_{IN}$	Input Voltage	4 to 36	V
$T_a$	Operating Temperature Range	-40 to 105	°C

### RECOMMENDED OPERATING CONDITIONS

All of electronic equipment should be designed that the mounted semiconductor devices operate within the recommended operating conditions. The semiconductor devices cannot operate normally over the recommended operating conditions, even if when they are used over such conditions by momentary electronic noise or surge. And the semiconductor devices may receive serious damage when they continue to operate over the recommended operating conditions.

## ELECTRICAL CHARACTERISTICS

The specifications surrounded by  $\square$  are guaranteed by design engineering at  $-40^{\circ}\text{C} \leq T_a \leq 105^{\circ}\text{C}$ .

### R1514xxxxB (-AE)

( $T_a = 25^{\circ}\text{C}$ )

Symbol	Item	Conditions	Min.	Typ.	Max.	Unit
$I_{SS}$	Supply Current	$V_{IN} = V_{OUT} + 3.0\text{ V}$ , $I_{OUT} = 0\text{ mA}$		9	$\square 20$	$\mu\text{A}$
$I_{standby}$	Standby Current	$V_{IN} = 36\text{ V}$ , $V_{CE} = 0\text{ V}$		0.1	$\square 1.0$	$\mu\text{A}$
$V_{OUT}$	Output Voltage	$V_{IN} = V_{OUT} + 3.0\text{ V}$ , $I_{OUT} = 1\text{ mA}$		$\times 0.98$	$\times 1.02$	V
				$\square \times 0.97$	$\square \times 1.03$	V
$I_{OUT}$	Output Current	$V_{IN} = V_{OUT} + 3.0\text{ V}$	Refer to the <i>Product-specific Electrical Characteristics</i>			
$\Delta V_{OUT}/\Delta I_{OUT}$	Load Regulation	$V_{IN} = V_{OUT} + 3.0\text{ V}$ , $1\text{ mA} \leq I_{OUT} \leq 40\text{ mA}$				
$\Delta V_{OUT}/\Delta V_{IN}$	Line Regulation	$V_{OUT} + 1.5\text{ V} \leq V_{IN} \leq 36\text{ V}$ , $I_{OUT} = 1\text{ mA}$		0.05	$\square 0.20$	%/V
$V_{DIF}$	Dropout Voltage	$I_{OUT} = 20\text{ mA}$	Refer to the <i>Product-specific Electrical Characteristics</i>			
$I_{SC}$	Short Current Limit	$V_{OUT} = 0\text{ V}$		50		mA
$V_{CEH}$	CE Input Voltage "H"		$\square 1.5$		$V_{IN}$	V
$V_{CEL}$	CE Input Voltage "L"		0.0		$\square 0.3$	V
$T_{TSD}$	Thermal Shutdown Temperature	Junction Temperature	$\square 150$	160		$^{\circ}\text{C}$
$T_{TSR}$	Thermal Shutdown Released Temperature	Junction Temperature	$\square 110$	130		$^{\circ}\text{C}$

All test items listed under Electrical Characteristics are done under the pulse load condition ( $T_j \approx T_a = 25^{\circ}\text{C}$ ).

# R1514x

NO. EC-152-160930

The specifications surrounded by   are guaranteed by design engineering at  $-40^{\circ}\text{C} \leq T_a \leq 105^{\circ}\text{C}$ .

## Product-specific Electrical Characteristics

R1514xxxxB (-AE)

( $T_a = 25^{\circ}\text{C}$ )

Product Name	V <sub>OUT</sub> [V]						I <sub>OUT</sub> [mA]				ΔV <sub>OUT</sub> /ΔI <sub>OUT</sub> [mV]	V <sub>DIF</sub> [V]		
	T <sub>a</sub> = 25°C			-40°C ≤ T <sub>a</sub> ≤ 105°C			T <sub>a</sub> = 25°C	-40°C ≤ T <sub>a</sub> ≤ 105°C				TYP.	T <sub>a</sub> = 25°C	-40°C ≤ T <sub>a</sub> ≤ 105°C
	MIN.	TYP.	MAX.	MIN.	TYP.	MAX.	MIN.	MIN.	TYP.	MAX.	MAX.		MAX.	
R1514x020B	1.960	2.000	2.040	<span style="border: 1px solid black; padding: 0 2px;">1.940</span>	2.000	<span style="border: 1px solid black; padding: 0 2px;">2.060</span>	100	<span style="border: 1px solid black; padding: 0 2px;">90</span>	10	<span style="border: 1px solid black; padding: 0 2px;">25</span>	-	2.00	<span style="border: 1px solid black; padding: 0 2px;">2.0</span>	
R1514x021B	2.058	2.100	2.142	<span style="border: 1px solid black; padding: 0 2px;">2.037</span>	2.100	<span style="border: 1px solid black; padding: 0 2px;">2.163</span>						1.90	<span style="border: 1px solid black; padding: 0 2px;">1.9</span>	
R1514x022B	2.156	2.200	2.244	<span style="border: 1px solid black; padding: 0 2px;">2.134</span>	2.200	<span style="border: 1px solid black; padding: 0 2px;">2.266</span>						1.80	<span style="border: 1px solid black; padding: 0 2px;">1.8</span>	
R1514x023B	2.254	2.300	2.346	<span style="border: 1px solid black; padding: 0 2px;">2.231</span>	2.300	<span style="border: 1px solid black; padding: 0 2px;">2.369</span>						1.70	<span style="border: 1px solid black; padding: 0 2px;">1.7</span>	
R1514x024B	2.352	2.400	2.448	<span style="border: 1px solid black; padding: 0 2px;">2.328</span>	2.400	<span style="border: 1px solid black; padding: 0 2px;">2.472</span>						1.60	<span style="border: 1px solid black; padding: 0 2px;">1.6</span>	
R1514x025B	2.450	2.500	2.550	<span style="border: 1px solid black; padding: 0 2px;">2.425</span>	2.500	<span style="border: 1px solid black; padding: 0 2px;">2.575</span>						1.50	<span style="border: 1px solid black; padding: 0 2px;">1.5</span>	
R1514x026B	2.548	2.600	2.652	<span style="border: 1px solid black; padding: 0 2px;">2.522</span>	2.600	<span style="border: 1px solid black; padding: 0 2px;">2.678</span>						1.40	<span style="border: 1px solid black; padding: 0 2px;">1.4</span>	
R1514x027B	2.646	2.700	2.754	<span style="border: 1px solid black; padding: 0 2px;">2.619</span>	2.700	<span style="border: 1px solid black; padding: 0 2px;">2.781</span>						1.30	<span style="border: 1px solid black; padding: 0 2px;">1.3</span>	
R1514x028B	2.744	2.800	2.856	<span style="border: 1px solid black; padding: 0 2px;">2.716</span>	2.800	<span style="border: 1px solid black; padding: 0 2px;">2.884</span>						1.20	<span style="border: 1px solid black; padding: 0 2px;">1.2</span>	
R1514x029B	2.842	2.900	2.958	<span style="border: 1px solid black; padding: 0 2px;">2.813</span>	2.900	<span style="border: 1px solid black; padding: 0 2px;">2.987</span>						1.10	<span style="border: 1px solid black; padding: 0 2px;">1.1</span>	
R1514x030B	2.940	3.000	3.060	<span style="border: 1px solid black; padding: 0 2px;">2.910</span>	3.000	<span style="border: 1px solid black; padding: 0 2px;">3.090</span>	120	<span style="border: 1px solid black; padding: 0 2px;">120</span>	10	<span style="border: 1px solid black; padding: 0 2px;">25</span>	1.00	<span style="border: 1px solid black; padding: 0 2px;">1.0</span>		
R1514x031B	3.038	3.100	3.162	<span style="border: 1px solid black; padding: 0 2px;">3.007</span>	3.100	<span style="border: 1px solid black; padding: 0 2px;">3.193</span>					0.90	<span style="border: 1px solid black; padding: 0 2px;">0.9</span>		
R1514x032B	3.136	3.200	3.264	<span style="border: 1px solid black; padding: 0 2px;">3.104</span>	3.200	<span style="border: 1px solid black; padding: 0 2px;">3.296</span>					0.80	<span style="border: 1px solid black; padding: 0 2px;">0.8</span>		
R1514x033B	3.234	3.300	3.366	<span style="border: 1px solid black; padding: 0 2px;">3.201</span>	3.300	<span style="border: 1px solid black; padding: 0 2px;">3.399</span>					0.70	<span style="border: 1px solid black; padding: 0 2px;">0.7</span>		
R1514x034B	3.332	3.400	3.468	<span style="border: 1px solid black; padding: 0 2px;">3.298</span>	3.400	<span style="border: 1px solid black; padding: 0 2px;">3.502</span>					0.60	<span style="border: 1px solid black; padding: 0 2px;">0.7</span>		
R1514x035B	3.430	3.500	3.570	<span style="border: 1px solid black; padding: 0 2px;">3.395</span>	3.500	<span style="border: 1px solid black; padding: 0 2px;">3.605</span>					0.50	<span style="border: 1px solid black; padding: 0 2px;">0.6</span>		
R1514x036B	3.528	3.600	3.672	<span style="border: 1px solid black; padding: 0 2px;">3.492</span>	3.600	<span style="border: 1px solid black; padding: 0 2px;">3.708</span>					0.40	<span style="border: 1px solid black; padding: 0 2px;">0.6</span>		
R1514x037B	3.626	3.700	3.774	<span style="border: 1px solid black; padding: 0 2px;">3.589</span>	3.700	<span style="border: 1px solid black; padding: 0 2px;">3.811</span>					0.35	0.60	<span style="border: 1px solid black; padding: 0 2px;">0.60</span>	
R1514x038B	3.724	3.800	3.876	<span style="border: 1px solid black; padding: 0 2px;">3.686</span>	3.800	<span style="border: 1px solid black; padding: 0 2px;">3.914</span>								
R1514x039B	3.822	3.900	3.978	<span style="border: 1px solid black; padding: 0 2px;">3.783</span>	3.900	<span style="border: 1px solid black; padding: 0 2px;">4.017</span>								
R1514x040B	3.920	4.000	4.080	<span style="border: 1px solid black; padding: 0 2px;">3.880</span>	4.000	<span style="border: 1px solid black; padding: 0 2px;">4.120</span>								
R1514x041B	4.018	4.100	4.182	<span style="border: 1px solid black; padding: 0 2px;">3.977</span>	4.100	<span style="border: 1px solid black; padding: 0 2px;">4.223</span>								
R1514x042B	4.116	4.200	4.284	<span style="border: 1px solid black; padding: 0 2px;">4.074</span>	4.200	<span style="border: 1px solid black; padding: 0 2px;">4.326</span>								
R1514x043B	4.214	4.300	4.386	<span style="border: 1px solid black; padding: 0 2px;">4.171</span>	4.300	<span style="border: 1px solid black; padding: 0 2px;">4.429</span>								
R1514x044B	4.312	4.400	4.488	<span style="border: 1px solid black; padding: 0 2px;">4.268</span>	4.400	<span style="border: 1px solid black; padding: 0 2px;">4.532</span>								
R1514x045B	4.410	4.500	4.590	<span style="border: 1px solid black; padding: 0 2px;">4.365</span>	4.500	<span style="border: 1px solid black; padding: 0 2px;">4.635</span>								
R1514x046B	4.508	4.600	4.692	<span style="border: 1px solid black; padding: 0 2px;">4.462</span>	4.600	<span style="border: 1px solid black; padding: 0 2px;">4.738</span>								
R1514x047B	4.606	4.700	4.794	<span style="border: 1px solid black; padding: 0 2px;">4.559</span>	4.700	<span style="border: 1px solid black; padding: 0 2px;">4.841</span>								
R1514x048B	4.704	4.800	4.896	<span style="border: 1px solid black; padding: 0 2px;">4.656</span>	4.800	<span style="border: 1px solid black; padding: 0 2px;">4.944</span>								
R1514x049B	4.802	4.900	4.998	<span style="border: 1px solid black; padding: 0 2px;">4.753</span>	4.900	<span style="border: 1px solid black; padding: 0 2px;">5.047</span>	0.25	0.40	<span style="border: 1px solid black; padding: 0 2px;">0.50</span>					

R1514xxxxB (-AE)

(Ta=25°C)

Product Name	V <sub>OUT</sub> [V]						I <sub>OUT</sub> [mA]				ΔV <sub>OUT</sub> /ΔI <sub>OUT</sub> [mV]	V <sub>DIF</sub> [V]		
	Ta = 25°C			-40°C ≤ Ta ≤ 105°C			Ta = 25°C	-40°C ≤ Ta ≤ 105°C				TYP.	Ta = 25°C	-40°C ≤ Ta ≤ 105°C
	MIN.	TYP.	MAX.	MIN.	TYP.	MAX.	MIN.	MIN.	TYP.	MAX.	MAX.		MAX.	
R1514x050B	4.900	5.000	5.100	4.850	5.000	5.150	150	150	20	35	0.20	0.35	0.40	
R1514x051B	4.998	5.100	5.202	4.947	5.100	5.253								
R1514x052B	5.096	5.200	5.304	5.044	5.200	5.356								
R1514x053B	5.194	5.300	5.406	5.141	5.300	5.459								
R1514x054B	5.292	5.400	5.508	5.238	5.400	5.562								
R1514x055B	5.390	5.500	5.610	5.335	5.500	5.665								
R1514x056B	5.488	5.600	5.712	5.432	5.600	5.768								
R1514x057B	5.586	5.700	5.814	5.529	5.700	5.871								
R1514x058B	5.684	5.800	5.916	5.626	5.800	5.974								
R1514x059B	5.782	5.900	6.018	5.723	5.900	6.077								
R1514x060B	5.880	6.000	6.120	5.820	6.000	6.180								
R1514x061B	5.978	6.100	6.222	5.917	6.100	6.283								
R1514x062B	6.076	6.200	6.324	6.014	6.200	6.386								
R1514x063B	6.174	6.300	6.426	6.111	6.300	6.489								
R1514x064B	6.272	6.400	6.528	6.208	6.400	6.592								
R1514x065B	6.370	6.500	6.630	6.305	6.500	6.695								
R1514x066B	6.468	6.600	6.732	6.402	6.600	6.798								
R1514x067B	6.566	6.700	6.834	6.499	6.700	6.901								
R1514x068B	6.664	6.800	6.936	6.596	6.800	7.004								
R1514x069B	6.762	6.900	7.038	6.693	6.900	7.107								
R1514x070B	6.860	7.000	7.140	6.790	7.000	7.210								
R1514x071B	6.958	7.100	7.242	6.887	7.100	7.313								
R1514x072B	7.056	7.200	7.344	6.984	7.200	7.416								
R1514x073B	7.154	7.300	7.446	7.081	7.300	7.519								
R1514x074B	7.252	7.400	7.548	7.178	7.400	7.622								
R1514x075B	7.350	7.500	7.650	7.275	7.500	7.725								
R1514x076B	7.448	7.600	7.752	7.372	7.600	7.828								
R1514x077B	7.546	7.700	7.854	7.469	7.700	7.931								
R1514x078B	7.644	7.800	7.956	7.566	7.800	8.034								
R1514x079B	7.742	7.900	8.058	7.663	7.900	8.137								
R1514x080B	7.840	8.000	8.160	7.760	8.000	8.240								
R1514x081B	7.938	8.100	8.262	7.857	8.100	8.343								
R1514x082B	8.036	8.200	8.364	7.954	8.200	8.446								
R1514x083B	8.134	8.300	8.466	8.051	8.300	8.549								
R1514x084B	8.232	8.400	8.568	8.148	8.400	8.652								
R1514x085B	8.330	8.500	8.670	8.245	8.500	8.755								
R1514x086B	8.428	8.600	8.772	8.342	8.600	8.858								
R1514x087B	8.526	8.700	8.874	8.439	8.700	8.961								
R1514x088B	8.624	8.800	8.976	8.536	8.800	9.064								
R1514x089B	8.722	8.900	9.078	8.633	8.900	9.167								

# R1514x

NO. EC-152-160930

R1514xxxxB (-AE)

(Ta = 25°C)

Product Name	V <sub>OUT</sub> [V]						I <sub>OUT</sub> [mA]		ΔV <sub>OUT</sub> /ΔI <sub>OUT</sub> [mV]		V <sub>DIF</sub> [V]		
	Ta = 25°C			-40°C ≤ Ta ≤ 105°C			Ta = 25°C	-40°C ≤ Ta ≤ 105°C			TYP.	Ta = 25°C	-40°C ≤ Ta ≤ 105°C
	MIN.	TYP.	MAX.	MIN.	TYP.	MAX.	MIN.	MIN.	TYP.	MAX.		MAX.	MAX.
R1514x090B	8.820	9.000	9.180	8.730	9.000	9.270	150	150	20	35	0.20	0.35	0.40
R1514x091B	8.918	9.100	9.282	8.827	9.100	9.373							
R1514x092B	9.016	9.200	9.384	8.924	9.200	9.476							
R1514x093B	9.114	9.300	9.486	9.021	9.300	9.579							
R1514x094B	9.212	9.400	9.588	9.118	9.400	9.682							
R1514x095B	9.310	9.500	9.690	9.215	9.500	9.785							
R1514x096B	9.408	9.600	9.792	9.312	9.600	9.888							
R1514x097B	9.506	9.700	9.894	9.409	9.700	9.991							
R1514x098B	9.604	9.800	9.996	9.506	9.800	10.094							
R1514x099B	9.702	9.900	10.098	9.603	9.900	10.197							
R1514x100B	9.800	10.000	10.200	9.700	10.000	10.300							
R1514x101B	9.898	10.100	10.302	9.797	10.100	10.403							
R1514x102B	9.996	10.200	10.404	9.894	10.200	10.506							
R1514x103B	10.094	10.300	10.506	9.991	10.300	10.609							
R1514x104B	10.192	10.400	10.608	10.088	10.400	10.712							
R1514x105B	10.290	10.500	10.710	10.185	10.500	10.815							
R1514x106B	10.388	10.600	10.812	10.282	10.600	10.918							
R1514x107B	10.486	10.700	10.914	10.379	10.700	11.021							
R1514x108B	10.584	10.800	11.016	10.476	10.800	11.124							
R1514x109B	10.682	10.900	11.118	10.573	10.900	11.227							
R1514x110B	10.780	11.000	11.220	10.670	11.000	11.330							
R1514x111B	10.878	11.100	11.322	10.767	11.100	11.433							
R1514x112B	10.976	11.200	11.424	10.864	11.200	11.536							
R1514x113B	11.074	11.300	11.526	10.961	11.300	11.639							
R1514x114B	11.172	11.400	11.628	11.058	11.400	11.742							
R1514x115B	11.270	11.500	11.730	11.155	11.500	11.845							
R1514x116B	11.368	11.600	11.832	11.252	11.600	11.948							
R1514x117B	11.466	11.700	11.934	11.349	11.700	12.051							
R1514x118B	11.564	11.800	12.036	11.446	11.800	12.154							
R1514x119B	11.662	11.900	12.138	11.543	11.900	12.257							
R1514x120B	11.760	12.000	12.240	11.640	12.000	12.360							



## R1514xxxxB (-JE)

(-40°C ≤ Ta ≤ 105°C)

Symbol	Item	Conditions	Min.	Typ.	Max.	Unit
I <sub>SS</sub>	Supply Current	V <sub>IN</sub> = V <sub>OUT</sub> + 3.0 V, I <sub>OUT</sub> = 0 mA		9	20	μA
I <sub>standby</sub>	Standby Current	V <sub>IN</sub> = 36 V, V <sub>CE</sub> = 0 V		0.1	1.0	μA
V <sub>OUT</sub>	Output Voltage	V <sub>IN</sub> = V <sub>OUT</sub> + 3.0 V, I <sub>OUT</sub> = 1 mA	Ta = 25°C			
			-40°C ≤ Ta ≤ 105°C		x 0.98	x 1.02
I <sub>OUT</sub>	Output Current	V <sub>IN</sub> = V <sub>OUT</sub> + 3.0 V	Refer to the <i>Product-specific Electrical Characteristics</i>			
ΔV <sub>OUT</sub> /ΔI <sub>OUT</sub>	Load Regulation	V <sub>IN</sub> = V <sub>OUT</sub> + 3.0 V, 1 mA ≤ I <sub>OUT</sub> ≤ 40 mA				
ΔV <sub>OUT</sub> /ΔV <sub>IN</sub>	Line Regulation	V <sub>OUT</sub> + 1.5 V ≤ V <sub>IN</sub> ≤ 36 V, I <sub>OUT</sub> = 1 mA		0.05	0.20	%/V
V <sub>DIF</sub>	Dropout Voltage	I <sub>OUT</sub> = 20 mA	Refer to the <i>Product-specific Electrical Characteristics</i>			
I <sub>SC</sub>	Short Current Limit	V <sub>OUT</sub> = 0 V		50		mA
V <sub>CEH</sub>	CE Input Voltage "H"		1.5		V <sub>IN</sub>	V
V <sub>CEL</sub>	CE Input Voltage "L"		0.0		0.3	V
T <sub>TSD</sub>	Thermal Shutdown Temperature	Junction Temperature	150	160		°C
T <sub>TSR</sub>	Thermal Shutdown Released Temperature	Junction Temperature	110	130		°C

# R1514x

NO. EC-152-160930

## Product-specific Electrical Characteristics

R1514xxxxB (-JE)

(-40°C ≤ Ta ≤ 105°C)

Product Name	V <sub>OUT</sub> [V]						I <sub>OUT</sub> [mA]		ΔV <sub>OUT</sub> /ΔI <sub>OUT</sub> [mV]		V <sub>DIF</sub> [V]			
	Ta = 25°C			-40°C ≤ Ta ≤ 105°C			Ta = 25°C	-40°C ≤ Ta ≤ 105°C			TYP.	Ta = 25°C	-40°C ≤ Ta ≤ 105°C	
	MIN.	TYP.	MAX.	MIN.	TYP.	MAX.	MIN.	MIN.	TYP.	MAX.		MAX.		
R1514x020B	1.960	2.000	2.040	1.940	2.000	2.060	100	90	10	25	-	2.00	2.0	
R1514x021B	2.058	2.100	2.142	2.037	2.100	2.163						1.90	1.9	
R1514x022B	2.156	2.200	2.244	2.134	2.200	2.266						1.80	1.8	
R1514x023B	2.254	2.300	2.346	2.231	2.300	2.369						1.70	1.7	
R1514x024B	2.352	2.400	2.448	2.328	2.400	2.472						1.60	1.6	
R1514x025B	2.450	2.500	2.550	2.425	2.500	2.575						1.50	1.5	
R1514x026B	2.548	2.600	2.652	2.522	2.600	2.678						1.40	1.4	
R1514x027B	2.646	2.700	2.754	2.619	2.700	2.781						1.30	1.3	
R1514x028B	2.744	2.800	2.856	2.716	2.800	2.884						1.20	1.2	
R1514x029B	2.842	2.900	2.958	2.813	2.900	2.987						1.10	1.1	
R1514x030B	2.940	3.000	3.060	2.910	3.000	3.090	120	120	10	25	-	1.00	1.0	
R1514x031B	3.038	3.100	3.162	3.007	3.100	3.193						0.90	0.9	
R1514x032B	3.136	3.200	3.264	3.104	3.200	3.296						0.80	0.8	
R1514x033B	3.234	3.300	3.366	3.201	3.300	3.399						0.70	0.7	
R1514x034B	3.332	3.400	3.468	3.298	3.400	3.502						0.60	0.7	
R1514x035B	3.430	3.500	3.570	3.395	3.500	3.605						0.50	0.6	
R1514x036B	3.528	3.600	3.672	3.492	3.600	3.708						0.40	0.6	
R1514x037B	3.626	3.700	3.774	3.589	3.700	3.811						0.35	0.60	0.60
R1514x038B	3.724	3.800	3.876	3.686	3.800	3.914								
R1514x039B	3.822	3.900	3.978	3.783	3.900	4.017								
R1514x040B	3.920	4.000	4.080	3.880	4.000	4.120	0.25	0.40	0.50					
R1514x041B	4.018	4.100	4.182	3.977	4.100	4.223								
R1514x042B	4.116	4.200	4.284	4.074	4.200	4.326								
R1514x043B	4.214	4.300	4.386	4.171	4.300	4.429								
R1514x044B	4.312	4.400	4.488	4.268	4.400	4.532								
R1514x045B	4.410	4.500	4.590	4.365	4.500	4.635								
R1514x046B	4.508	4.600	4.692	4.462	4.600	4.738								
R1514x047B	4.606	4.700	4.794	4.559	4.700	4.841								
R1514x048B	4.704	4.800	4.896	4.656	4.800	4.944								
R1514x049B	4.802	4.900	4.998	4.753	4.900	5.047								

R1514xxxxB (-JE)

(-40°C ≤ Ta ≤ 105°C)

Product Name	V <sub>OUT</sub> [V]						I <sub>OUT</sub> [mA]				ΔV <sub>OUT</sub> /ΔI <sub>OUT</sub> [mV]	V <sub>DIF</sub> [V]		
	Ta = 25°C			-40°C ≤ Ta ≤ 105°C			Ta = 25°C	-40°C ≤ Ta ≤ 105°C				TYP.	Ta = 25°C	-40°C ≤ Ta ≤ 105°C
	MIN.	TYP.	MAX.	MIN.	TYP.	MAX.	MIN.	MIN.	TYP.	MAX.	MAX.		MAX.	
R1514x050B	4.900	5.000	5.100	4.850	5.000	5.150	150	150	20	35	0.20	0.35	0.40	
R1514x051B	4.998	5.100	5.202	4.947	5.100	5.253								
R1514x052B	5.096	5.200	5.304	5.044	5.200	5.356								
R1514x053B	5.194	5.300	5.406	5.141	5.300	5.459								
R1514x054B	5.292	5.400	5.508	5.238	5.400	5.562								
R1514x055B	5.390	5.500	5.610	5.335	5.500	5.665								
R1514x056B	5.488	5.600	5.712	5.432	5.600	5.768								
R1514x057B	5.586	5.700	5.814	5.529	5.700	5.871								
R1514x058B	5.684	5.800	5.916	5.626	5.800	5.974								
R1514x059B	5.782	5.900	6.018	5.723	5.900	6.077								
R1514x060B	5.880	6.000	6.120	5.820	6.000	6.180								
R1514x061B	5.978	6.100	6.222	5.917	6.100	6.283								
R1514x062B	6.076	6.200	6.324	6.014	6.200	6.386								
R1514x063B	6.174	6.300	6.426	6.111	6.300	6.489								
R1514x064B	6.272	6.400	6.528	6.208	6.400	6.592								
R1514x065B	6.370	6.500	6.630	6.305	6.500	6.695								
R1514x066B	6.468	6.600	6.732	6.402	6.600	6.798								
R1514x067B	6.566	6.700	6.834	6.499	6.700	6.901								
R1514x068B	6.664	6.800	6.936	6.596	6.800	7.004								
R1514x069B	6.762	6.900	7.038	6.693	6.900	7.107								
R1514x070B	6.860	7.000	7.140	6.790	7.000	7.210								
R1514x071B	6.958	7.100	7.242	6.887	7.100	7.313								
R1514x072B	7.056	7.200	7.344	6.984	7.200	7.416								
R1514x073B	7.154	7.300	7.446	7.081	7.300	7.519								
R1514x074B	7.252	7.400	7.548	7.178	7.400	7.622								
R1514x075B	7.350	7.500	7.650	7.275	7.500	7.725								
R1514x076B	7.448	7.600	7.752	7.372	7.600	7.828								
R1514x077B	7.546	7.700	7.854	7.469	7.700	7.931								
R1514x078B	7.644	7.800	7.956	7.566	7.800	8.034								
R1514x079B	7.742	7.900	8.058	7.663	7.900	8.137								
R1514x080B	7.840	8.000	8.160	7.760	8.000	8.240								
R1514x081B	7.938	8.100	8.262	7.857	8.100	8.343								
R1514x082B	8.036	8.200	8.364	7.954	8.200	8.446								
R1514x083B	8.134	8.300	8.466	8.051	8.300	8.549								
R1514x084B	8.232	8.400	8.568	8.148	8.400	8.652								
R1514x085B	8.330	8.500	8.670	8.245	8.500	8.755								
R1514x086B	8.428	8.600	8.772	8.342	8.600	8.858								
R1514x087B	8.526	8.700	8.874	8.439	8.700	8.961								
R1514x088B	8.624	8.800	8.976	8.536	8.800	9.064								
R1514x089B	8.722	8.900	9.078	8.633	8.900	9.167								

# R1514x

NO. EC-152-160930

R1514xxxxB (-JE)

(-40°C ≤ Ta ≤ 105°C)

Product Name	V <sub>OUT</sub> [V]						I <sub>OUT</sub> [mA]		ΔV <sub>OUT</sub> /ΔI <sub>OUT</sub> [mV]		V <sub>DIF</sub> [V]		
	Ta = 25°C			-40°C ≤ Ta ≤ 105°C			Ta = 25°C	-40°C ≤ Ta ≤ 105°C			TYP.	Ta = 25°C	-40°C ≤ Ta ≤ 105°C
	MIN.	TYP.	MAX.	MIN.	TYP.	MAX.	MIN.	MIN.	TYP.	MAX.		MAX.	MAX.
R1514x090B	8.820	9.000	9.180	8.730	9.000	9.270	150	150	20	35	0.20	0.35	0.40
R1514x091B	8.918	9.100	9.282	8.827	9.100	9.373							
R1514x092B	9.016	9.200	9.384	8.924	9.200	9.476							
R1514x093B	9.114	9.300	9.486	9.021	9.300	9.579							
R1514x094B	9.212	9.400	9.588	9.118	9.400	9.682							
R1514x095B	9.310	9.500	9.690	9.215	9.500	9.785							
R1514x096B	9.408	9.600	9.792	9.312	9.600	9.888							
R1514x097B	9.506	9.700	9.894	9.409	9.700	9.991							
R1514x098B	9.604	9.800	9.996	9.506	9.800	10.094							
R1514x099B	9.702	9.900	10.098	9.603	9.900	10.197							
R1514x100B	9.800	10.000	10.200	9.700	10.000	10.300							
R1514x101B	9.898	10.100	10.302	9.797	10.100	10.403							
R1514x102B	9.996	10.200	10.404	9.894	10.200	10.506							
R1514x103B	10.094	10.300	10.506	9.991	10.300	10.609							
R1514x104B	10.192	10.400	10.608	10.088	10.400	10.712							
R1514x105B	10.290	10.500	10.710	10.185	10.500	10.815							
R1514x106B	10.388	10.600	10.812	10.282	10.600	10.918							
R1514x107B	10.486	10.700	10.914	10.379	10.700	11.021							
R1514x108B	10.584	10.800	11.016	10.476	10.800	11.124							
R1514x109B	10.682	10.900	11.118	10.573	10.900	11.227							
R1514x110B	10.780	11.000	11.220	10.670	11.000	11.330							
R1514x111B	10.878	11.100	11.322	10.767	11.100	11.433							
R1514x112B	10.976	11.200	11.424	10.864	11.200	11.536							
R1514x113B	11.074	11.300	11.526	10.961	11.300	11.639							
R1514x114B	11.172	11.400	11.628	11.058	11.400	11.742							
R1514x115B	11.270	11.500	11.730	11.155	11.500	11.845							
R1514x116B	11.368	11.600	11.832	11.252	11.600	11.948							
R1514x117B	11.466	11.700	11.934	11.349	11.700	12.051							
R1514x118B	11.564	11.800	12.036	11.446	11.800	12.154							
R1514x119B	11.662	11.900	12.138	11.543	11.900	12.257							
R1514x120B	11.760	12.000	12.240	11.640	12.000	12.360							

## TYPICAL APPLICATION

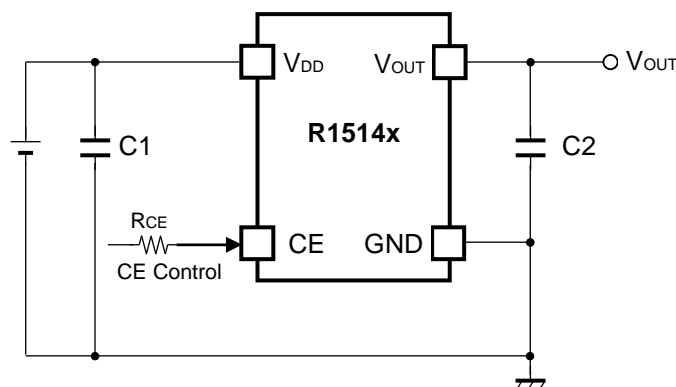

### External Parts Example:

C1 (C <sub>IN</sub> )	0.1 $\mu$ F (Ceramic)
C2 (C <sub>OUT</sub> )	0.1 $\mu$ F (Ceramic)

## TECHNICAL NOTES

### PCB Layout

Ensure the V<sub>DD</sub> and GND lines are sufficiently robust. If their impedance is too high, noise pickup or unstable operation may result. Connect a capacitor with a suitable value between the V<sub>DD</sub> and GND, and as close as possible to the pins.

### Phase Compensation

Phase Compensation of the R1514x has been made internally for stable operation even though the load current would vary. Therefore, without the capacitors, C1 and C2, the output voltage is regulated, however, for more stable operation, use capacitors as C1 and C2. Especially, if the input line is long and impedance is high, C1 is necessary. Moreover, if you use rather large C2, transient response will be improved. Recommended value is in the range from 0.1  $\mu$ F to 10  $\mu$ F. Wiring should be made as short as possible.

Connect the capacitor, C1 between V<sub>DD</sub> pin and GND and C2 between V<sub>OUT</sub> and GND as close as possible.

### Thermal Shutdown

Thermal shutdown function is included in the R1514x, if the junction temperature is more than or equal to 160°C (Typ.), the operation of regulator would stop. After that, when the junction temperature is less than or equal to 130°C (Typ.), the operation of regulator would restart. Unless the cause of rising temperature would remove, the regulator repeats on and off, and output waveform would be like consecutive pulses.

### Chip Enable Circuit

Do not make voltage level of chip enable pin keep floating level, or in between V<sub>CEH</sub> and V<sub>CEL</sub>. Otherwise, the output voltage would be unstable or indefinite, or unexpected current would flow internally.

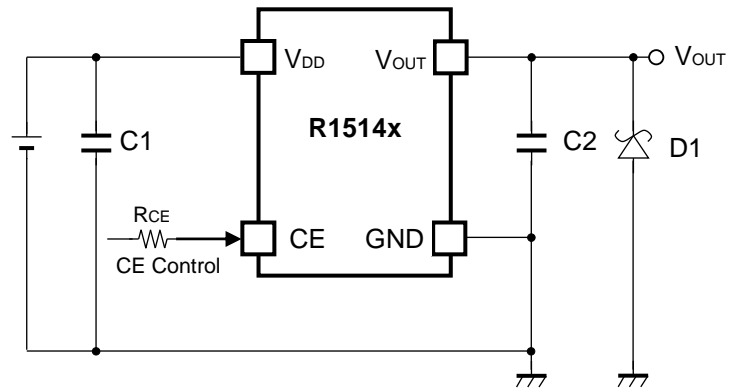
**TYPICAL APPLICATION FOR IC CHIP BREAKDOWN PREVENTION**

When a sudden surge of electrical current travels along the V<sub>OUT</sub> pin and GND due to a short-circuit, electrical resonance of a circuit involving an output capacitor (C2) and a short circuit inductor generates a negative voltage and may damage the device or the load devices. Connecting a schottky diode (D1) between the V<sub>OUT</sub> pin and GND has the effect of preventing damage to them.

## PACKAGE INFORMATION

### POWER DISSIPATION (SOT89-5)

Power Dissipation ( $P_D$ ) depends on conditions of mounting on board. This specification is based on the measurement at the condition below:

#### Measurement Conditions

	High Wattage Land Pattern	Standard Land Pattern
Environment	Mounting on Board (Wind velocity = 0 m/s)	Mounting on Board (Wind velocity = 0 m/s)
Board Material	Glass cloth epoxy plastic (Double sided)	Glass cloth epoxy plastic (Double sided)
Board Dimensions	30 mm × 30 mm × 1.6 mm	50 mm × 50 mm × 1.6 mm
Copper Ratio	Top side : Approx. 20% , Back side : Approx. 100%	Top side : Approx. 10% , Back side : Approx. 100%
Through-hole	φ0.85 mm × 10 pcs	-

#### Measurement Result

( $T_a = 25^\circ\text{C}$ ,  $T_{j\text{max}} = 150^\circ\text{C}$ )

	High Wattage Land Pattern	Standard Land Pattern	Free Air
Power Dissipation	1620 mW	1120 mW	620 mW
Thermal Resistance	77°C/W	111°C/W	200°C/W

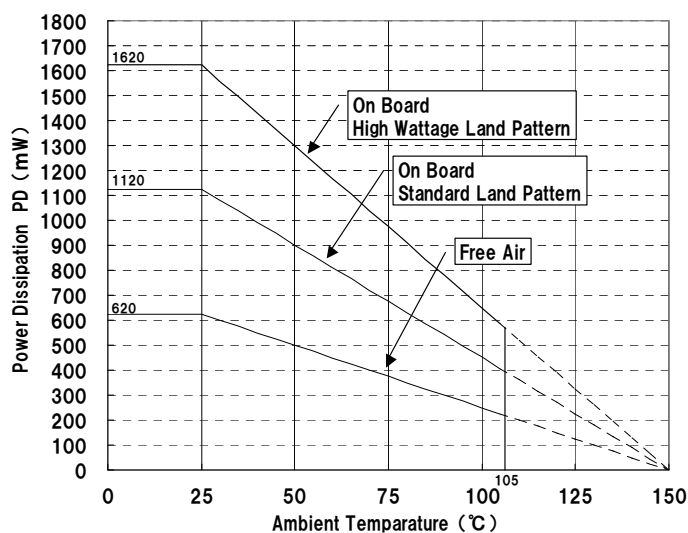

Power Dissipation

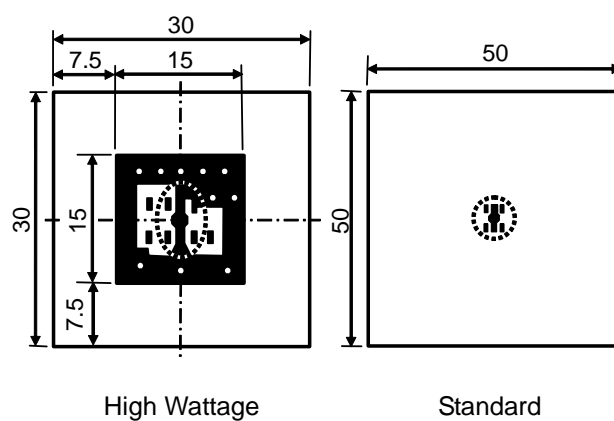

Measurement Board Pattern

○ IC Mount Area (Unit: mm)

**R1514x**

NO. EC-152-160930

**PACKAGE DIMENSIONS (SOT89-5)**

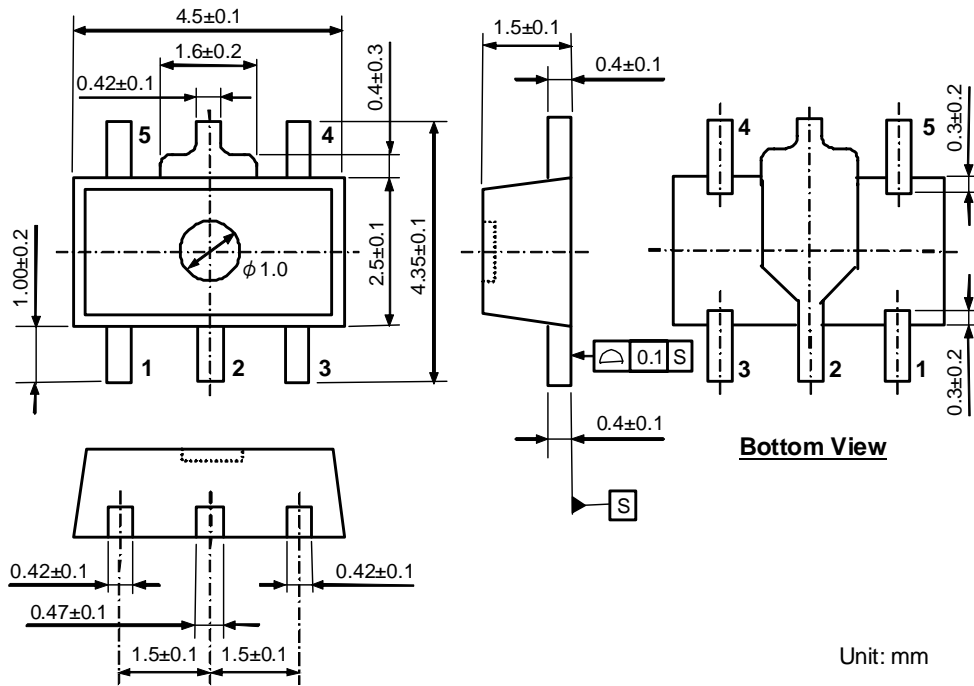

**MARK SPECIFICATION (SOT-89-5)**

①②③④: Product Code ... Refer to R1514H MARK SPECIFICATION TABLE (SOT-89-5)

⑤⑥: Lot Number ... Alphanumeric Serial Number

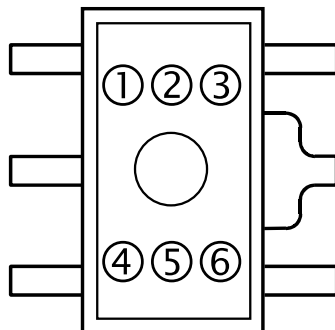



R1514H MARK SPECIFICATION TABLE (SOT-89-5)

Product Name	①②③④	V <sub>out</sub>	Product Name	①②③④	V <sub>out</sub>	Product Name	①②③④	V <sub>out</sub>
R1514H020B	M 0 2 0	2.0 V	R1514H060B	M 0 6 0	6.0 V	R1514H100B	M 1 0 0	10.0 V
R1514H021B	M 0 2 1	2.1 V	R1514H061B	M 0 6 1	6.1 V	R1514H101B	M 1 0 1	10.1 V
R1514H022B	M 0 2 2	2.2 V	R1514H062B	M 0 6 2	6.2 V	R1514H102B	M 1 0 2	10.2 V
R1514H023B	M 0 2 3	2.3 V	R1514H063B	M 0 6 3	6.3 V	R1514H103B	M 1 0 3	10.3 V
R1514H024B	M 0 2 4	2.4 V	R1514H064B	M 0 6 4	6.4 V	R1514H104B	M 1 0 4	10.4 V
R1514H025B	M 0 2 5	2.5 V	R1514H065B	M 0 6 5	6.5 V	R1514H105B	M 1 0 5	10.5 V
R1514H026B	M 0 2 6	2.6 V	R1514H066B	M 0 6 6	6.6 V	R1514H106B	M 1 0 6	10.6 V
R1514H027B	M 0 2 7	2.7 V	R1514H067B	M 0 6 7	6.7 V	R1514H107B	M 1 0 7	10.7 V
R1514H028B	M 0 2 8	2.8 V	R1514H068B	M 0 6 8	6.8 V	R1514H108B	M 1 0 8	10.8 V
R1514H029B	M 0 2 9	2.9 V	R1514H069B	M 0 6 9	6.9 V	R1514H109B	M 1 0 9	10.9 V
R1514H030B	M 0 3 0	3.0 V	R1514H070B	M 0 7 0	7.0 V	R1514H110B	M 1 1 0	11.0 V
R1514H031B	M 0 3 1	3.1 V	R1514H071B	M 0 7 1	7.1 V	R1514H111B	M 1 1 1	11.1 V
R1514H032B	M 0 3 2	3.2 V	R1514H072B	M 0 7 2	7.2 V	R1514H112B	M 1 1 2	11.2 V
R1514H033B	M 0 3 3	3.3 V	R1514H073B	M 0 7 3	7.3 V	R1514H113B	M 1 1 3	11.3 V
R1514H034B	M 0 3 4	3.4 V	R1514H074B	M 0 7 4	7.4 V	R1514H114B	M 1 1 4	11.4 V
R1514H035B	M 0 3 5	3.5 V	R1514H075B	M 0 7 5	7.5 V	R1514H115B	M 1 1 5	11.5 V
R1514H036B	M 0 3 6	3.6 V	R1514H076B	M 0 7 6	7.6 V	R1514H116B	M 1 1 6	11.6 V
R1514H037B	M 0 3 7	3.7 V	R1514H077B	M 0 7 7	7.7 V	R1514H117B	M 1 1 7	11.7 V
R1514H038B	M 0 3 8	3.8 V	R1514H078B	M 0 7 8	7.8 V	R1514H118B	M 1 1 8	11.8 V
R1514H039B	M 0 3 9	3.9 V	R1514H079B	M 0 7 9	7.9 V	R1514H119B	M 1 1 9	11.9 V
R1514H040B	M 0 4 0	4.0 V	R1514H080B	M 0 8 0	8.0 V	R1514H120B	M 1 2 0	12.0 V
R1514H041B	M 0 4 1	4.1 V	R1514H081B	M 0 8 1	8.1 V			
R1514H042B	M 0 4 2	4.2 V	R1514H082B	M 0 8 2	8.2 V			
R1514H043B	M 0 4 3	4.3 V	R1514H083B	M 0 8 3	8.3 V			
R1514H044B	M 0 4 4	4.4 V	R1514H084B	M 0 8 4	8.4 V			
R1514H045B	M 0 4 5	4.5 V	R1514H085B	M 0 8 5	8.5 V			
R1514H046B	M 0 4 6	4.6 V	R1514H086B	M 0 8 6	8.6 V			
R1514H047B	M 0 4 7	4.7 V	R1514H087B	M 0 8 7	8.7 V			
R1514H048B	M 0 4 8	4.8 V	R1514H088B	M 0 8 8	8.8 V			
R1514H049B	M 0 4 9	4.9 V	R1514H089B	M 0 8 9	8.9 V			
R1514H050B	M 0 5 0	5.0 V	R1514H090B	M 0 9 0	9.0 V			
R1514H051B	M 0 5 1	5.1 V	R1514H091B	M 0 9 1	9.1 V			
R1514H052B	M 0 5 2	5.2 V	R1514H092B	M 0 9 2	9.2 V			
R1514H053B	M 0 5 3	5.3 V	R1514H093B	M 0 9 3	9.3 V			
R1514H054B	M 0 5 4	5.4 V	R1514H094B	M 0 9 4	9.4 V			
R1514H055B	M 0 5 5	5.5 V	R1514H095B	M 0 9 5	9.5 V			
R1514H056B	M 0 5 6	5.6 V	R1514H096B	M 0 9 6	9.6 V			
R1514H057B	M 0 5 7	5.7 V	R1514H097B	M 0 9 7	9.7 V			
R1514H058B	M 0 5 8	5.8 V	R1514H098B	M 0 9 8	9.8 V			
R1514H059B	M 0 5 9	5.9 V	R1514H099B	M 0 9 9	9.9 V			

# R1514x

NO. EC-152-160930

## POWER DISSIPATION (HSOP-6J)

The power dissipation of the package is dependent on PCB material, layout, and environmental conditions. The following conditions are used in this measurement.

### Measurement Conditions

	Ultra-high Wattage Land Pattern	Standard Land Pattern
Environment	Mounting on Board (Wind Velocity = 0 m/s)	Mounting on Board (Wind Velocity = 0 m/s)
Board Material	Glass Cloth Epoxy Plastic (Four-Layer Board)	Glass Cloth Epoxy Plastic (Double-sided Board)
Board Dimensions	76.2 mm × 114.3 mm × 0.8 mm	50 mm × 50 mm × 1.6 mm
Copper Ratio	96%	50%
Through-holes	φ 0.3 mm × 28 pcs	φ 0.5 mm × 24 pcs

### Measurement Result

(Ta = 25°C, Tjmax = 150°C)

	Ultra-high Wattage Land Pattern	Standard Land Pattern	Free Air
Power Dissipation	3400 mW	2100 mW	675 mW
Thermal Resistance	37°C/W	59°C/W	185°C/W

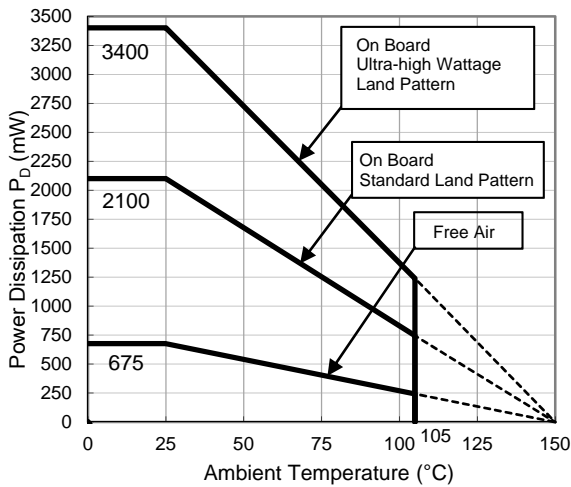

Power Dissipation vs. Ambient Temperature

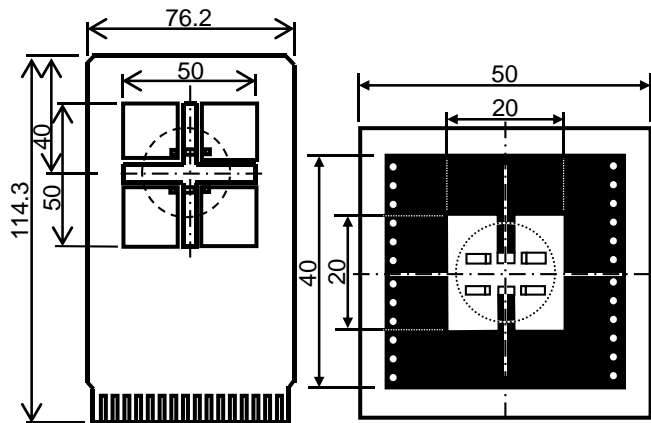

Ultra-high Wattage

Standard

○ IC Mount Area (mm)

Measurement Board Pattern

PACKAGE DIMENSIONS (HSOP-6J)

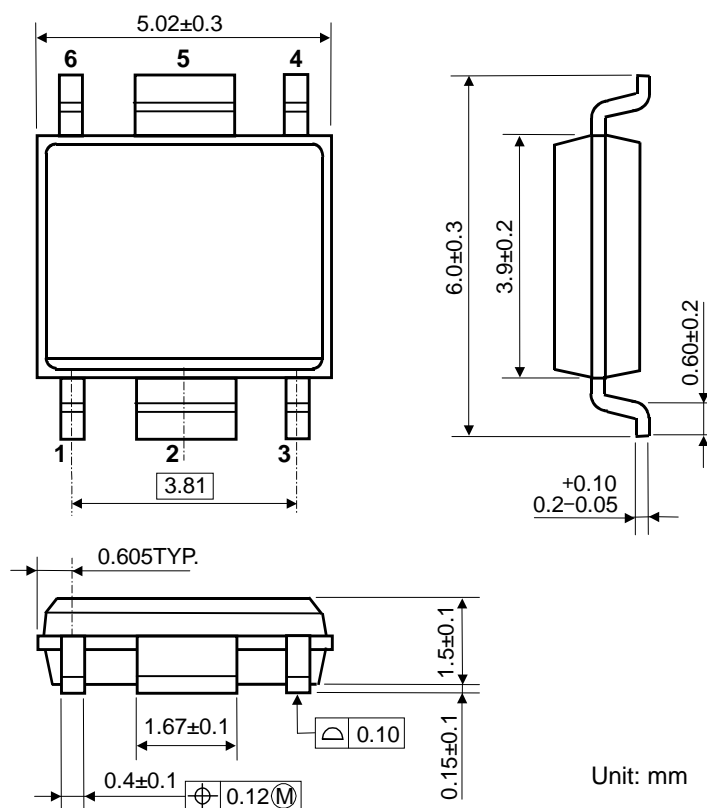

MARK SPECIFICATION (HSOP-6J)

- ①②③④: Product Code ... **Refer to R1514S MARK SPECIFICATION TABLE (HSOP-6J)**
- ⑤⑥: Lot Number ... Alphanumeric Serial Number

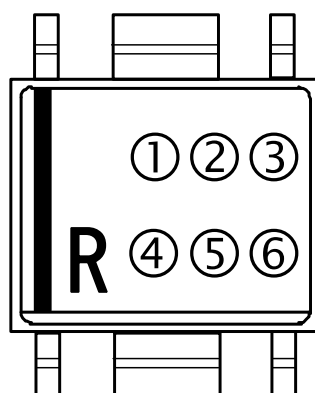

**R1514x**

NO. EC-152-160930

**R1514S MARK SPECIFICATION TABLE (HSOP-6J)**

Product Name	①②③④	V <sub>OUT</sub>
R1514S020B	E 0 2 0	2.0 V
R1514S021B	E 0 2 1	2.1 V
R1514S022B	E 0 2 2	2.2 V
R1514S023B	E 0 2 3	2.3 V
R1514S024B	E 0 2 4	2.4 V
R1514S025B	E 0 2 5	2.5 V
R1514S026B	E 0 2 6	2.6 V
R1514S027B	E 0 2 7	2.7 V
R1514S028B	E 0 2 8	2.8 V
R1514S029B	E 0 2 9	2.9 V
R1514S030B	E 0 3 0	3.0 V
R1514S031B	E 0 3 1	3.1 V
R1514S032B	E 0 3 2	3.2 V
R1514S033B	E 0 3 3	3.3 V
R1514S034B	E 0 3 4	3.4 V
R1514S035B	E 0 3 5	3.5 V
R1514S036B	E 0 3 6	3.6 V
R1514S037B	E 0 3 7	3.7 V
R1514S038B	E 0 3 8	3.8 V
R1514S039B	E 0 3 9	3.9 V
R1514S040B	E 0 4 0	4.0 V
R1514S041B	E 0 4 1	4.1 V
R1514S042B	E 0 4 2	4.2 V
R1514S043B	E 0 4 3	4.3 V
R1514S044B	E 0 4 4	4.4 V
R1514S045B	E 0 4 5	4.5 V
R1514S046B	E 0 4 6	4.6 V
R1514S047B	E 0 4 7	4.7 V
R1514S048B	E 0 4 8	4.8 V
R1514S049B	E 0 4 9	4.9 V
R1514S050B	E 0 5 0	5.0 V
R1514S051B	E 0 5 1	5.1 V
R1514S052B	E 0 5 2	5.2 V
R1514S053B	E 0 5 3	5.3 V
R1514S054B	E 0 5 4	5.4 V
R1514S055B	E 0 5 5	5.5 V
R1514S056B	E 0 5 6	5.6 V
R1514S057B	E 0 5 7	5.7 V
R1514S058B	E 0 5 8	5.8 V
R1514S059B	E 0 5 9	5.9 V

Product Name	①②③④	V <sub>OUT</sub>
R1514S060B	E 0 6 0	6.0 V
R1514S061B	E 0 6 1	6.1 V
R1514S062B	E 0 6 2	6.2 V
R1514S063B	E 0 6 3	6.3 V
R1514S064B	E 0 6 4	6.4 V
R1514S065B	E 0 6 5	6.5 V
R1514S066B	E 0 6 6	6.6 V
R1514S067B	E 0 6 7	6.7 V
R1514S068B	E 0 6 8	6.8 V
R1514S069B	E 0 6 9	6.9 V
R1514S070B	E 0 7 0	7.0 V
R1514S071B	E 0 7 1	7.1 V
R1514S072B	E 0 7 2	7.2 V
R1514S073B	E 0 7 3	7.3 V
R1514S074B	E 0 7 4	7.4 V
R1514S075B	E 0 7 5	7.5 V
R1514S076B	E 0 7 6	7.6 V
R1514S077B	E 0 7 7	7.7 V
R1514S078B	E 0 7 8	7.8 V
R1514S079B	E 0 7 9	7.9 V
R1514S080B	E 0 8 0	8.0 V
R1514S081B	E 0 8 1	8.1 V
R1514S082B	E 0 8 2	8.2 V
R1514S083B	E 0 8 3	8.3 V
R1514S084B	E 0 8 4	8.4 V
R1514S085B	E 0 8 5	8.5 V
R1514S086B	E 0 8 6	8.6 V
R1514S087B	E 0 8 7	8.7 V
R1514S088B	E 0 8 8	8.8 V
R1514S089B	E 0 8 9	8.9 V
R1514S090B	E 0 9 0	9.0 V
R1514S091B	E 0 9 1	9.1 V
R1514S092B	E 0 9 2	9.2 V
R1514S093B	E 0 9 3	9.3 V
R1514S094B	E 0 9 4	9.4 V
R1514S095B	E 0 9 5	9.5 V
R1514S096B	E 0 9 6	9.6 V
R1514S097B	E 0 9 7	9.7 V
R1514S098B	E 0 9 8	9.8 V
R1514S099B	E 0 9 9	9.9 V

Product Name	①②③④	V <sub>OUT</sub>
R1514S100B	E 1 0 0	10.0 V
R1514S101B	E 1 0 1	10.1 V
R1514S102B	E 1 0 2	10.2 V
R1514S103B	E 1 0 3	10.3 V
R1514S104B	E 1 0 4	10.4 V
R1514S105B	E 1 0 5	10.5 V
R1514S106B	E 1 0 6	10.6 V
R1514S107B	E 1 0 7	10.7 V
R1514S108B	E 1 0 8	10.8 V
R1514S109B	E 1 0 9	10.9 V
R1514S110B	E 1 1 0	11.0 V
R1514S111B	E 1 1 1	11.1 V
R1514S112B	E 1 1 2	11.2 V
R1514S113B	E 1 1 3	11.3 V
R1514S114B	E 1 1 4	11.4 V
R1514S115B	E 1 1 5	11.5 V
R1514S116B	E 1 1 6	11.6 V
R1514S117B	E 1 1 7	11.7 V
R1514S118B	E 1 1 8	11.8 V
R1514S119B	E 1 1 9	11.9 V
R1514S120B	E 1 2 0	12.0 V

## TYPICAL CHARACTERISTICS

Note: Typical Characteristics are intended to be used as reference data; they are not guaranteed.

### 1) Output Voltage vs. Output Current (Ta = 25°C)

R1514x020B

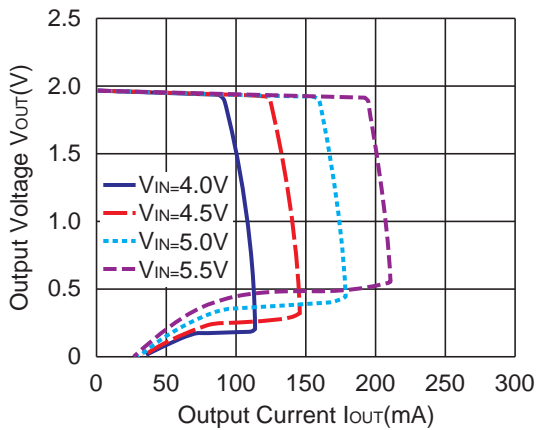

R1514x030B

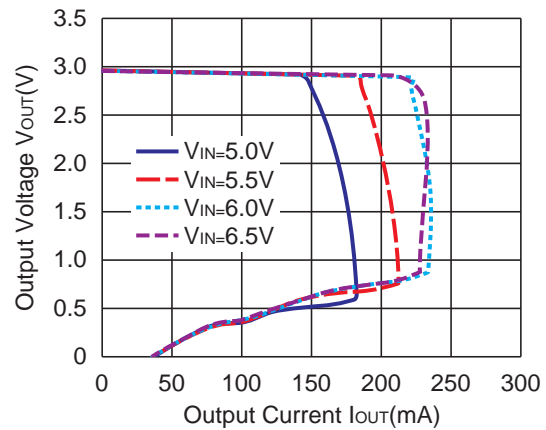

R1514x050B

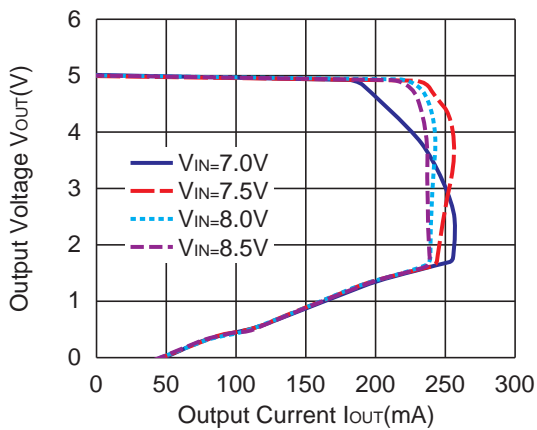

R1514x090B

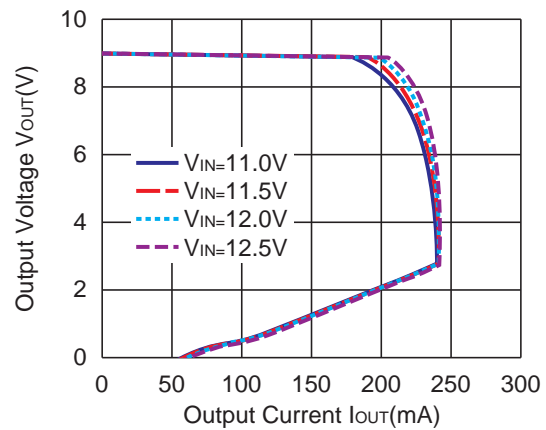

### 2) Output Voltage vs. Input Voltage (Ta = 25°C)

R1514x020B

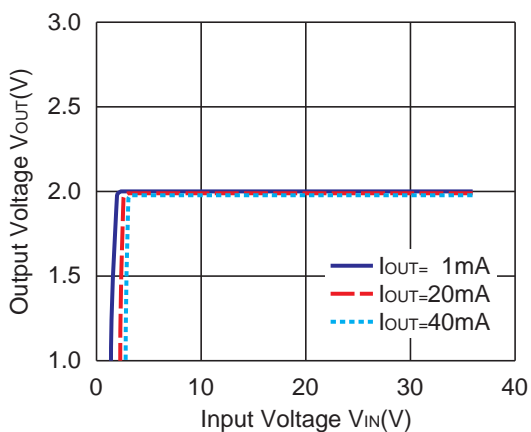

R1514x030B

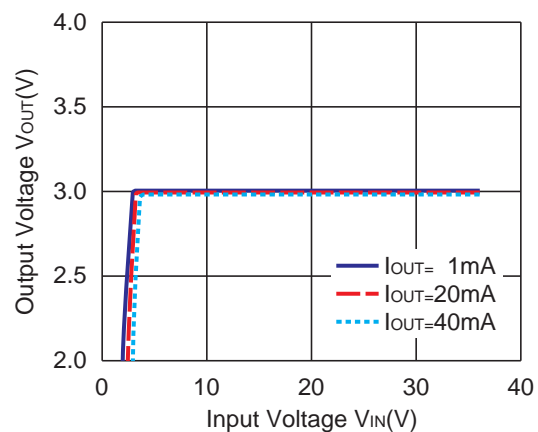

**R1514x050B**

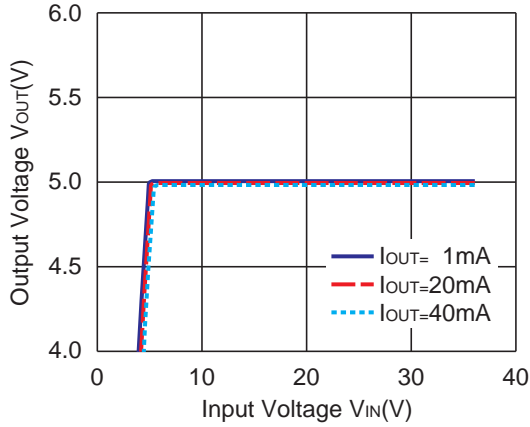

**R1514x090B**

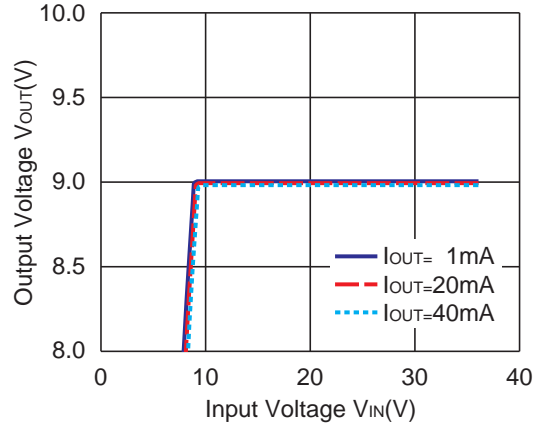

**3) Dropout Voltage vs. Output Current**

**R1514x020B**

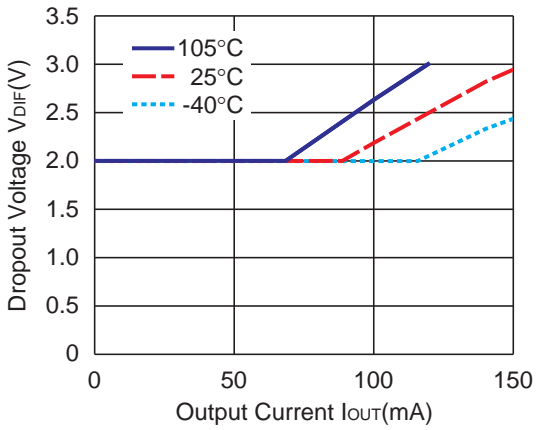

**R1514x030B**

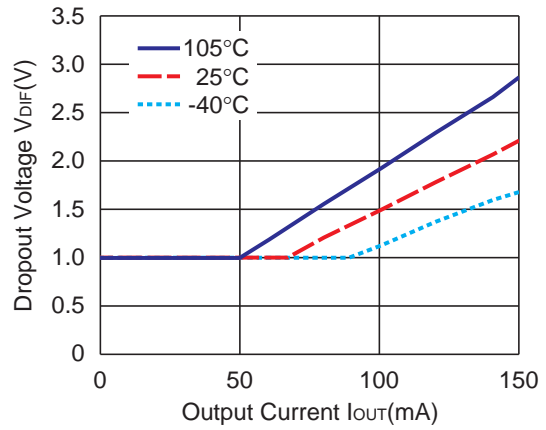

**R1514x050B**

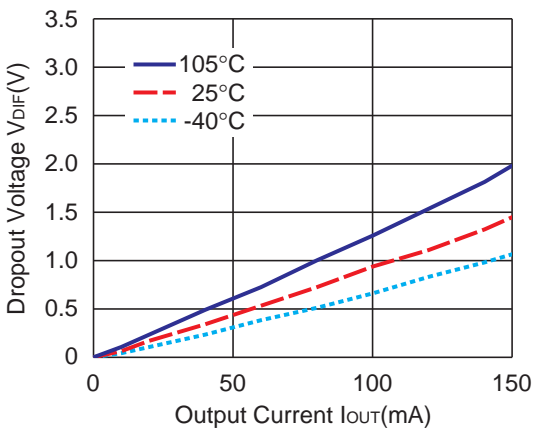

**R1514x090B**

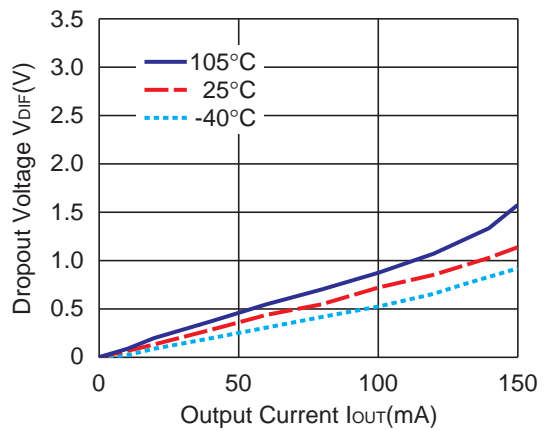

4) Output Voltage vs. Temperature

R1514x020B

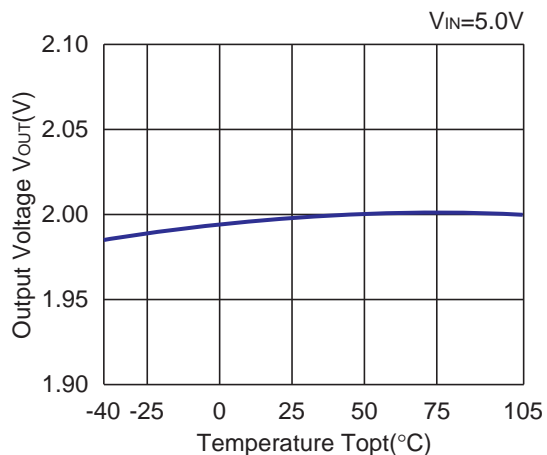

R1514x030B

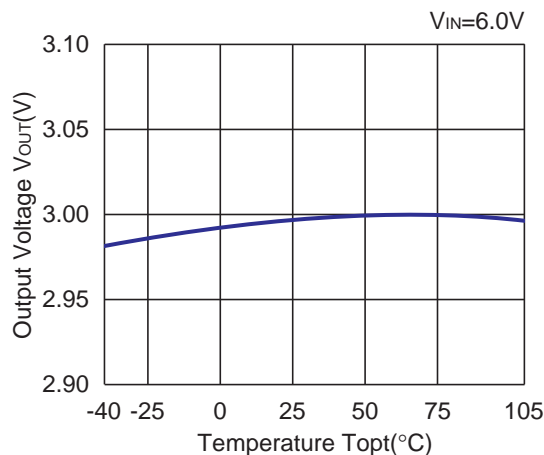

R1514x050B

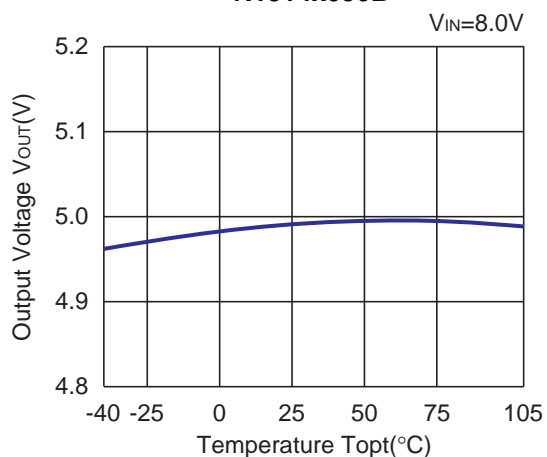

R1514x090B

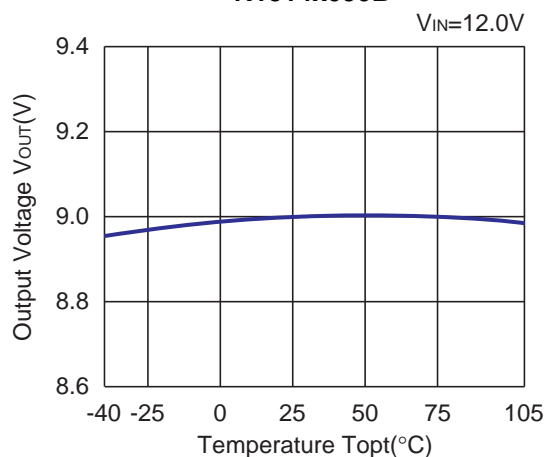

5) Supply Current vs. Input Voltage ( $T_a = 25^{\circ}C$ )

R1514x020B

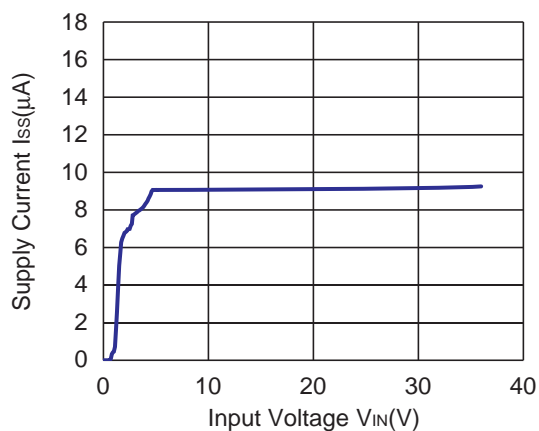

R1514x030B

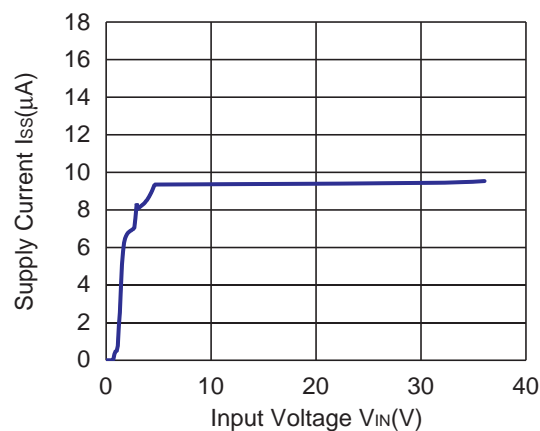

# R1514x

NO. EC-152-160930

### R1514x050B

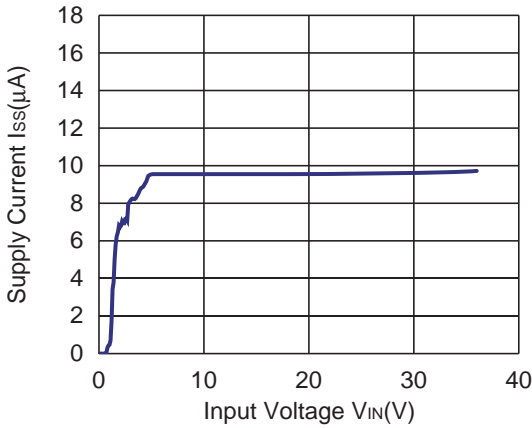

### R1514x090B

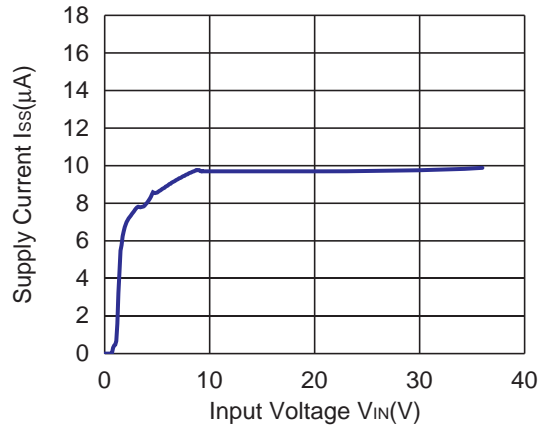

## 6) Supply Current vs. Temperature

### R1514x020B

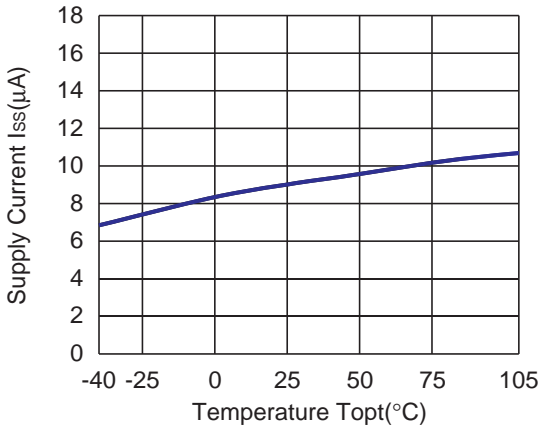

### R1514x030B

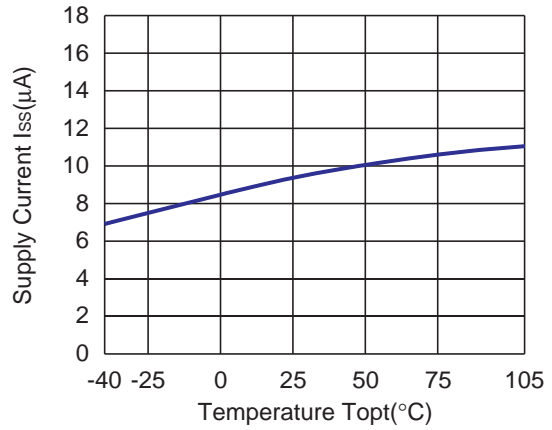

### R1514x050B

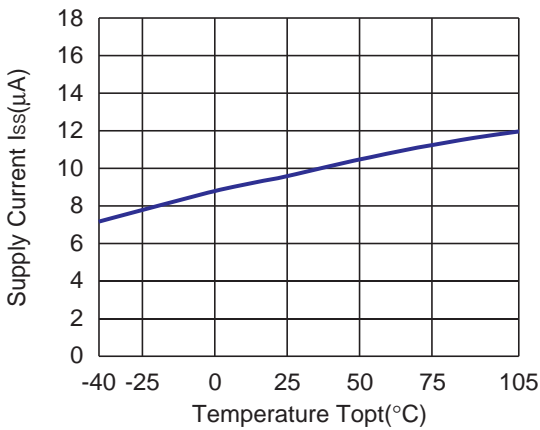

### R1514x090B

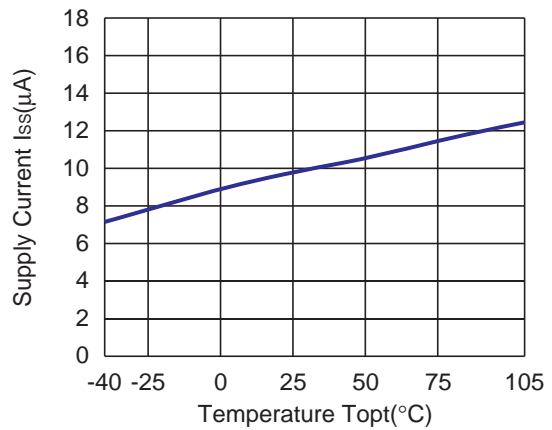



7) Input Transient Response ( $I_{OUT} = 1\text{ mA}$ ,  $t_r = t_f = 50\ \mu\text{s}$ ,  $C_2 = \text{Ceramic } 0.1\ \mu\text{F}$ ,  $T_a = 25^\circ\text{C}$ )

R1514x020B

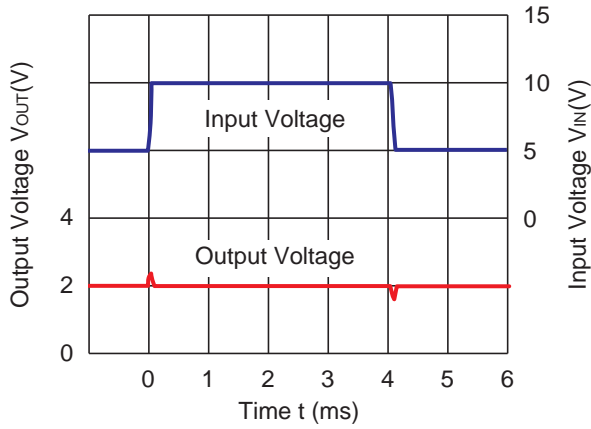

R1514x030B

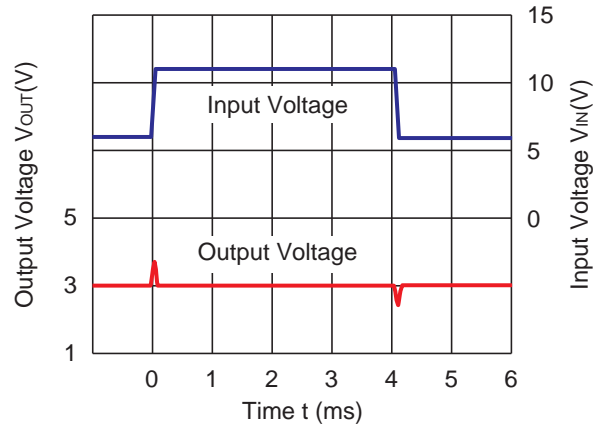

R1514x050B

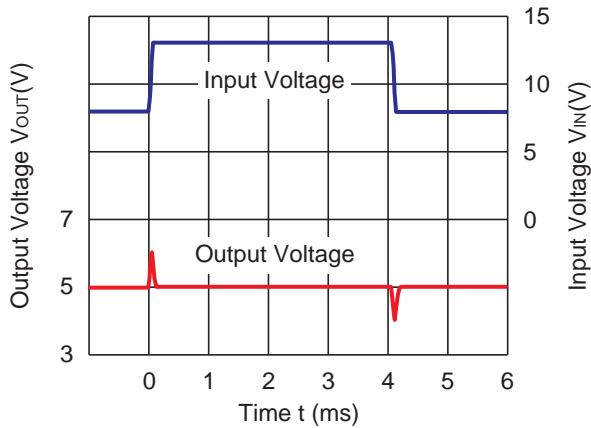

R1514x090B

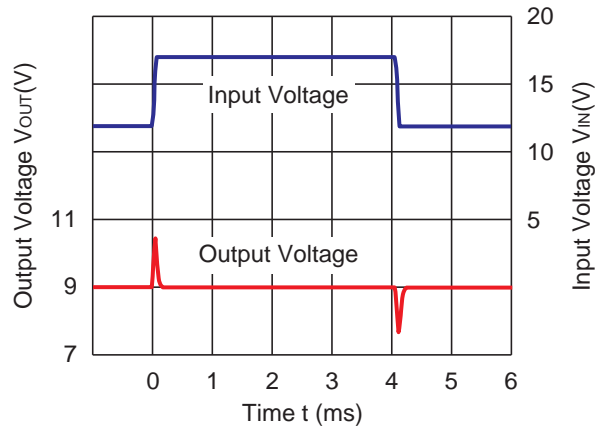

8) Load Transient Response ( $C_2 = \text{Ceramic } 0.1\ \mu\text{F}$ ,  $T_a = 25^\circ\text{C}$ )

R1514x020B

$V_{IN} = 5.0\text{V}$   
 $t_r = t_f = 50\ \mu\text{s}$

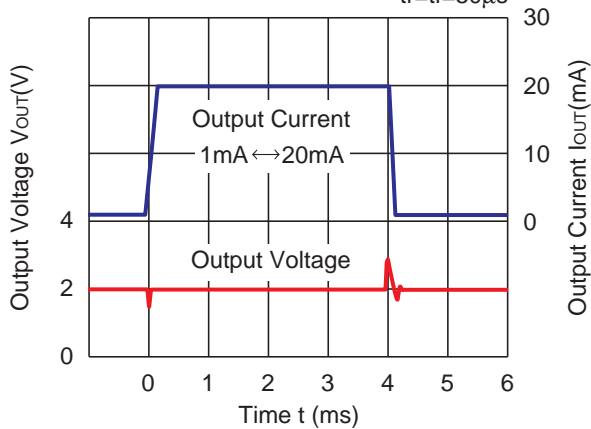

R1514x030B

$V_{IN} = 6.0\text{V}$   
 $t_r = t_f = 50\ \mu\text{s}$

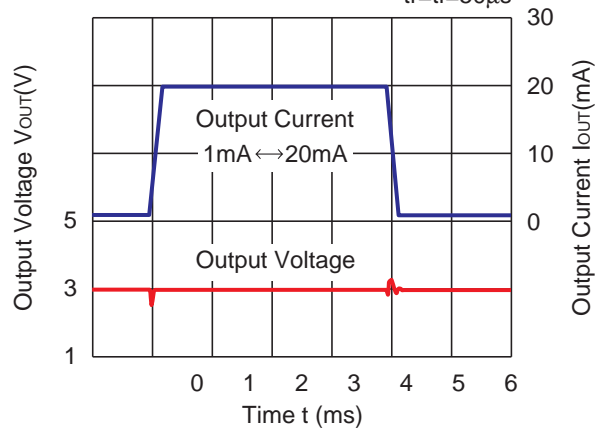

# R1514x

NO. EC-152-160930

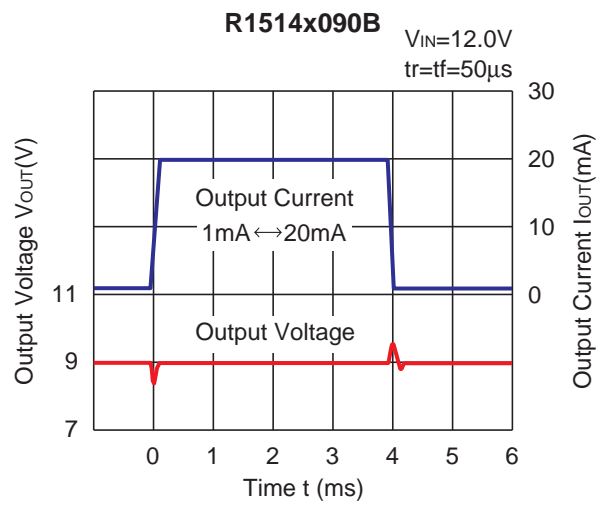
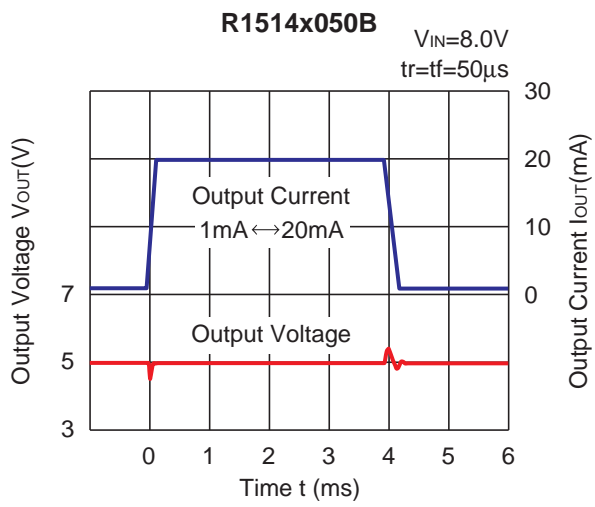



1. The products and the product specifications described in this document are subject to change or discontinuation of production without notice for reasons such as improvement. Therefore, before deciding to use the products, please refer to Ricoh sales representatives for the latest information thereon.
2. The materials in this document may not be copied or otherwise reproduced in whole or in part without prior written consent of Ricoh.
3. Please be sure to take any necessary formalities under relevant laws or regulations before exporting or otherwise taking out of your country the products or the technical information described herein.
4. The technical information described in this document shows typical characteristics of and example application circuits for the products. The release of such information is not to be construed as a warranty of or a grant of license under Ricoh's or any third party's intellectual property rights or any other rights.
5. The products in this document are designed for automotive applications. However, when using the products for automotive applications, please make sure to contact Ricoh sales representative in advance due to confirming the quality level.
6. We are making our continuous effort to improve the quality and reliability of our products, but semiconductor products are likely to fail with certain probability. In order to prevent any injury to persons or damages to property resulting from such failure, customers should be careful enough to incorporate safety measures in their design, such as redundancy feature, fire containment feature and fail-safe feature. We do not assume any liability or responsibility for any loss or damage arising from misuse or inappropriate use of the products.
7. Anti-radiation design is not implemented in the products described in this document.
8. The X-ray exposure can influence functions and characteristics of the products. Confirm the product functions and characteristics in the evaluation stage.
9. WLCSP products should be used in light shielded environments. The light exposure can influence functions and characteristics of the products under operation or storage.
10. There can be variation in the marking when different AOI (Automated Optical Inspection) equipment is used. In the case of recognizing the marking characteristic with AOI, please contact Ricoh sales or our distributor before attempting to use AOI.
11. Please contact Ricoh sales representatives should you have any questions or comments concerning the products or the technical information.



**Ricoh is committed to reducing the environmental loading materials in electrical devices with a view to contributing to the protection of human health and the environment.**

Ricoh has been providing RoHS compliant products since April 1, 2006 and Halogen-free products since April 1, 2012.

**RICOH** RICOH ELECTRONIC DEVICES CO., LTD.

<https://www.e-devices.ricoh.co.jp/en/>

#### Sales & Support Offices

##### **Ricoh Electronic Devices Co., Ltd.**

##### **Shin-Yokohama Office (International Sales)**

2-3, Shin-Yokohama 3-chome, Kohoku-ku, Yokohama-shi, Kanagawa, 222-8530, Japan  
Phone: +81-50-3814-7687 Fax: +81-45-474-0074

##### **Ricoh Americas Holdings, Inc.**

675 Campbell Technology Parkway, Suite 200 Campbell, CA 95008, U.S.A.  
Phone: +1-408-610-3105

##### **Ricoh Europe (Netherlands) B.V.**

##### **Semiconductor Support Centre**

Prof. W.H. Keesomlaan 1, 1183 DJ Amstelveen, The Netherlands  
Phone: +31-20-5474-309

##### **Ricoh International B.V. - German Branch**

##### **Semiconductor Sales and Support Centre**

Oberrather Strasse 6, 40472 Düsseldorf, Germany  
Phone: +49-211-6546-0

##### **Ricoh Electronic Devices Korea Co., Ltd.**

3F, Haesung Bldg, 504, Teheran-ro, Gangnam-gu, Seoul, 135-725, Korea  
Phone: +82-2-2135-5700 Fax: +82-2-2051-5713

##### **Ricoh Electronic Devices Shanghai Co., Ltd.**

Room 403, No.2 Building, No.690 Bibo Road, Pu Dong New District, Shanghai 201203,  
People's Republic of China  
Phone: +86-21-5027-3200 Fax: +86-21-5027-3299

##### **Ricoh Electronic Devices Shanghai Co., Ltd. Shenzhen Branch**

1205, Block D (Jinlong Building), Kingkey 100, Hongbao Road, Luohu District,  
Shenzhen, China  
Phone: +86-755-8348-7600 Ext 225

##### **Ricoh Electronic Devices Co., Ltd.**

##### **Taipei office**

Room 109, 10F-1, No.51, Hengyang Rd., Taipei City, Taiwan (R.O.C.)  
Phone: +886-2-2313-1621/1622 Fax: +886-2-2313-1623

## X-ON Electronics

Largest Supplier of Electrical and Electronic Components

*Click to view similar products for [LDO Voltage Regulators](#) category:*

*Click to view products by [Nisshinbo](#) manufacturer:*

Other Similar products are found below :

[AP7363-SP-13](#) [L79M05TL-E](#) [TCR3DF185,LM\(CT](#) [TCR3DF24,LM\(CT](#) [TCR3DF285,LM\(CT](#) [TCR3DF31,LM\(CT](#) [TCR3DF45,LM\(CT](#)  
[MP2013GQ-33-Z](#) [059985X](#) [NCP4687DH15T1G](#) [701326R](#) [TCR2EN28,LF\(S](#) [NCV8170AXV250T2G](#) [TCR3DF27,LM\(CT](#)  
[TCR3DF19,LM\(CT](#) [TCR3DF125,LM\(CT](#) [TCR2EN18,LF\(S](#) [AP2112R5A-3.3TRG1](#) [AP7315-25W5-7](#) [IFX30081LDVGRNXUMA1](#)  
[NCV47411PAAJR2G](#) [AP2113KTR-G1](#) [AP2111H-1.2TRG1](#) [ZLDO1117QK50TC](#) [AZ1117IH-1.8TRG1](#) [AZ1117ID-ADJTRG1](#)  
[TCR3DG12,LF](#) [MIC5514-3.3YMT-T5](#) [MIC5512-1.2YMT-T5](#) [MIC5317-2.8YM5-T5](#) [SCD7912BTG](#) [NCP154MX180270TAG](#) [SCD33269T-](#)  
[5.0G](#) [NCV8170BMX330TCG](#) [NCV8170AMX120TCG](#) [NCP706ABMX300TAG](#) [NCP153MX330180TCG](#) [NCP114BMX075TCG](#)  
[MC33269T-3.5G](#) [CAT6243-ADJCMT5T](#) [TCR3DG33,LF](#) [AP2127N-1.0TRG1](#) [TCR4DG35,LF](#) [LT1117CST-3.3](#) [TAR5S15U\(TE85L,F\)](#)  
[TAR5S18U\(TE85L,F\)](#) [TCR3UG19A,LF](#) [TCR4DG105,LF](#) [NCV8170AMX360TCG](#) [MIC94310-NYMT-T5](#)