

### 500 mA 36V Input Low Supply Current LDO for Automotive Applications

NO. EC-304-201125

## OUTLINE

R1517x is a CMOS-based LDO that specifically designed for automotive applications featuring 500 mA output current and 36 V input voltage. In addition to a conventional regulator circuit, R1517x consists of a constant slope circuit as a soft-start function, a fold-back protection circuit, a short current limit circuit, and a thermal shutdown circuit. Besides the low supply current by CMOS, the operating temperature is  $-40^{\circ}\text{C}$  to  $125^{\circ}\text{C}$  and the maximum input voltage is 36 V, the R1517x is very suitable for power source of car accessories.

R1517x supports the internal fixed output voltage type of R1517xxxxB/D/E/F, and the output voltage of R1517x001C can adjust the output voltage be set with an external resistor, and the setting range is from 2.5V to Max 20V. As for the soft-start time, R1517x is fixed internal in R1517xxxxB/D/E/F and is set to 120  $\mu\text{s}$  (Typ). And the soft-start time in R1517Jxx1E/F is adjustable by external capacitors. R1517x supports the auto-discharge function at standby in R1517xxxxD/F.

R1517x is available in two packages for ultra-high wattage: HSOP-6J and TO-252-5-P2.

## FEATURES

- Input Voltage Range (Maximum Rating) ..... 3.5 V to 36.0 V (50.0V)
- Operating Temperature Range .....  $-40^{\circ}\text{C}$  to  $125^{\circ}\text{C}$
- Supply Current ..... Typ. 18  $\mu\text{A}$
- Standby Current ..... Typ. 0.1  $\mu\text{A}$
- Dropout Voltage ..... Typ. 0.35 V ( $I_{\text{OUT}} = 500 \text{ mA}$ ,  $V_{\text{OUT}} = 5.0 \text{ V}$ )
- Output Voltage Accuracy .....  $\pm 0.8\%$  ( $V_{\text{OUT}} \leq 5.0 \text{ V}$ )
- Temperature-Drift Coefficient of Output Voltage ..... Typ.  $\pm 60 \text{ ppm}/^{\circ}\text{C}$  ( $-40^{\circ}\text{C} \leq T_a \leq 125^{\circ}\text{C}$ )
- Line Regulation ..... Typ. 0.01%/V
- Packages ..... HSOP-6J, TO-252-5-P2
- Output Voltage Range ..... 2.5 V/2.8 V/3.0 V/3.3 V/3.4 V/5.0 V/ 6.0 V/8.0 V/  
8.5 V/9.0 V  
R1517x001C: Adjustable from 2.5 V to 20.0 V with External  
Resistors.  
Feedback Voltage: 2.5 V
- Built-in Short Current Limit Circuit ..... Typ. 75 mA
- Built-in Fold-Back Protection Circuit ..... Min. 500 mA
- Built-in Thermal Shutdown Circuit ..... Typ.  $160^{\circ}\text{C}$
- Built-in Soft-start Circuit ..... Typ. 120  $\mu\text{s}$   
R1517Jxx1E/F: Adjustable Time Setting with External  
Capacitors.
- Usable Ceramic Capacitors ..... 0.1  $\mu\text{F}$  or more  
R1517x001C: 1.0  $\mu\text{F}$  or more

## APPLICATIONS

- Power source for car accessories including car audio equipment, car navigation system, and ETC system.
- Power source for control units including EV inverter and charge control.

## BLOCK DIAGRAMS

R1517xxxxB

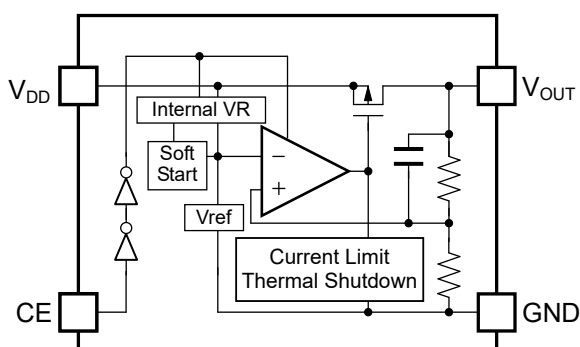

R1517x001C

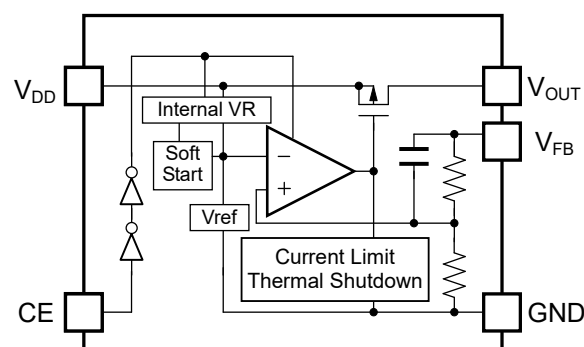

R1517xxxxD

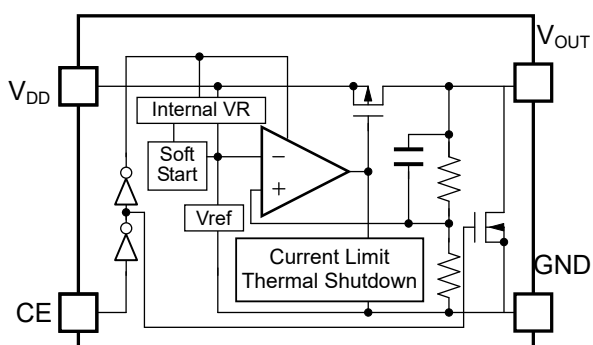

R1517Jxx1E

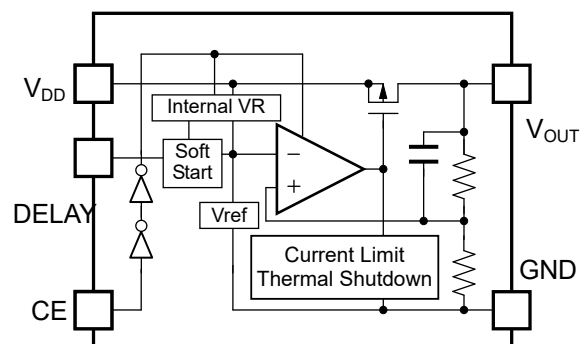

R1517Jxx1F

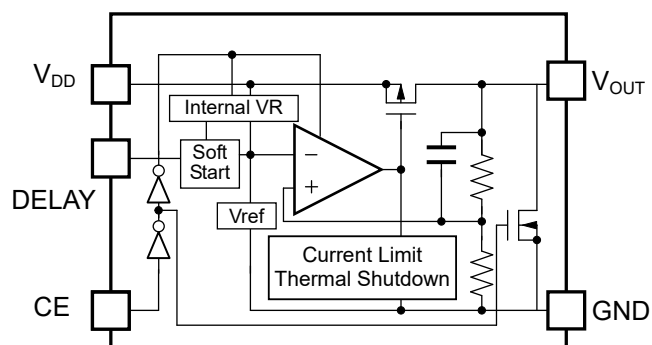

## SELECTION GUIDE

The output voltage, version, and package type for this device can be selected at the user's request.

Product Name	Package	Quantity per Reel	Pb Free	Halogen Free
R1517Sxx2*-E2-#E	HSOP-6J	1,000 pcs	Yes	Yes
R1517S001C-E2-#E				
R1517Jxx1*-T1-#E	TO-252-5-P2	3,000 pcs	Yes	Yes
R1517J001C-T1-#E				

xx: Specify the set output voltage ( $V_{SET}$ )

2.5 V (25) / 2.8 V (28) / 3.0 V (30) / 3.3 V (33) / 3.4 V (34) / 5.0 V (50) / 6.0 V (60) /  
8.0 V (80) / 8.5 V (85) / 9.0 V (90)

Adjustable output voltage setting type is fixed to (00)

**Note: For R1517S001C-E2-#E and R1517J001C-T1-#E (No auto-discharge function)**

\* : Specify the version with desired functions

B: No auto-discharge function

D: Auto-discharge function

E: No auto-discharge function / Adjustable soft-start time setting

F: Auto-discharge function / Adjustable soft-start time setting

**Note: R1517Sxx2\*-E2-#E can provide R1517Sxx2B/D only.**

# : Specify Automotive Class Code

	Operating Temperature Range	Guaranteed Specs Temperature Range	Screening
A	-40°C to 125°C	25°C	High temperature
K	-40°C to 125°C	-40°C to 125°C	High and low temperature

Auto-discharge function quickly lowers the output voltage to 0 V by releasing the electrical charge in the external capacitor when the chip enable signal is switched from the active mode to the standby mode.

## PIN DESCRIPTION

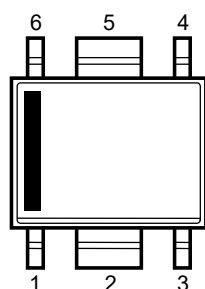

HSOP-6J

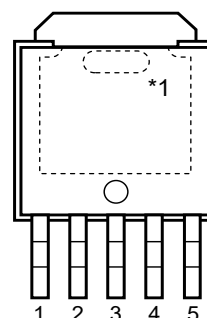

TO-252-5-P2

## HSOP-6J

Pin No.	Symbol	Description	
1	V <sub>DD</sub>	Input Pin	
2	GND	Ground Pin	
3	GND	Ground Pin	R1517Sxx2B/D
	V <sub>FB</sub>	Feedback Pin	R1517S001C
4	CE	Chip Enable Pin, Active-high	
5	GND	Ground Pin	
6	V <sub>OUT</sub>	Output Pin	

## TO-252-5-P2

Pin No.	Symbol	Description	
1	V <sub>DD</sub>	Input Pin	
2	NC	No Connection	R1517Jxx1B/D
	V <sub>FB</sub>	Feedback Pin	R1517J001C
	DELAY	Adjustable Soft-start Time Pin	R1517Jxx1E/F
3	GND	Ground Pin	
4	CE	Chip Enable Pin, Active-high	
5	V <sub>OUT</sub>	Output Pin	

\*1 The tab on the bottom of the package enhances thermal performance and is electrically connected to GND (substrate level). It is recommended that the tab be connected to the ground plane on the board, or otherwise be left open.

**PIN EQUIVALENT CIRCUIT DIAGRAMS**

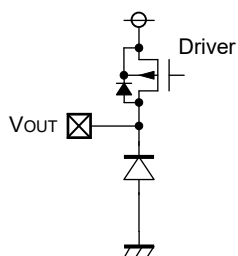

**V<sub>OUT</sub> Pin**

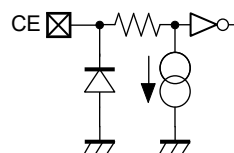

**CE Pin**

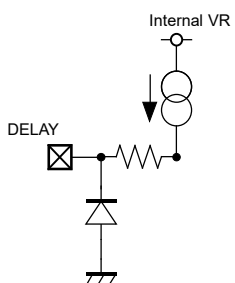

**DELAY Pin (R1517Jxx1E/F)**

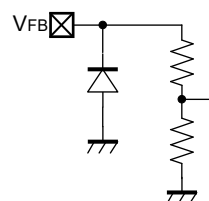

**V<sub>FB</sub> Pin (R1517x001C)**

## ABSOLUTE MAXIMUM RATINGS

Symbol	Item		Rating	Unit
V <sub>IN</sub>	Input Voltage		-0.3 to 50	V
V <sub>IN</sub>	Peak Input Voltage* <sup>1</sup>		60	V
V <sub>CE</sub>	Input Voltage (CE Pin)		-0.3 to 50	V
V <sub>FB</sub>	Input Voltage (V <sub>FB</sub> Pin)		-0.3 to 50	V
V <sub>OUT</sub>	Output Voltage		-0.3 to V <sub>IN</sub> + 0.3 ≤ 50	V
P <sub>D</sub>	Power Dissipation (HSOP-6J)* <sup>2</sup>	Standard Land Pattern	2100	mW
		Ultra High Wattage Land Pattern	3400	
	Power Dissipation (TO-252-5-P2)* <sup>2</sup>	Standard Land Pattern	2350	
		Ultra High Wattage Land Pattern	4800	
T <sub>j</sub>	Junction Temperature		-40 to 150	°C
T <sub>stg</sub>	Storage Temperature Range		-55 to 150	°C

\*<sup>1</sup> Duration time = 200 ms

\*<sup>2</sup> Refer to *PACKAGE INFORMATION* for detailed information.

### ABSOLUTE MAXIMUM RATINGS

Electronic and mechanical stress momentarily exceeded absolute maximum ratings may cause the permanent damage and may degrade the life time and safety for both device and system using the device in the field. The functional operation at or over these absolute maximum ratings is not assured.

## RECOMMENDED OPERATING CONDITIONS

Symbol	Item	Rating	Unit
V <sub>IN</sub>	Input Voltage	3.5 to 36	V
T <sub>a</sub>	Operating Temperature Range	-40 to 125	°C

### RECOMMENDED OPERATING CONDITONS

All of electronic equipment should be designed that the mounted semiconductor devices operate within the recommended operating conditions. The semiconductor devices cannot operate normally over the recommended operating conditions, even if they are used over such conditions by momentary electronic noise or surge. And the semiconductor devices may receive serious damage when they continue to operate over the recommended operating conditions.

## ELECTRICAL CHARACTERISTICS

$V_{IN} = V_{SET} + 1.0 \text{ V}$ ,  $I_{OUT} = 1 \text{ mA}$ ,  $C_{IN} = C_{OUT} = 0.1 \mu\text{F}$ , unless otherwise noted.

The specifications surrounded by   are guaranteed by design engineering at  $-40^\circ\text{C} \leq T_a \leq 125^\circ\text{C}$ .

### R1517xxxxB/D (-AE)

( $T_a = 25^\circ\text{C}$ )

Symbol	Item	Conditions	Min.	Typ.	Max.	Unit	
$V_{OUT}$	Output Voltage	$T_a = 25^\circ\text{C}$	$V_{SET} \leq 5.0 \text{ V}$	$\times 0.992$		$\times 1.008$	V
			$V_{SET} > 5.0 \text{ V}$	$\times 0.99$		$\times 1.01$	V
		$-40^\circ\text{C} \leq T_a \leq 125^\circ\text{C}$	$V_{SET} \leq 5.0 \text{ V}$	<span style="border: 1px solid black; padding: 0 2px;"><math>\times 0.982</math></span>		<span style="border: 1px solid black; padding: 0 2px;"><math>\times 1.018</math></span>	V
			$V_{SET} > 5.0 \text{ V}$	<span style="border: 1px solid black; padding: 0 2px;"><math>\times 0.98</math></span>		<span style="border: 1px solid black; padding: 0 2px;"><math>\times 1.02</math></span>	V
$\frac{\Delta V_{OUT}}{\Delta I_{OUT}}$	Load Regulation	$V_{IN} = V_{SET} + 2.0 \text{ V}$ $1 \text{ mA} \leq I_{OUT} \leq 250 \text{ mA}$	<span style="border: 1px solid black; padding: 0 2px;">-15</span>	3	<span style="border: 1px solid black; padding: 0 2px;">25</span>	mV	
		$V_{IN} = V_{SET} + 2.0 \text{ V}$ $1 \text{ mA} \leq I_{OUT} \leq 500 \text{ mA}$	<span style="border: 1px solid black; padding: 0 2px;">-25</span>	5	<span style="border: 1px solid black; padding: 0 2px;">40</span>	mV	
$V_{DIF}$	Dropout Voltage	$I_{OUT} = 500 \text{ mA}$	Refer to Product-specific Electrical Characteristics.				
$I_{SS}$	Supply Current	$I_{OUT} = 0 \text{ mA}$		18	<span style="border: 1px solid black; padding: 0 2px;">36</span>	$\mu\text{A}$	
Istandby	Standby Current	$V_{CE} = 0 \text{ V}$		0.1	<span style="border: 1px solid black; padding: 0 2px;">2.0</span>	$\mu\text{A}$	
$\frac{\Delta V_{OUT}}{\Delta V_{IN}}$	Line Regulation	$V_{SET} + 0.5 \text{ V} \leq V_{IN} \leq 36 \text{ V}$ , Under the condition of $V_{IN} \geq 3.5 \text{ V}$		0.01	<span style="border: 1px solid black; padding: 0 2px;">0.02</span>	%/V	
$I_{LIM}$	Output Current Limit	$V_{IN} = V_{SET} + 2.0 \text{ V}$	<span style="border: 1px solid black; padding: 0 2px;">500</span>	750		mA	
$I_{SC}$	Short Current Limit	$V_{IN} = 5.0 \text{ V}$ , $V_{OUT} = 0 \text{ V}$		75		mA	
$I_{PD}$	CE Pull-down Current	$V_{CE} = 5.0 \text{ V}$		0.2	<span style="border: 1px solid black; padding: 0 2px;">0.6</span>	$\mu\text{A}$	
		$V_{CE} = 36 \text{ V}$		0.5	<span style="border: 1px solid black; padding: 0 2px;">1.3</span>	$\mu\text{A}$	
$t_{D1}$	Soft-start Time 1			120		$\mu\text{s}$	
$V_{CEH}$	CE Input Voltage "H"		<span style="border: 1px solid black; padding: 0 2px;">2.2</span>		<span style="border: 1px solid black; padding: 0 2px;">36</span>	V	
$V_{CEL}$	CE Input Voltage "L"		<span style="border: 1px solid black; padding: 0 2px;">0</span>		<span style="border: 1px solid black; padding: 0 2px;">1.0</span>	V	
$T_{TSD}$	Thermal Shutdown Temperature	Junction Temperature	<span style="border: 1px solid black; padding: 0 2px;">150</span>	160		$^\circ\text{C}$	
$T_{TSR}$	Thermal Shutdown Released Temperature	Junction Temperature	<span style="border: 1px solid black; padding: 0 2px;">125</span>	135		$^\circ\text{C}$	
$R_{LOW}$	Low Output Nch Tr. ON Resistance (R1517xxxxD)	$V_{IN} = 14.0 \text{ V}$ , $V_{CE} = 0 \text{ V}$	<span style="border: 1px solid black; padding: 0 2px;">1.0</span>	3.2	<span style="border: 1px solid black; padding: 0 2px;">5.0</span>	k $\Omega$	

All test items listed under Electrical Characteristics are done under the pulse load condition ( $T_j \approx T_a = 25^\circ\text{C}$ ) except for Soft-start Time 1.

$V_{IN} = V_{FB} (= 2.5 \text{ V}) + 1.0 \text{ V} = 3.5 \text{ V}$ ,  $I_{OUT} = 1 \text{ mA}$ ,  $C_{IN} = 0.1 \mu\text{F}$ ,  $C_{OUT} = 1.0 \mu\text{F}$ , unless otherwise noted.

The specifications surrounded by   are guaranteed by design engineering at  $-40^\circ\text{C} \leq T_a \leq 125^\circ\text{C}$ .

## R1517x001C (-AE)

(Ta = 25°C)

Symbol	Item	Conditions	Min.	Typ.	Max.	Unit
$V_{FB}$	Feedback Voltage	$T_a = 25^\circ\text{C}$	2.480		2.520	V
		$-40^\circ\text{C} \leq T_a \leq 125^\circ\text{C}$	<span style="border: 1px solid black; padding: 0 2px;">2.455</span>		<span style="border: 1px solid black; padding: 0 2px;">2.545</span>	V
$\frac{\Delta V_{OUT}}{\Delta I_{OUT}}$	Load Regulation	$V_{IN} = 4.5 \text{ V}$ $1 \text{ mA} \leq I_{OUT} \leq 250 \text{ mA}$	<span style="border: 1px solid black; padding: 0 2px;">-10</span>	3	<span style="border: 1px solid black; padding: 0 2px;">10</span>	mV
		$V_{IN} = 4.5 \text{ V}$ $1 \text{ mA} \leq I_{OUT} \leq 500 \text{ mA}$	<span style="border: 1px solid black; padding: 0 2px;">-20</span>	5	<span style="border: 1px solid black; padding: 0 2px;">20</span>	mV
$V_{DIF}$	Dropout Voltage	$I_{OUT} = 500 \text{ mA}$		/	1.0	V
$I_{SS}$	Supply Current	$I_{OUT} = 0 \text{ mA}$		18	<span style="border: 1px solid black; padding: 0 2px;">36</span>	$\mu\text{A}$
Istandby	Standby Current	$V_{CE} = 0 \text{ V}$		0.1	<span style="border: 1px solid black; padding: 0 2px;">2.0</span>	$\mu\text{A}$
$\frac{\Delta V_{OUT}}{\Delta V_{IN}}$	Line Regulation	$3.5 \text{ V} \leq V_{IN} \leq 36 \text{ V}$		0.01	<span style="border: 1px solid black; padding: 0 2px;">0.02</span>	%/V
$I_{LIM}$	Output Current Limit	$V_{IN} = 4.5 \text{ V}$	<span style="border: 1px solid black; padding: 0 2px;">500</span>	750		mA
$I_{SC}$	Short Current Limit	$V_{IN} = 5.0 \text{ V}$ , $V_{OUT} = V_{FB} = 0 \text{ V}$		75		mA
$I_{PD}$	CE Pull-down Current	$V_{CE} = 5.0 \text{ V}$		0.2	<span style="border: 1px solid black; padding: 0 2px;">0.6</span>	$\mu\text{A}$
		$V_{CE} = 36 \text{ V}$		0.5	<span style="border: 1px solid black; padding: 0 2px;">1.3</span>	$\mu\text{A}$
$t_{D1}$	Soft-start Time 1			120		$\mu\text{s}$
$V_{CEH}$	CE Input Voltage "H"		<span style="border: 1px solid black; padding: 0 2px;">2.2</span>		<span style="border: 1px solid black; padding: 0 2px;">36</span>	V
$V_{CEL}$	CE Input Voltage "L"		<span style="border: 1px solid black; padding: 0 2px;">0</span>		<span style="border: 1px solid black; padding: 0 2px;">1.0</span>	V
$T_{TSD}$	Thermal Shutdown Temperature	Junction Temperature	<span style="border: 1px solid black; padding: 0 2px;">150</span>	160		$^\circ\text{C}$
$T_{TSR}$	Thermal Shutdown Released Temperature	Junction Temperature	<span style="border: 1px solid black; padding: 0 2px;">125</span>	135		$^\circ\text{C}$

$V_{OUT} = V_{FB} = 2.5 \text{ V}$  (excluding short circuit current)

All test items listed under Electrical Characteristics are done under the pulse load condition ( $T_j \approx T_a = 25^\circ\text{C}$ ) except for Soft-start Time 1.



$V_{IN} = V_{SET} + 1.0 \text{ V}$ ,  $I_{OUT} = 1 \text{ mA}$ ,  $C_{IN} = C_{OUT} = 0.1 \mu\text{F}$ , unless otherwise noted.

The specifications surrounded by   are guaranteed by design engineering at  $-40^\circ\text{C} \leq T_a \leq 125^\circ\text{C}$ .

## R1517Jxx1E/F (-AE)

(Ta = 25°C)

Symbol	Item	Conditions	Min.	Typ.	Max.	Unit	
$V_{OUT}$	Output Voltage	Ta = 25°C	$V_{SET} \leq 5.0 \text{ V}$	$\times 0.992$		$\times 1.008$	V
			$V_{SET} > 5.0 \text{ V}$	$\times 0.99$		$\times 1.01$	V
		$-40^\circ\text{C} \leq T_a \leq 125^\circ\text{C}$	$V_{SET} \leq 5.0 \text{ V}$	<span style="border: 1px solid black; padding: 0 2px;">×0.982</span>		<span style="border: 1px solid black; padding: 0 2px;">×1.018</span>	V
			$V_{SET} > 5.0 \text{ V}$	<span style="border: 1px solid black; padding: 0 2px;">×0.98</span>		<span style="border: 1px solid black; padding: 0 2px;">×1.02</span>	V
$\Delta V_{OUT} / \Delta I_{OUT}$	Load Regulation	$V_{IN} = V_{SET} + 2.0 \text{ V}$ $1 \text{ mA} \leq I_{OUT} \leq 250 \text{ mA}$	<span style="border: 1px solid black; padding: 0 2px;">-15</span>	3	<span style="border: 1px solid black; padding: 0 2px;">25</span>	mV	
		$V_{IN} = V_{SET} + 2.0 \text{ V}$ $1 \text{ mA} \leq I_{OUT} \leq 500 \text{ mA}$	<span style="border: 1px solid black; padding: 0 2px;">-25</span>	5	<span style="border: 1px solid black; padding: 0 2px;">40</span>	mV	
$V_{DIF}$	Dropout Voltage	$I_{OUT} = 500 \text{ mA}$	Refer to Product-specific Electrical Characteristics.				
$I_{SS}$	Supply Current	$I_{OUT} = 0 \text{ mA}$		18	<span style="border: 1px solid black; padding: 0 2px;">36</span>	$\mu\text{A}$	
Istandby	Standby Current	$V_{CE} = 0 \text{ V}$		0.1	<span style="border: 1px solid black; padding: 0 2px;">2.0</span>	$\mu\text{A}$	
$\Delta V_{OUT} / \Delta V_{IN}$	Line Regulation	$V_{SET} + 0.5 \text{ V} \leq V_{IN} \leq 36 \text{ V}$ , Under the condition of $V_{IN} \geq 3.5 \text{ V}$		0.01	<span style="border: 1px solid black; padding: 0 2px;">0.02</span>	%/V	
$I_{LIM}$	Output Current Limit	$V_{IN} = V_{SET} + 2.0 \text{ V}$	<span style="border: 1px solid black; padding: 0 2px;">500</span>	750		mA	
$I_{SC}$	Short Current Limit	$V_{IN} = 5.0 \text{ V}$ , $V_{OUT} = 0 \text{ V}$		75		mA	
$I_{PD}$	CE Pull-down Current	$V_{CE} = 5.0 \text{ V}$		0.2	<span style="border: 1px solid black; padding: 0 2px;">0.6</span>	$\mu\text{A}$	
		$V_{CE} = 36 \text{ V}$		0.5	<span style="border: 1px solid black; padding: 0 2px;">1.3</span>	$\mu\text{A}$	
$I_{DELAY}$	DELAY Current	DELAY = GND	<span style="border: 1px solid black; padding: 0 2px;">1.5</span>	2.5	<span style="border: 1px solid black; padding: 0 2px;">3.5</span>	$\mu\text{A}$	
$t_{D1}$	Soft-start Time 1	DELAY = OPEN		26		$\mu\text{s}$	
$t_{D2}$	Soft-start Time 2	DELAY = 0.001 $\mu\text{F}$	210	290	415	$\mu\text{s}$	
$V_{CEH}$	CE Input Voltage "H"		<span style="border: 1px solid black; padding: 0 2px;">2.2</span>		<span style="border: 1px solid black; padding: 0 2px;">36</span>	V	
$V_{CEL}$	CE Input Voltage "L"		<span style="border: 1px solid black; padding: 0 2px;">0</span>		<span style="border: 1px solid black; padding: 0 2px;">1.0</span>	V	
$T_{TSD}$	Thermal Shutdown Temperature	Junction Temperature	<span style="border: 1px solid black; padding: 0 2px;">150</span>	160		$^\circ\text{C}$	
$T_{TSR}$	Thermal Shutdown Released Temperature	Junction Temperature	<span style="border: 1px solid black; padding: 0 2px;">125</span>	135		$^\circ\text{C}$	
$R_{LOW}$	Low Output Nch Tr. ON Resistance (R1517Jxx1F)	$V_{IN} = 14.0 \text{ V}$ , $V_{CE} = 0 \text{ V}$	<span style="border: 1px solid black; padding: 0 2px;">1.0</span>	3.2	<span style="border: 1px solid black; padding: 0 2px;">5.0</span>	k $\Omega$	

All test items listed under Electrical Characteristics are done under the pulse load condition ( $T_j \approx T_a = 25^\circ\text{C}$ ) except for Soft-start Time 1 and Soft-start Time 2.

### Product-specific Electrical Characteristics

The specifications surrounded by   are guaranteed by design engineering at  $-40^{\circ}\text{C} \leq T_a \leq 125^{\circ}\text{C}$ .

#### R1517Jxx1B/D/E/F (-AE), R1517Sxx2B/D (-AE)

( $T_a = 25^{\circ}\text{C}$ )

Product Name	$V_{\text{OUT}}$ [V] ( $T_a = 25^{\circ}\text{C}$ )			$V_{\text{OUT}}$ [V] ( $-40 \leq T_a \leq 125^{\circ}\text{C}$ )			$V_{\text{DIF}}$ [V]	
	Min.	Typ.	Max.	Min.	Typ.	Max.	Typ.	Max.
R1517x25xx	2.480	2.500	2.520	<span style="border: 1px solid black; padding: 0 2px;">2.455</span>	2.500	<span style="border: 1px solid black; padding: 0 2px;">2.545</span>	/	<span style="border: 1px solid black; padding: 0 2px;">1.00</span>
R1517x28xx	2.778	2.800	2.822	<span style="border: 1px solid black; padding: 0 2px;">2.750</span>	2.800	<span style="border: 1px solid black; padding: 0 2px;">2.850</span>		
R1517x30xx	2.977	3.000	3.024	<span style="border: 1px solid black; padding: 0 2px;">2.946</span>	3.000	<span style="border: 1px solid black; padding: 0 2px;">3.054</span>		
R1517x33xx	3.274	3.300	3.326	<span style="border: 1px solid black; padding: 0 2px;">3.241</span>	3.300	<span style="border: 1px solid black; padding: 0 2px;">3.359</span>	0.45	<span style="border: 1px solid black; padding: 0 2px;">0.77</span>
R1517x34xx	3.373	3.400	3.427	<span style="border: 1px solid black; padding: 0 2px;">3.339</span>	3.400	<span style="border: 1px solid black; padding: 0 2px;">3.461</span>		
R1517x50xx	4.960	5.000	5.040	<span style="border: 1px solid black; padding: 0 2px;">4.910</span>	5.000	<span style="border: 1px solid black; padding: 0 2px;">5.090</span>	0.35	<span style="border: 1px solid black; padding: 0 2px;">0.62</span>
R1517x60xx	5.940	6.000	6.060	<span style="border: 1px solid black; padding: 0 2px;">5.760</span>	6.000	<span style="border: 1px solid black; padding: 0 2px;">6.120</span>		
R1517x80xx	7.920	8.000	8.080	<span style="border: 1px solid black; padding: 0 2px;">7.840</span>	8.000	<span style="border: 1px solid black; padding: 0 2px;">8.160</span>	0.30	<span style="border: 1px solid black; padding: 0 2px;">0.50</span>
R1517x85xx	8.415	8.500	8.585	<span style="border: 1px solid black; padding: 0 2px;">8.330</span>	8.500	<span style="border: 1px solid black; padding: 0 2px;">8.670</span>		
R1517x90xx	8.910	9.000	9.090	<span style="border: 1px solid black; padding: 0 2px;">8.820</span>	9.000	<span style="border: 1px solid black; padding: 0 2px;">9.180</span>		

$V_{IN} = V_{SET} + 1.0 \text{ V}$ ,  $I_{OUT} = 1 \text{ mA}$ ,  $C_{IN} = C_{OUT} = 0.1 \mu\text{F}$ , unless otherwise noted.

## R1517xxxxB/D (-KE)

( $-40 \leq T_a \leq 125^\circ\text{C}$ )

Symbol	Item	Conditions	Min.	Typ.	Max.	Unit	
$V_{OUT}$	Output Voltage	$T_a = 25^\circ\text{C}$	$V_{SET} \leq 5.0 \text{ V}$	$\times 0.992$		$\times 1.008$	V
			$V_{SET} > 5.0 \text{ V}$	$\times 0.99$		$\times 1.01$	V
		$-40^\circ\text{C} \leq T_a \leq 125^\circ\text{C}$	$V_{SET} \leq 5.0 \text{ V}$	$\times 0.982$		$\times 1.018$	V
			$V_{SET} > 5.0 \text{ V}$	$\times 0.98$		$\times 1.02$	V
$\frac{\Delta V_{OUT}}{\Delta I_{OUT}}$	Load Regulation	$V_{IN} = V_{SET} + 2.0 \text{ V}$ $1 \text{ mA} \leq I_{OUT} \leq 250 \text{ mA}$	-15	3	25	mV	
		$V_{IN} = V_{SET} + 2.0 \text{ V}$ $1 \text{ mA} \leq I_{OUT} \leq 500 \text{ mA}$	-25	5	40	mV	
$V_{DIF}$	Dropout Voltage	$I_{OUT} = 500 \text{ mA}$	Refer to Product-specific Electrical Characteristics.				
$I_{SS}$	Supply Current	$I_{OUT} = 0 \text{ mA}$		18	36	$\mu\text{A}$	
Istandby	Standby Current	$V_{CE} = 0 \text{ V}$		0.1	2.0	$\mu\text{A}$	
$\frac{\Delta V_{OUT}}{\Delta V_{IN}}$	Line Regulation	$V_{SET} + 0.5 \text{ V} \leq V_{IN} \leq 36 \text{ V}$ , Under the condition of $V_{IN} \geq 3.5 \text{ V}$		0.01	0.02	%/V	
$I_{LIM}$	Output Current Limit	$V_{IN} = V_{SET} + 2.0 \text{ V}$	500	750	1000	mA	
$I_{SC}$	Short Current Limit	$V_{IN} = 5.0 \text{ V}$ , $V_{OUT} = 0 \text{ V}$	50	75	100	mA	
$I_{PD}$	CE Pull-down Current	$V_{CE} = 5.0 \text{ V}$		0.2	0.6	$\mu\text{A}$	
		$V_{CE} = 36 \text{ V}$		0.5	1.3	$\mu\text{A}$	
$V_{CEH}$	CE Input Voltage "H"		2.2		36	V	
$V_{CEL}$	CE Input Voltage "L"		0		1.0	V	
$T_{TSD}$	Thermal Shutdown Temperature	Junction Temperature	150	160		$^\circ\text{C}$	
$T_{TSR}$	Thermal Shutdown Released Temperature	Junction Temperature	125	135		$^\circ\text{C}$	
$R_{LOW}$	Low Output Nch Tr. ON Resistance (R1517xxxxD)	$V_{IN} = 14.0 \text{ V}$ , $V_{CE} = 0 \text{ V}$	1.0	3.2	5.0	k $\Omega$	

$V_{IN} = V_{FB} (= 2.5 \text{ V}) + 1.0 \text{ V} = 3.5 \text{ V}$ ,  $I_{OUT} = 1 \text{ mA}$ ,  $C_{IN} = 0.1 \mu\text{F}$ ,  $C_{OUT} = 1.0 \mu\text{F}$ , unless otherwise noted.

## R1517x001C (-KE)

(-40 ≤ Ta ≤ 125°C)

Symbol	Item	Conditions	Min.	Typ.	Max.	Unit
V <sub>FB</sub>	Feedback Voltage	Ta = 25°C	2.480		2.520	V
		-40°C ≤ Ta ≤ 125°C	2.455		2.545	V
ΔV <sub>OUT</sub> /ΔI <sub>OUT</sub>	Load Regulation	V <sub>IN</sub> = 4.5 V 1 mA ≤ I <sub>OUT</sub> ≤ 250 mA	-10	3	10	mV
		V <sub>IN</sub> = 4.5 V 1 mA ≤ I <sub>OUT</sub> ≤ 500 mA	-20	5	20	mV
V <sub>DIF</sub>	Dropout Voltage	I <sub>OUT</sub> = 500 mA			1.0	V
I <sub>SS</sub>	Supply Current	I <sub>OUT</sub> = 0 mA		18	36	μA
I <sub>standby</sub>	Standby Current	V <sub>CE</sub> = 0 V		0.1	2.0	μA
ΔV <sub>OUT</sub> /ΔV <sub>IN</sub>	Line Regulation	3.5 V ≤ V <sub>IN</sub> ≤ 36 V		0.01	0.02	%/V
I <sub>LIM</sub>	Output Current Limit	V <sub>IN</sub> = 4.5 V	500	750	1000	mA
I <sub>SC</sub>	Short Current Limit	V <sub>IN</sub> = 5.0 V, V <sub>OUT</sub> = V <sub>FB</sub> = 0 V	50	75	100	mA
I <sub>PD</sub>	CE Pull-down Current	V <sub>CE</sub> = 5.0 V		0.2	0.6	μA
		V <sub>CE</sub> = 36 V		0.5	1.3	μA
V <sub>CEH</sub>	CE Input Voltage "H"		2.2		36	V
V <sub>CEL</sub>	CE Input Voltage "L"		0		1.0	V
T <sub>TSD</sub>	Thermal Shutdown Temperature	Junction Temperature	150	160		°C
T <sub>TSR</sub>	Thermal Shutdown Released Temperature	Junction Temperature	125	135		°C

V<sub>OUT</sub> = V<sub>FB</sub> = 2.5 V (excluding short circuit current)

$V_{IN} = V_{SET} + 1.0 \text{ V}$ ,  $I_{OUT} = 1 \text{ mA}$ ,  $C_{IN} = C_{OUT} = 0.1 \mu\text{F}$ , unless otherwise noted.

## R1517Jxx1E/F(-KE)

( $-40 \leq T_a \leq 125^\circ\text{C}$ )

Symbol	Item	Conditions	Min.	Typ.	Max.	Unit	
$V_{OUT}$	Output Voltage	$T_a = 25^\circ\text{C}$	$V_{SET} \leq 5.0 \text{ V}$	$\times 0.992$		$\times 1.008$	V
			$V_{SET} > 5.0 \text{ V}$	$\times 0.99$		$\times 1.01$	V
		$-40^\circ\text{C} \leq T_a \leq 125^\circ\text{C}$	$V_{SET} \leq 5.0 \text{ V}$	$\times 0.982$		$\times 1.018$	V
			$V_{SET} > 5.0 \text{ V}$	$\times 0.98$		$\times 1.02$	V
$\frac{\Delta V_{OUT}}{\Delta I_{OUT}}$	Load Regulation	$V_{IN} = V_{SET} + 2.0 \text{ V}$ $1 \text{ mA} \leq I_{OUT} \leq 250 \text{ mA}$	-15	3	25	mV	
		$V_{IN} = V_{SET} + 2.0 \text{ V}$ $1 \text{ mA} \leq I_{OUT} \leq 500 \text{ mA}$	-25	5	40	mV	
$V_{DIF}$	Dropout Voltage	$I_{OUT} = 500 \text{ mA}$	Refer to Product-specific Electrical Characteristics.				
$I_{SS}$	Supply Current	$I_{OUT} = 0 \text{ mA}$		18	36	$\mu\text{A}$	
Istandby	Standby Current	$V_{CE} = 0 \text{ V}$		0.1	2.0	$\mu\text{A}$	
$\frac{\Delta V_{OUT}}{\Delta V_{IN}}$	Line Regulation	$V_{SET} + 0.5 \text{ V} \leq V_{IN} \leq 36 \text{ V}$ , Under the condition of $V_{IN} \geq 3.5 \text{ V}$		0.01	0.02	%/V	
$V_{IN}$	Input Voltage		3.5		36	V	
$I_{LIM}$	Output Current Limit	$V_{IN} = V_{SET} + 2.0 \text{ V}$	500	750	1000	mA	
$I_{SC}$	Short Current Limit	$V_{IN} = 5.0 \text{ V}$ , $V_{OUT} = 0 \text{ V}$	50	75	100	mA	
$I_{PD}$	CE Pull-down Current	$V_{CE} = 5.0 \text{ V}$		0.2	0.6	$\mu\text{A}$	
		$V_{CE} = 36 \text{ V}$		0.5	1.3	$\mu\text{A}$	
$I_{DELAY}$	DELAY Current	DELAY = GND	1.5	2.5	3.5	$\mu\text{A}$	
$V_{CEH}$	CE Input Voltage "H"		2.2		36	V	
$V_{CEL}$	CE Input Voltage "L"		0		1.0	V	
$T_{TSD}$	Thermal Shutdown Temperature	Junction Temperature	150	160		$^\circ\text{C}$	
$T_{TSR}$	Thermal Shutdown Released Temperature	Junction Temperature	125	135		$^\circ\text{C}$	
$R_{LOW}$	Low Output Nch Tr. ON Resistance (R1517Jxx1F)	$V_{IN} = 14.0 \text{ V}$ , $V_{CE} = 0 \text{ V}$	1.0	3.2	5.0	k $\Omega$	

## Product-specific Electrical Characteristics

R1517Jxx1B/D/E/F (-KE), R1517Sxx2B/D (-KE)

(-40 ≤ Ta ≤ 125°C)

Product Name	V <sub>OUT</sub> [V] (Ta = 25°C)			V <sub>OUT</sub> [V] (-40 ≤ Ta ≤ 125°C)			V <sub>DIF</sub> [V]	
	Min.	Typ.	Max.	Min.	Typ.	Max.	Typ.	Max.
R1517x25xx	2.480	2.500	2.520	2.455	2.500	2.545	/	1.00
R1517x28xx	2.778	2.800	2.822	2.750	2.800	2.850		
R1517x30xx	2.977	3.000	3.024	2.946	3.000	3.054		
R1517x33xx	3.274	3.300	3.326	3.241	3.300	3.359	0.45	0.77
R1517x34xx	3.373	3.400	3.427	3.339	3.400	3.461		
R1517x50xx	4.960	5.000	5.040	4.910	5.000	5.090	0.35	0.62
R1517x60xx	5.940	6.000	6.060	5.760	6.000	6.120		
R1517x80xx	7.920	8.000	8.080	7.840	8.000	8.160		
R1517x85xx	8.415	8.500	8.585	8.330	8.500	8.670	0.30	0.50
R1517x90xx	8.910	9.000	9.090	8.820	9.000	9.180		

## TYPICAL APPLICATION

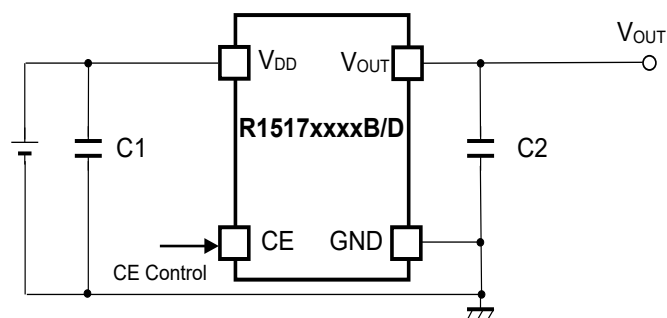

R1517xxxxB/D Typical Application

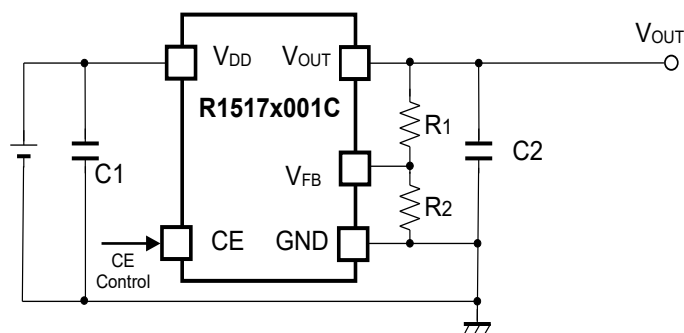

R1517x001C Typical Application

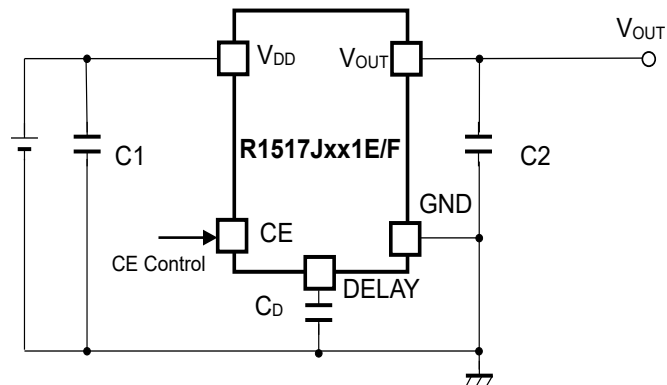

R1517Jxx1E/F Typical Application

## External Components:

Symbol	Description
<b>R1517xxxxB/D/E/F</b>	
C1 (C <sub>IN</sub> )	0.1μF (Ceramic)
C2 (C <sub>OUT</sub> )	0.1μF (Ceramic)
<b>R1517x001C</b>	
C1 (C <sub>IN</sub> )	0.1μF (Ceramic)
C2 (C <sub>OUT</sub> )	1.0μF (Ceramic)

## TECHNICAL NOTES

### Phase Compensation

In LDO regulators, phase compensation is provided to secure stable operation even when the load current is varied. For this purpose, use the capacitor C2 of 0.1  $\mu\text{F}$  or more (R1517xxxxB/D/E/F) / 1.0  $\mu\text{F}$  or more (R1517x001C).

When using a tantalum type capacitor and the ESR (Equivalent Series Resistance) value is large, the output might be unstable. Evaluate the circuit including consideration of frequency characteristics.

For the externally adjustable output voltage type (R1517x001C), use 10 k $\Omega$  or lower resistance R2.

### PCB Layout

Ensure the  $V_{\text{DD}}$  and GND lines are sufficiently robust. If their impedance is too high, noise pickup or unstable operation may result. Connect 0.1  $\mu\text{F}$  or more of the capacitor C1 between the  $V_{\text{DD}}$  and GND, and as close as possible to the pins.

In addition, connect the capacitor C2 between  $V_{\text{OUT}}$  and GND, and as close as possible to the pins.

## TYPICAL APPLICATION FOR IC CHIP BREAKDOWN PREVENTION

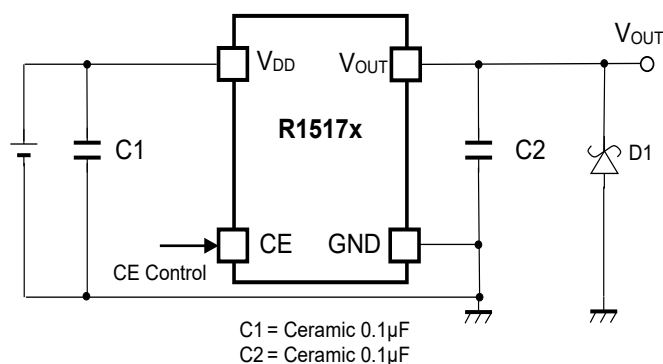

When a sudden surge of electrical current travels along the  $V_{\text{OUT}}$  pin and GND due to a short-circuit, electrical resonance of a circuit involving an output capacitor (C2) and a short circuit inductor generates a negative voltage and may damage the device or the load devices. Connecting a schottky diode (D1) between the  $V_{\text{OUT}}$  pin and GND has the effect of preventing damage to them.



## OPERATION DESCRIPTION

### Thermal Shutdown Function

Thermal shutdown function is included in this device. If the junction temperature is more than or equal to 160°C (Typ.), the operation of the regulator would stop. After that, when the junction temperature is less than or equal to 135°C (Typ.), the operation of the regulator would restart. Unless the cause of rising temperature is removed, the regulator repeats on and off, and output waveform would be like consecutive pulses.

### Adjustable Output Voltage Setting (R1517x001C)

The output voltage of R1517x001C can be adjusted by using the external divider resistors (R1, R2). By using the following equation, the output voltage ( $V_{OUT}$ ) can be determined. The voltage which is fixed inside the IC is described as  $V_{FB}$ .

$$V_{OUT} = V_{FB} \times ((R1 + R2) / R2)$$

$$\text{Recommended Range: } 2.5 \text{ V} \leq V_{OUT} \leq 20.0 \text{ V}$$

$$V_{FB} = 2.5 \text{ V}$$

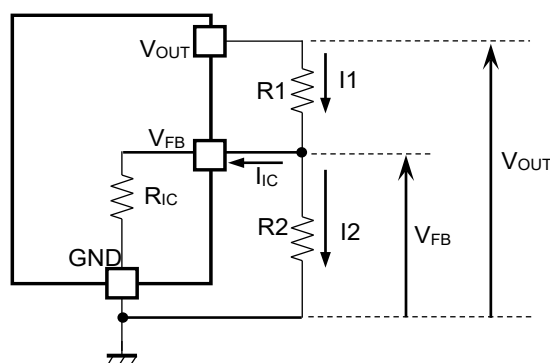

**Output Voltage Adjustment Using External Divider Resistors (R1, R2)**

$R_{IC}$  of the R1517x001C is approximately Typ. 1.35 M $\Omega$  ( $T_a=25^\circ\text{C}$ , guaranteed by design engineering). For better accuracy, setting  $R1 \ll R_{IC}$  reduces errors. The resistance value for R2 should be set to 10 k $\Omega$  or lower. It is easily affected by noises when setting the value of R1 and R2 larger, which makes the impedance of  $V_{FB}$  pin larger.

$R_{IC}$  could be affected by the temperature, therefore evaluate the circuit taking the actual conditions of use into account when deciding the resistance values for R1 and R2.

### Soft-start Function

R1517x is equipped with a constant slope circuit, which achieves a soft-start function. This circuit allows the output voltage to start up gradually when the CE is turned on. The constant slope circuit minimizes the inrush current at the start-up and also prevents the overshoot of the output voltage. For R1517xxxxB/C/D, the capacitor to create the start-up slope is built in this device that does not require any external components. The start-up time and the start-up slope angle are fixed inside the device. In R1517Jxx1E/F, the soft-start time is adjustable by inserting the external capacitor to DELAY pin. By using the following equation, the relation between the soft-start time  $t_D$  [s] and DELAY pin capacitor  $C_D$  [F] is determined.

$$t_D = ((C_D + 90 \times 10^{-12}) / I_{\text{DELAY}}) \times 0.73$$

When the capacitor  $C_D$  is not used in R1517Jxx1E/F, use the DELAY pin as OPEN. At that time,  $C_D = 0$  in the above equation, therefore the start-up time is about 26  $\mu\text{s}$ . However, be sure to consider approximately 50  $\mu\text{s}$  of CE delay time.

#### Conventional Inrush Current Limit Circuit

(Diagrammatic sketch)

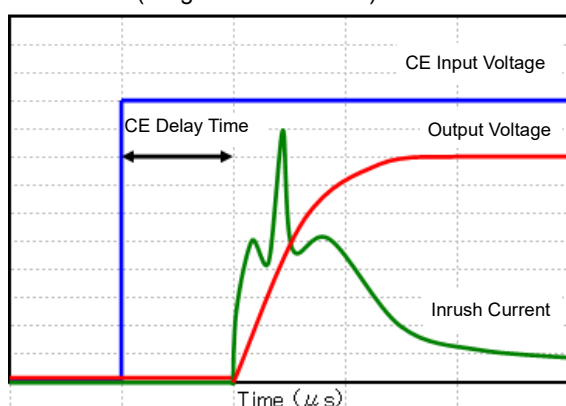

#### Constant Slope Circuit

(Diagrammatic sketch)

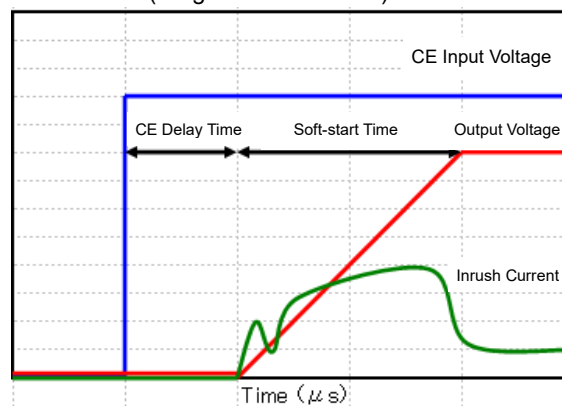

## PACKAGE INFORMATION

### POWER DISSIPATION (HSOP-6J)

The power dissipation of the package is dependent on PCB material, layout, and environmental conditions. The following conditions are used in this measurement.

#### Measurement Conditions

	Ultra-high Wattage Land Pattern	Standard Land Pattern
Environment	Mounting on Board (Wind Velocity = 0 m/s)	Mounting on Board (Wind Velocity = 0 m/s)
Board Material	Glass Cloth Epoxy Plastic (Four-layer Board)	Glass Cloth Epoxy Plastic (Double-sided Board)
Board Dimensions	76.2 mm × 114.3 mm × 0.8 mm	50 mm × 50 mm × 1.6 mm
Copper Ratio	96%	50%
Through-holes	φ 0.3 mm × 28 pcs	φ 0.5 mm × 24 pcs

#### Measurement Result

(Ta = 25°C, Tjmax = 150°C)

	Ultra-high Wattage Land Pattern	Standard Land Pattern	Free Air
Power Dissipation	3400 mW	2100 mW	675 mW
Thermal Resistance	37°C/W	59°C/W	185°C/W

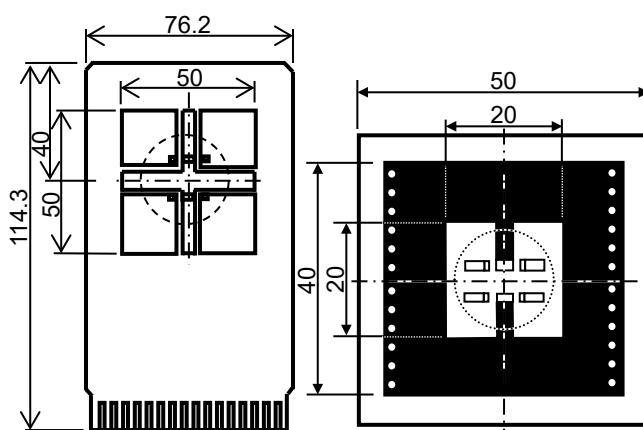
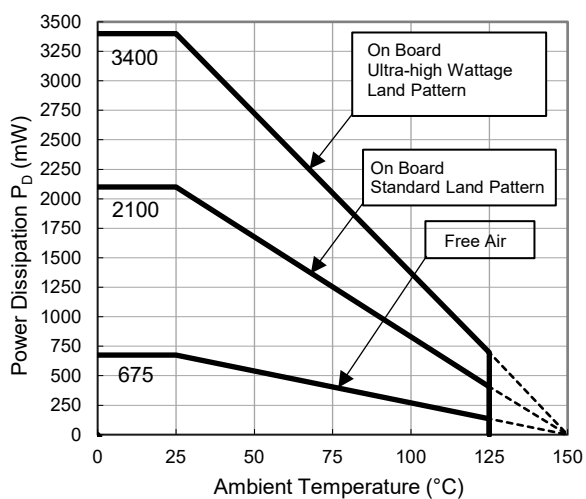

Ultra-high Wattage

Standard

○ IC Mount Area (mm)

Power Dissipation vs. Ambient Temperature

Measurement Board Pattern

PACKAGE DIMENSIONS (HSOP-6J)

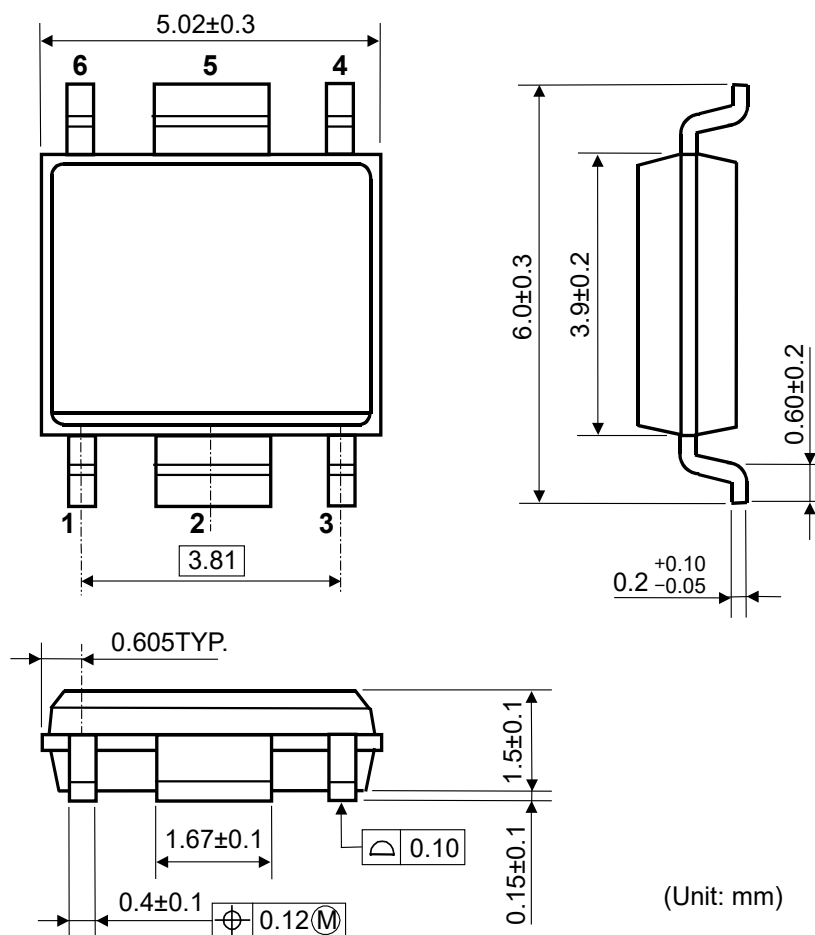

(Unit: mm)

HSOP-6J Package Dimensions

MARK SPECIFICATION (HSOP-6J)

①②③④: Product Code ... Refer to R1517S MARK SPECIFICATION TABLE

⑤⑥: Lot Number ... Alphanumeric Serial Number

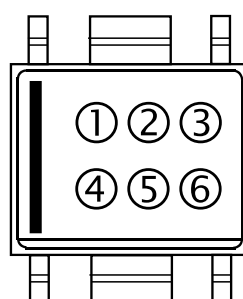

HSOP-6J Mark Specification

**R1517S MARK SPECIFICATION TABLE (HSOP-6J)****R1517Sxx2B**

Product Name	①②③④	V <sub>SET</sub>
R1517S252B	<b>V 6 2 5</b>	2.5 V
R1517S282B	<b>V 6 2 8</b>	2.8 V
R1517S302B	<b>V 6 3 0</b>	3.0 V
R1517S332B	<b>V 6 3 3</b>	3.3 V
R1517S342B	<b>V 6 3 4</b>	3.4 V
R1517S502B	<b>V 6 5 0</b>	5.0 V
R1517S602B	<b>V 6 6 0</b>	6.0 V
R1517S802B	<b>V 6 8 0</b>	8.0 V
R1517S852B	<b>V 6 8 5</b>	8.5 V
R1517S902B	<b>V 6 9 0</b>	9.0 V

**R1517S001C (Adjustable Output Voltage Setting Type)**

Product Name	①②③④	V <sub>SET</sub>
R1517S001C	<b>V 2 0 1</b>	—

**R1517Sxx2D**

Product Name	①②③④	V <sub>SET</sub>
R1517S252D	<b>V 7 2 5</b>	2.5 V
R1517S282D	<b>V 7 2 8</b>	2.8 V
R1517S302D	<b>V 7 3 0</b>	3.0 V
R1517S332D	<b>V 7 3 3</b>	3.3 V
R1517S342D	<b>V 7 3 4</b>	3.4 V
R1517S502D	<b>V 7 5 0</b>	5.0 V
R1517S602D	<b>V 7 6 0</b>	6.0 V
R1517S802D	<b>V 7 8 0</b>	8.0 V
R1517S852D	<b>V 7 8 5</b>	8.5 V
R1517S902D	<b>V 7 9 0</b>	9.0 V

**POWER DISSIPATION (TO-252-5-P2)**

Power Dissipation ( $P_D$ ) depends on conditions of mounting on board. This specification is based on the measurement at the condition below:

Measurement Conditions

	Ultra High Wattage Land Pattern	Standard Land Pattern
Environment	Mounting on board (Wind velocity 0 m/s)	
Board Material	Glass cloth epoxy plastic (Four-layers)	Glass cloth epoxy plastic (Double layers)
Board Dimensions	76.2 mm x 114.3 mm x 0.8 mm	50 mm x 50 mm x 1.6 mm
Copper Ratio	Top, Back side: Approx. 96%, 2nd, 3rd: 100%	Top side: Approx. 50%, Back side: Approx. 50%
Through - hole	$\phi$ 0.4 mm x 30 pcs	$\phi$ 0.5 mm x 24 pcs

Measurement Result

( $T_a = 25^\circ\text{C}$ ,  $T_{j\text{max}} = 150^\circ\text{C}$ )

	Ultra High Wattage Land Pattern	Standard Land Pattern
Power Dissipation	4800 mW	2350 mW
Thermal Resistance	$\theta_{ja} = (150-25^\circ\text{C})/4.8 \text{ W} = 26^\circ\text{C/W}$	$\theta_{ja} = (150-25^\circ\text{C})/2.35 \text{ W} = 53^\circ\text{C/W}$
	$\theta_{jc} = 7^\circ\text{C/W}$	$\theta_{jc} = 17^\circ\text{C/W}$

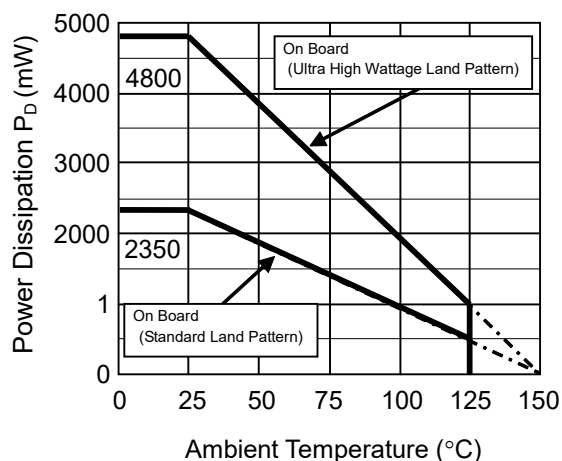

**Power Dissipation**

**Power Dissipation vs. Ambience Temperature**

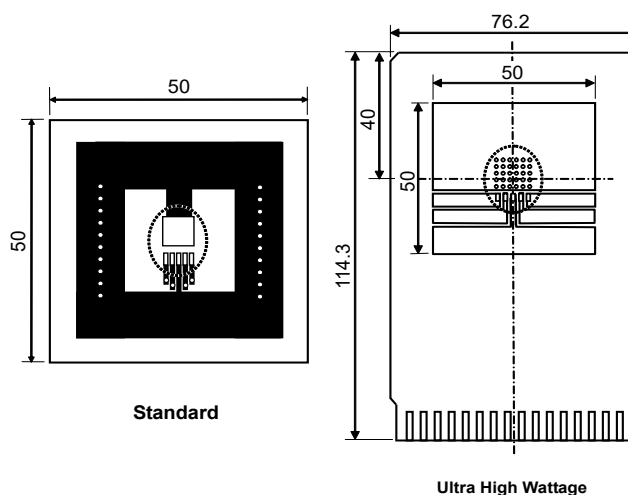

○ IC Mount Area (Unit: mm)

**Measurement Board Pattern**

PACKAGE DIMENSIONS (TO-252-5-P2)

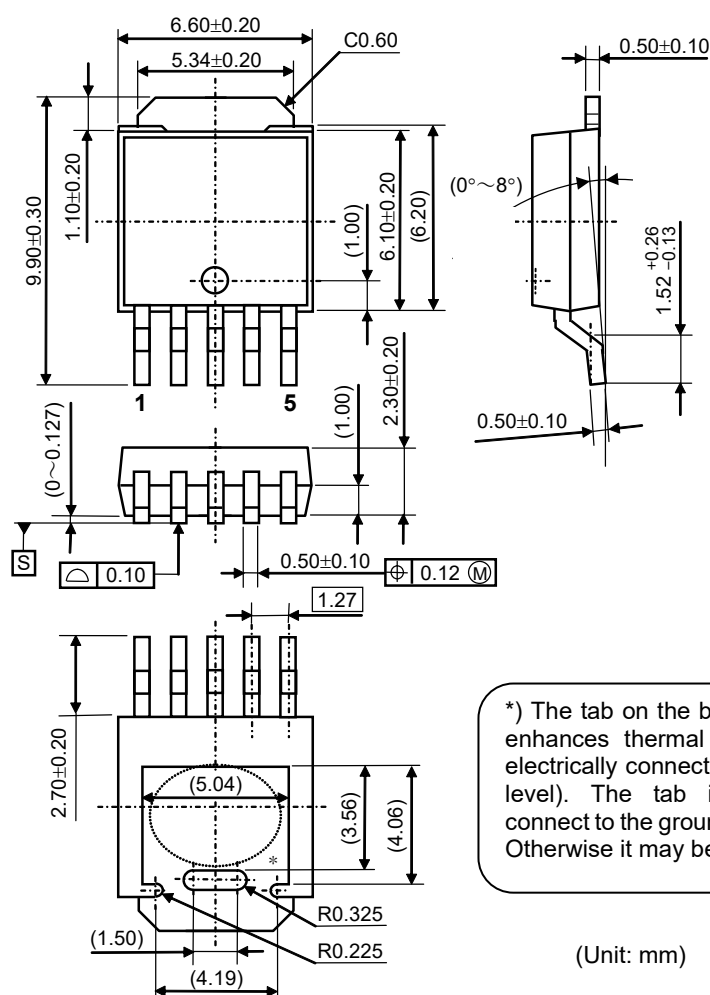

\*) The tab on the bottom of the package enhances thermal performance and is electrically connected to GND (substrate level). The tab is recommended to connect to the ground plane on the board. Otherwise it may be left floating.

TO-252-5-P2 Package Dimensions

MARK SPECIFICATION (TO-252-5-P2)

①②③④⑤⑥⑦⑧: Product Code ... **Refer to R1517J MARK SPECIFICATION TABLE**

⑨⑩: Lot Number ... Alphanumeric Serial Number

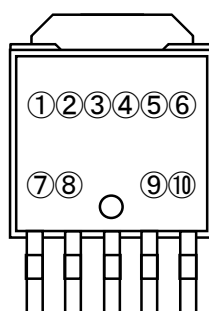

TO-252-5-P2 Mark Specification

## R1517J MARK SPECIFICATION TABLE (TO-252-5-P2)

## R1517Jxx1B

Product Name	①②③④⑤⑥⑦⑧	V <sub>SET</sub>
R1517J251B	K 1 J 2 5 1 B	2.5 V
R1517J281B	K 1 J 2 8 1 B	2.8 V
R1517J301B	K 1 J 3 0 1 B	3.0 V
R1517J331B	K 1 J 3 3 1 B	3.3 V
R1517J341B	K 1 J 3 4 1 B	3.4 V
R1517J501B	K 1 J 5 0 1 B	5.0 V
R1517J601B	K 1 J 6 0 1 B	6.0 V
R1517J801B	K 1 J 8 0 1 B	8.0 V
R1517J851B	K 1 J 8 5 1 B	8.5 V
R1517J901B	K 1 J 9 0 1 B	9.0 V

## R1517J001C (Adjustable Output Voltage Setting Type)

Product Name	①②③④⑤⑥⑦⑧	V <sub>SET</sub>
R1517J001C	K 2 J 0 0 1 C	—

## R1517Jxx1D

Product Name	①②③④⑤⑥⑦⑧	V <sub>SET</sub>
R1517J251D	K 3 J 2 5 1 D	2.5 V
R1517J281D	K 3 J 2 8 1 D	2.8 V
R1517J301D	K 3 J 3 0 1 D	3.0 V
R1517J331D	K 3 J 3 3 1 D	3.3 V
R1517J341D	K 3 J 3 4 1 D	3.4 V
R1517J501D	K 3 J 5 0 1 D	5.0 V
R1517J601D	K 3 J 6 0 1 D	6.0 V
R1517J801D	K 3 J 8 0 1 D	8.0 V
R1517J851D	K 3 J 8 5 1 D	8.5 V
R1517J901D	K 3 J 9 0 1 D	9.0 V

## R1517Jxx1E

Product Name	①②③④⑤⑥⑦⑧	V <sub>SET</sub>
R1517J251E	K 4 J 2 5 1 E	2.5 V
R1517J281E	K 4 J 2 8 1 E	2.8 V
R1517J301E	K 4 J 3 0 1 E	3.0 V
R1517J331E	K 4 J 3 3 1 E	3.3 V
R1517J341E	K 4 J 3 4 1 E	3.4 V
R1517J501E	K 4 J 5 0 1 E	5.0 V
R1517J601E	K 4 J 6 0 1 E	6.0 V
R1517J801E	K 4 J 8 0 1 E	8.0 V
R1517J851E	K 4 J 8 5 1 E	8.5 V
R1517J901E	K 4 J 9 0 1 E	9.0 V

## R1517Jxx1F

Product Name	①②③④⑤⑥⑦⑧	V <sub>SET</sub>
R1517J251F	K 5 J 2 5 1 F	2.5 V
R1517J281F	K 5 J 2 8 1 F	2.8 V
R1517J301F	K 5 J 3 0 1 F	3.0 V
R1517J331F	K 5 J 3 3 1 F	3.3 V
R1517J341F	K 5 J 3 4 1 F	3.4 V
R1517J501F	K 5 J 5 0 1 F	5.0 V
R1517J601F	K 5 J 6 0 1 F	6.0 V
R1517J801F	K 5 J 8 0 1 F	8.0 V
R1517J851F	K 5 J 8 5 1 F	8.5 V
R1517J901F	K 5 J 9 0 1 F	9.0 V



## TYPICAL CHARACTERISTICS

Note: Typical Characteristics are intended to be used as reference data; they are not guaranteed.

### 1) Output Voltage vs. Output Current (Ta = 25°C)

R1517x25xx, R1517x001C

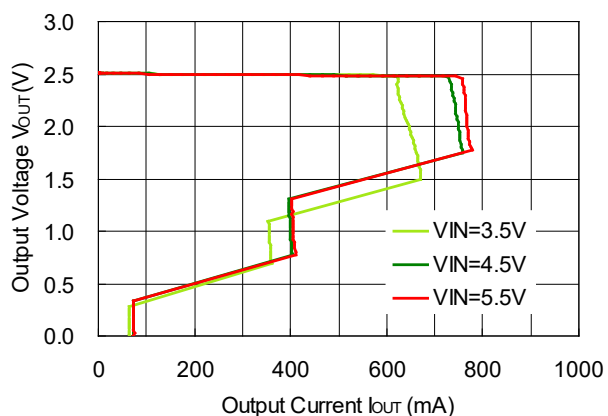

R1517x33xx

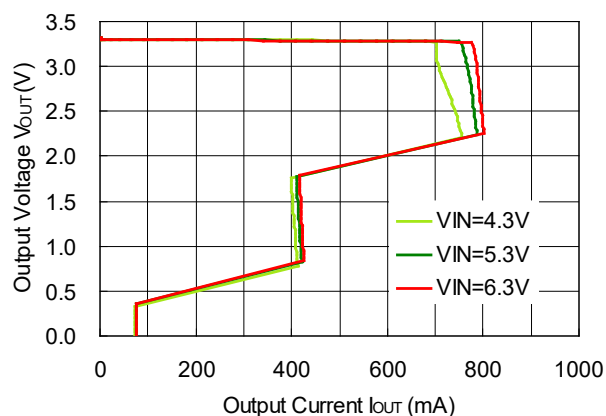

R1517x50xx

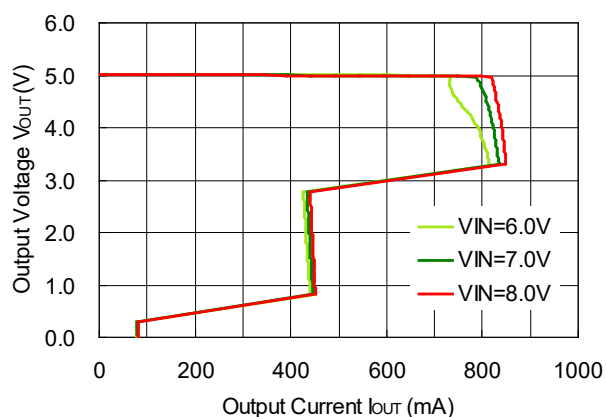

R1517x85xx

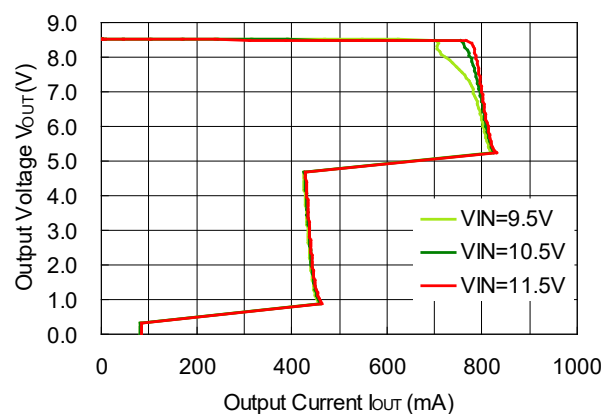

### 2) Output Voltage vs. Input Voltage (Ta = 25°C)

R1517x25xx

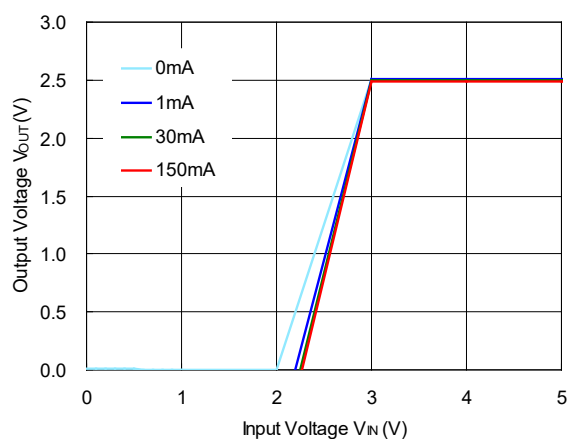

R1517x33xx

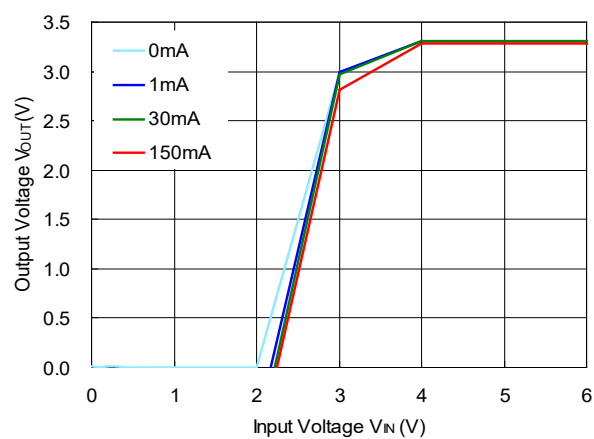

R1517x50xx

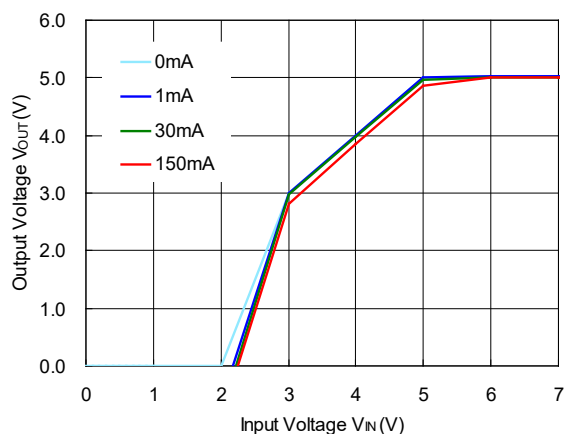

R1517x85xx

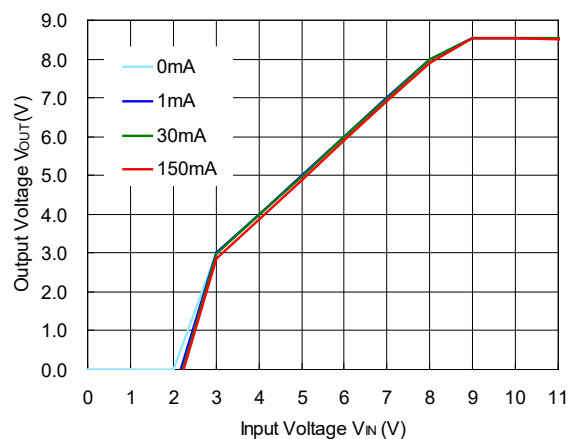

3) Supply Current vs. Input Voltage

R1517x25xx, R1517x001C

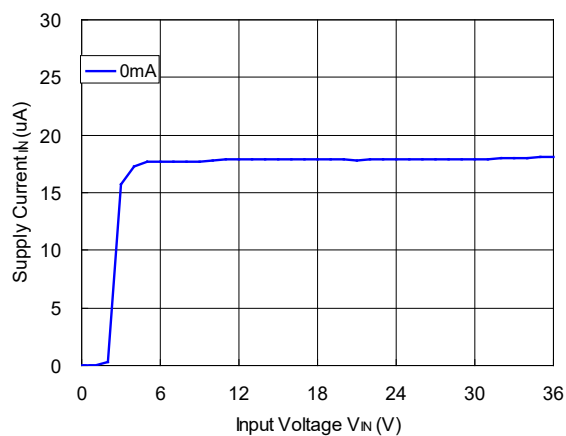

R1517x33xx

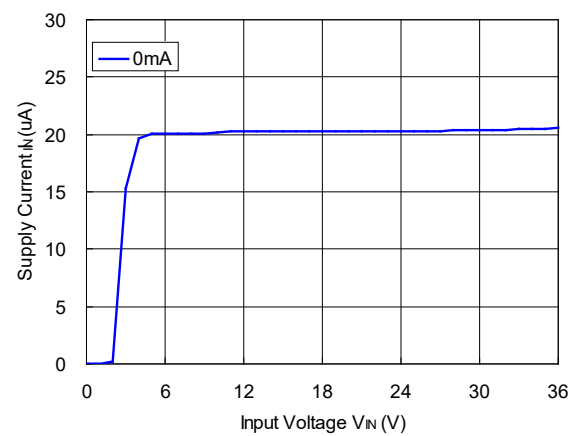

R1517x50xx

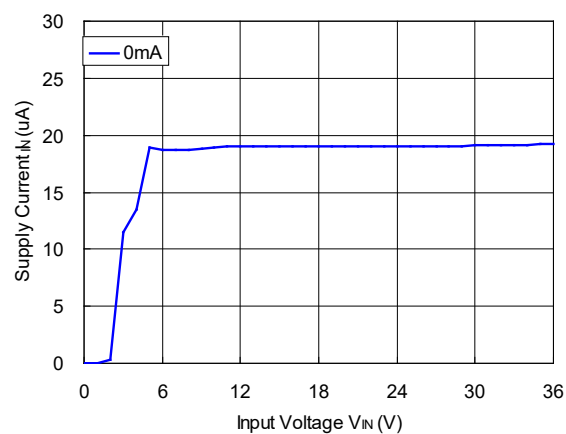

R1517x85xx

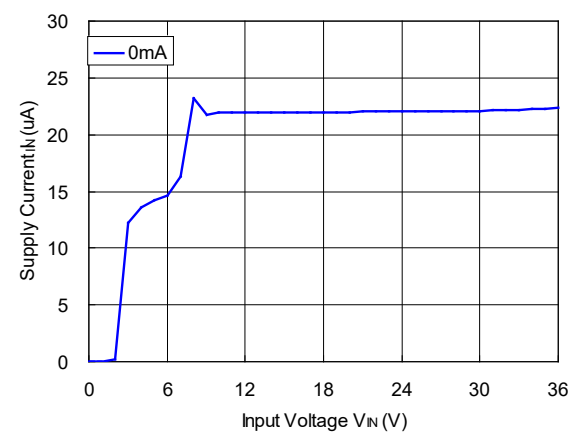

## 4) Output Voltage vs. Operating Temperature

R1517x25xx, R1517x001C

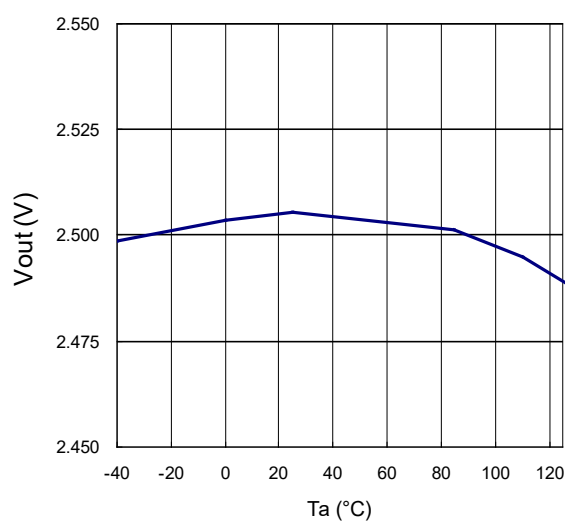

R1517x33xx

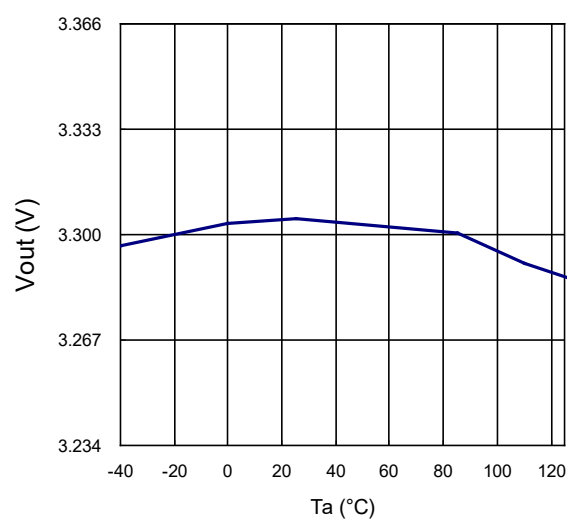

R1517x50xx

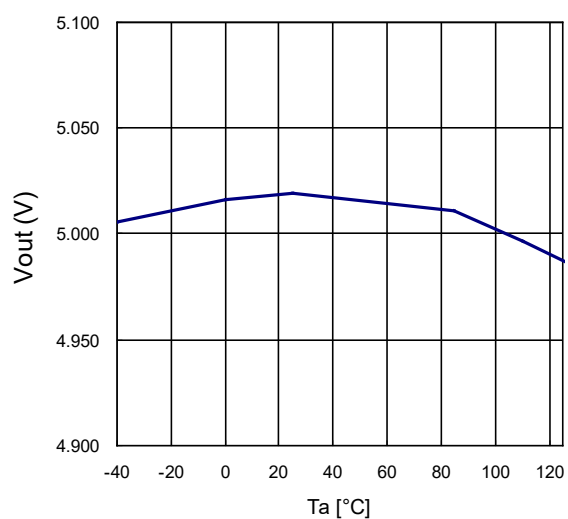

R1517x85xx

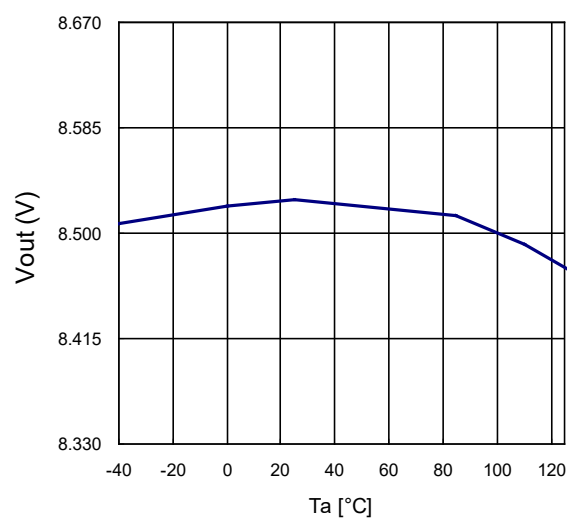

5) Dropout Voltage vs. Output Current

R1517x25xx, R1517x001C

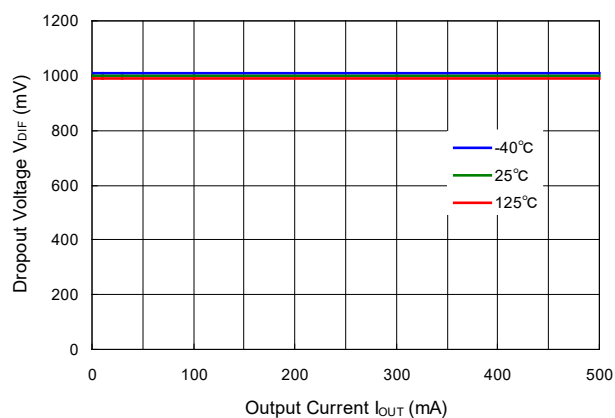

R1517x33xx

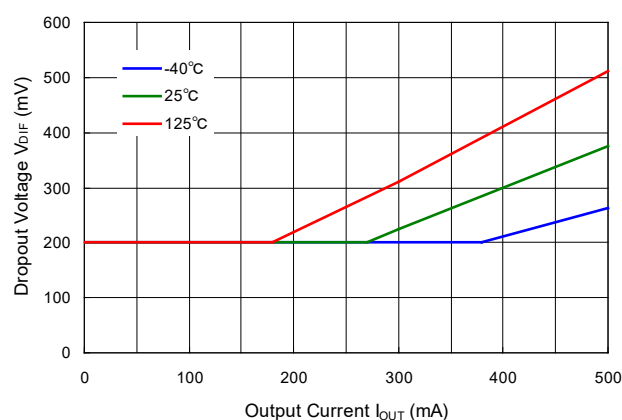

R1517x50xx

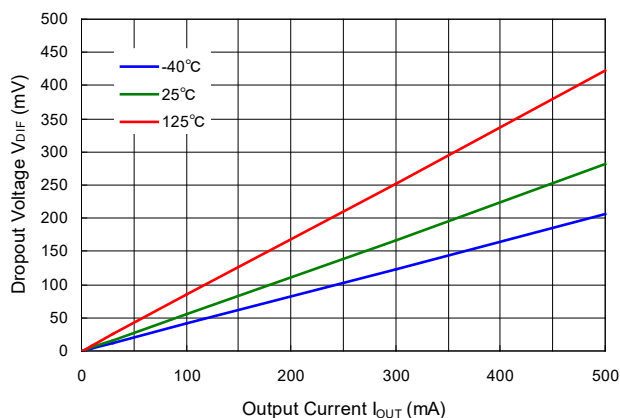

R1517x85xx

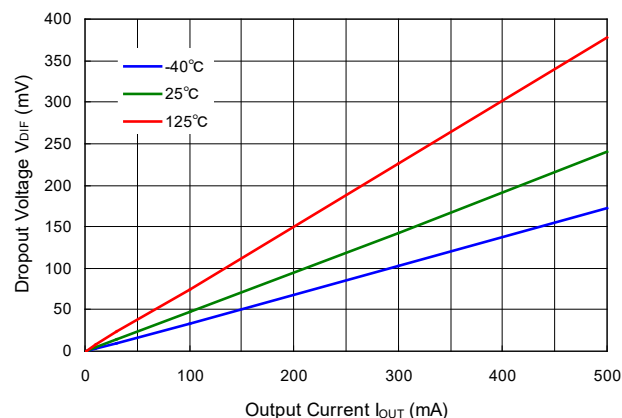

6) Ripple Rejection vs. Input Voltage (Ta = 25°C, Ripple = 0.5 Vpp)

R1517x25xx, R1517x001C (I\_OUT = 1 mA)

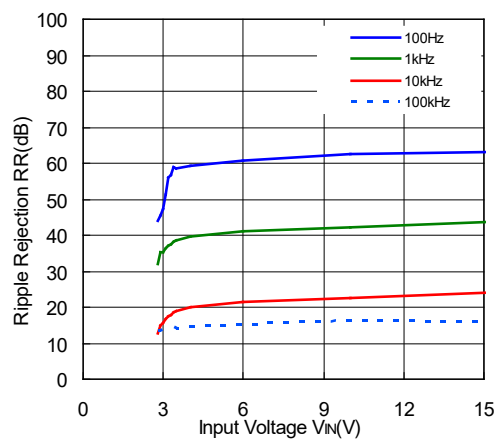

R1517x25xx, R1517x001C (I\_OUT = 150 mA)

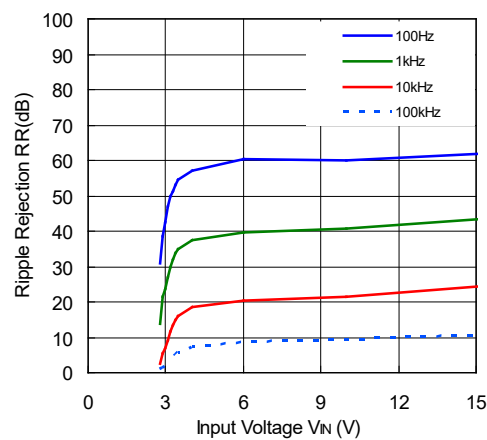

R1517x33xx (I<sub>OUT</sub> = 1 mA)

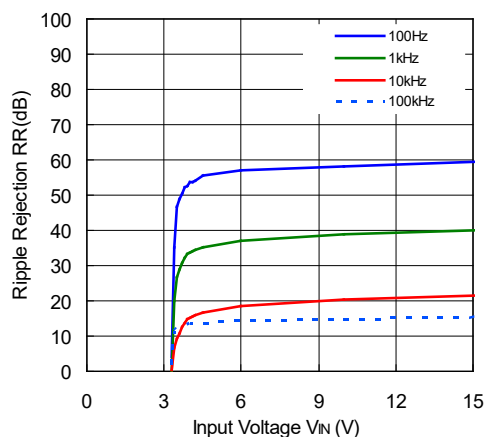

R1517x33xx (I<sub>OUT</sub> = 150 mA)

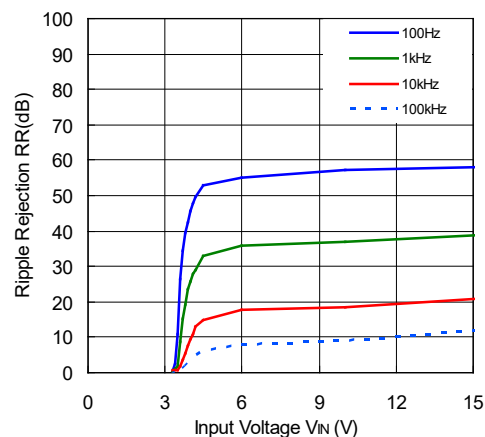

R1517x50xx (I<sub>OUT</sub> = 1 mA)

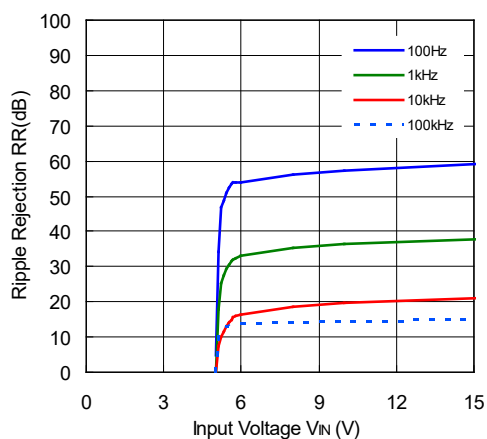

R1517x50xx (I<sub>OUT</sub> = 150 mA)

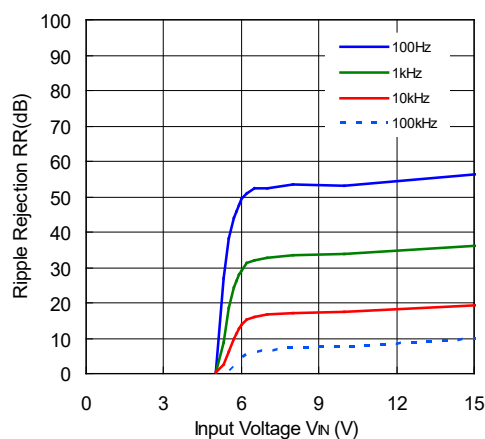

R1517x85xx (I<sub>OUT</sub> = 1 mA)

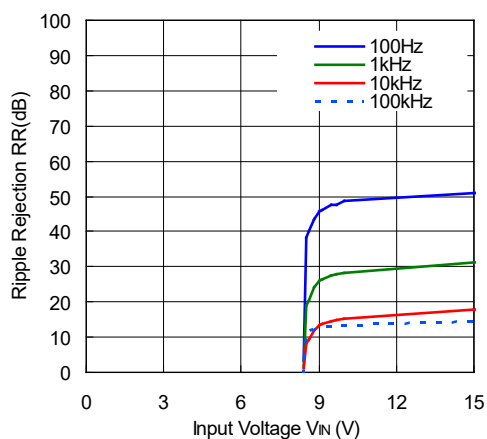

R1517x85xx (I<sub>OUT</sub> = 150 mA)

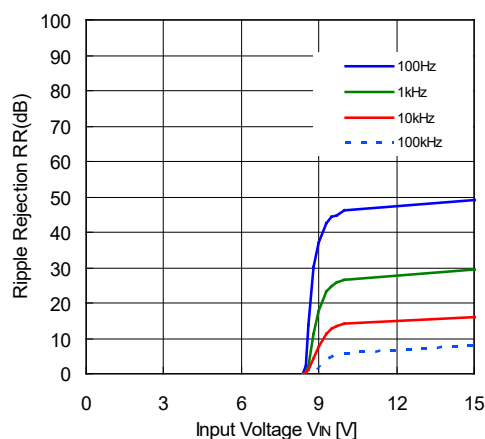

7) Ripple Rejection vs. Frequency ( $T_a = 25^\circ\text{C}$ , Ripple = 0.5 Vpp)

R1517x25xx, R1517x001C

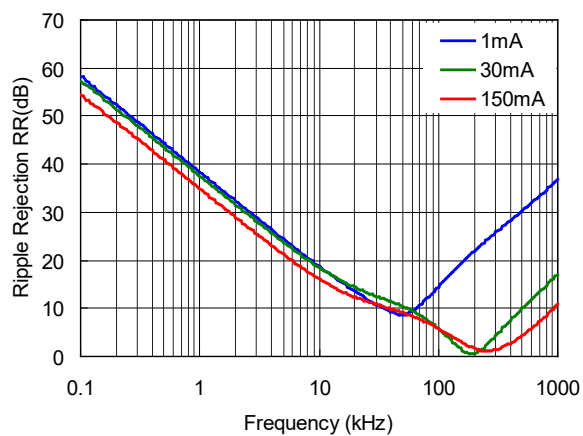

R1517x33xx

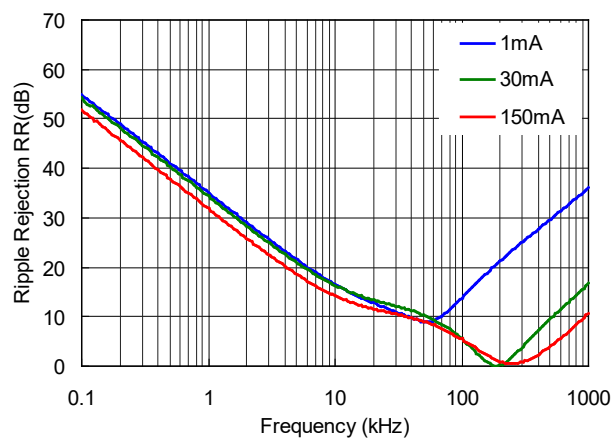

R1517x50xx

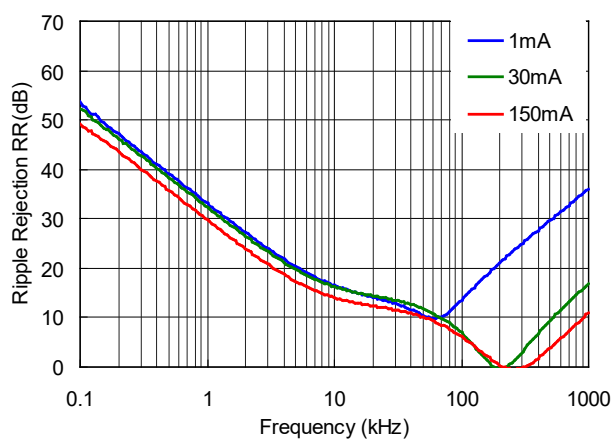

R1517x85xx

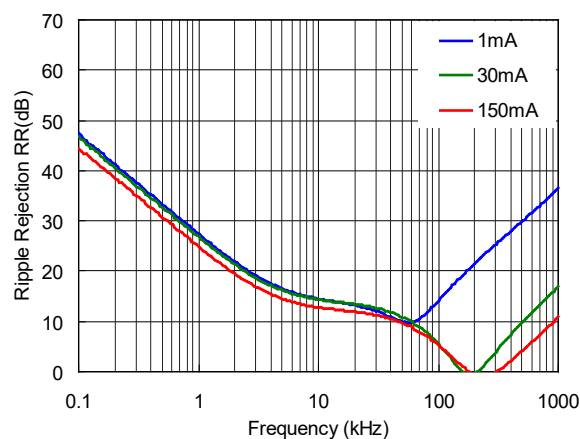

8) Input Transient Response ( $T_a = 25^\circ\text{C}$ ,  $I_{OUT} = 1\text{ mA}$ ,  $t_r = t_f = 5\ \mu\text{s}$ )

R1517x25xx, R1517x001C ( $C_2 = 0.1\ \mu\text{F}$ )

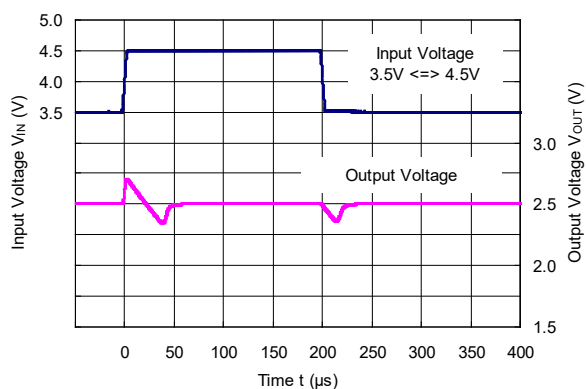

R1517x25xx, R1517x001C ( $C_2 = 10\ \mu\text{F}$ )

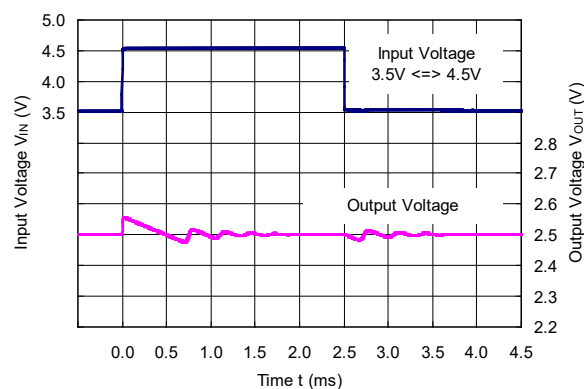

R1517x33xx (C2 = 0.1  $\mu$ F)

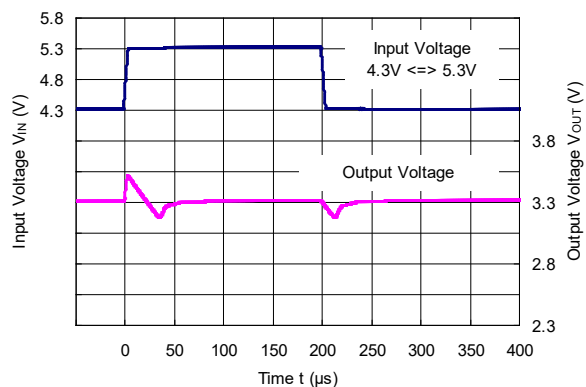

R1517x33xx (C2 = 10  $\mu$ F)

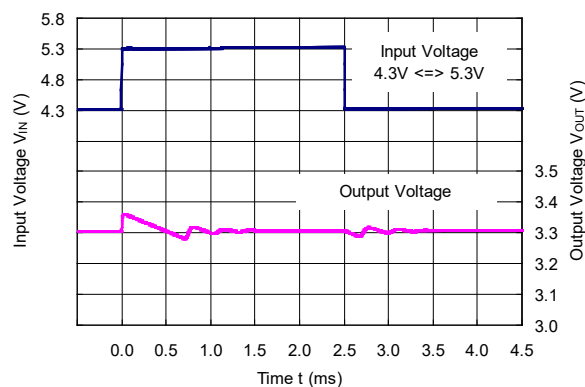

R1517x50xx (C2 = 0.1  $\mu$ F)

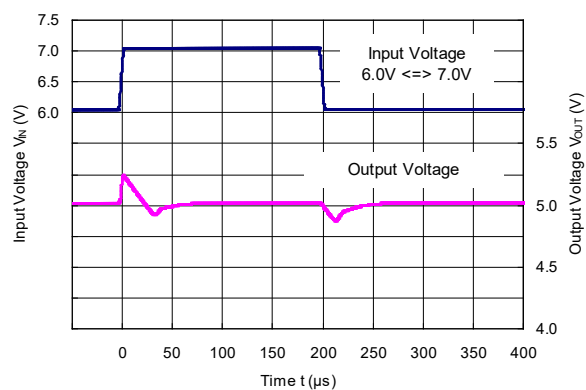

R1517x50xx (C2 = 10  $\mu$ F)

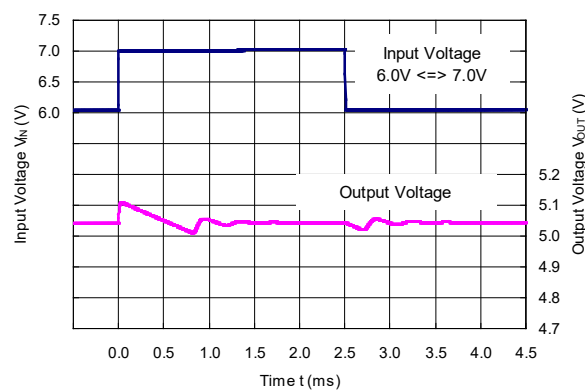

R1517x85xx (C2 = 0.1  $\mu$ F)

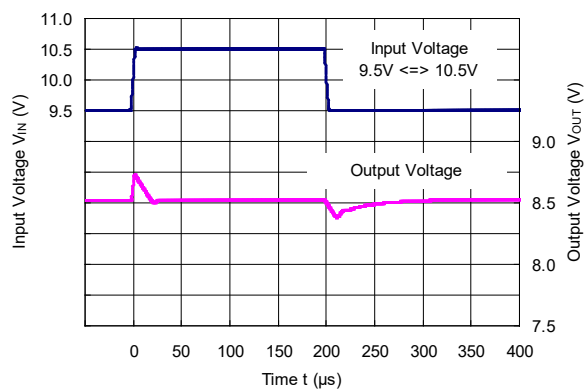

R1517x85xx (C2 = 10  $\mu$ F)

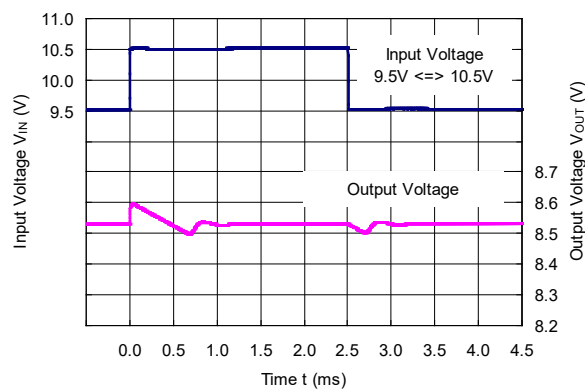

9) Load Transient Response ( $T_a = 25^\circ\text{C}$ ,  $V_{IN} = V_{OUT} + 1.0\text{ V}$ ,  $t_r = t_f = 0.5\ \mu\text{s}$ )

R1517x25xx, R1517x001C ( $C_2 = 0.1\ \mu\text{F}$ )

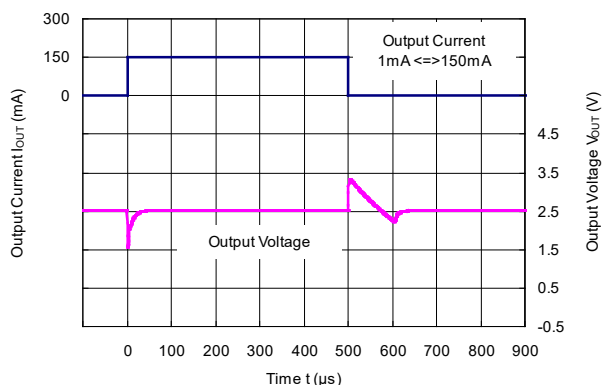

R1517x25xx, R1517x001C ( $C_2 = 10\ \mu\text{F}$ )

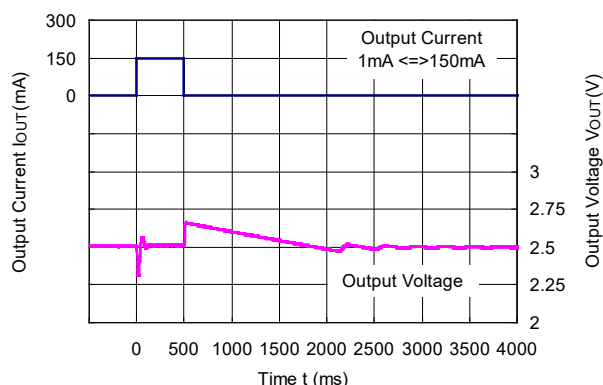

R1517x33xx ( $C_2 = 0.1\ \mu\text{F}$ )

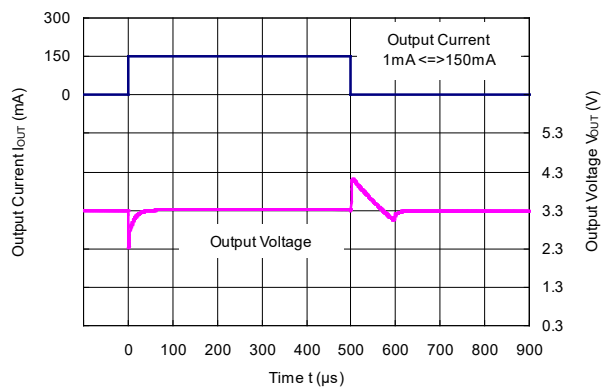

R1517x33xx ( $C_2 = 10\ \mu\text{F}$ )

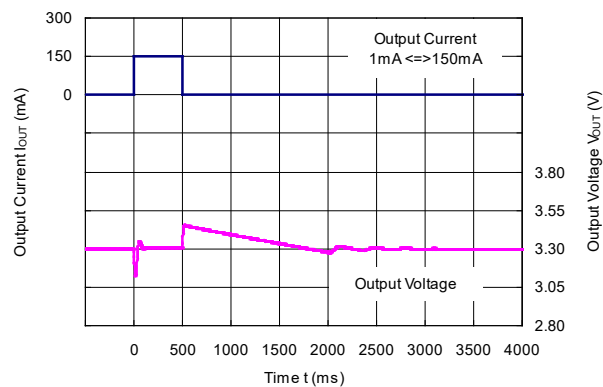

R1517x50xx ( $C_2 = 0.1\ \mu\text{F}$ )

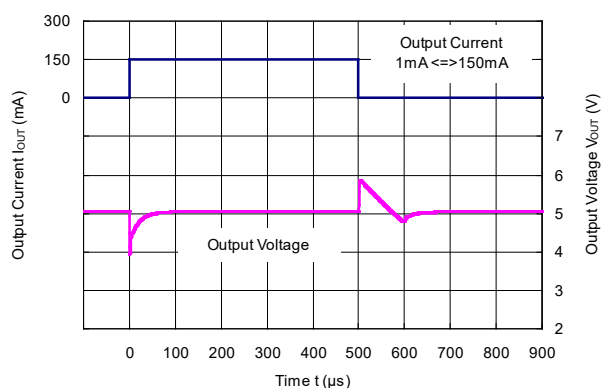

R1517x50xx ( $C_2 = 10\ \mu\text{F}$ )

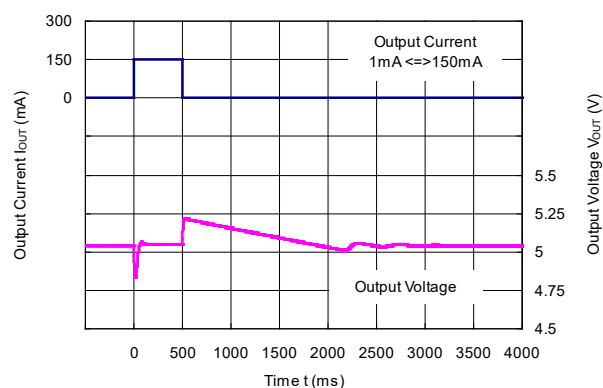



R1517x85xx (C2 = 0.1  $\mu$ F)

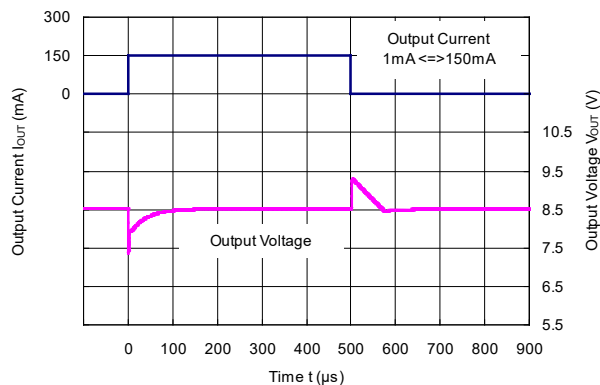

R1517x85xx (C2 = 10  $\mu$ F)

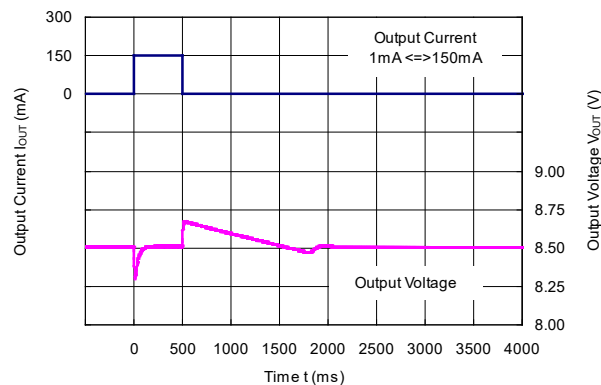

10) CE Transient Response ( $T_a = 25^\circ\text{C}$ ,  $I_{OUT} = 1 \text{ mA}$ )

R1517x25xB/D, R1517x001C (C2 = 0.1  $\mu$ F)

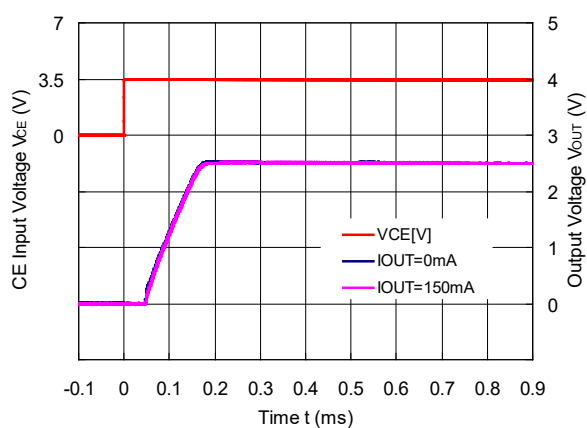

R1517x25xD (C2 = 0.1  $\mu$ F)

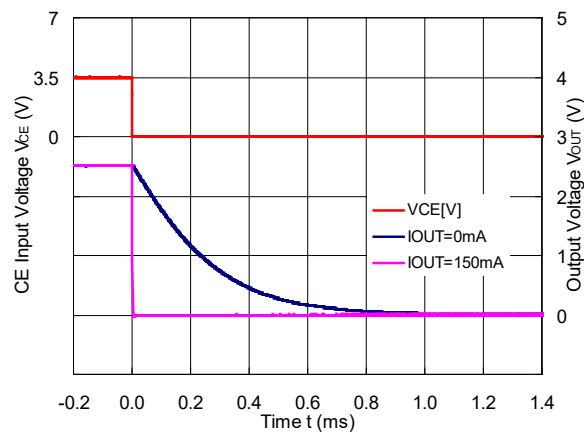

R1517x33xB/D (C2 = 0.1  $\mu$ F)

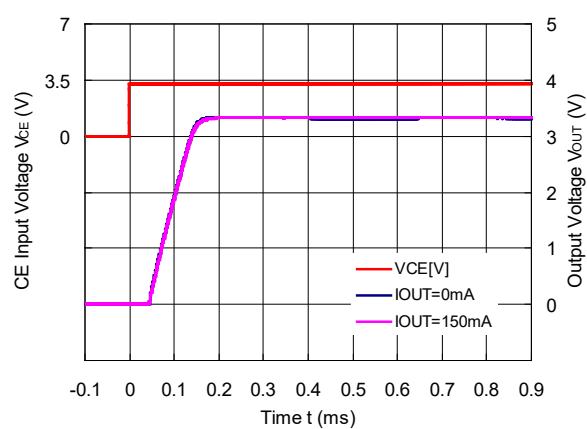

R1517x33xD (C2 = 0.1  $\mu$ F)

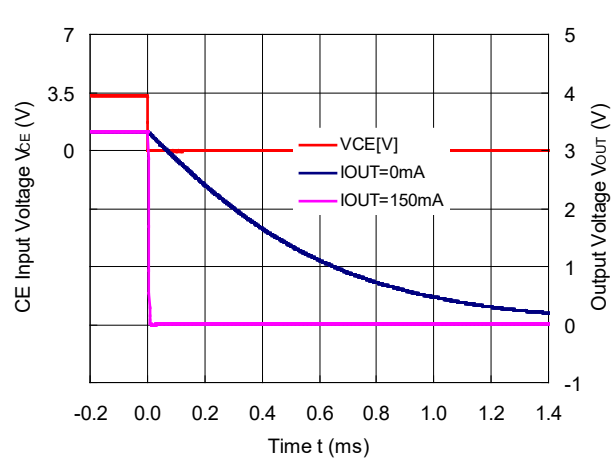

R1517x50xB/D (C2 = 0.1 μF)

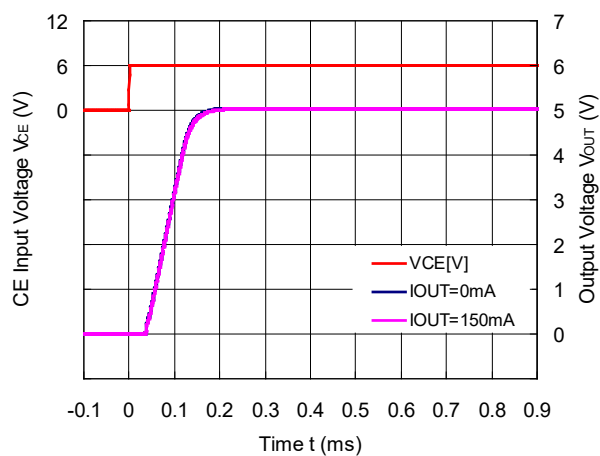

R1517x50xD (C2 = 0.1 μF)

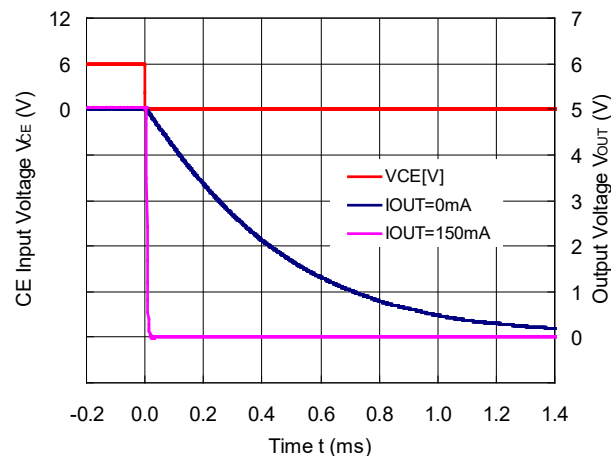

R1517x85xB/D (C2 = 0.1 μF)

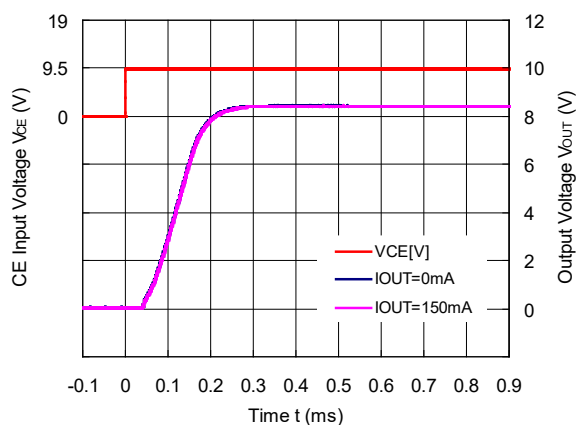

R1517x85xD (C2 = 0.1 μF)

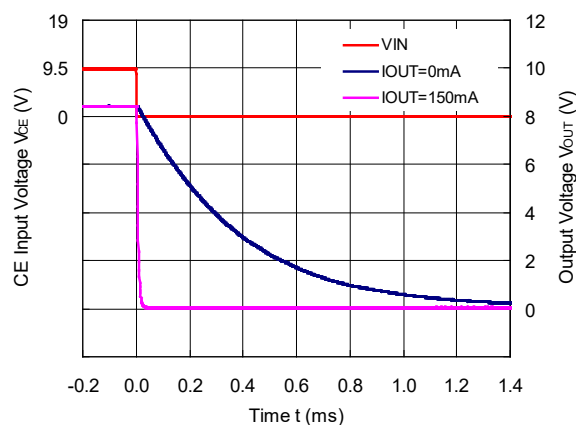

R1517J251E/F (C2 = 0.1 μF, CD = 1 nF)

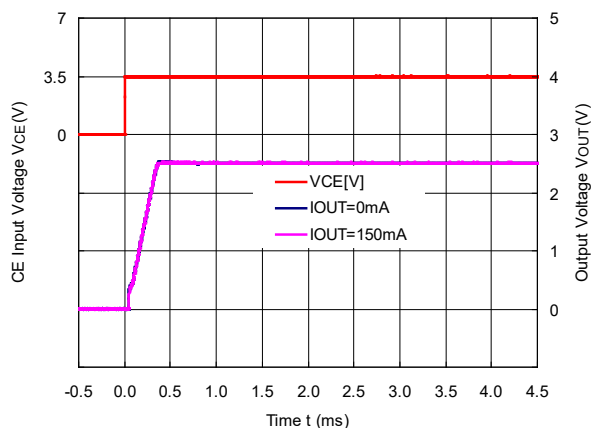

R1517J251F (C2 = 0.1 μF, CD = 1 nF)

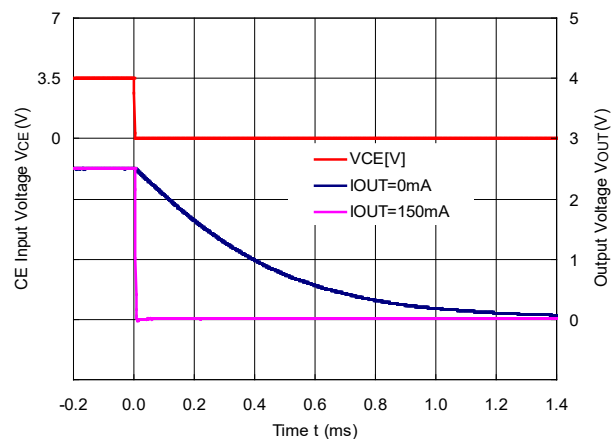

R1517J331E/F (C2 = 0.1 μF, CD = 1 nF)

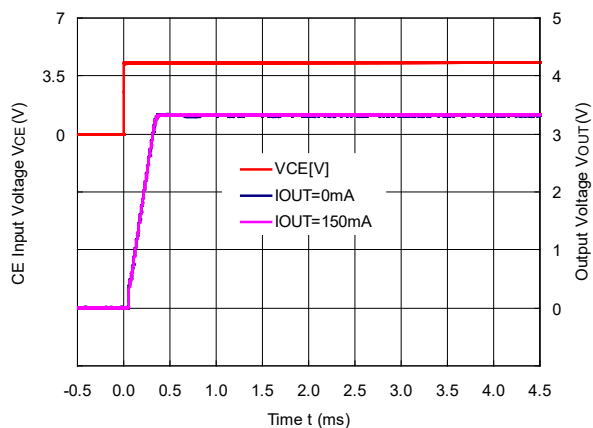

R1517J331F (C2 = 0.1 μF, CD = 1 nF)

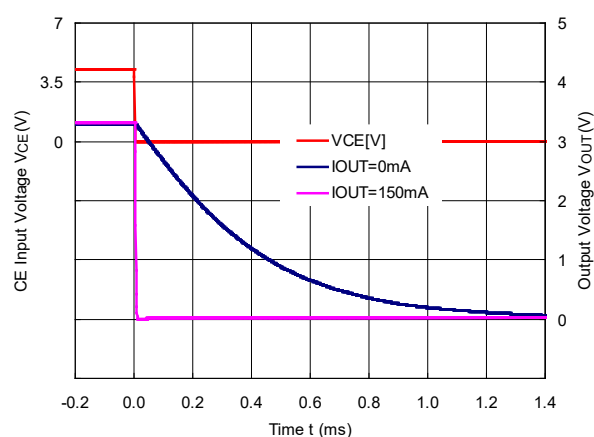

R1517J501E/F (C2 = 0.1 μF, CD = 1 nF)

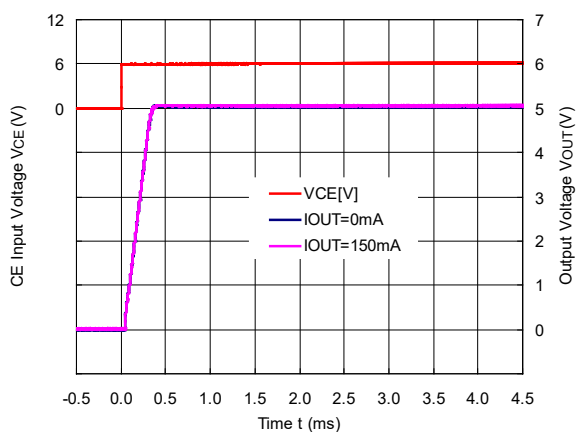

R1517J501F (C2 = 0.1 μF, CD = 1 nF)

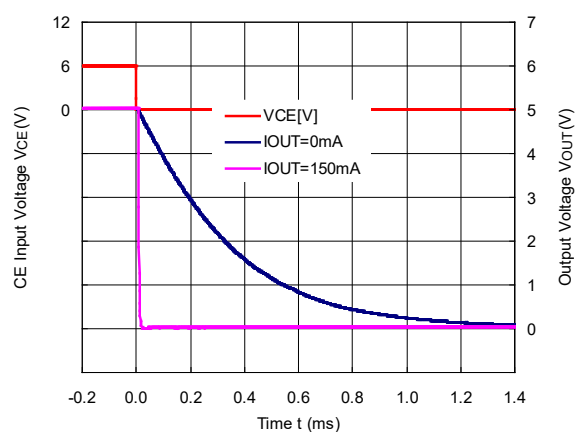

R1517J851E/F (C2 = 0.1 μF, CD = 1 nF)

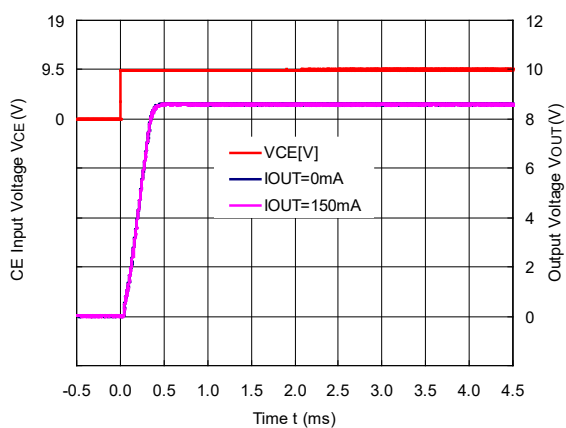

R1517J851F (C2 = 0.1 μF, CD = 1 nF)

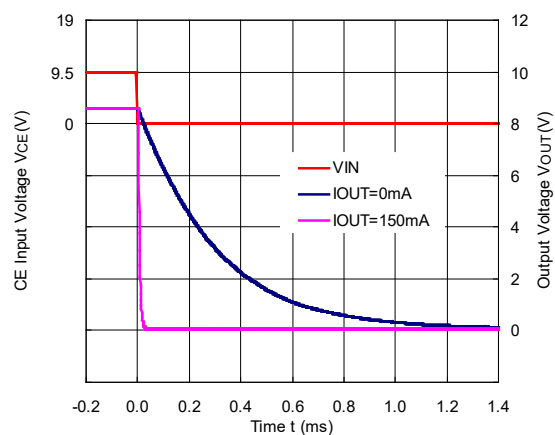

11) Inrush Current Prevention Circuit (Ta = 25°C, I<sub>OUT</sub> = 1 mA)

R1517x25xB/D, R1517x001C

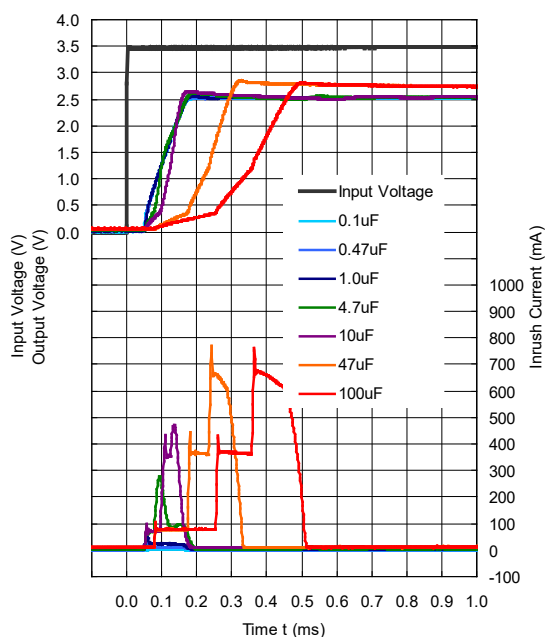

R1517x33xB/D

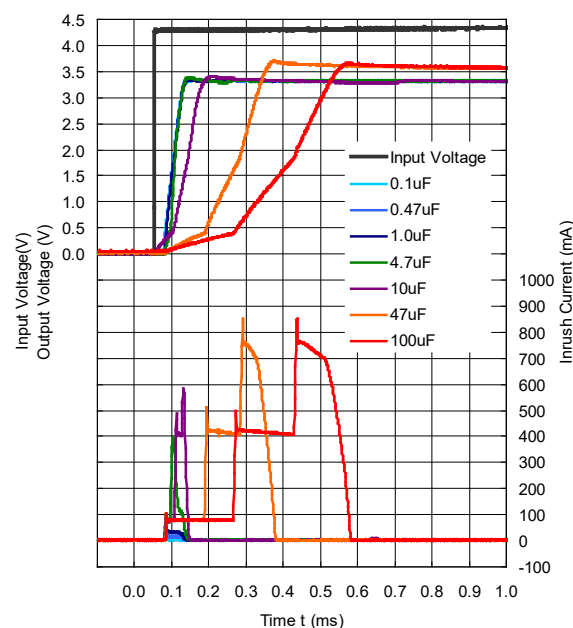

R1517x50xB/D

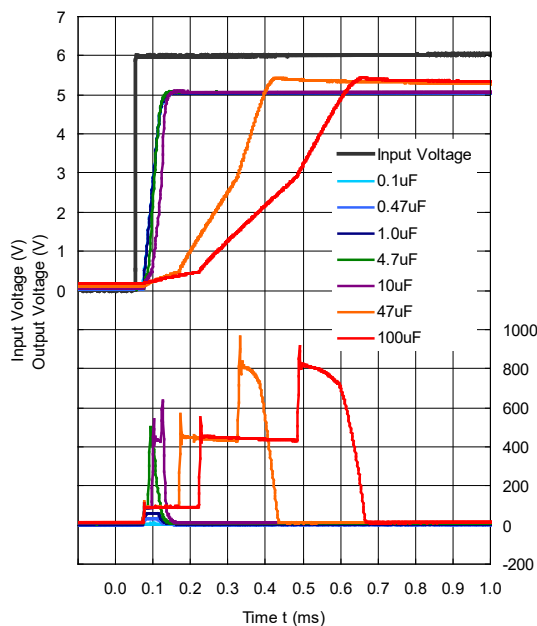

R1517x85xB/D

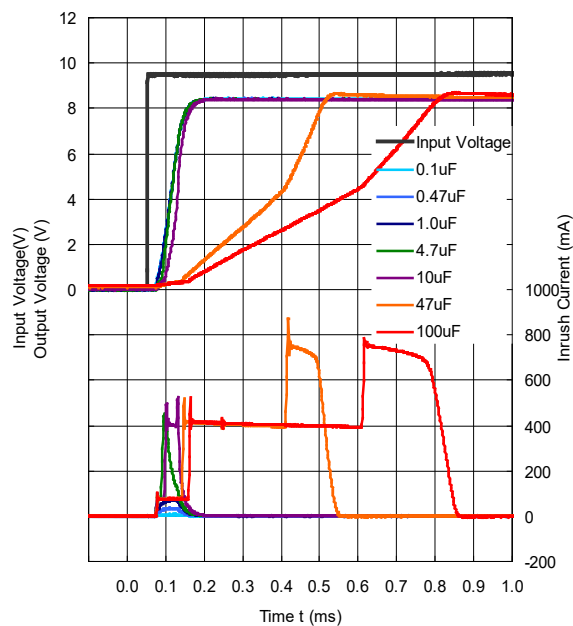

R1517J251E/F ( $C_D = 10\text{ nF}$ )

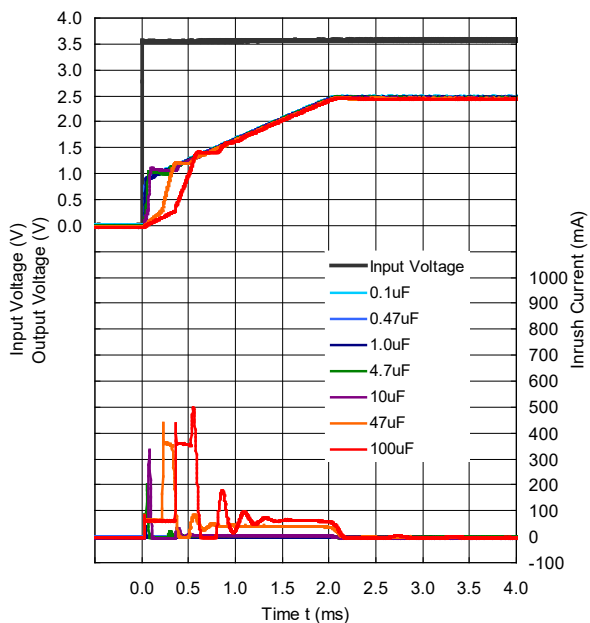

R1517J331E/F ( $C_D = 10\text{ nF}$ )

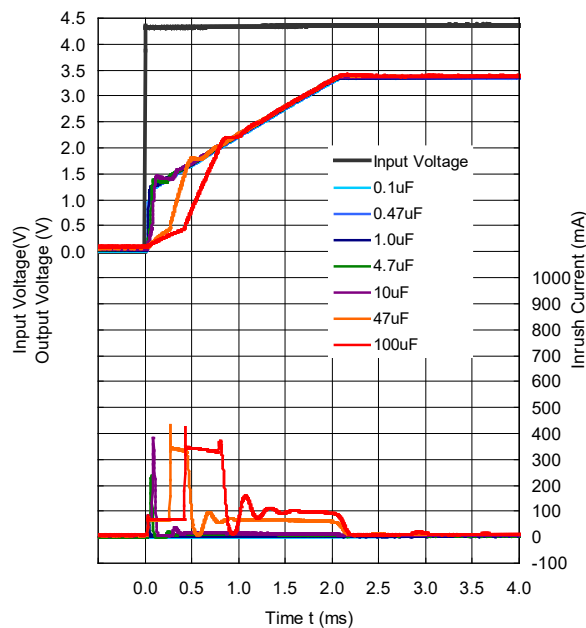

R1517J501E/F ( $C_D = 10\text{ nF}$ )

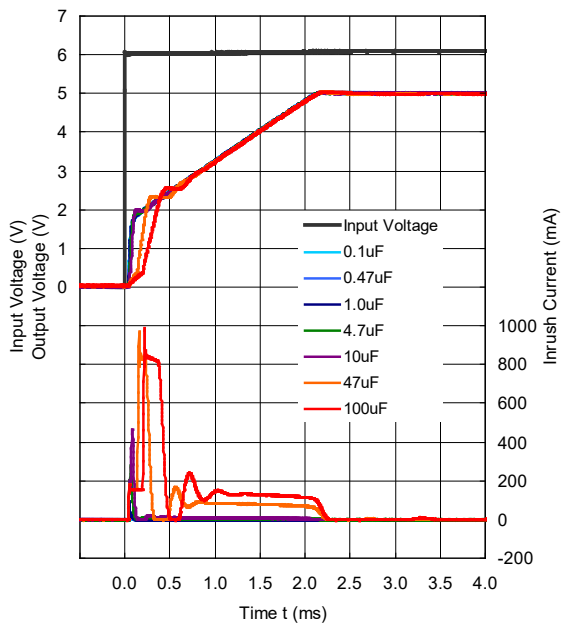

R1517J851E/F ( $C_D = 10\text{ nF}$ )

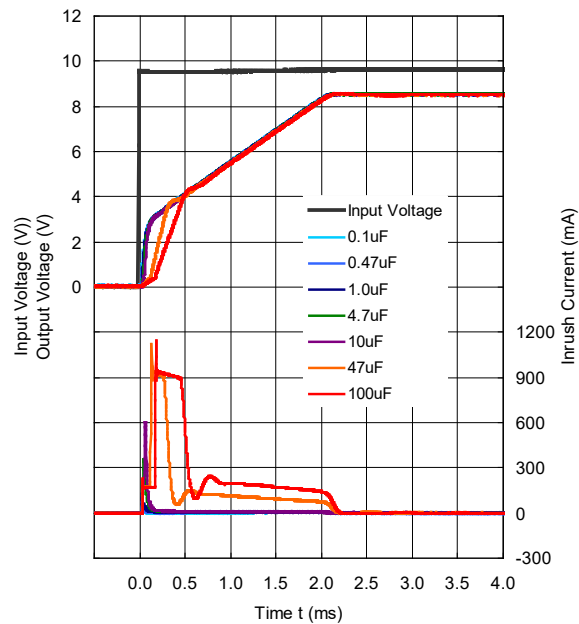



## ESR vs. Output Current

It is recommended that a ceramic type capacitor be used for this device. However, other types of capacitors having lower ESR can also be used. The relation between the output current ( $I_{OUT}$ ) and the ESR of output capacitor is shown below.

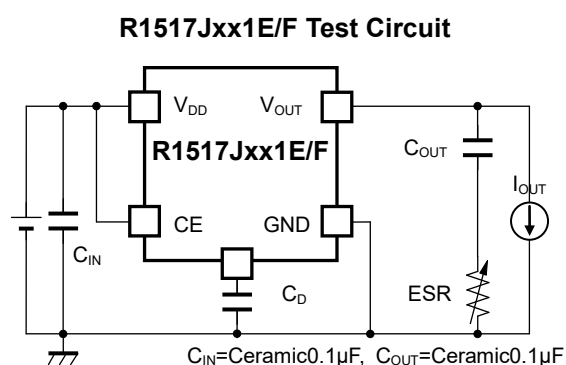
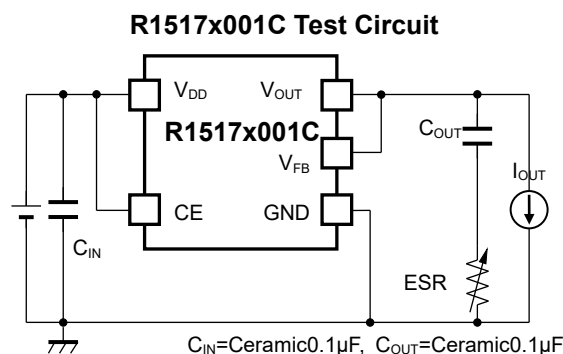
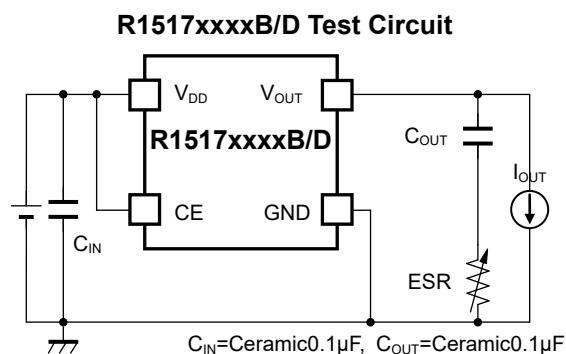

### Measurement conditions

Frequency Band: 10 Hz to 2 MHz

Measurement Temperature:  $-40^{\circ}\text{C}$  to  $125^{\circ}\text{C}$

Hatched area: Noise level is  $40\mu\text{V}$  (average) or below

Capacitor: C1 = Ceramic  $0.1\mu\text{F}$ , C2 =  $0.1\mu\text{F}$

**R1517x25xx Output Current  $I_{OUT}$  vs. ESR**

$V_{IN} = 2.5\text{V to } 36\text{V}$

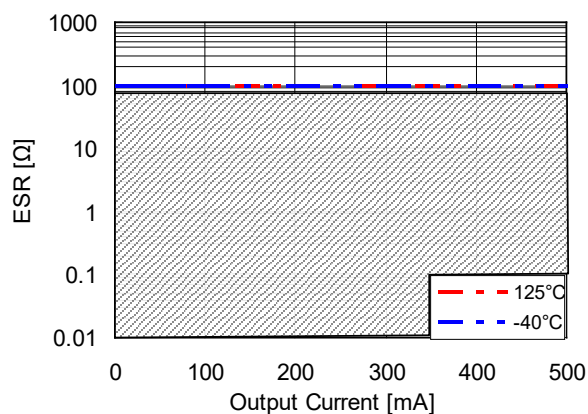

**R1517x85xx Output Current  $I_{OUT}$  vs. ESR**

$V_{IN} = 8.5\text{V to } 36\text{V}$

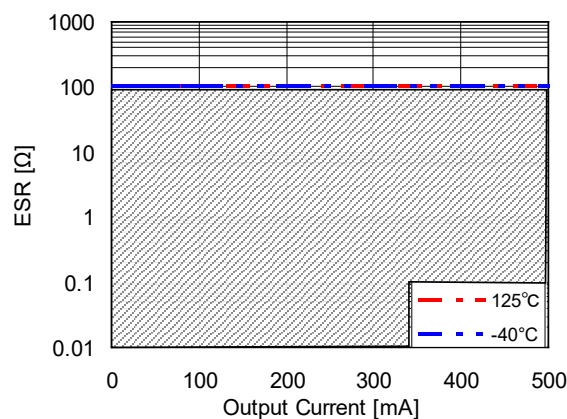



1. The products and the product specifications described in this document are subject to change or discontinuation of production without notice for reasons such as improvement. Therefore, before deciding to use the products, please refer to Ricoh sales representatives for the latest information thereon.
2. The materials in this document may not be copied or otherwise reproduced in whole or in part without prior written consent of Ricoh.
3. Please be sure to take any necessary formalities under relevant laws or regulations before exporting or otherwise taking out of your country the products or the technical information described herein.
4. The technical information described in this document shows typical characteristics of and example application circuits for the products. The release of such information is not to be construed as a warranty of or a grant of license under Ricoh's or any third party's intellectual property rights or any other rights.
5. The products in this document are designed for automotive applications. However, when using the products for automotive applications, please make sure to contact Ricoh sales representative in advance due to confirming the quality level.
6. We are making our continuous effort to improve the quality and reliability of our products, but semiconductor products are likely to fail with certain probability. In order to prevent any injury to persons or damages to property resulting from such failure, customers should be careful enough to incorporate safety measures in their design, such as redundancy feature, fire containment feature and fail-safe feature. We do not assume any liability or responsibility for any loss or damage arising from misuse or inappropriate use of the products.
7. Anti-radiation design is not implemented in the products described in this document.
8. The X-ray exposure can influence functions and characteristics of the products. Confirm the product functions and characteristics in the evaluation stage.
9. WLCSP products should be used in light shielded environments. The light exposure can influence functions and characteristics of the products under operation or storage.
10. There can be variation in the marking when different AOI (Automated Optical Inspection) equipment is used.  
In the case of recognizing the marking characteristic with AOI, please contact Ricoh sales or our distributor before attempting to use AOI.
11. Please contact Ricoh sales representatives should you have any questions or comments concerning the products or the technical information.



**Ricoh is committed to reducing the environmental loading materials in electrical devices with a view to contributing to the protection of human health and the environment.**

Ricoh has been providing RoHS compliant products since April 1, 2006 and Halogen-free products since April 1, 2012.

**RICOH** RICOH ELECTRONIC DEVICES CO., LTD.

**Official website**

<https://www.n-redc.co.jp/en/>

**Contact us**

<https://www.n-redc.co.jp/en/buy/>

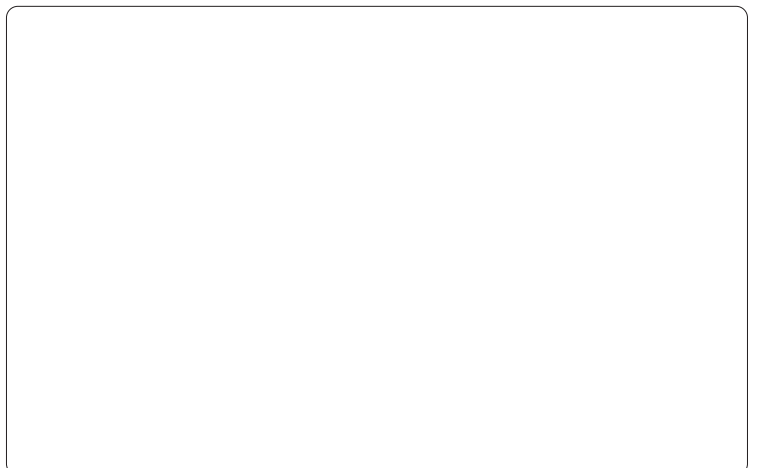



## X-ON Electronics

Largest Supplier of Electrical and Electronic Components

*Click to view similar products for [LDO Voltage Regulators](#) category:*

*Click to view products by [Nisshinbo](#) manufacturer:*

Other Similar products are found below :

[AP7363-SP-13](#) [L79M05TL-E](#) [TCR3DF185,LM\(CT](#) [TCR3DF24,LM\(CT](#) [TCR3DF285,LM\(CT](#) [TCR3DF31,LM\(CT](#) [TCR3DF45,LM\(CT](#)  
[MP2013GQ-33-Z](#) [059985X](#) [NCP4687DH15T1G](#) [701326R](#) [TCR2EN28,LF\(S](#) [NCV8170AXV250T2G](#) [TCR3DF27,LM\(CT](#)  
[TCR3DF19,LM\(CT](#) [TCR3DF125,LM\(CT](#) [TCR2EN18,LF\(S](#) [AP2112R5A-3.3TRG1](#) [AP7315-25W5-7](#) [IFX30081LDVGRNXUMA1](#)  
[NCV47411PAAJR2G](#) [AP2113KTR-G1](#) [AP2111H-1.2TRG1](#) [ZLDO1117QK50TC](#) [AZ1117IH-1.8TRG1](#) [AZ1117ID-ADJTRG1](#)  
[TCR3DG12,LF](#) [MIC5514-3.3YMT-T5](#) [MIC5512-1.2YMT-T5](#) [MIC5317-2.8YM5-T5](#) [SCD7912BTG](#) [NCP154MX180270TAG](#) [SCD33269T-](#)  
[5.0G](#) [NCV8170BMX330TCG](#) [NCV8170AMX120TCG](#) [NCP706ABMX300TAG](#) [NCP153MX330180TCG](#) [NCP114BMX075TCG](#)  
[MC33269T-3.5G](#) [CAT6243-ADJCMT5T](#) [TCR3DG33,LF](#) [AP2127N-1.0TRG1](#) [TCR4DG35,LF](#) [LT1117CST-3.3](#) [TAR5S15U\(TE85L,F\)](#)  
[TAR5S18U\(TE85L,F\)](#) [TCR3UG19A,LF](#) [TCR4DG105,LF](#) [NCV8170AMX360TCG](#) [MIC94310-NYMT-T5](#)