

RICOH

R2033x

3 wire interface Real-Time Clock ICs

NO.EA-120-160701

OUTLINE

The R2033x is a CMOS real-time clock IC connected to the CPU by three signal lines, CE, SCLK, SIO, and configured to perform serial transmission of time and calendar data to the CPU. The periodic interrupt circuit is configured to generate interrupt signals with six selectable interrupts ranging from 0.5 seconds to 1 month. The 2 alarm interrupt circuits generate interrupt signals at preset times. As the oscillation circuit is driven under constant voltage, fluctuation of the oscillator frequency due to supply voltage is small, and the time keeping current is small (TYP. 0.45 μ A at 3V). The oscillation halt sensing circuit can be used to judge the validity of internal data in such events as power-on; The supply voltage monitoring circuit is configured to record a drop in supply voltage below two selectable supply voltage monitoring threshold settings. The 32.768kHz clock output function (CMOS output with control pin) is intended to output sub-clock pulses for the external microcomputer. The oscillation adjustment circuit is intended to adjust time counts with high precision by correcting deviations in the oscillation frequency of the crystal oscillator. Since the package for these ICs are TSSOP10G (4.0x2.9x1.0: R2033T) or QFN023023-16(2.3mm x 2.3mm x 0.4mm:R2033L), high density mounting of ICs on boards is possible.

FEATURES

- Minimum Timekeeping supply voltage TYP:0.66 to 5.5v (Worst: 1.00V to 5.5v); VDD pin
- Low power consumption 0.45 μ A TYP at VDD=3V (1.00 μ A MAX.)
- Three signal lines (CE, SCLK, SIO) required for connection to the CPU.
(Maximum clock frequency of 1MHz (with V_{DD} = 3V))
- Time counters (counting hours, minutes, and seconds) and calendar counters (counting years, months, days, and weeks) (in BCD format)
- Interrupt circuit configured to generate interrupt signals (with interrupts ranging from 0.5 seconds to 1 month) to the CPU and provided with an interrupt flag and an interrupt halt
- 2 alarm interrupt circuits (Alarm_W for week, hour, and minute alarm settings and Alarm_D for hour and minute alarm settings)
- With Power-on flag to prove that the power supply starts from 0V
- 32-kHz clock output pin (CMOS push-pull output with control pin)
- Supply voltage monitoring circuit with two supply voltage monitoring threshold settings
- Automatic identification of leap years up to the year 2099
- Selectable 12-hour and 24-hour mode settings
- High precision oscillation adjustment circuit
- Built-in oscillation stabilization capacitors (CG and CD)
- Package TSSOP10G (4.0mm x 2.9mm x 1.0mm: R2033T)
FFP12 (2.0mm x 2.0mm x 1.0mm: R2033K)
QFN023023-16(2.3mm x 2.3mm x 0.4mm:R2033L)
- CMOS process

* R2033K (FFP12) is the discontinued product as of July, 2016.

R2033x

NO.EA-120-160701

PIN CONFIGURATION

R2033T(TSSOP10G)

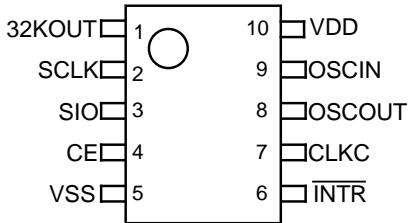

TOP VIEW

R2033K(FFP12)
Discontinued

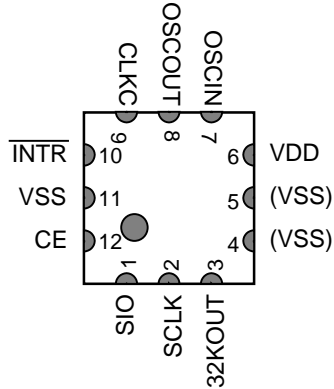

TOP VIEW

R2033L(QFN023023-16)

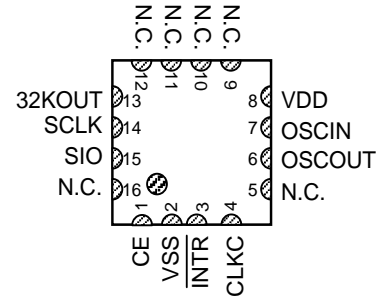

TOP VIEW

BLOCK DIAGRAM

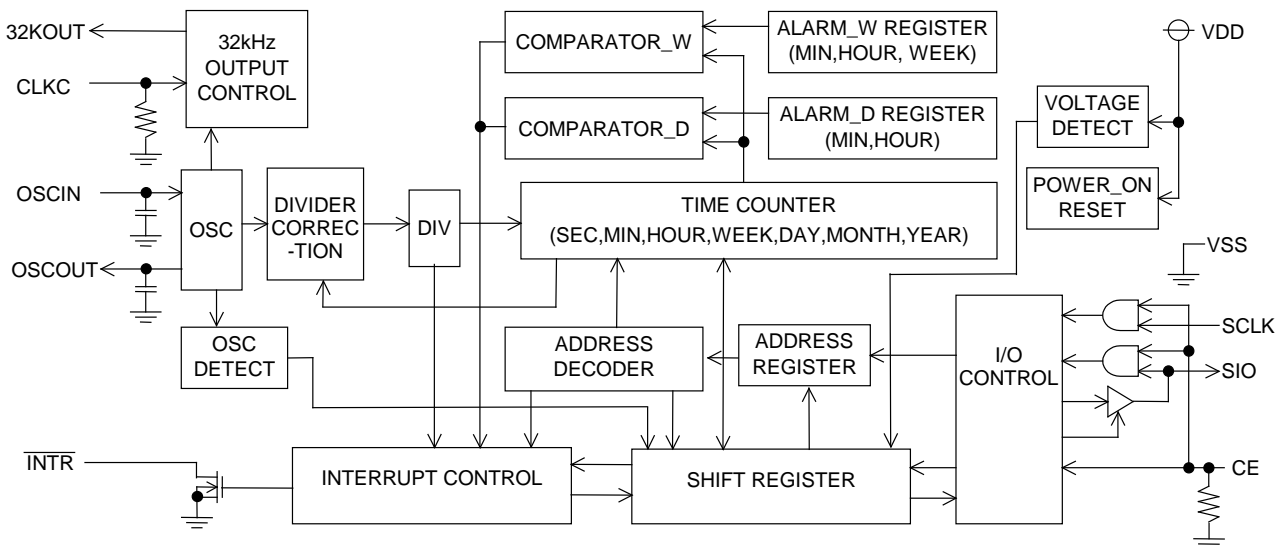

SELECTION GUIDE

Part Number is designated as follows:

R2033 L - E2 - F ← Part Number

↑ ↑ ↑

R2033 a - bb - c

Code	Description
a	Designation of the package. K : FFP12 T : TSSOP10G L : QFN023023-16
bb	Designation of the taping type. Only E2 is available.
c	Designation of the lead plating (TSSOP10G only). F: Lead free plating

RICOH

PIN DESCRIPTION

Symbol	Item	Description
CE	Chip enable Input	The CE pin is used for interfacing with the CPU. Should be held high to allow access to the CPU. Incorporates a pull-down resistor. Should be held low or open when the CPU is powered off. Allows a maximum input voltage of 5.5v regardless of supply voltage.
SCLK	Serial Clock Input	The SCLK pin is used to input clock pulses synchronizing the input and output of data to and from the SIO pin. Allows a maximum input voltage of 5.5v regardless of supply voltage.
SIO	Serial Input / Output	The SIO pin is used to input and output data intended for writing and reading in synchronization with the SCLK pin. CMOS input / output.
$\overline{\text{INTR}}$	Interrupt Output	The $\overline{\text{INTR}}$ pin is used to output alarm interrupt (Alarm_W) and alarm interrupt (Alarm_D) and output periodic interrupt signals to the CPU. Disabled at power-on from 0V. N-channel open drain output. Allows a maximum pull-up voltage of 5.5v regardless of supply voltage.
32KOUT	32kHz Clock Output	The 32KOUT pin is used to output 32.768-kHz clock pulses. The pin is CMOS push-pull output. The output is disabled and held "L" when CLKC pin is set to "L" or open, or certain register setting. This pin is enabled at power-on from 0v.
CLKC	Clock Control	The CLKC pin is used to control output of the 32KOUT pin. The clock output is disabled and held "L" when this pin is set to "L" or open. Incorporated pull down register.
OSCIN OSCOUT	Oscillation Circuit Input / Output	The OSCIN and OSCOUT pins are used to connect the 32.768-kHz crystal oscillator (with all other oscillation circuit components built into the R2033x).
VDD VSS	Positive/Negative Power Supply Input	The VDD pin is connected to the power supply. The VSS pin is grounded.
(VSS)		Please connect to ground line, or do not connect any lines.
N.C.		No Connection

* R2033K (FFP12) is the discontinued product as of July, 2016.

R2033x

NO.EA-120-160701

ABSOLUTE MAXIMUM RATINGS

(V_{SS}=0V)

Symbol	Item	Pin Name	Description	Unit
V _{DD}	Supply Voltage	VDD	-0.3 to +6.5	V
V _i	Input Voltage 1	CE, SCLK, CLKC	-0.3 to +6.5	V
	Input Voltage 2	SIO	-0.3 to V _{DD} + 0.3	
V _o	Output Voltage 1	SIO, 32KOUT	-0.3 to V _{DD} + 0.3	V
	Output Voltage 2	$\overline{\text{INTR}}$	-0.3 to +6.5	
P _d	Power Dissipation	Topt = 25°C	300	mW
Topt	Operating Temperature		-40 to +85	°C
Tstg	Storage Temperature		-55 to +125	°C

RECOMMENDED OPERATING CONDITIONS

(V_{SS}=0V, Topt=-40 to +85°C)

Symbol	Item	Pin Name	Min.	Typ.	Max.	Unit
V _{access}	Supply Voltage	Power supply voltage for interfacing with CPU	1.7		5.5	V
V _{CLK}	Time keeping Voltage	CGout, CDout=0pF *1), *2)	1.00		5.50	V
V _{CLKL}	Minimum Time keeping Voltage	CGout, CDout=0pF *1), *2)		0.66	1.00	
f _{XT}	Oscillation Frequency			32.768		kHz
V _{PUP}	Pull-up Voltage	$\overline{\text{INTR}}$			5.5	V
		32KOUT			V _{DD} + 0.3	

*1) CGout is connected between OSCIN and VSS, CDout is connected between OSCOUT and VSS.

R2033x incorporates the capacitors between OSCIN and VSS, between OSCOUT and VSS.

Then normally, CGout and CDout are not necessary. For more detail, see "P.33 •Oscillation Adjustment Circuit"

*2) Crystal oscillator: CL=6-9pF, R1=50KΩ

DC ELECTRICAL CHARACTERISTICS

• R2033x

(Unless otherwise specified:

$V_{SS}=0V$, $V_{DD}=3.0V$, $T_{opt}=-40$ to $+85^{\circ}C$, Crystal oscillator 32768Hz, $CL=7pF$, $R1=50k\Omega$)

Symbol	Item	Pin Name	Conditions	Min.	Typ.	Max.	Unit
V_{IH1}	"H" Input Voltage	CE, SCLK, CLKC	$V_{DD}=1.7$ to $5.5V$	$0.8 \times V_{DD}$		5.5	V
V_{IH2}		SIO		$0.8 \times V_{DD}$		$V_{DD}+0.3$	
V_{IL}		CE, SCLK, CLKC, SIO		-0.3		$0.2 \times V_{DD}$	
I_{OH}	"H" Output Current	SIO, 32KOUT	$V_{OH}=V_{DD}-0.5V$			-0.5	mA
I_{OL1}	"L" Output Current	\overline{INTR}	$V_{OL}=0.4V$	2.0			mA
I_{OL2}		SIO, 32KOUT		0.5			
I_{IL}	Input Leakage Current	SCLK	$V_I=5.5V$ or V_{SS} $V_{DD}=5.5V$	-1		1	μA
R_{DNCE}	Pull-down Resistance	CE		40	120	400	$k\Omega$
I_{CLKC}	Pull-down Resister Input Leakage Current	CLKC	$V_I=5.5V$		0.30	1.00	μA
I_{OZ1}	Output Off-state Current	SIO	$V_O=5.5V$ or V_{SS} $V_{DD}=5.5V$	-1		1	μA
I_{OZ2}		\overline{INTR}	$V_O=5.5V$ $V_{DD}=5.5V$	-1		1	
I_{DD}	Time Keeping Current	VDD	$V_{DD}=3V$, $CE=SCLK=SIO=CLKC$ $= \overline{INTR} =0V$ 32KOUT=OFF Output = OPEN CGout=CDOut=0pF *1)		0.45	1.00	μA
V_{DETH}	Supply Voltage Monitoring Voltage "H"	VDD	$T_{opt}=-30$ to $+70^{\circ}C$	1.45	1.60	1.75	V
V_{DETL}	Supply Voltage Monitoring Voltage "L"	VDD	$T_{opt}=-30$ to $+70^{\circ}C$	1.15	1.30	1.45	V

*1) For time keeping current when outputting 32.768kHz from the 32KOUT pin, see "P.45 TYPICAL CHARACTERISTICS". For time keeping current when CGOUT, CDOUT is not equal to 0pF, see "P.30

•Adjustment of oscillation frequency".

R2033x

NO.EA-120-160701

AC ELECTRICAL CHARACTERISTICS

Unless otherwise specified: $V_{SS}=0V, T_{opt}=-40$ to $+85^{\circ}C$

Input and Output Conditions: $V_{IH}=0.8 \times V_{DD}, V_{IL}=0.2 \times V_{DD}, V_{OH}=0.8 \times V_{DD}, V_{OL}=0.2 \times V_{DD}, CL=50pF$

Symbol	Item	Conditions	$V_{DD} \geq 1.7V$			Unit
			Min.	Typ.	Max.	
t_{CES}	CE Set-up Time		400			ns
t_{CEH}	CE Hold Time		400			ns
t_{CR}	CE Recovery Time		62			μs
f_{SCLK}	SCLK Clock Frequency				1.0	MHz
t_{CKH}	SCLK Clock "H" Time		400			ns
t_{CKL}	SCLK Clock "L" Time		400			ns
t_{CKS}	SCLK Set-up Time		200			ns
t_{RD}	Data Output Delay Time				300	ns
t_{RZ}	Data Output Floating Time				300	ns
t_{CEZ}	Data Output Delay Time After Falling of CE				300	ns
t_{DS}	Input Data Set-up Time		200			ns
t_{DH}	Input Data Hold Time		200			ns

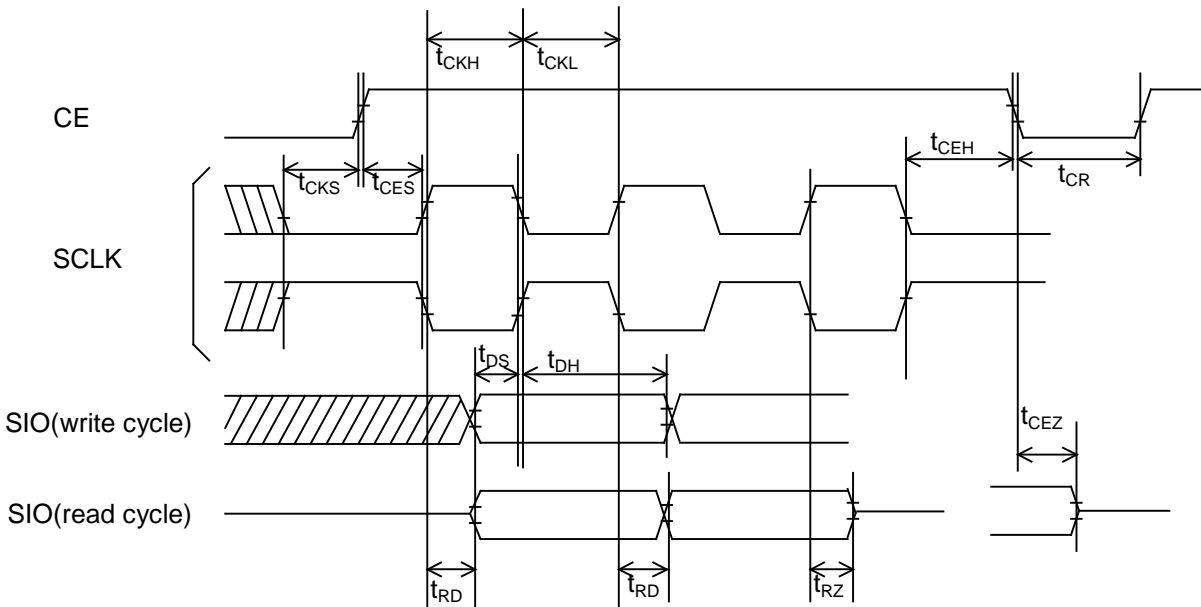

*) For reading/writing timing, see "P.27 •Considerations in Reading and Writing Time Data under special condition".

PACKAGE DIMENSIONS

- R2033K

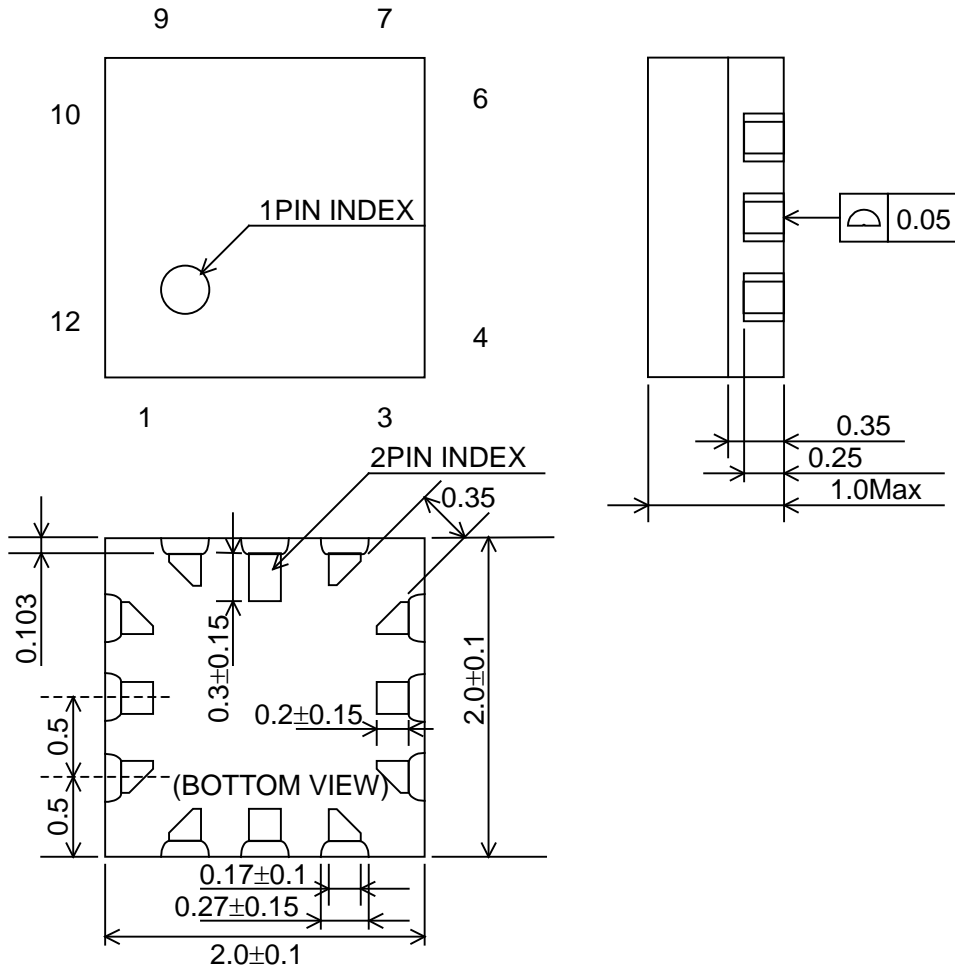

unit: mm

* R2033K (FFP12) is the discontinued product as of July, 2016.

R2033x

NO.EA-120-160701

- R2033L

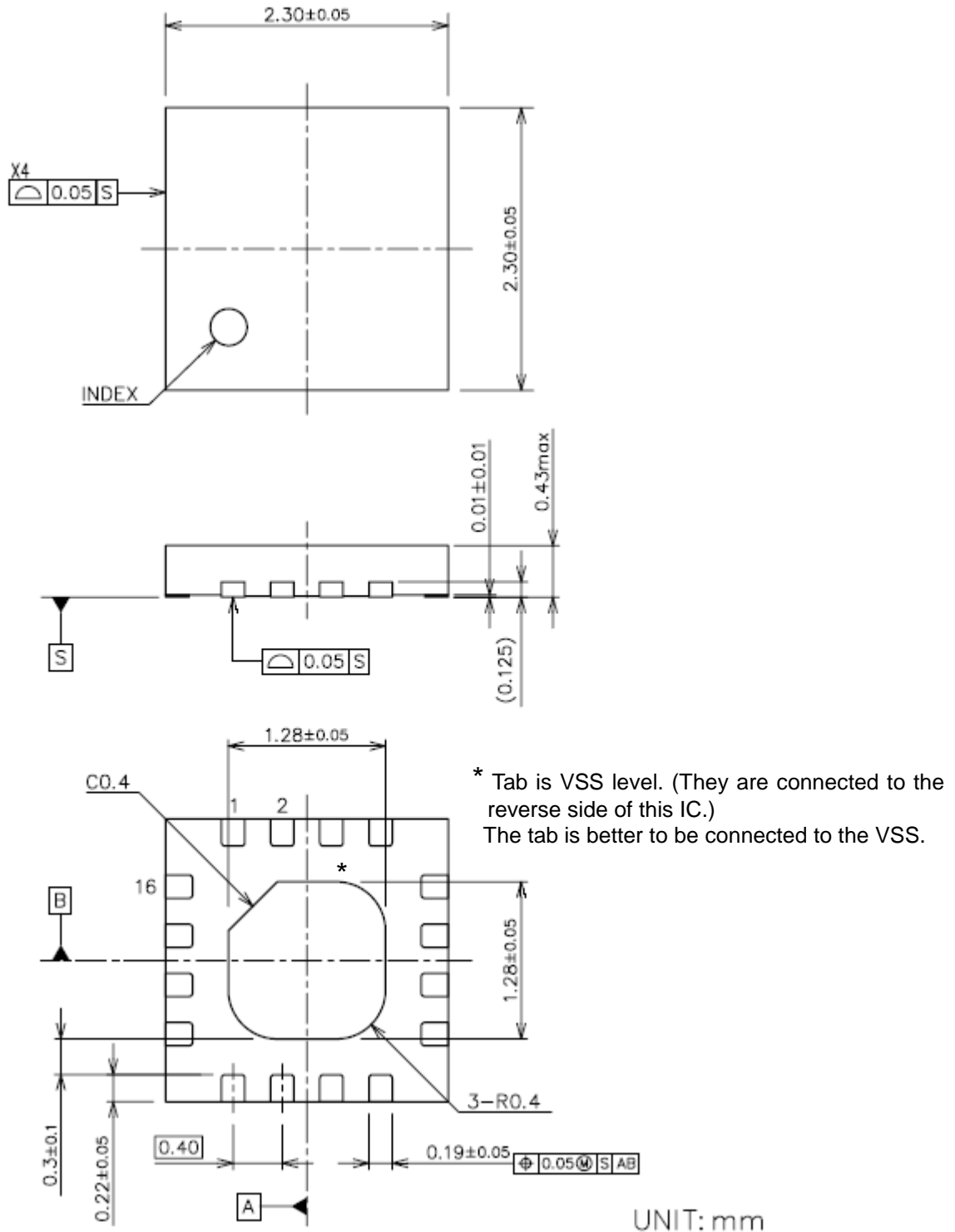

※ The side of the all terminals have no plating treatment.
Therefore, it may not be able to form solder fillet on the side of the terminals.

* R2033K (FFP12) is the discontinued product as of July, 2016.

R2033x

NO.EA-120-160701

R2033T

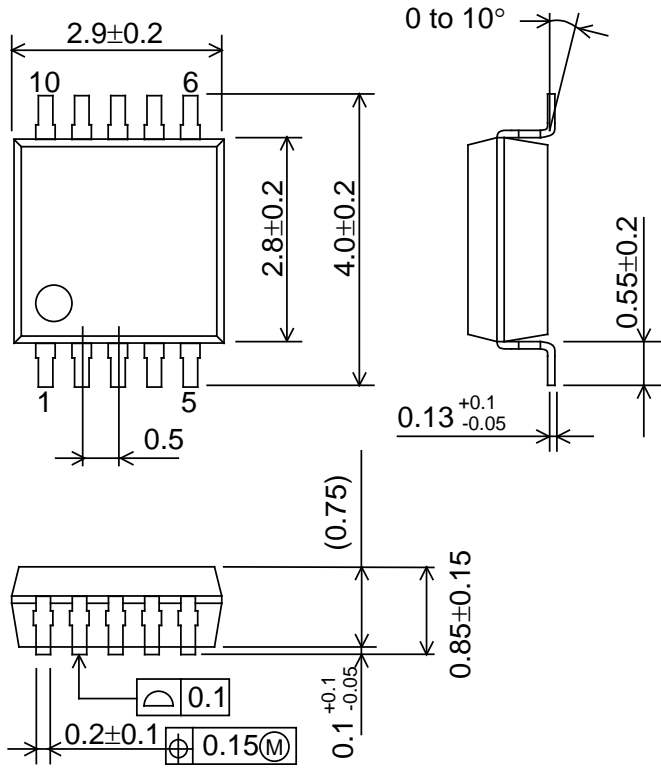

unit: mm

RICOH

R2033x

NO.EA-120-160701

GENERAL DESCRIPTION

- **Interface with CPU**

The R2033x is connected to the CPU by three signal lines CE (Chip Enable), SCLK (Serial Clock), and SIO (Serial Input and Output), through which it reads and writes data from and to the CPU. The CPU can be accessed when the CE pin is held high. Access clock pulses have a maximum frequency of 1 MHz allowing high-speed data transfer to the CPU.

- **Clock and Calendar Function**

The R2033x reads and writes time data from and to the CPU in units ranging from seconds to the last two digits of the calendar year. The calendar year will automatically be identified as a leap year when its last two digits are a multiple of 4. Consequently, leap years up to the year 2099 can automatically be identified as such.

*) The year 2000 is a leap year while the year 2100 is not a leap year.

- **Alarm Function**

The R2033x incorporates the alarm interrupt circuit configured to generate interrupt signals to the CPU at preset times. The alarm interrupt circuit allows two types of alarm settings specified by the Alarm_W registers and the Alarm_D registers. The Alarm_W registers allow week, hour, and minute alarm settings including combinations of multiple day-of-week settings such as "Monday, Wednesday, and Friday" and "Saturday and Sunday". The Alarm_D registers allow hour and minute alarm settings. The Alarm_W outputs from $\overline{\text{INTR}}$ pin, and the Alarm_D outputs also from $\overline{\text{INTR}}$ pin. Each alarm function can be checked from the CPU by using a polling function.

- **High-precision Oscillation Adjustment Function**

The R2033x has built-in oscillation stabilization capacitors (CG and CD), which can be connected to an external crystal oscillator to configure an oscillation circuit. Two kinds of accuracy for this function are alternatives. To correct deviations in the oscillator frequency of the crystal, the oscillation adjustment circuit is configured to allow correction of a time count gain or loss (up to $\pm 1.5\text{ppm}$ or $\pm 0.5\text{ppm}$ at 25°C) from the CPU. The maximum range is approximately $\pm 189\text{ppm}$ (or $\pm 63\text{ppm}$) in increments of approximately 3ppm (or 1ppm). Such oscillation frequency adjustment in each system has the following advantages:

- * Allows timekeeping with much higher precision than conventional RTCs while using a crystal oscillator with a wide range of precision variations.
- * Corrects seasonal frequency deviations through seasonal oscillation adjustment.
- * Allows timekeeping with higher precision particularly with a temperature sensing function out of RTC, through oscillation adjustment in tune with temperature fluctuations.

- **Power-on Reset, Oscillation Halt Sensing Function and Supply Voltage Monitoring Function**

The R2033x incorporates an oscillation halt sensing circuit equipped with internal registers configured to record any past oscillation halt.

Power on reset function reset the control registers when the system is powered on from 0V. At the same time, the fact is memorized to the register as a flag, thereby identifying whether they are powered on from 0V or battery backed-up.

The R2033x also incorporates a supply voltage monitoring circuit equipped with internal registers configured to record any drop in supply voltage below a certain threshold value. Supply voltage monitoring threshold settings

can be selected between 1.6V and 1.3V through internal register settings. The sampling rate is normally 1s. The oscillation halt sensing circuit and the power-on reset flag are configured to confirm the established invalidation of time data in contrast to the supply voltage monitoring circuit intended to confirm the potential invalidation of time data. Further, the supply voltage monitoring circuit can be applied to battery supply voltage monitoring.

- **Periodic Interrupt Function**

The R2033x incorporates the periodic interrupt circuit configured to generate periodic interrupt signals aside from interrupt signals generated by the alarm interrupt circuit for output from the $\overline{\text{INTR}}$ pin. Periodic interrupt signals have five selectable frequency settings of 2 Hz (once per 0.5 seconds), 1 Hz (once per 1 second), 1/60 Hz (once per 1 minute), 1/3600 Hz (once per 1 hour), and monthly (the first day of every month). Further, periodic interrupt signals also have two selectable waveforms, a normal pulse form (with a frequency of 2 Hz or 1 Hz) and special form adapted to interruption from the CPU in the level mode (with second, minute, hour, and month interrupts). The condition of periodic interrupt signals can be monitored with using a polling function.

- **32kHz Clock Output**

The R2033x incorporates a 32-kHz clock circuit configured to generate clock pulses with the oscillation frequency of a 32.768kHz crystal oscillator for output from the 32KOUT pin. The 32KOUT pin is CMOS push-pull output and the output is enabled and disabled when the CLKC pin is held high, and low or open, respectively. The 32-kHz clock output can be disabled by certain register settings but cannot be disabled without manipulation of any two registers with different addresses to prevent disabling in such events as the runaway of the CPU. The 32-kHz clock circuit is enabled at power-on, when the CLKC pin is held high.

R2033x

NO.EA-120-160701

Address Mapping

	Address	Register Name	D a t a							
	A3A2A1A0		D7	D6	D5	D4	D3	D2	D1	D0
0	0 0 0 0	Second Counter	- *2)	S40	S20	S10	S8	S4	S2	S1
1	0 0 0 1	Minute Counter	-	M40	M20	M10	M8	M4	M2	M1
2	0 0 1 0	Hour Counter	-	-	H20 P/ \bar{A}	H10	H8	H4	H2	H1
3	0 0 1 1	Day-of-week Counter	-	-	-	-	-	W4	W2	W1
4	0 1 0 0	Day-of-month Counter	-	-	D20	D10	D8	D4	D2	D1
5	0 1 0 1	Month Counter and Century Bit	19 /20	-	-	MO10	MO8	MO4	MO2	MO1
6	0 1 1 0	Year Counter	Y80	Y40	Y20	Y10	Y8	Y4	Y2	Y1
7	0 1 1 1	Oscillation Adjustment Register *3)	DEV *4)	F6	F5	F4	F3	F2	F1	F0
8	1 0 0 0	Alarm_W (Minute Register)	-	WM40	WM20	WM10	WM8	WM4	WM2	WM1
9	1 0 0 1	Alarm_W (Hour Register)	-	-	WH20 WP/ \bar{A}	WH10	WH8	WH4	WH2	WH1
A	1 0 1 0	Alarm_W (Day-of-week Register)	-	WW6	WW5	WW4	WW3	WW2	WW1	WW0
B	1 0 1 1	Alarm_D (Minute Register)	-	DM40	DM20	DM10	DM8	DM4	DM2	DM1
C	1 1 0 0	Alarm_D (Hour Register)	-	-	DH20 DP/ \bar{A}	DH10	DH8	DH4	DH2	DH1
D	1 1 0 1		-	-	-	-	-	-	-	-
E	1 1 1 0	Control Register 1 *3)	WALE	DALE	12 /24	CLEN2	TEST	CT2	CT1	CT0
F	1 1 1 1	Control Register 2 *3)	VDSL	VDET	XST	PON *5)	CLEN1	CTFG	WAFG	DAFG

Notes:

- * 1) All the data listed above accept both reading and writing.
- * 2) The data marked with "-" is invalid for writing and reset to 0 for reading.
- * 3) When the PON bit is set to 1 in Control Register 2, all the bits are reset to 0 in Oscillation Adjustment Register, Control Register 1 and Control Register 2 excluding the XST bit.
- * 4) When DEV=0, the oscillation adjustment circuit is configured to allow correction of a time count gain or loss up to ± 1.5 ppm.
When DEV=1, the oscillation adjustment circuit is configured to allow correction of a time count gain or loss up to or ± 0.5 ppm.
- * 5) PON is a power-on-reset flag.

Register Settings

• Control Register 1 (ADDRESS Eh)

D7	D6	D5	D4	D3	D2	D1	D0	
WALE	DALE	$\overline{12}/24$	$\overline{CLEN2}$	TEST	CT2	CT1	CT0	(For Writing)
WALE	DALE	$\overline{12}/24$	$\overline{CLEN2}$	TEST	CT2	CT1	CT0	(For Reading)
0	0	0	0	0	0	0	0	Default Settings *)

*) Default settings: Default value means read / written values when the PON bit is set to "1" due to VDD power-on from 0 volts.

(1) WALE, DALE Alarm_W Enable Bit, Alarm_D Enable Bit

WALE,DALE	Description	
0	Disabling the alarm interrupt circuit (under the control of the settings of the Alarm_W registers and the Alarm_D registers).	(Default)
1	Enabling the alarm interrupt circuit (under the control of the settings of the Alarm_W registers and the Alarm_D registers)	

(2) $\overline{12}/24$ $\overline{12}/24$ -hour Mode Selection Bit

$\overline{12}/24$	Description	
0	Selecting the 12-hour mode with a.m. and p.m. indications.	(Default)
1	Selecting the 24-hour mode	

Setting the $\overline{12}/24$ bit to 0 and 1 specifies the 12-hour mode and the 24-hour mode, respectively.

24-hour mode	12-hour mode	24-hour mode	12-hour mode
00	12 (AM12)	12	32 (PM12)
01	01 (AM 1)	13	21 (PM 1)
02	02 (AM 2)	14	22 (PM 2)
03	03 (AM 3)	15	23 (PM 3)
04	04 (AM 4)	16	24 (PM 4)
05	05 (AM 5)	17	25 (PM 5)
06	06 (AM 6)	18	26 (PM 6)
07	07 (AM 7)	19	27 (PM 7)
08	08 (AM 8)	20	28 (PM 8)
09	09 (AM 9)	21	29 (PM 9)
10	10 (AM10)	22	30 (PM10)
11	11 (AM11)	23	31 (PM11)

Setting the $\overline{12}/24$ bit should precede writing time data

(3) $\overline{CLEN2}$ 32kHz Clock Output Bit 2

$\overline{CLEN2}$	Description	
0	Enabling the 32-kHz clock circuit	(Default)
1	Disabling the 32-kHz clock circuit	

Setting the $\overline{CLEN2}$ bit or the $\overline{CLEN1}$ bit (D3 in the control register 2) to 0, and the CLKC pin to high specifies generating clock pulses with the oscillation frequency of the 32.768-kHz crystal oscillator for output from the 32KOUT pin. Conversely, setting both the $\overline{CLEN1}$ and $\overline{CLEN2}$ bit to 1 or CLKC pin to low specifies disabling ("L") such output.

R2033x

NO.EA-120-160701

(4) TEST Test Bit

TEST	Description	(Default)
0	Normal operation mode.	(Default)
1	Test mode.	

The TEST bit is used only for testing in the factory and should normally be set to 0.

(5) CT2,CT1, and CT0 Periodic Interrupt Selection Bits

CT2	CT1	CT0	Description		(Default)
			Wave form mode	Interrupt Cycle and Falling Timing	
0	0	0	-	OFF(H)	(Default)
0	0	1	-	Fixed at "L"	
0	1	0	Pulse Mode *1)	2Hz(Duty50%)	
0	1	1	Pulse Mode *1)	1Hz(Duty50%)	
1	0	0	Level Mode *2)	Once per 1 second (Synchronized with second counter increment)	
1	0	1	Level Mode *2)	Once per 1 minute (at 00 seconds of every minute)	
1	1	0	Level Mode *2)	Once per hour (at 00 minutes and 00 seconds of every hour)	
1	1	1	Level Mode *2)	Once per month (at 00 hours, 00 minutes, and 00 seconds of first day of every month)	

* 1) Pulse Mode: 2-Hz and 1-Hz clock pulses are output in synchronization with the increment of the second counter as illustrated in the timing chart below.

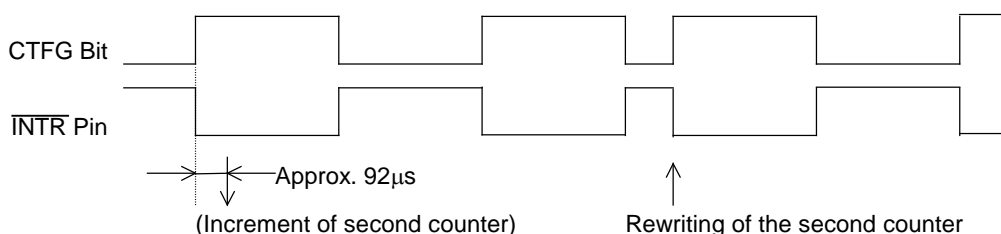

In the pulse mode, the increment of the second counter is delayed by approximately 92 μ s from the falling edge of clock pulses. Consequently, time readings immediately after the falling edge of clock pulses may appear to lag behind the time counts of the real-time clocks by approximately 1 second. Rewriting the second counter will reset the other time counters of less than 1 second, driving the $\overline{\text{INTR}}$ pin low.

* 2) Level Mode: Periodic interrupt signals are output with selectable interrupt cycle settings of 1 second, 1 minute, 1 hour, and 1 month. The increment of the second counter is synchronized with the falling edge of periodic interrupt signals. For example, periodic interrupt signals with an interrupt cycle setting of 1 second are output in synchronization with the increment of the second counter as illustrated in the timing chart below.

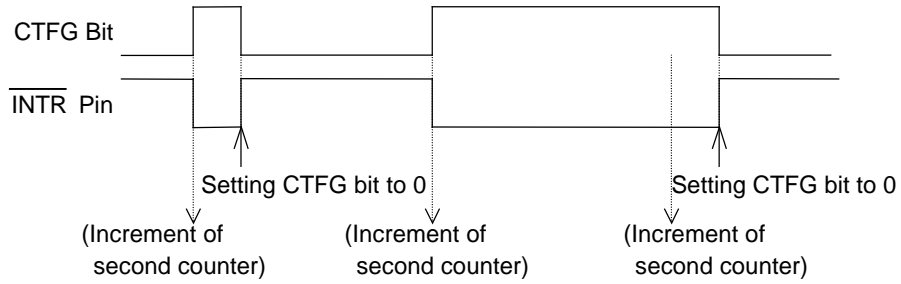

At the level mode, the moment right after writing CT2-CT0, $\overline{\text{INTR}}$ pin becomes "L" in very short moment. In such a case, ignore it or confirm it by CTFG bit.

*1), *2) When the oscillation adjustment circuit is used, the interrupt cycle will fluctuate once per 20sec. or 60sec. as follows:

Pulse Mode: The "L" period of output pulses will increment or decrement by a maximum of ± 3.784 ms. For example, 1-Hz clock pulses will have a duty cycle of $50 \pm 0.3784\%$.

Level Mode: A periodic interrupt cycle of 1 second will increment or decrement by a maximum of ± 3.784 ms.

R2033x

NO.EA-120-160701

• Control Register 2 (Address Fh)

D7	D6	D5	D4	D3	D2	D1	D0	
VDSL	VDET	\overline{XST}	PON	$\overline{CLEN1}$	CTFG	WAFG	DAFG	(For Writing)
VDSL	VDET	\overline{XST}	PON	$\overline{CLEN1}$	CTFG	WAFG	DAFG	(For Reading)
0	0	Indefinite	1	0	0	0	0	Default Settings *)

*) Default settings: Default value means read / written values when the PON bit is set to "1" due to VDD power-on from 0 volts.

(1) VDSL VDD Supply Voltage Monitoring Threshold Selection Bit

VDSL	Description	
0	Selecting the VDD supply voltage monitoring threshold setting of 2.1v.	(Default)
1	Selecting the VDD supply voltage monitoring threshold setting of 1.35v.	

The VDSL bit is intended to select the VDD supply voltage monitoring threshold settings.

(2) VDET Supply Voltage Monitoring Result Indication Bit

VDET	Description	
0	Indicating supply voltage above the supply voltage monitoring threshold settings.	(Default)
1	Indicating supply voltage below the supply voltage monitoring threshold settings.	

Once the VDET bit is set to 1, the supply voltage monitoring circuit will be disabled while the VDET bit will hold the setting of 1. The VDET bit accepts only the writing of 0, which restarts the supply voltage monitoring circuit. Conversely, setting the VDET bit to 1 causes no event.

(3) \overline{XST} Oscillation Halt Sensing Monitor Bit

\overline{XST}	Description
0	Sensing a halt of oscillation
1	Sensing a normal condition of oscillation

The \overline{XST} accepts the reading and writing of 0 and 1. The \overline{XST} bit will be set to 0 when the oscillation halt sensing. The \overline{XST} bit will hold 0 even after the restart of oscillation.

(4) PON Power-on-reset Flag Bit

PON	Description	
0	Normal condition	
1	Detecting VDD power-on -reset	(Default)

The PON bit is for sensing power-on reset condition.

* The PON bit will be set to 1 when VDD power-on from 0 volts. The PON bit will hold the setting of 1 even after power-on.

* When the PON bit is set to 1, all bits will be reset to 0, in the Oscillation Adjustment Register, Control Register 1, and Control Register 2, except \overline{XST} and PON. As a result, \overline{INTR} pin stops outputting.

* The PON bit accepts only the writing of 0. Conversely, setting the PON bit to 1 causes no event.

(5) $\overline{\text{CLEN1}}$ 32kHz Clock Output Bit 1

$\overline{\text{CLEN1}}$	Description
0	Enabling the 32-kHz clock circuit
1	Disabling the 32-kHz clock circuit

(Default)

Setting the $\overline{\text{CLEN1}}$ bit or the $\overline{\text{CLEN2}}$ bit (D4 in the control register 1) to 0, and the CLKC pin to high specifies generating clock pulses with the oscillation frequency of the 32.768-kHz crystal oscillator for output from the 32KOUT pin. Conversely, setting both the $\overline{\text{CLEN1}}$ and $\overline{\text{CLEN2}}$ bit to 1 or CLKC pin to low specifies disabling ("L") such output.

(6) CTFG Periodic Interrupt Flag Bit

CTFG	Description
0	Periodic interrupt output = "H"
1	Periodic interrupt output = "L"

(Default)

The CTFG bit is set to 1 when the periodic interrupt signals are output from the $\overline{\text{INTR}}$ pin ("L"). The CTFG bit accepts only the writing of 0 in the level mode, which disables ("H") the $\overline{\text{INTR}}$ pin until it is enabled ("L") again in the next interrupt cycle. Conversely, setting the CTFG bit to 1 causes no event.

(7) WAFG,DAFG Alarm_W Flag Bit and Alarm_D Flag Bit

WAFG,DAFG	Description
0	Indicating a mismatch between current time and preset alarm time
1	Indicating a match between current time and preset alarm time

(Default)

The WAFG and DAFG bits are valid only when the WALE and DALE have the setting of 1, which is caused approximately 31 μ s after any match between current time and preset alarm time specified by the Alarm_W registers and the Alarm_D registers. The WAFG (DAFG) bit accepts only the writing of 0. $\overline{\text{INTR}}$ pin outputs off ("H") when this bit is set to 0. And $\overline{\text{INTR}}$ pin outputs "L" again at the next preset alarm time. Conversely, setting the WAFG and DAFG bits to 1 causes no event. The WAFG and DAFG bits will have the reading of 0 when the alarm interrupt circuit is disabled with the WALE and DALE bits set to 0. The settings of the WAFG and DAFG bits are synchronized with the output of the $\overline{\text{INTR}}$ pin as shown in the timing chart below.

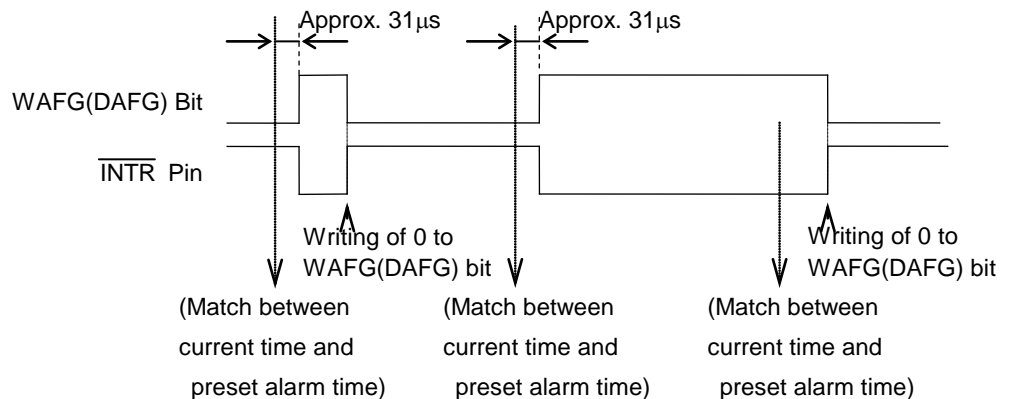

R2033x

NO.EA-120-160701

• Time Counter (Address 0-2h)

Second Counter (Address 0h)

D7	D6	D5	D4	D3	D2	D1	D0	
-	S40	S20	S10	S8	S4	S2	S1	(For Writing)
0	S40	S20	S10	S8	S4	S2	S1	(For Reading)
0	Indefinite	Indefinite	Indefinite	Indefinite	Indefinite	Indefinite	Indefinite	Default Settings *)

Minute Counter (Address 1h)

D7	D6	D5	D4	D3	D2	D1	D0	
-	M40	M20	M10	M8	M4	M2	M1	(For Writing)
0	M40	M20	M10	M8	M4	M2	M1	(For Reading)
0	Indefinite	Indefinite	Indefinite	Indefinite	Indefinite	Indefinite	Indefinite	Default Settings *)

Hour Counter (Address 2h)

D7	D6	D5	D4	D3	D2	D1	D0	
-	-	P/ \overline{A} or H20	H10	H8	H4	H2	H1	(For Writing)
0	0	P/ \overline{A} or H20	H10	H8	H4	H2	H1	(For Reading)
0	0	Indefinite	Indefinite	Indefinite	Indefinite	Indefinite	Indefinite	Default Settings *)

*) Default settings: Default value means read / written values when the PON bit is set to "1" due to VDD power-on from 0 volts.

* Time digit display (BCD format) as follows:

The second digits range from 00 to 59 and are carried to the minute digit in transition from 59 to 00.

The minute digits range from 00 to 59 and are carried to the hour digits in transition from 59 to 00.

The hour digits range as shown in "P13 • Control Register 1 (ADDRESS Eh) (2) $\overline{12}$ /24: $\overline{12}$ /24-hour Mode Selection Bit" and are carried to the day-of-month and day-of-week digits in transition from PM11 to AM12 or from 23 to 00.

* Any writing to the second counter resets divider units of less than 1 second.

* Any carry from lower digits with the writing of non-existent time may cause the time counters to malfunction. Therefore, such incorrect writing should be replaced with the writing of existent time data.

• **Day-of-week Counter (Address 3h)**

D7	D6	D5	D4	D3	D2	D1	D0	
-	-	-	-	-	W4	W2	W1	(For Writing)
0	0	0	0	0	W4	W2	W1	(For Reading)
0	0	0	0	0	Indefinite	Indefinite	Indefinite	Default Settings *)

*) Default settings: Default value means read / written values when the PON bit is set to "1" due to VDD power-on from 0 volts.

* The day-of-week counter is incremented by 1 when the day-of-week digits are carried to the day-of-month digits.

* Day-of-week display (incremented in septimal notation):

(W4, W2, W1) = (0, 0, 0) → (0, 0, 1) → ... → (1, 1, 0) → (0, 0, 0)

* Correspondences between days of the week and the day-of-week digits are user-definable (e.g. Sunday = 0, 0, 0)

* The writing of (1, 1, 1) to (W4, W2, W1) is prohibited except when days of the week are unused.

• **Calendar Counter (Address 4-6h)**

Day-of-month Counter (Address 4h)

D7	D6	D5	D4	D3	D2	D1	D0	
-	-	D20	D10	D8	D4	D2	D1	(For Writing)
0	0	D20	D10	D8	D4	D2	D1	(For Reading)
0	0	Indefinite	Indefinite	Indefinite	Indefinite	Indefinite	Indefinite	Default Settings *)

Month Counter + Century Bit (Address 5h)

D7	D6	D5	D4	D3	D2	D1	D0	
$\overline{19}/20$	-	-	MO10	MO8	MO4	MO2	MO1	(For Writing)
$\overline{19}/20$	0	0	MO10	MO8	MO4	MO2	MO1	(For Reading)
Indefinite	0	0	Indefinite	Indefinite	Indefinite	Indefinite	Indefinite	Default Settings *)

Year Counter (Address 6h)

D7	D6	D5	D4	D3	D2	D1	D0	
Y80	Y40	Y20	Y10	Y8	Y4	Y2	Y1	(For Writing)
Y80	Y40	Y20	Y10	Y8	Y4	Y2	Y1	(For Reading)
Indefinite	Indefinite	Indefinite	Indefinite	Indefinite	Indefinite	Indefinite	Indefinite	Default Settings *)

*) Default settings: Default value means read / written values when the PON bit is set to "1" due to VDD power-on from 0 volts.

* The calendar counters are configured to display the calendar digits in BCD format by using the automatic calendar function as follows:

The day-of-month digits (D20 to D1) range from 1 to 31 for January, March, May, July, August, October, and December; from 1 to 30 for April, June, September, and November; from 1 to 29 for February in leap years; from 1 to 28 for February in ordinary years. The day-of-month digits are carried to the month digits in reversion from the last day of the month to 1. The month digits (MO10 to MO1) range from 1 to 12 and are carried to the year digits in reversion from 12 to 1.

The year digits (Y80 to Y1) range from 00 to 99 (00, 04, 08, ..., 92, and 96 in leap years) and are carried

R2033x

NO.EA-120-160701

to the $\overline{19}$ /20 digits in reversion from 99 to 00.

The $\overline{19}$ /20 digits cycle between 0 and 1 in reversion from 99 to 00 in the year digits.

- * Any carry from lower digits with the writing of non-existent calendar data may cause the calendar counters to malfunction. Therefore, such incorrect writing should be replaced with the writing of existent calendar data.

● Oscillation Adjustment Register (Address 7h)

D7	D6	D5	D4	D3	D2	D1	D0	
DEV	F6	F5	F4	F3	F2	F1	F0	(For Writing)
DEV	F6	F5	F4	F3	F2	F1	F0	(For Reading)
0	0	0	0	0	0	0	0	Default Settings *)

- *) Default settings: Default value means read / written values when the PON bit is set to "1" due to VDD power-on from 0 volts.

DEV bit

When DEV is set to 0, the Oscillation Adjustment Circuit operates 00, 20, 40 seconds.

When DEV is set to 1, the Oscillation Adjustment Circuit operates 00 seconds.

F6 to F0 bits

The Oscillation Adjustment Circuit is configured to change time counts of 1 second on the basis of the settings of the Oscillation Adjustment Register at the timing set by DEV.

- * The Oscillation Adjustment Circuit will not operate with the same timing (00, 20, or 40 seconds) as the timing of writing to the Oscillation Adjustment Register.
- * The F6 bit setting of 0 causes an increment of time counts by $((F5, F4, F3, F2, F1, F0) - 1) \times 2$.
The F6 bit setting of 1 causes a decrement of time counts by $((\overline{F5}, \overline{F4}, \overline{F3}, \overline{F2}, \overline{F1}, \overline{F0}) + 1) \times 2$.
The settings of "*", 0, 0, 0, 0, 0, "*" ("*" representing either "0" or "1") in the F6, F5, F4, F3, F2, F1, and F0 bits cause neither an increment nor decrement of time counts.

Example:

If (DEV, F6, F5, F4, F3, F2, F1, F0) is set to (0, 0, 0, 0, 0, 1, 1, 1), when the second digits read 00, 20, or

40, an increment of the current time counts of $32768 + (7 - 1) \times 2$ to 32780 (a current time count loss).

If (DEV, F6, F5, F4, F3, F2, F1, F0) is set to (0, 0, 0, 0, 0, 0, 0, 1), when the second digits read 00, 20, 40, neither an increment nor a decrement of the current time counts of 32768.

If (DEV, F6, F5, F4, F3, F2, F1, F0) is set to (1, 1, 1, 1, 1, 1, 1, 0), when the second digits read 00, a decrement of the current time counts of $32768 + (-2) \times 2$ to 32764 (a current time count gain).

An increase of two clock pulses once per 20 seconds causes a time count loss of approximately 3 ppm ($2 / (32768 \times 20) = 3.051$ ppm). Conversely, a decrease of two clock pulses once per 20 seconds causes a time count gain of 3 ppm. Consequently, when DEV is set to "0", deviations in time counts can be corrected with a precision of ± 1.5 ppm. In the same way, when DEV is set to "1", deviations in time counts can be corrected with a precision of ± 0.5 ppm. Note that the oscillation adjustment circuit is configured to correct deviations in time counts and not the oscillation frequency of the 32.768-kHz clock pulses. For further details, see "P33 Configuration of Oscillation Circuit and Correction of Time Count Deviations

- Oscillation Adjustment Circuit".

• Alarm_W Registers (Address 8-Ah)

Alarm_W Minute Register (Address 8h)

D7	D6	D5	D4	D3	D2	D1	D0	
-	WM40	WM20	WM10	WM8	WM4	WM2	WM1	(For Writing)
0	WM40	WM20	WM10	WM8	WM4	WM2	WM1	(For Reading)
0	Indefinite	Indefinite	Indefinite	Indefinite	Indefinite	Indefinite	Indefinite	Default Settings *)

Alarm_W Hour Register (Address 9h)

D7	D6	D5	D4	D3	D2	D1	D0	
-	-	WH20 WP/ \bar{A}	WH10	WH8	WH4	WH2	WH1	(For Writing)
0	0	WH20 WP/ \bar{A}	WH10	WH8	WH4	WH2	WH1	(For Reading)
0	0	Indefinite	Indefinite	Indefinite	Indefinite	Indefinite	Indefinite	Default Settings *)

Alarm_W Day-of-week Register (Address Ah)

D7	D6	D5	D4	D3	D2	D1	D0	
-	WW6	WW5	WW4	WW3	WW2	WW1	WW0	(For Writing)
0	WW6	WW5	WW4	WW3	WW2	WW1	WW0	(For Reading)
0	Indefinite	Indefinite	Indefinite	Indefinite	Indefinite	Indefinite	Indefinite	Default Settings *)

*) Default settings: Default value means read / written values when the PON bit is set to "1" due to VDD power-on from 0 volts.

* The D5 bit of the Alarm_W Hour Register represents WP/ \bar{A} when the 12-hour mode is selected (0 for a.m. and 1 for p.m.) and WH20 when the 24-hour mode is selected (tens in the hour digits).

* The Alarm_W Registers should not have any non-existent alarm time settings.

(Note that any mismatch between current time and preset alarm time specified by the Alarm_W registers may disable the alarm interrupt circuit.)

* When the 12-hour mode is selected, the hour digits read 12 and 32 for 0 a.m. and 0 p.m., respectively. (See "P13 •Control Register 1 (ADDRESS Eh) (2) $\overline{12}$ /24: $\overline{12}$ /24-hour Mode Selection Bit")

* WW0 to WW6 correspond to W4, W2, and W1 of the day-of-week counter with settings ranging from (0, 0, 0) to (1, 1, 0).

* WW0 to WW6 with respective settings of 0 disable the outputs of the Alarm_W Registers.

R2033x

NO.EA-120-160701

Example of Alarm Time Setting

Alarm Preset alarm time	Day-of-week							12-hour mode				24-hour mode				
	Sun.	Mon.	Tue.	Wed.	Th.	Fri.	Sat.	10 hr.	1 hr.	10 min.	1 min.	10 hr.	1 hr.	10 min.	1 min.	
	WW0	WW1	WW2	WW3	WW4	WW5	WW6									
00:00 a.m. on all days	1	1	1	1	1	1	1	1	2	0	0	0	0	0	0	0
01:30 a.m. on all days	1	1	1	1	1	1	1	0	1	3	0	0	1	3	0	0
11:59 a.m. on all days	1	1	1	1	1	1	1	1	1	5	9	1	1	5	9	
00:00 p.m. on Mon. to Fri.	0	1	1	1	1	1	0	3	2	0	0	1	2	0	0	
01:30 p.m. on Sun.	1	0	0	0	0	0	0	2	1	3	0	1	3	3	0	
11:59 p.m. on Mon., Wed., and Fri.	0	1	0	1	0	1	0	3	1	5	9	2	3	5	9	

Note that the correspondence between WW0 to WW6 and the days of the week shown in the above table is only an example and not mandatory.

• Alarm_D Register (Address B-Ch)

Alarm_D Minute Register (Address Bh)

D7	D6	D5	D4	D3	D2	D1	D0	
-	DM40	DM20	DM10	DM8	DM4	DM2	DM1	(For Writing)
0	DM40	DM20	DM10	DM8	DM4	DM2	DM1	(For Reading)
0	Indefinite	Indefinite	Indefinite	Indefinite	Indefinite	Indefinite	Indefinite	Default Settings *)

Alarm_D Hour Register (Address Ch)

D7	D6	D5	D4	D3	D2	D1	D0	
-	-	DH20 DP/ \bar{A}	DH10	DH8	DH4	DH2	DH1	(For Writing)
0	0	DH20 DP/ \bar{A}	DH10	DH8	DH4	DH2	DH1	(For Reading)
0	0	Indefinite	Indefinite	Indefinite	Indefinite	Indefinite	Indefinite	Default Settings *)

*) Default settings: Default value means read / written values when the PON bit is set to "1" due to VDD power-on from 0 volts.

* The D5 bit represents DP/ \bar{A} when the 12-hour mode is selected (0 for a.m. and 1 for p.m.) and DH20 when the 24-hour mode is selected (tens in the hour digits).

* The Alarm_D registers should not have any non-existent alarm time settings.

(Note that any mismatch between current time and preset alarm time specified by the Alarm_D registers may disable the alarm interrupt circuit.)

* When the 12-hour mode is selected, the hour digits read 12 and 32 for 0a.m. and 0p.m., respectively.

(See "P13 •Control Register 1 (ADDRESS Eh) (2) 12 /24: 12 /24-hour Mode Selection Bit")

Interfacing with the CPU

• DATA TRANSFER FORMATS

(1) Timing Between CE Pin Transition and Data Input / Output

The R2033x adopts a 3-wire serial interface by which they use the CE (Chip Enable), SCLK (Serial Clock), and SIO (Serial Input/Output) pins to receive and send data to and from the CPU. The 3-wire serial interface provides two types of input/output timings with which the SIO pin output and input are synchronized with the rising or falling edges of the SCLK pin input, respectively, and vice versa. The R2033x is configured to select either one of two different input/output timings depending on the level of the SCLK pin in the low to high transition of the CE pin. Namely, when the SCLK pin is held low in the low to high transition of the CE pin, the models will select the timing with which the SIO pin output is synchronized with the rising edge of the SCLK pin input, and the input is synchronized with the falling edge of the SCLK pin input, as illustrated in the timing chart below.

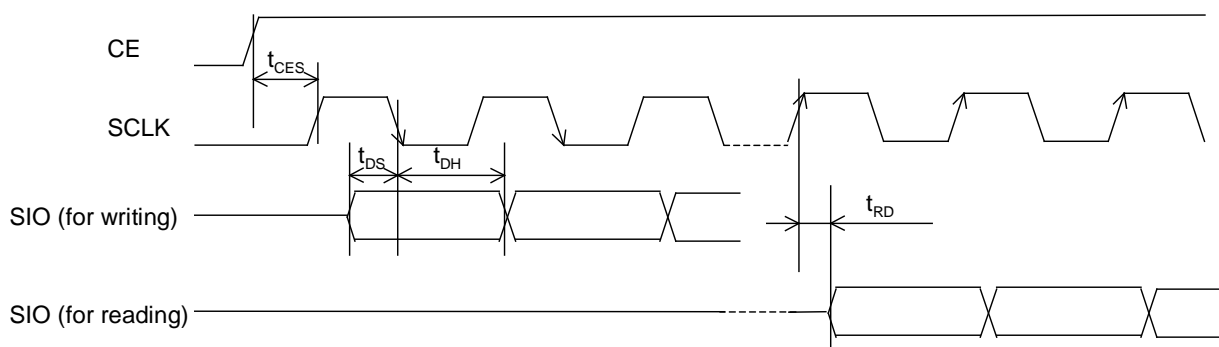

Conversely, when the SCLK pin is held high in the low to high transition of the CE pin, the models will select the timing with which the SIO pin output is synchronized with the falling edge of the SCLK pin input, and the input is synchronized with the rising edge of the SCLK pin input, as illustrated in the timing chart below.

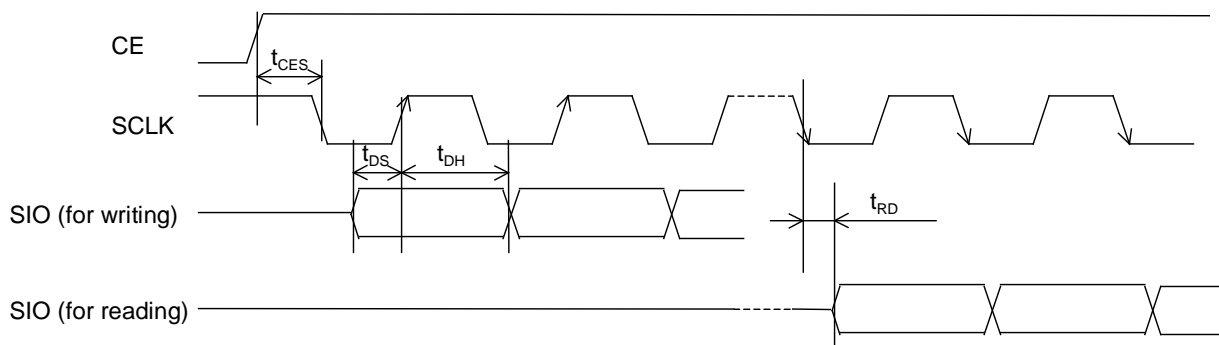

R2033x

NO.EA-120-160701

(2) Data Transfer Formats

Data transfer is commenced in the low to high transition of the CE pin input and completed in its high to low transition. Data transfer is conducted serially in multiple units of 1 byte (8 bits). The former 4 bits are used to specify in the Address Pointer a head address with which data transfer is to be commenced from the host. The latter 4 bits are used to select either reading data transfer or writing data transfer, and to set the Transfer Format Register to specify an appropriate data transfer format. All data transfer formats are designed to transfer the most significant bit (MSB) first.

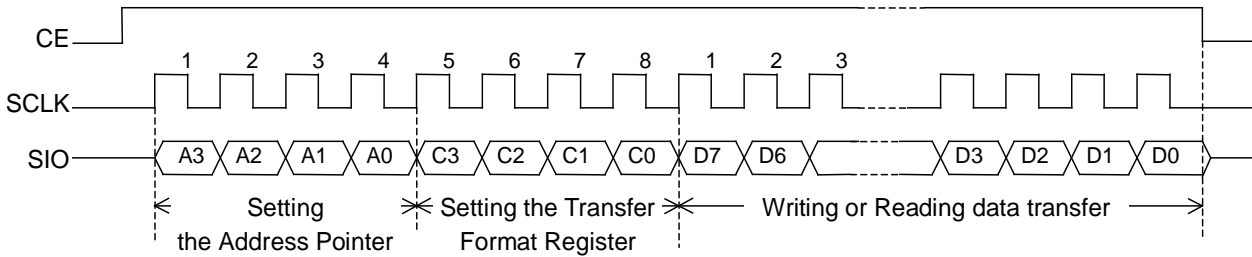

Two types of data transfer formats are available for reading data transfer and writing data transfer each.

• Writing Data Transfer Formats

(1) 1-byte Writing Data Transfer Format

The first type of writing data transfer format is designed to transfer 1-byte data at a time and can be selected by specifying in the address pointer a head address with which writing data transfer is to be commenced and then writing the setting of 8h to the transfer format register. This 1-byte writing data transfer can be completed by driving the CE pin low or continued by specifying a new head address in the address pointer and setting the data transfer format.

Example of 1-byte Writing Data Transfer (For Writing Data to Addresses Fh and 7h)

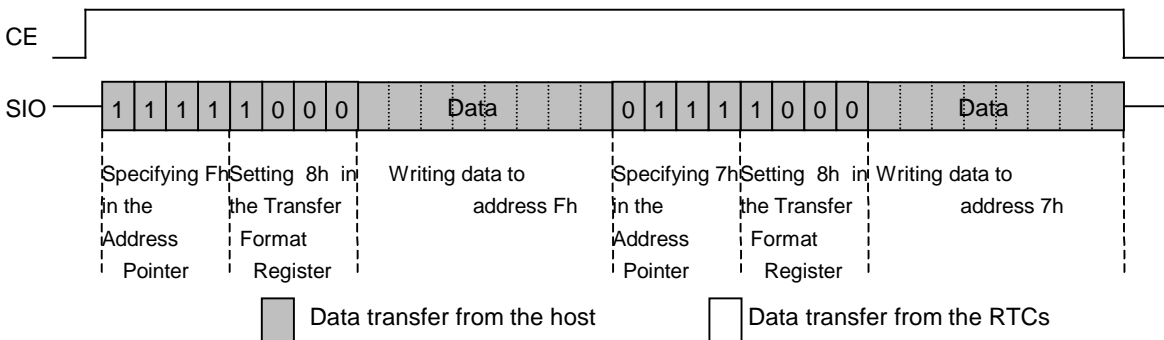

(2) Burst Writing Data Transfer Format

The second type of writing data transfer format is designed to transfer a sequence of data serially and can be selected by specifying in the address pointer a head address with which writing data transfer is to be commenced and then writing the setting of 0h to the transfer format register. The address pointer is incremented for each transfer of 1-byte data and cycled from Fh to 0h. This burst writing data transfer can be completed by driving the CE pin low.

Example of Burst Writing Data Transfer (For Writing Data to Addresses Eh, Fh, and 0h)

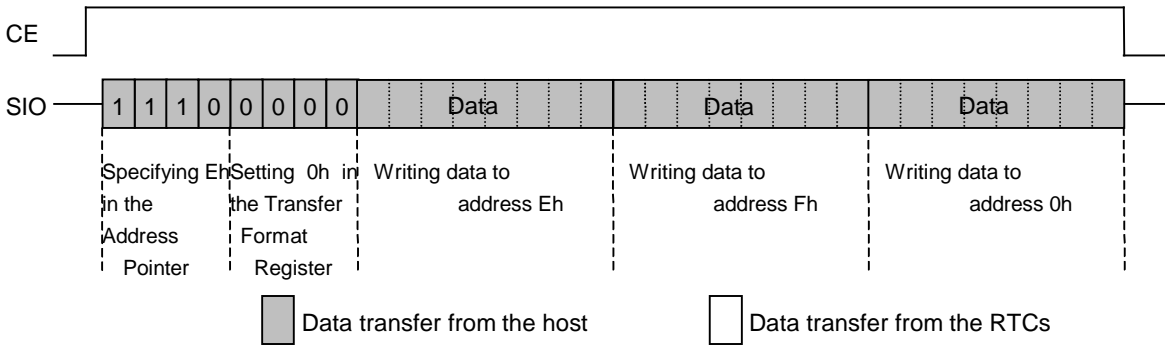

• Reading Data Transfer Formats

(1) 1-byte Reading Data Transfer Format

The first type of reading data transfer format is designed to transfer 1-byte data at a time and can be selected by specifying in the Address Pointer a head address with which reading data transfer is to be commenced and then the setting of writing Ch to the Transfer Format Register. This 1-byte reading data transfer can be completed by driving the CE pin low or continued by specifying a new head address in the Address Pointer and selecting this type of reading data Transfer Format.

Example of 1-byte Reading Data Transfer (For Reading Data from Addresses Eh and 2h)

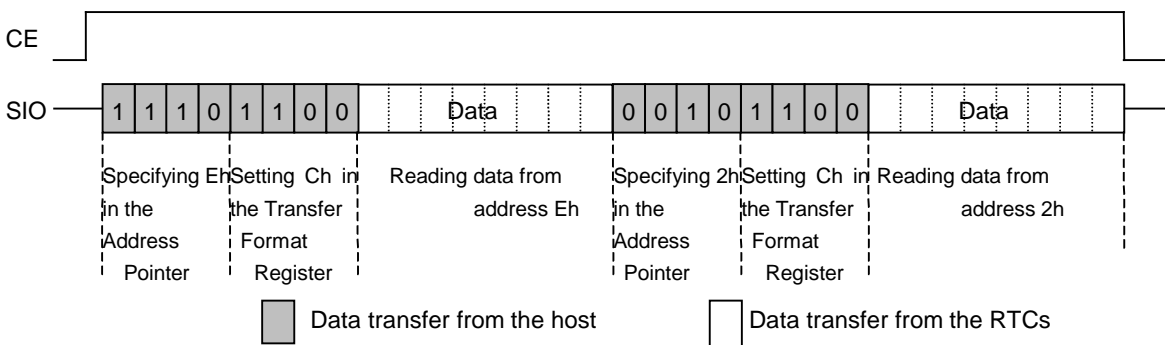

R2033x

NO.EA-120-160701

(2) Burst Reading Data Transfer Format

The second type of reading data transfer format is designed to transfer a sequence of data serially and can be selected by specifying in the address pointer a head address with which reading data transfer is to be commenced and then writing the setting of 4h to the transfer format register. The address pointer is incremented for each transfer of 1-byte data and cycled from Fh to 0h. This burst reading data transfer can be completed by driving the CE pin low.

Example of Burst Reading Data Transfer (For Reading Data from Addresses Fh, 0h, and 1h)

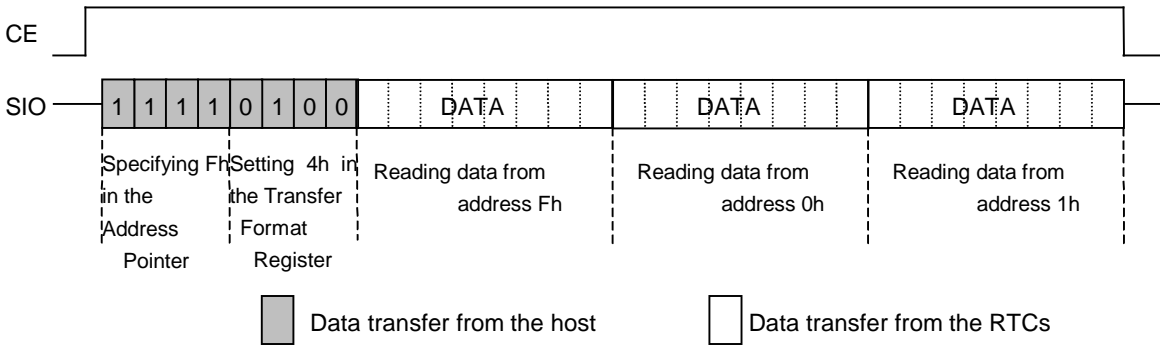

(3) Combination of 1-byte Reading and writing Data Transfer Formats

The 1-byte reading and writing data transfer formats can be combined together and further followed by any other data transfer format.

Example of Reading Modify Writing Data Transfer

(For Reading and Writing Data from and to Address Fh)

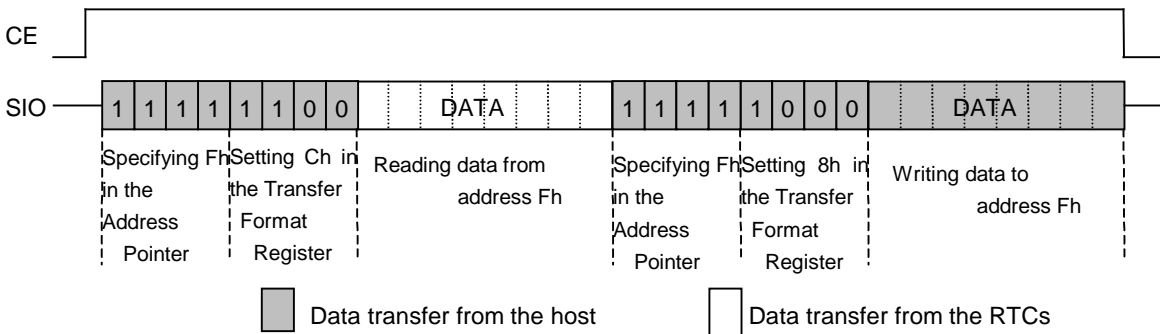

The reading and writing data transfer formats correspond to the settings in the transfer format register as shown in the table below.

	1 Byte	Burst
Writing data transfer	8h (1,0,0,0)	0h (0,0,0,0)
Reading data transfer	Ch (1,1,0,0)	4h (0,1,0,0)

• **Considerations in Reading and Writing Time Data under special condition**

Any carry to the second digits in the process of reading or writing time data may cause reading or writing erroneous time data. For example, suppose a carry out of 13:59:59 into 14:00:00 occurs in the process of reading time data in the middle of shifting from the minute digits to the hour digits. At this moment, the second digits, the minute digits, and the hour digits read 59 seconds, 59 minutes, and 14 hours, respectively (indicating 14:59:59) to cause the reading of time data deviating from actual time virtually 1 hour. A similar error also occurs in writing time data. To prevent such errors in reading and writing time data, the R2033x has the function of temporarily locking any carry to the second digits during the high interval of the CE pin and unlocking such a carry in its high to low transition. Note that a carry to the second digits can be locked for only 1 second, during which time the CE pin should be driven low.

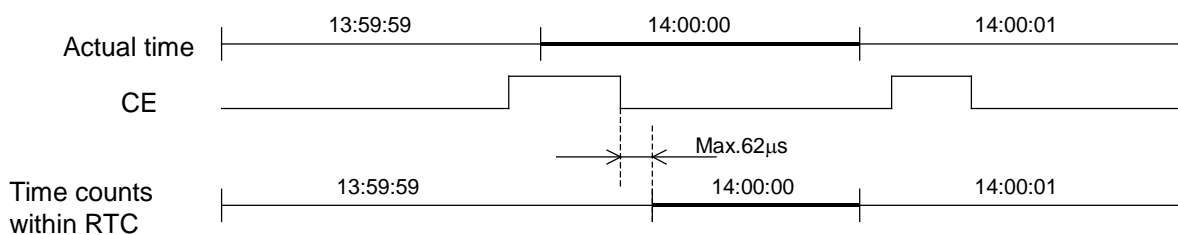

The effective use of this function requires the following considerations in reading and writing time data:

- (1) Hold the CE pin high in each session of reading or writing time data.
- (2) Ensure that the high interval of the CE pin lasts within 1 second. Should there be any possibility of the host going down in the process of reading or writing time data, make arrangements in the peripheral circuitry as to drive the CE pin low or open at the moment that the host actually goes down.
- (3) Leave a time span of 31µs or more from the low to high transition of the CE pin to the start of access to addresses 0h to 6h in order that any ongoing carry of the time digits may be completed within this time span. For further details, see the next page.
- (4) Leave a time span of 62µs or more from the high to low transition of the CE pin to its low to high transition in order that any ongoing carry of the time digits during the high interval of the CE pin may be adjusted within this time span.

The considerations listed in (1), (3), and (4) above are not required when the process of reading or writing time data is obviously free from any carry of the time digits.

(e.g. reading or writing time data in synchronization with the periodic interrupt function in the level mode or the alarm interrupt function).

Bad examples of reading and writing time data are illustrated on the next page.

R2033x

NO.EA-120-160701

Bad Example (1)

Where the CE pin is once driven low in the process of reading time data

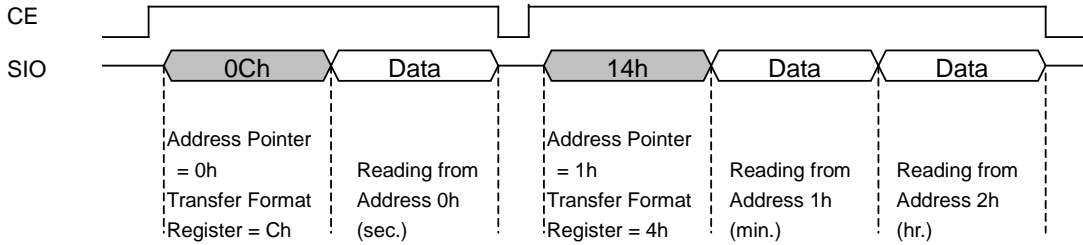

Bad Example (2)

The high interval of the CE pin is more than 1sec.

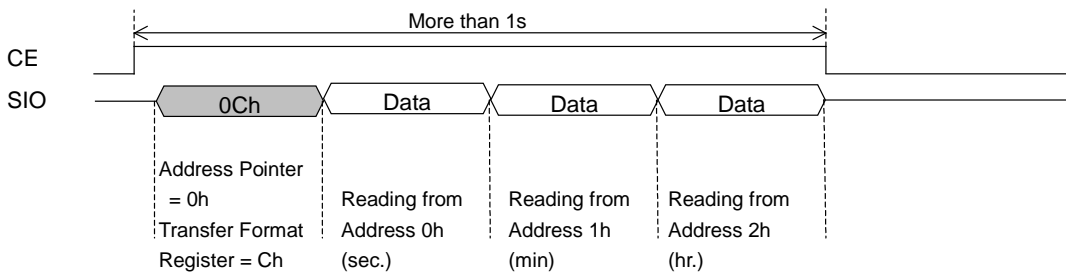

Bad Example (3)

Where a time span of less than 31µs is left until the start of the process of writing or reading time data

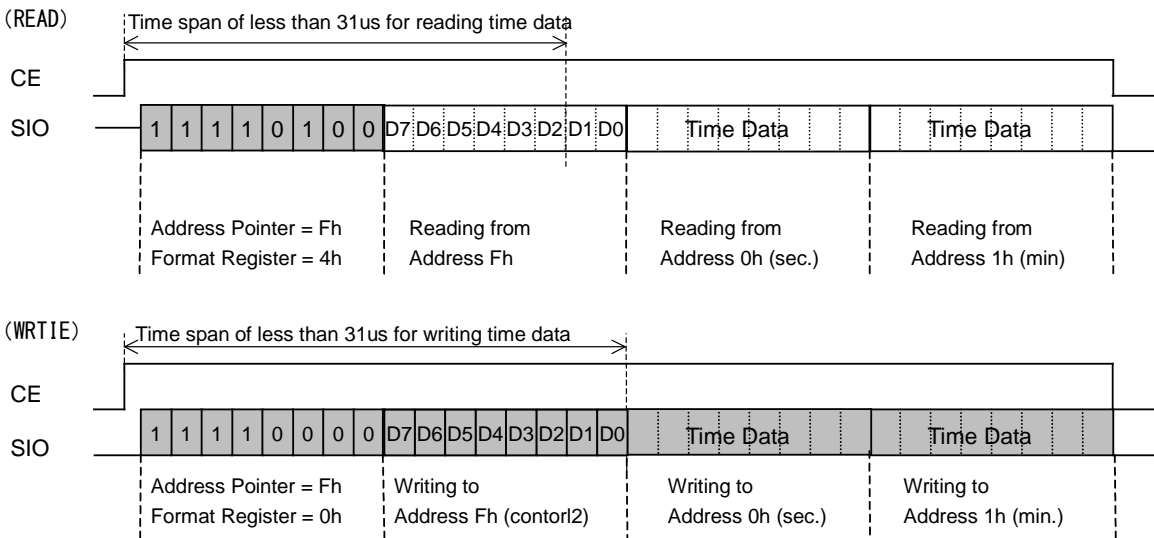

Bad Example (4)

(Where a time span of less than 61µs is left between the adjacent processes of reading time data)

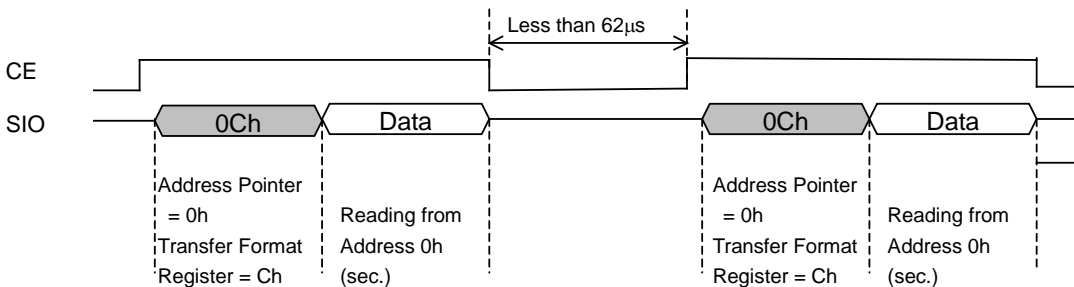

Configuration of Oscillation Circuit and Correction of Time Count Deviations

• Configuration of Oscillation Circuit

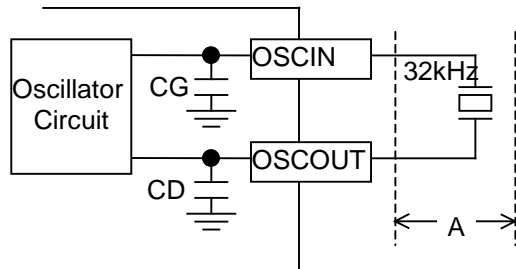

Typical externally-equipped element

X'tal : 32.768kHz

(R1=30kΩ typ)

(CL=6pF to 8pF)

Standard values of internal elements

CG,CD 10pF typ

The oscillation circuit is driven at a constant voltage of approximately 1.1 volts relative to the level of the VSS pin input. As such, it is configured to generate an oscillating waveform with a peak-to-peak voltage on the order of 1.1 volts on the positive side of the VSS pin input.

< Considerations in Handling quartz crystal unit >

Generally, quartz crystal units have basic characteristics including an equivalent series resistance (R1) indicating the ease of their oscillation and a load capacitance (CL) indicating the degree of their center frequency. Particularly, quartz crystal units intended for use in the R2033x are recommended to have a typical R1 value of 50kΩ and a typical CL value of 6 to 9pF. To confirm these recommended values, contact the manufacturers of quartz crystal units intended for use in these particular models.

< Considerations in Installing Components around the Oscillation Circuit >

- 1) Install the quartz crystal unit in the closest possible vicinity to the real-time clock ICs.
- 2) Avoid laying any signal lines or power lines in the vicinity of the oscillation circuit (particularly in the area marked "A" in the above figure).
- 3) Apply the highest possible insulation resistance between the OSCIN and OSCOUT pins and the printed circuit board.
- 4) Avoid using any long parallel lines to wire the OSCIN and OSCOUT pins.
- 5) Take extreme care not to cause condensation, which leads to various problems such as oscillation halt.

< Other Relevant Considerations >

- 1) We cannot recommend connecting the external input of 32.768-kHz clock pulses to the OSCIN pin.
- 2) To maintain stable characteristics of the quartz crystal unit, avoid driving any other IC through 32.768-kHz clock pulses output from the OSCOUT pin.

R2033x

NO.EA-120-160701

• Measurement of Oscillation Frequency

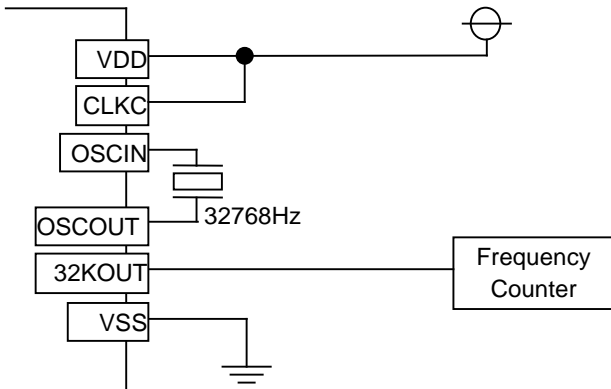

- * 1) The R2033x is configured to generate 32.768-kHz clock pulses for output from the 32KOUT pin.
- * 2) A frequency counter with 6 (more preferably 7) or more digits on the order of 1ppm is recommended for use in the measurement of the oscillation frequency of the oscillation circuit.

• Adjustment of Oscillation frequency

The oscillation frequency of the oscillation circuit can be adjusted by varying procedures depending on the usage of Model R2033x in the system into which they are to be built and on the allowable degree of time count errors. The flow chart below serves as a guide to selecting an optimum oscillation frequency adjustment procedure for the relevant system.

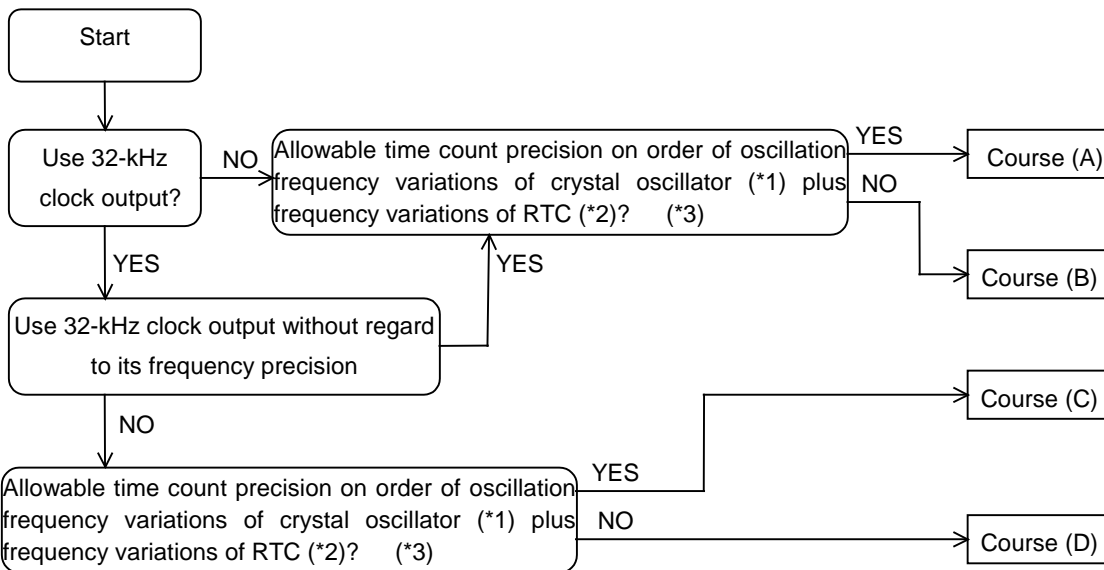

* 1) Generally, quartz crystal units for commercial use are classified in terms of their center frequency depending on their load capacitance (CL) and further divided into ranks on the order of ± 10 , ± 20 , and ± 50 ppm depending on the degree of their oscillation frequency variations.

* 2) Basically, Model R2033x is configured to cause frequency variations on the order of ± 5 to ± 10 ppm at 25°C .

* 3) Time count precision as referred to in the above flow chart is applicable to normal temperature and actually affected by the temperature characteristics and other properties of quartz crystal units.

Course (A)

When the time count precision of each RTC is not to be adjusted, the quartz crystal unit intended for use in that RTC may have any CL value requiring no presetting. The quartz crystal unit may be subject to frequency variations which are selectable within the allowable range of time count precision. Several quartz crystal units and RTCs should be used to find the center frequency of the quartz crystal units by the method described in "P30 • Measurement of Oscillation Frequency" and then calculate an appropriate oscillation adjustment value by the method described in "P33 • Oscillation Adjustment Circuit" for writing this value to the R2033x.

Course (B)

When the time count precision of each RTC is to be adjusted within the oscillation frequency variations of the quartz crystal unit plus the frequency variations of the real-time clock ICs, it becomes necessary to correct deviations in the time count of each RTC by the method described in " P30 • Oscillation Adjustment Circuit". Such oscillation adjustment provides quartz crystal units with a wider range of allowable settings of their oscillation frequency variations and their CL values. The real-time clock IC and the quartz crystal unit intended for use in that real-time clock IC should be used to find the center frequency of the quartz crystal unit by the method described in " P30 • Measurement of Oscillation Frequency" and then confirm the center frequency thus found to fall within the range adjustable by the oscillation adjustment circuit before adjusting the oscillation frequency of the oscillator circuit. At normal temperature, the oscillation frequency of the oscillator circuit can be adjusted by up to approximately ± 0.5 ppm.

Course (C)

Course (C) together with Course (D) requires adjusting the time count precision of each RTC as well as the frequency of 32.768-kHz clock pulses output from the 32KOUT pin. Normally, the oscillation frequency of the crystal oscillator intended for use in the RTCs should be adjusted by adjusting the oscillation stabilizing capacitors CG and CD connected to both ends of the crystal oscillator. The R2033x, which incorporate the CG and the CD, require adjusting the oscillation frequency of the crystal oscillator through its CL value.

Generally, the relationship between the CL value and the CG and CD values can be represented by the following equation:

$CL = (CG \times CD)/(CG + CD) + CS$ where "CS" represents the floating capacity of the printed circuit board.

The crystal oscillator intended for use in the R2033x is recommended to have the CL value on the order of 6 to 9pF. Its oscillation frequency should be measured by the method described in " P.30 • Measurement of Oscillation Frequency ". Any crystal oscillator found to have an excessively high or low oscillation frequency (causing a time count gain or loss, respectively) should be replaced with another one having a smaller and greater CL value, respectively until another one having an optimum CL value is selected. In this case, the bit settings disabling the oscillation adjustment circuit (see " P.33 • Oscillation Adjustment Circuit") should be written to the oscillation adjustment register.

Incidentally, the high oscillation frequency of the crystal oscillator can also be adjusted by adding an external oscillation stabilization capacitor CGOUT or/and CDOUT as illustrated in the diagram below.

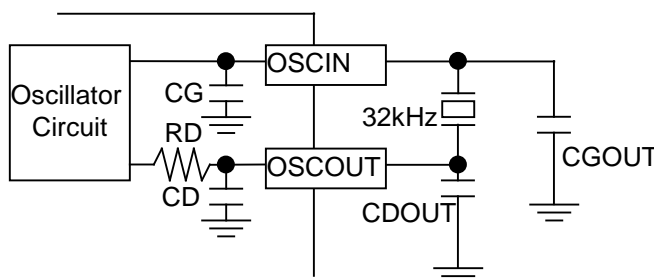

*1) The CGOUT or/and CDOUT should have a capacitance ranging from 0 to 6 pF.

* R2033K (FFP12) is the discontinued product as of July, 2016.

R2033x

NO.EA-120-160701

However, if adding CGOUT and/or CDOUT, Time keeping Voltage and Current will be worse, and it will be hard to oscillate. For reference, the data of Time keeping voltage and current when adding CGOUT=CDOUT=5pF are shown in the table below.

(T_{opt}=-40 to 85°C, V_{SS}=0v)

PIN	Item	Condition	Min.	TYP.	MAX.	UNITS
Vclk	Time Keeping Voltage	CGout=CDout=5pF	1.15		5.5	V
I _{DD}	Time Keeping Current	V _{DD} =3V, CE, SCLK, SIO, CLKC, $\overline{\text{INTR}}=0\text{v}$ 32KOUT=OFF CGout=CDout=5pF		0.55	1.20	μA

Course (D)

It is necessary to select the crystal oscillator in the same manner as in Course (C) as well as correct errors in the time count of each RTC in the same manner as in Course (B) by the method described in " P.33 • Oscillation Adjustment Circuit ".

● Oscillation Adjustment Circuit

The oscillation adjustment circuit can be used to correct a time count gain or loss with high precision by varying the number of 1-second clock pulses once per 20 seconds or 60 seconds. When DEV bit in the Oscillation Adjustment Register is set to 0, R2033x varies number of 1-second clock pulses once per 20 seconds. When DEV bit is set to 1, R2033x varies number of 1-second clock pulses once per 60 seconds. The oscillation adjustment circuit can be disabled by writing the settings of "*", 0, 0, 0, 0, 0, "*" ("*" representing "0" or "1") to the F6, F5, F4, F3, F2, F1, and F0 bits in the oscillation adjustment circuit. Conversely, when such oscillation adjustment is to be made, an appropriate oscillation adjustment value can be calculated by the equation below for writing to the oscillation adjustment circuit.

(1) When Oscillation Frequency (* 1) Is Higher Than Target Frequency (* 2) (Causing Time Count Gain)

When DEV=0:

$$\begin{aligned} \text{Oscillation adjustment value (*3)} &= \frac{(\text{Oscillation frequency} - \text{Target Frequency} + 0.1)}{\text{Oscillation frequency} \times 3.051 \times 10^{-6}} \\ &\approx (\text{Oscillation Frequency} - \text{Target Frequency}) \times 10 + 1 \end{aligned}$$

When DEV=1:

$$\begin{aligned} \text{Oscillation adjustment value (*3)} &= \frac{(\text{Oscillation frequency} - \text{Target Frequency} + 0.0333)}{\text{Oscillation frequency} \times 1.017 \times 10^{-6}} \\ &\approx (\text{Oscillation Frequency} - \text{Target Frequency}) \times 30 + 1 \end{aligned}$$

* 1) Oscillation frequency:

The clock frequency output from the 32KOUT pin at normal temperature in the manner described in "P30 • Measurement of Oscillation Frequency".

* 2) Target frequency:

Desired frequency to be set. Generally, a 32.768-kHz quartz crystal unit has such temperature characteristics as to have the highest oscillation frequency at normal temperature. Consequently, the quartz crystal unit is recommended to have target frequency settings on the order of 32.768 to 32.76810 kHz (+3.05ppm relative to 32.768 kHz). Note that the target frequency differs depending on the environment or location where the equipment incorporating the RTC is expected to be operated.

* 3) Oscillation adjustment value:

Value that is to be finally written to the F0 to F6 bits in the Oscillation Adjustment Register and is represented in 7-bit coded decimal notation.

(2) When Oscillation Frequency Is Equal To Target Frequency (Causing Time Count neither Gain nor Loss)

Oscillation adjustment value = 0, +1, -64, or -63

R2033x

NO.EA-120-160701

(3) When Oscillation Frequency Is Lower Than Target Frequency (Causing Time Count Loss)

When DEV=0:

$$\begin{aligned}\text{Oscillation adjustment value} &= \frac{(\text{Oscillation frequency} - \text{Target Frequency})}{\text{Oscillation frequency} \times 3.051 \times 10^{-6}} \\ &\approx (\text{Oscillation Frequency} - \text{Target Frequency}) \times 10\end{aligned}$$

When DEV=1:

$$\begin{aligned}\text{Oscillation adjustment value} &= \frac{(\text{Oscillation frequency} - \text{Target Frequency})}{\text{Oscillation frequency} \times 1.017 \times 10^{-6}} \\ &\approx (\text{Oscillation Frequency} - \text{Target Frequency}) \times 30\end{aligned}$$

Oscillation adjustment value calculations are exemplified below

(A) For an oscillation frequency = 32768.85Hz and a target frequency = 32768.05Hz

When setting DEV bit to 0:

$$\begin{aligned}\text{Oscillation adjustment value} &= (32768.85 - 32768.05 + 0.1) / (32768.85 \times 3.051 \times 10^{-6}) \\ &\approx (32768.85 - 32768.05) \times 10 + 1 \\ &= 9.001 \approx 9\end{aligned}$$

In this instance, write the settings (DEV,F6,F5,F4,F3,F2,F1,F0)=(0,0,0,0,1,0,0,1) in the oscillation adjustment register. Thus, an appropriate oscillation adjustment value in the presence of any time count gain represents a distance from 01h.

When setting DEV bit to 1:

$$\begin{aligned}\text{Oscillation adjustment value} &= (32768.85 - 32768.05 + 0.0333) / (32768.85 \times 1.017 \times 10^{-6}) \\ &\approx (32768.85 - 32768.05) \times 30 + 1 \\ &= 25.00 \approx 25\end{aligned}$$

In this instance, write the settings (DEV,F6,F5,F4,F3,F2,F1,F0)=(1,0,0,1,1,0,0,1) in the oscillation adjustment register.

(B) For an oscillation frequency = 32762.22Hz and a target frequency = 32768.05Hz

When setting DEV bit to 0:

$$\begin{aligned}\text{Oscillation adjustment value} &= (32762.22 - 32768.05) / (32762.22 \times 3.051 \times 10^{-6}) \\ &\approx (32762.22 - 32768.05) \times 10 \\ &= -58.325 \approx -58\end{aligned}$$

To represent an oscillation adjustment value of -58 in 7-bit coded decimal notation, subtract 58 (3Ah) from 128 (80h) to obtain 46h. In this instance, write the settings of (DEV,F6,F5,F4,F3,F2,F1,F0) = (0,1,0,0,0,1,1,0) in the oscillation adjustment register. Thus, an appropriate oscillation adjustment value in the presence of any time count loss represents a distance from 80h.

When setting DEV bit to 1:

$$\begin{aligned}\text{Oscillation adjustment value} &= (32762.22 - 32768.05) / (32762.22 \times 1.017 \times 10^{-6}) \\ &\approx (32762.22 - 32768.05) \times 30 \\ &= -174.97 \approx -175\end{aligned}$$

Oscillation adjustment value can be set from -62 to 63. Then, in this case, Oscillation adjustment value is out of range.

(4) Difference between DEV=0 and DEV=1

Difference between DEV=0 and DEV=1 is following,

	DEV=0	DEV=1
Maximum value range	-189.2ppm to 189.2ppm	-62ppm to 63ppm
Minimum resolution	3ppm	1ppm

Notes:

If following 3 conditions are completed, actual clock adjustment value could be different from target adjustment value that set by oscillator adjustment function.

1. Using oscillator adjustment function
2. Access to R2033x at random, or synchronized with external clock that has no relation to R2033x, or synchronized with periodic interrupt in pulse mode.
3. Access to R2033x more than 2 times per each second on average.

For more details, please contact to Ricoh.

● **How to evaluate the clock gain or loss**

The oscillator adjustment circuit is configured to change time counts of 1 second on the basis of the settings of the oscillation adjustment register once in 20 seconds or 60 seconds. The oscillation adjustment circuit does not effect the frequency of 32768Hz-clock pulse output from the 32KOUT pin. Therefore, after writing the oscillation adjustment register, we cannot measure the clock error with probing 32KOUT clock pulses. The way to measure the clock error as follows:

(1) Output a 1Hz clock pulse of Pulse Mode with interrupt pin

Set (0,0,x,x,0,0,1,1) to Control Register 1 at address Eh.

(2) After setting the oscillation adjustment register, 1Hz clock period changes every 20seconds (or every 60 seconds) like next page figure.

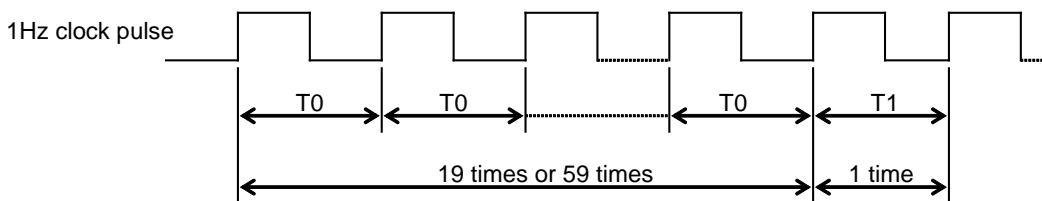

Measure the interval of T0 and T1 with frequency counter. A frequency counter with 7 or more digits is recommended for the measurement.

(3) Calculate the typical period from T0 and T1

When DEV=0:

$$T = (19 \times T0 + 1 \times T1) / 20$$

When DEV=1:

$$T = (59 \times T0 + 1 \times T1) / 60$$

Calculate the time error from T.

R2033x

NO.EA-120-160701

Power-on Reset, Oscillation Halt Sensing, and Supply Voltage Monitoring

- PON, \overline{XST} , and VDET

The power-on reset circuit is configured to reset control register1, 2, and clock adjustment register when VDD power up from 0v. The oscillation halt sensing circuit is configured to record a halt on oscillation by 32.768-kHz clock pulses. The supply voltage monitoring circuit is configured to record a drop in supply voltage below a threshold voltage of 1.6 or 1.3v.

Each function has a monitor bit. I.e. the PON bit is for the power-on reset circuit, and \overline{XST} bit is for the oscillation halt sensing circuit, and VDET is for the supply voltage monitoring circuit. PON and VDET bits are activated to "H". However, \overline{XST} bit is activated to "L". The PON and VDET accept only the writing of 0, but \overline{XST} accepts the writing of 0 and 1. The PON bit is set to 1, when VDD power-up from 0V, but VDET is set to 0, and \overline{XST} is indefinite.

The functions of these three monitor bits are shown in the table below.

	PON	\overline{XST}	VDET
Function	Monitoring for the power-on reset function	Monitoring for the oscillation halt sensing function	a drop in supply voltage below a threshold voltage of 1.6 or 1.3v
Address	D4 in Address Fh	D5 in Address Fh	D6 in Address Fh
Activated	High	Low	High
When VDD power up from 0v	1	indefinite	0
accept the writing	0 only	Both 0 and 1	0 only

The relationship between the PON, \overline{XST} , and VDET is shown in the table below.

PON	\overline{XST}	VDET	Conditions of supply voltage and oscillation	Condition of oscillator, and back-up status
0	0	0	Halt on oscillation, but no drop in VDD supply voltage below threshold voltage	Halt on oscillation cause of condensation etc.
0	0	1	Halt on oscillation and drop in VDD supply voltage below threshold voltage, but no drop to 0V	Halt on oscillation cause of drop in back-up battery voltage
0	1	0	No drop in VDD supply voltage below threshold voltage and no halt in oscillation	Normal condition
0	1	1	Drop in VDD supply voltage below threshold voltage and no halt on oscillation	No halt on oscillation, but drop in back-up battery voltage
1	0	*	Drop in supply voltage to 0v	Power-up from 0v,
1	1	*	Instantaneous power-down	Time data is unreliable.

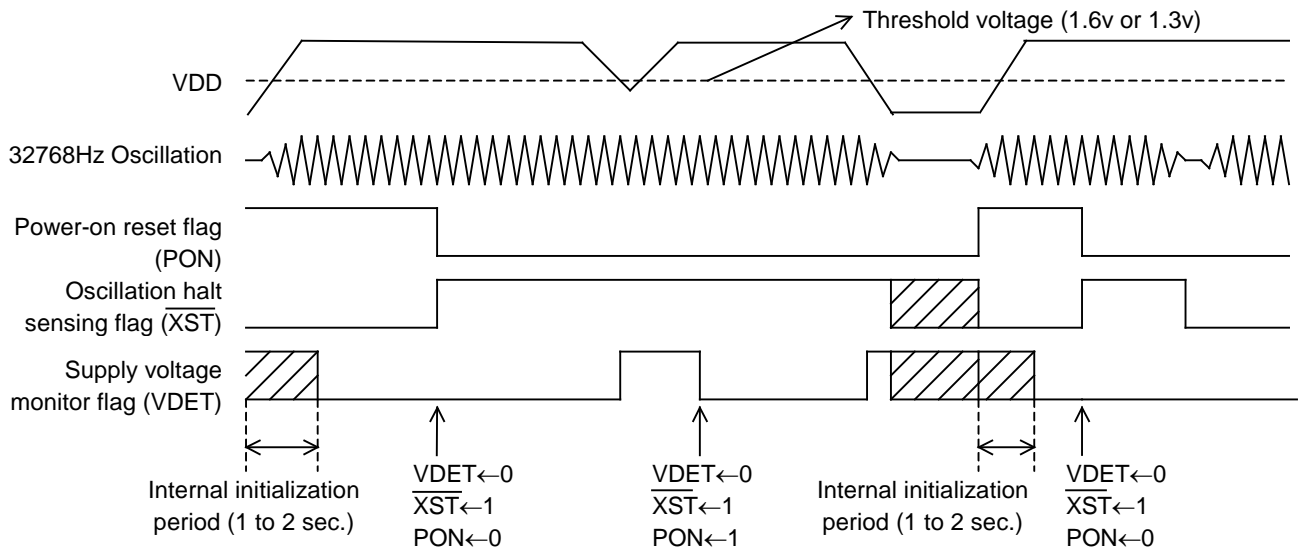

When the PON bit is set to 1 in the control register 2, the DEV, F6 to F0, WALE, DALE, $\overline{12/24}$, $\overline{CLEN2}$, TEST, CT2, CT1, CT0, VDSL, VDET, $\overline{CLEN1}$, CTFG, WAFG, and DAFG bits are reset to 0 in the oscillation adjustment register, the control register 1, and the control register 2. The PON bit is also set to 1 at power-on from 0v.

< Considerations in Using Oscillation Halt Sensing Circuit >

Be sure to prevent the oscillation halt sensing circuit from malfunctioning by preventing the following:

- 1) Instantaneous power-down on the VDD
- 2) Condensation on the crystal oscillator
- 3) On-board noise to the crystal oscillator
- 4) Applying to individual pins voltage exceeding their respective maximum ratings

In particular, note that the \overline{XST} bit may fail to be set to 0 in the presence of any applied supply voltage as illustrated below in such events as backup battery installation. Further, give special considerations to prevent excessive chattering in the oscillation halt sensing circuit.



R2033x

NO.EA-120-160701

• Voltage Monitoring Circuit

The supply monitoring circuit is configured to conduct a sampling operation during an interval of 7.8ms per second to check for a drop in supply voltage below a threshold voltage of 1.6 or 1.3v for the VDSL bit setting of 0 (the default setting) or 1, respectively, in the Control Register 2, thus minimizing supply current requirements as illustrated in the timing chart below. This circuit suspends a sampling operation once the VDET bit is set to 1 in the Control Register 2. The supply voltage monitor is useful for back-up battery checking.

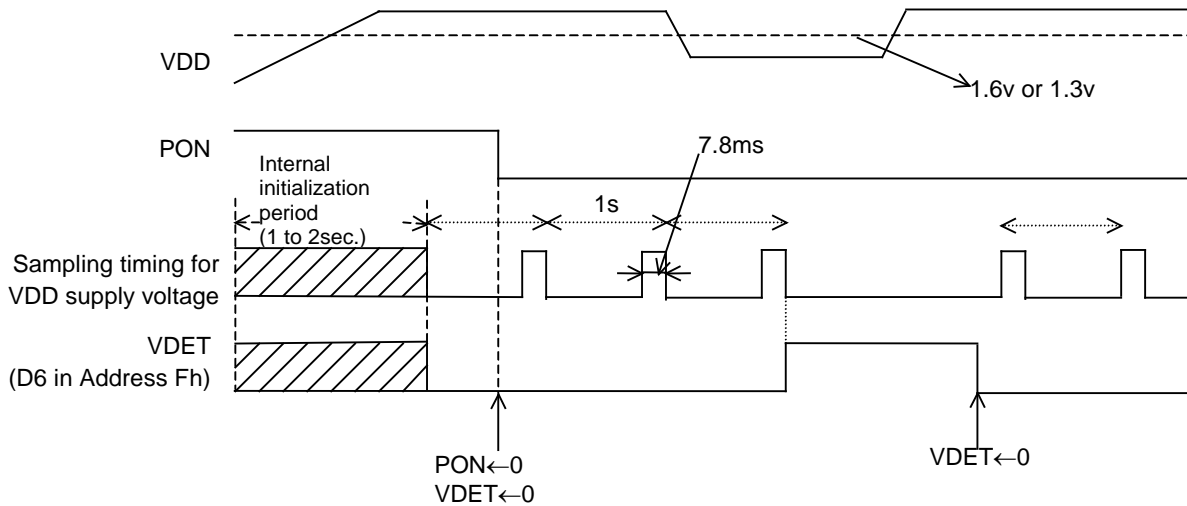

<Precautions for Using Voltage Monitoring Circuit>

After writing to the second counter, reset a VDET flag (writing 0) once for defining a value of VDET flag.

Alarm and Periodic Interrupt

The R2033x incorporates the alarm interrupt circuit and the periodic interrupt circuit that are configured to generate alarm signals and periodic interrupt signals for output from the $\overline{\text{INTR}}$ pin as described below.

(1) Alarm Interrupt Circuit

The alarm interrupt circuit is configured to generate alarm signals for output from the $\overline{\text{INTR}}$, which is driven low (enabled) upon the occurrence of a match between current time read by the time counters (the day-of-week, hour, and minute counters) and alarm time preset by the alarm registers (the Alarm_W registers intended for the day-of-week, hour, and minute digit settings and the Alarm_D registers intended for the hour and minute digit settings).

(2) Periodic Interrupt Circuit

The periodic interrupt circuit is configured to generate either clock pulses in the pulse mode or interrupt signals in the level mode for output from the $\overline{\text{INTR}}$ pin depending on the CT2, CT1, and CT0 bit settings in the control register 1.

The above two types of interrupt signals are monitored by the flag bits (i.e. the WAFG, DAFG, and CTFG bits in the Control Register 2) and enabled or disabled by the enable bits (i.e. the WALE, DALE, CT2, CT1, and CT0 bits in the Control Register 1) as listed in the table below.

	Flag bits	Enable bits
Alarm_W	WAFG (D1 at Address Fh)	WALE (D7 at Address Eh)
Alarm_D	DAFG (D0 at Address Fh)	DALE (D6 at Address Eh)
Peridic interrupt	CTFG (D2 at Address Fh)	CT2=CT1=CT0=0 (These bit setting of "0" disable the Periodic Interrupt) (D2 to D0 at Address Eh)

- * At power-on, when the WALE, DALE, CT2, CT1, and CT0 bits are set to 0 in the Control Register 1, the $\overline{\text{INTR}}$ pin is driven high (disabled).
- * When two types of interrupt signals are output simultaneously from the $\overline{\text{INTR}}$ pin, the output from the $\overline{\text{INTR}}$ pin becomes an OR waveform of their negative logic.

Example: Combined Output to $\overline{\text{INTR}}$ Pin Under Control of Alarm_D and Periodic Interrupt

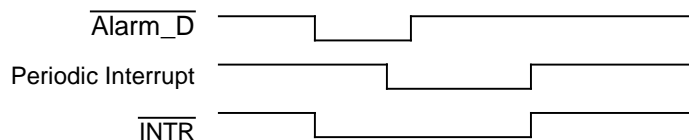

In this event, which type of interrupt signal is output from the $\overline{\text{INTR}}$ pin can be confirmed by reading the DAFG, and CTFG bit settings in the Control Register 2.

R2033x

NO.EA-120-160701

● Alarm Interrupt

The alarm interrupt circuit is controlled by the enable bits (i.e. the WALE and DALE bits in the Control Register 1) and the flag bits (i.e. the WAFG and DAFG bits in the Control Register 2). The enable bits can be used to enable this circuit when set to 1 and to disable it when set to 0. When intended for reading, the flag bits can be used to monitor alarm interrupt signals. When intended for writing, the flag bits will cause no event when set to 1 and will drive high (disable) the alarm interrupt circuit when set to 0.

The enable bits will not be affected even when the flag bits are set to 0. In this event, therefore, the alarm interrupt circuit will continue to function until it is driven low (enabled) upon the next occurrence of a match between current time and preset alarm time.

The alarm function can be set by presetting desired alarm time in the alarm registers (the Alarm_W Registers for the day-of-week digit settings and both the Alarm_W Registers and the Alarm_D Registers for the hour and minute digit settings) with the WALE and DALE bits once set to 0 and then to 1 in the Control Register 1. Note that the WALE and DALE bits should be once set to 0 in order to disable the alarm interrupt circuit upon the coincidental occurrence of a match between current time and preset alarm time in the process of setting the alarm function.

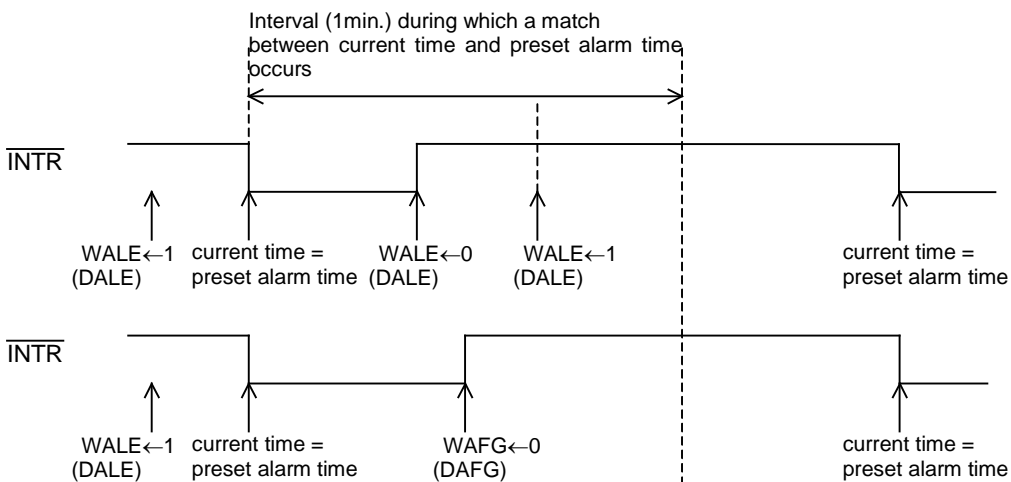

After setting WALE(DALE) to 0, Alarm registers is set to current time, and WALE(DALE) is set to 1, $\overline{\text{INTR}}$ will be not driven to "L" immediately, $\overline{\text{INTR}}$ will be driven to "L" at next alarm setting time.

● **Periodic Interrupt**

Setting of the periodic selection bits (CT2 to CT0) enables periodic interrupt to the CPU. There are two waveform modes: pulse mode and level mode. In the pulse mode, the output has a waveform duty cycle of around 50%. In the level mode, the output is cyclically driven low and, when the CTFG bit is set to 0, the output is return to High (OFF).

CT2	CT1	CT0	Description	
			Wave form mode	Interrupt Cycle and Falling Timing
0	0	0	-	OFF(H)
0	0	1	-	Fixed at "L"
0	1	0	Pulse Mode *1)	2Hz(Duty50%)
0	1	1	Pulse Mode *1)	1Hz(Duty50%)
1	0	0	Level Mode *2)	Once per 1 second (Synchronized with Second counter increment)
1	0	1	Level Mode *2)	Once per 1 minute (at 00 seconds of every Minute)
1	1	0	Level Mode *2)	Once per hour (at 00 minutes and 00 Seconds of every hour)
1	1	1	Level Mode *2)	Once per month (at 00 hours, 00 minutes, and 00 seconds of first day of every month)

(Default)

*1) Pulse Mode:

2-Hz and 1-Hz clock pulses are output in synchronization with the increment of the second counter as illustrated in the timing chart below.

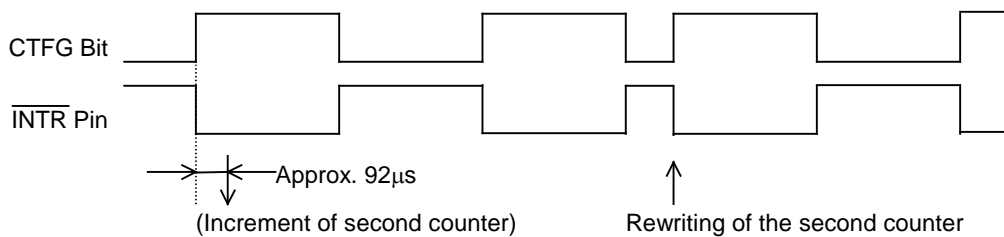

In the pulse mode, the increment of the second counter is delayed by approximately 92 μs from the falling edge of clock pulses. Consequently, time readings immediately after the falling edge of clock pulses may appear to lag behind the time counts of the real-time clocks by approximately 1 second. Rewriting the second counter will reset the other time counters of less than 1 second, driving the $\overline{\text{INTR}}$ pin low.

*2) Level Mode:

Periodic interrupt signals are output with selectable interrupt cycle settings of 1 second, 1 minute, 1 hour, and 1 month. The increment of the second counter is synchronized with the falling edge of periodic interrupt signals. For example, periodic interrupt signals with an interrupt cycle setting of 1 second are output in synchronization with the increment of the second counter as illustrated in the timing chart below.

R2033x

NO.EA-120-160701

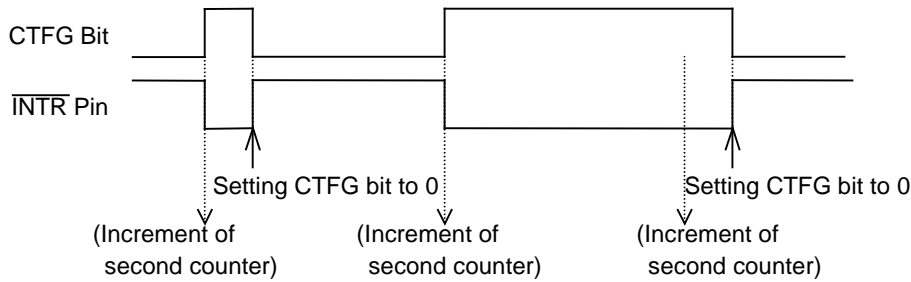

*1), *2) When the oscillation adjustment circuit is used, the interrupt cycle will fluctuate once per 20sec. as follows:

Pulse Mode: The "L" period of output pulses will increment or decrement by a maximum of $\pm 3.784\text{ms}$. For example, 1-Hz clock pulses will have a duty cycle of $50 \pm 0.3784\%$.

Level Mode: A periodic interrupt cycle of 1 second will increment or decrement by a maximum of $\pm 3.784\text{ms}$.

● **32-kHz CLOCK OUTPUT**

For the R2033x, 32.768-kHz clock pulses are output from the 32KOUT pin when either the $\overline{\text{CLEN1}}$ bit in the Control Register 2 or the $\overline{\text{CLEN2}}$ bit in the Control Register 1 is set to 0 when the CLKC pin is set to high. If the condition is not satisfied, the output is set to low.

$\overline{\text{CLEN1}}$ (D3 at Address Fh)	$\overline{\text{CLEN2}}$ (D4 at Address Eh)	CLKC pin input	32KOUT PIN (CMOS push-pull output)
1	1	*	"L"
*	*	L	Clock pulses
0(Default)	*	H	
*	0(Default)	H	

The 32KOUT pin output is synchronized with the $\overline{\text{CLEN1}}$ and $\overline{\text{CLEN2}}$ bit and CLKC pin settings as illustrated in the timing chart below.

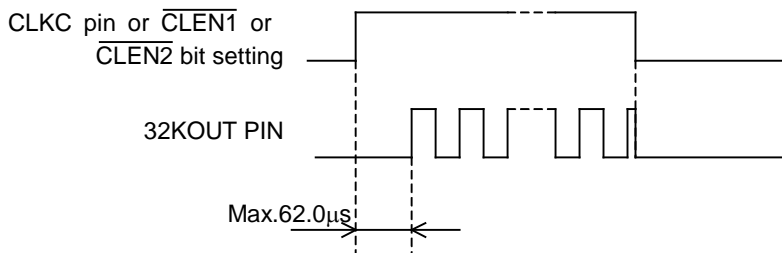

Typical Applications

• Typical Power Circuit Configurations

Sample circuit configuration 1

R1163xxx1B is a series regulator with the reverse current protection circuit. The CE pin should be pull-up to system power supply voltage, and ECO pin should be connect to system power supply or VSS. Please select VOUT voltage equal to the CPU power supply voltage that interfaces to R2033x and SRAM.

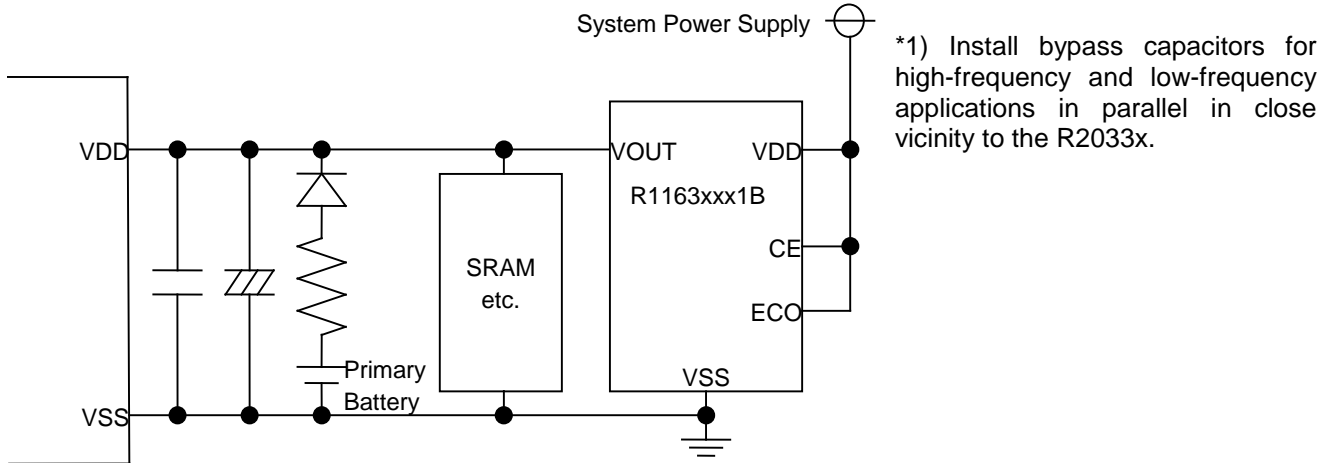

Sample circuit configuration 2

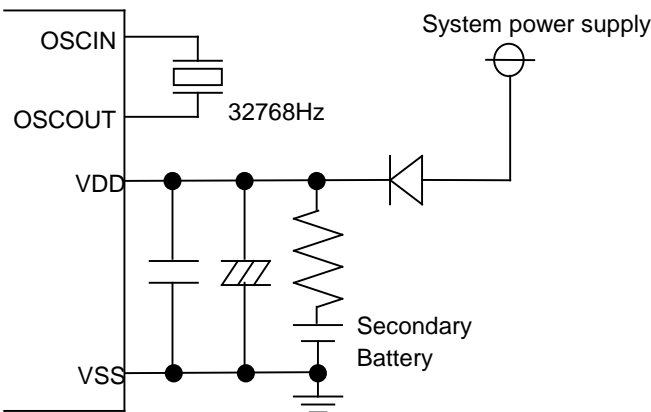
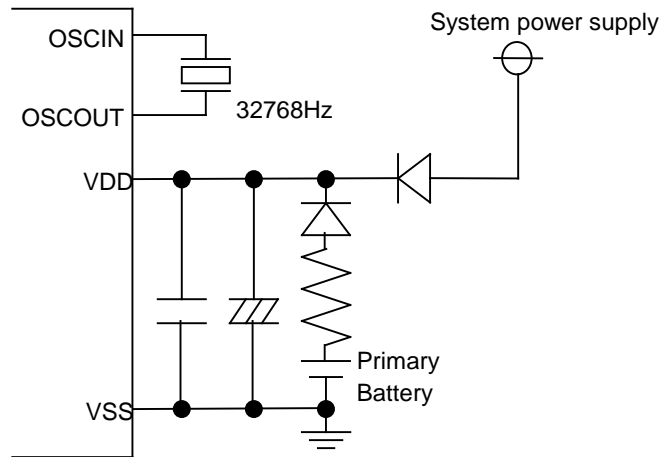

R2033x

NO.EA-120-160701

• Connection of $\overline{\text{INTR}}$ Pin

The $\overline{\text{INTR}}$ pin follows the N-channel open drain output logic and contains no protective diode on the power supply side. As such, it can be connected to a pull-up resistor of up to 5.5v regardless of supply voltage.

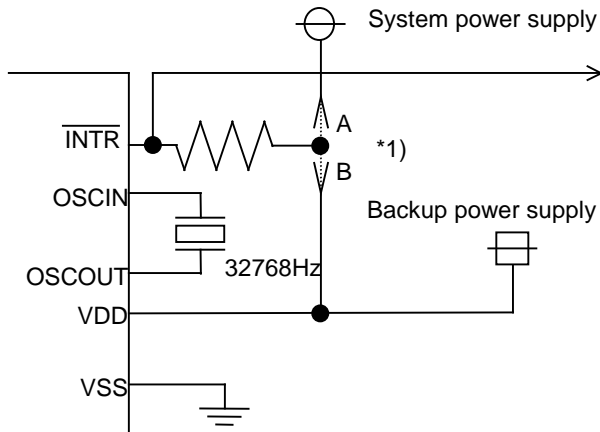

*1) Depending on whether the $\overline{\text{INTR}}$ pin is used during battery backup, it should be connected to a pull-up resistor at the following different positions:

- (1) Position A in the left diagram when it is not to be used during battery backup.
- (2) Position B in the left diagram when it is to be used during battery backup.

• Connection of 32KOUT Pin

As the 32KOUT pin is CMOS output, the supply voltage of the R2033x and any devices to be connected should be the same. When the device is powered down, the 32KOUT output pin should be disabled.

When the CLKC pin is connected to the system power supply through the pull-up resistor, the pull-up resistor should be 0Ω to $10k\Omega$, and the 32KOUT pin should be connect to the host device through the resistor (approx. $10k\Omega$)

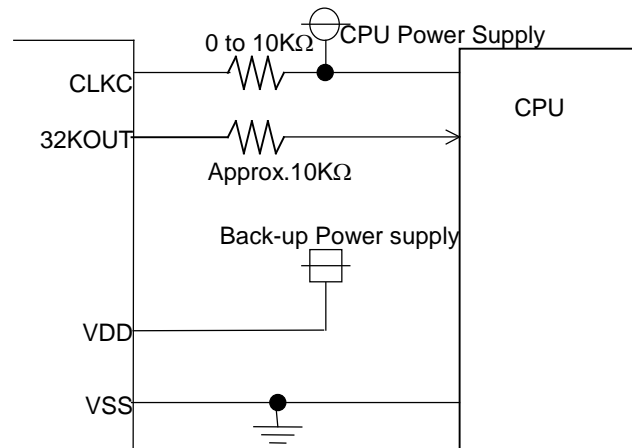
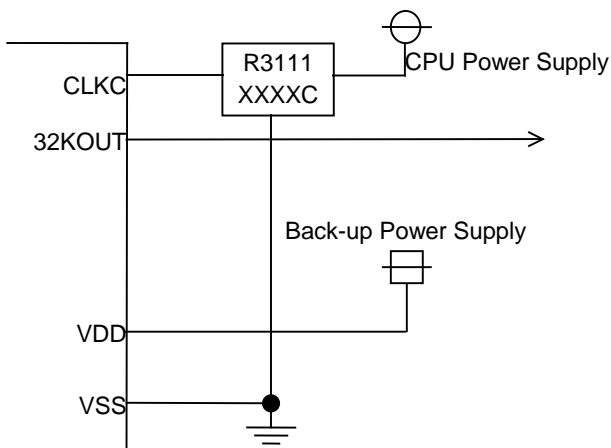

Typical Characteristics

Test circuit

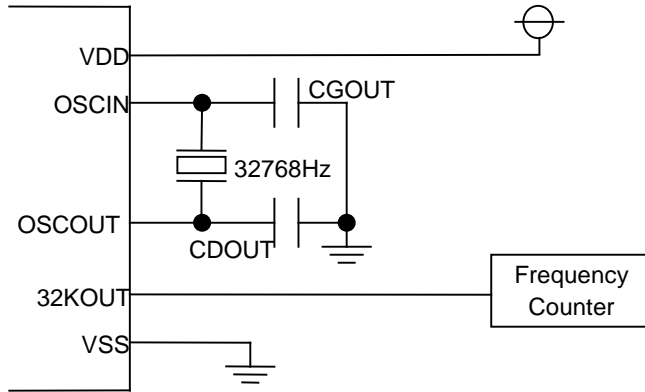

X'tal : 32.768kHz
 (R1=50kΩ typ)
 (CL=6pF to 9pF)
 T_{opt} : 25°C
 Output pins : Open

Timekeeping Current vs. Supply Voltage
 (with no 32kHz clock output)
 (Output=Open, T_{opt}=25°C)

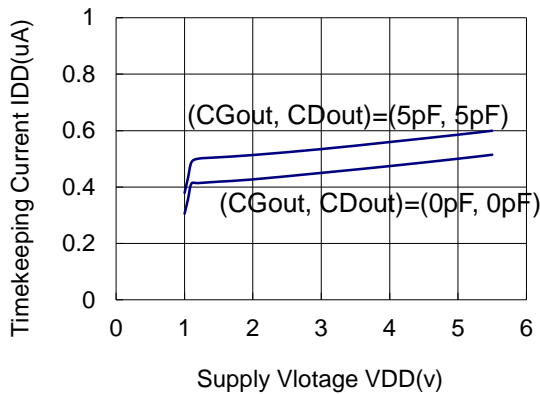

Timekeeping Current vs. Supply Voltage
 (with 32kHz clock output)
 (Output=Open, T_{opt}=25°C)

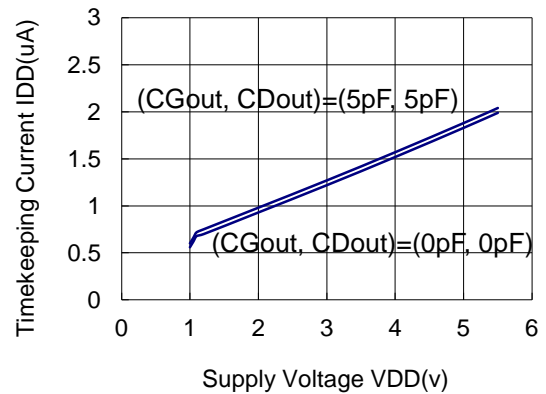

CPU Access Current vs. SCLK Clock Frequency
 (Output pins=Open, T_{opt}=25°C, CGout=CDout=0pF)

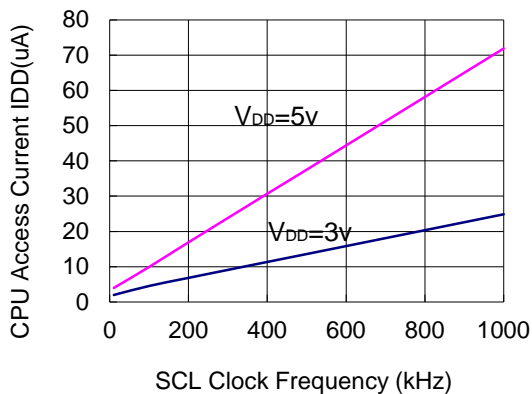

Timekeeping Current vs. Operating Temperature
 (Output pins=Open, CGout=CDout=0pF)

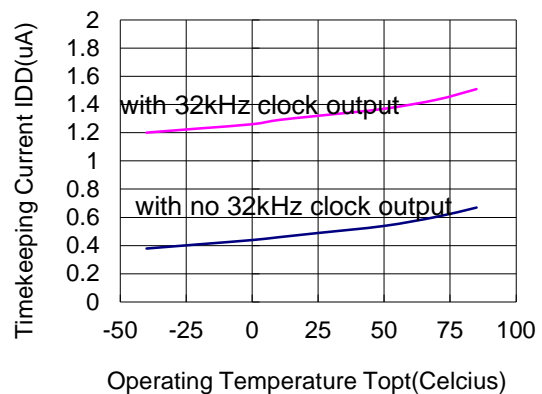

R2033x

NO.EA-120-160701

Oscillation Frequency Deviation vs. External CGout
(V_{DD}=3V, T_{opt}=25°C, CGout=CDout=0pF as standard)

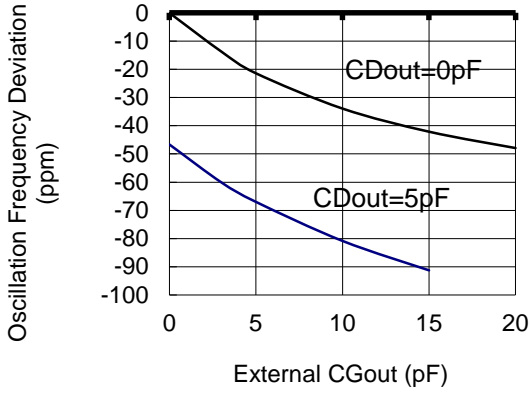

Oscillation Frequency Deviation vs. Supply Voltage
(T_{opt}=25°C, V_{DD}=3V as standard)

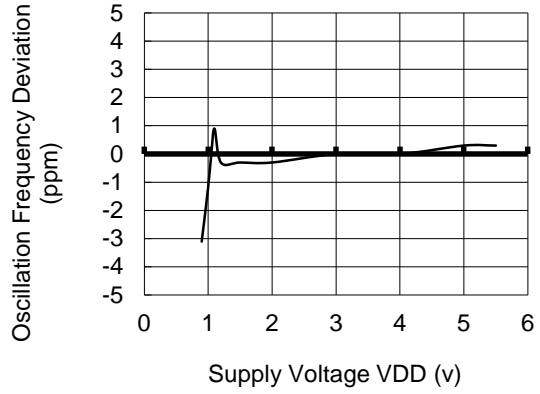

Oscillation Frequency Deviation vs. Operating Temperature
(V_{DD}=3V, T_{opt}=25°C as standard)

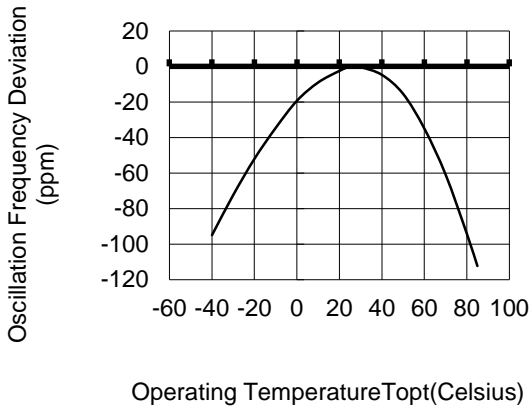

V_{OL} vs. I_{OL} ($\overline{\text{INTR}}$ pin)
(T_{opt}=25°C)

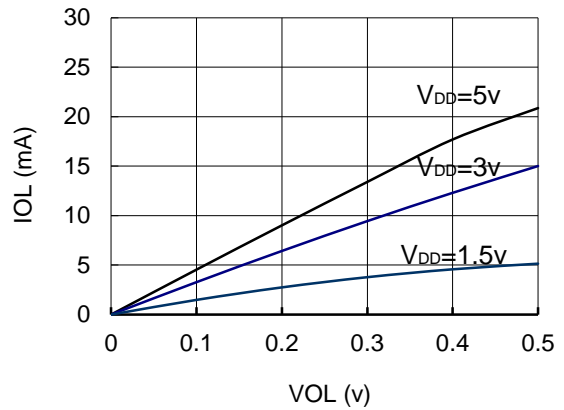

Typical Software-based Operations

• Initialization at Power-on

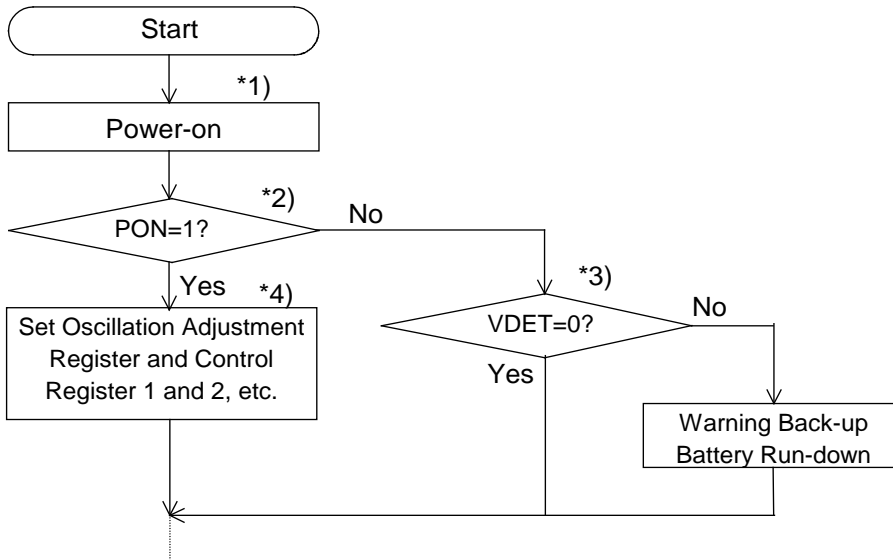

*1) After power-on from 0 volt, the start of oscillation and the process of internal initialization require a time span on 1 to 2 seconds, so that access should be done after the lapse of this time span or more.

*2) The PON bit setting of 0 in the Control Register 1 indicates power-on from backup battery and not from 0v. For further details, see "P.36 • PON, \overline{XST} , VDET".

*3) This step is not required when the supply voltage monitoring circuit is not used. When using this circuit, note as follows.

After writing to the second counter, reset a VDET flag (writing 0) once for defining a value of VDET flag.

*4) This step involves ordinary initialization including the Oscillation Adjustment Register and interrupt cycle settings, etc.

• Writing of Time and Calendar Data

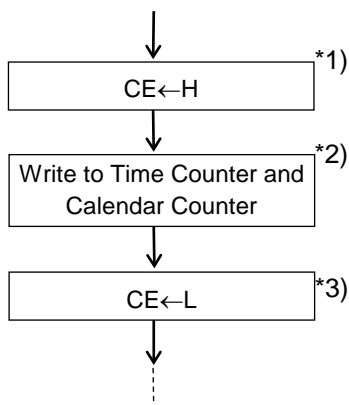

*1) When writing to clock and calendar counters, do not insert CE=L until all times from second to year have been written to prevent error in writing time. (Detailed in "P.27 • Considerations in Reading and Writing Time Data under special condition".

*2) Any writing to the second counter will reset divider units lower than the second digits. After writing to the second counter, reset a VDET flag (writing 0) once for defining a value of VDET flag.

The R2033x may also be initialized not at power-on but in the process of writing time and calendar data.

R2033x

NO.EA-120-160701

• Reading Time and Calendar Data

(1) Ordinary Process of Reading Time and Calendar Data

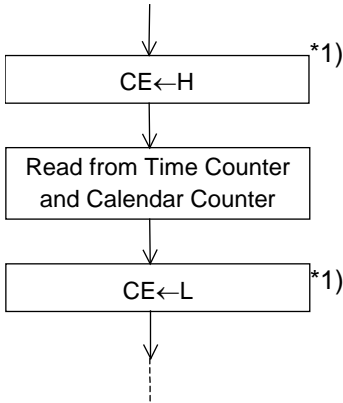

*1) When reading to clock and calendar counters, do not insert CE=L until all times from second to year have been read to prevent error in reading time. (Detailed in "P.27 •Considerations in Reading and Writing Time Data under special condition".

(2) Basic Process of Reading Time and Calendar Data with Periodic Interrupt Function

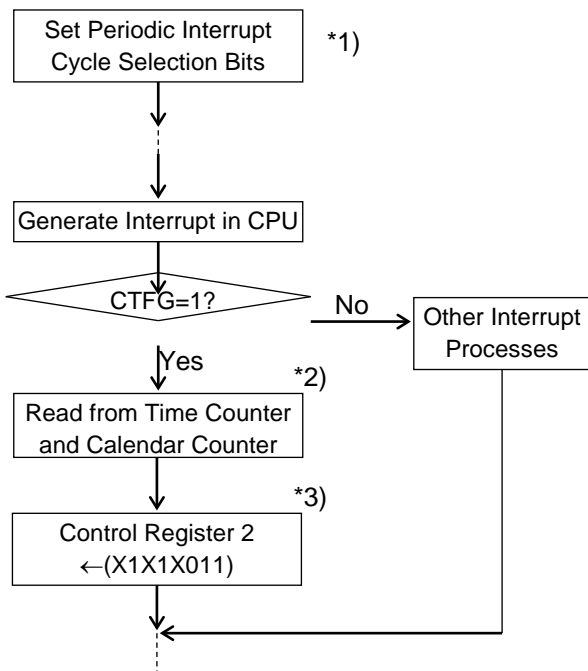

*1) This step is intended to select the level mode as a waveform mode for the periodic interrupt function.

*2) This step must be completed within 0.5 second.

*3) This step is intended to set the CTFG bit to 0 in the Control Register 2 to cancel an interrupt to the CPU.

(3) Applied Process of Reading Time and Calendar Data with Periodic Interrupt Function

Time data need not be read from all the time counters when used for such ordinary purposes as time count indication. This applied process can be used to read time and calendar data with substantial reductions in the load involved in such reading.

For Time Indication in "Day-of-Month, Day-of-week, Hour, Minute, and Second" Format:

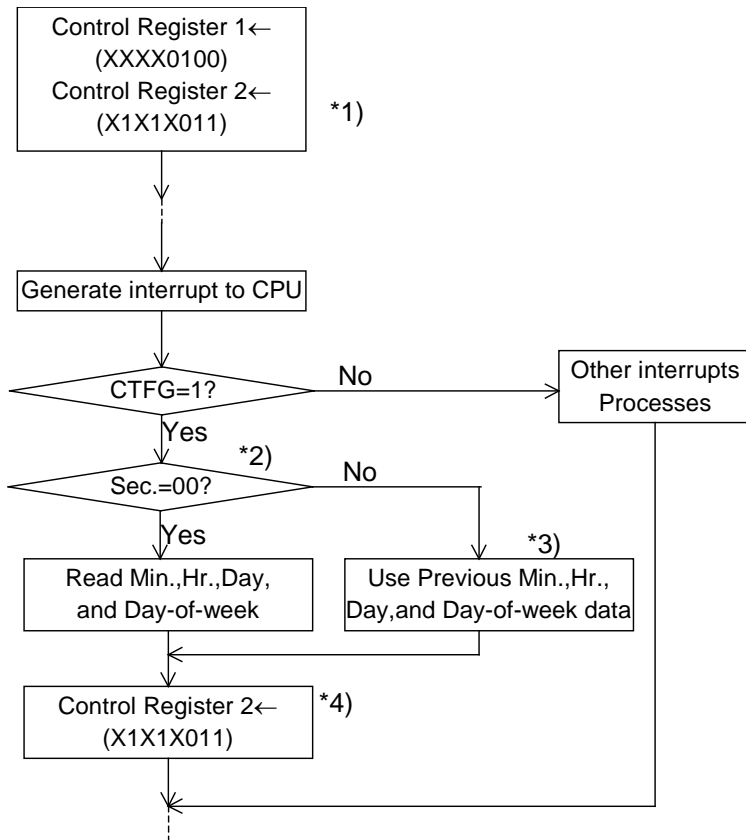

*1) This step is intended to select the level mode as a waveform mode for the periodic interrupt function.

*2) This step must be completed within 0.5 sec.

*3) This step is intended to read time data from all the time counters only in the first session of reading time data after writing time data.

*4) This step is intended to set the CTFG bit to 0 in the Control Register 2 to cancel an interrupt to the CPU.

R2033x

NO.EA-120-160701

● Interrupt Process

(1) Periodic Interrupt

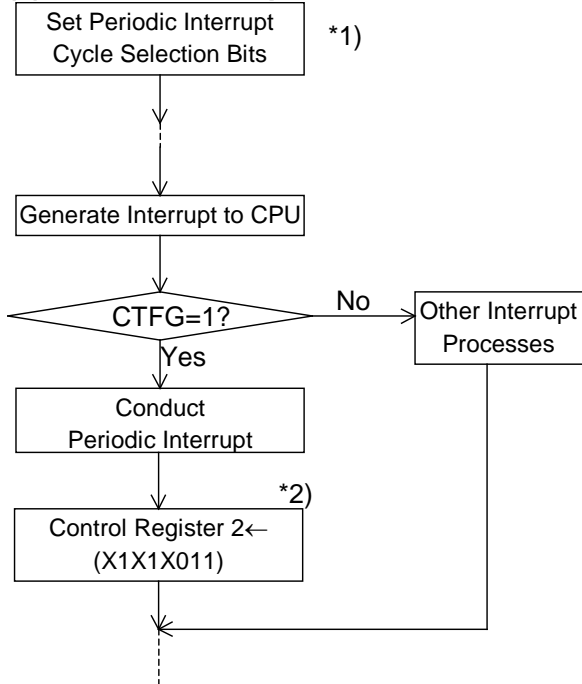

*1) This step is intended to select the level mode as a waveform mode for the periodic interrupt function.

*2) This step is intended to set the CTFG bit to 0 in the Control Register 2 to cancel an interrupt to the CPU.

(2) Alarm Interrupt

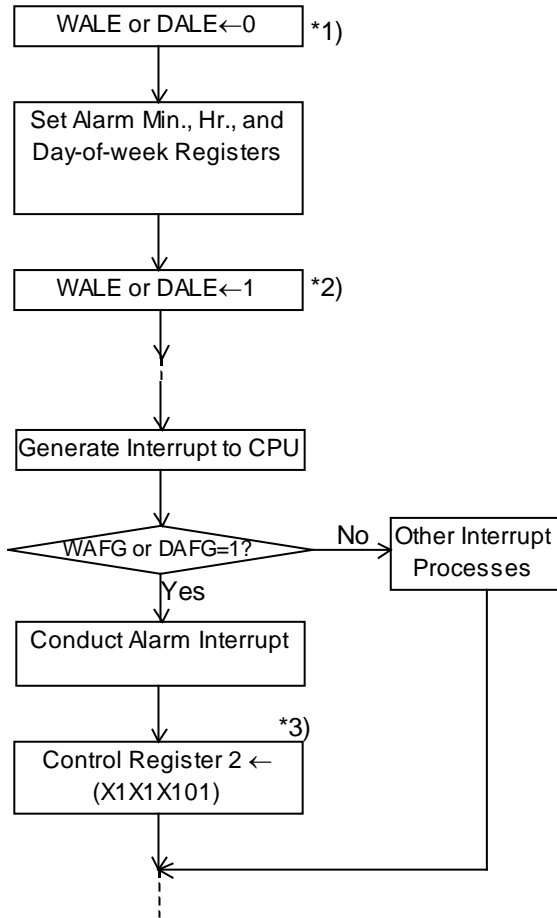

*1) This step is intended to once disable the alarm interrupt circuit by setting the WALE or DALE bits to 0 in anticipation of the coincidental occurrence of a match between current time and preset alarm time in the process of setting the alarm interrupt function.

*2) This step is intended to enable the alarm interrupt function after completion of all alarm interrupt settings.

*3) This step is intended to once cancel the alarm interrupt function by writing the settings of "X,1,X, 1,X,1,0,1" and "X,1,X,1,X,1,1,0" to the Alarm_W Registers and the Alarm_D Registers, respectively.



1. The products and the product specifications described in this document are subject to change or discontinuation of production without notice for reasons such as improvement. Therefore, before deciding to use the products, please refer to Ricoh sales representatives for the latest information thereon.
2. The materials in this document may not be copied or otherwise reproduced in whole or in part without prior written consent of Ricoh.
3. Please be sure to take any necessary formalities under relevant laws or regulations before exporting or otherwise taking out of your country the products or the technical information described herein.
4. The technical information described in this document shows typical characteristics of and example application circuits for the products. The release of such information is not to be construed as a warranty of or a grant of license under Ricoh's or any third party's intellectual property rights or any other rights.
5. The products listed in this document are intended and designed for use as general electronic components in standard applications (office equipment, telecommunication equipment, measuring instruments, consumer electronic products, amusement equipment etc.). Those customers intending to use a product in an application requiring extreme quality and reliability, for example, in a highly specific application where the failure or misoperation of the product could result in human injury or death (aircraft, spacevehicle, nuclear reactor control system, traffic control system, automotive and transportation equipment, combustion equipment, safety devices, life support system etc.) should first contact us.
6. We are making our continuous effort to improve the quality and reliability of our products, but semiconductor products are likely to fail with certain probability. In order to prevent any injury to persons or damages to property resulting from such failure, customers should be careful enough to incorporate safety measures in their design, such as redundancy feature, fire containment feature and fail-safe feature. We do not assume any liability or responsibility for any loss or damage arising from misuse or inappropriate use of the products.
7. Anti-radiation design is not implemented in the products described in this document.
8. The X-ray exposure can influence functions and characteristics of the products. Confirm the product functions and characteristics in the evaluation stage.
9. WLCSP products should be used in light shielded environments. The light exposure can influence functions and characteristics of the products under operation or storage.
10. There can be variation in the marking when different AOI (Automated Optical Inspection) equipment is used. In the case of recognizing the marking characteristic with AOI, please contact Ricoh sales or our distributor before attempting to use AOI.
11. Please contact Ricoh sales representatives should you have any questions or comments concerning the products or the technical information.



Ricoh is committed to reducing the environmental loading materials in electrical devices with a view to contributing to the protection of human health and the environment.

Ricoh has been providing RoHS compliant products since April 1, 2006 and Halogen-free products since April 1, 2012.

RICOH RICOH ELECTRONIC DEVICES CO., LTD.

<https://www.e-devices.ricoh.co.jp/en/>

Sales & Support Offices

Ricoh Electronic Devices Co., Ltd.

Shin-Yokohama Office (International Sales)

2-3, Shin-Yokohama 3-chome, Kohoku-ku, Yokohama-shi, Kanagawa, 222-8530, Japan
Phone: +81-50-3814-7687 Fax: +81-45-474-0074

Ricoh Americas Holdings, Inc.

675 Campbell Technology Parkway, Suite 200 Campbell, CA 95008, U.S.A.
Phone: +1-408-610-3105

Ricoh Europe (Netherlands) B.V.

Semiconductor Support Centre

Prof. W.H. Keesomlaan 1, 1183 DJ Amstelveen, The Netherlands
Phone: +31-20-5474-309

Ricoh International B.V. - German Branch

Semiconductor Sales and Support Centre

Oberrather Strasse 6, 40472 Düsseldorf, Germany
Phone: +49-211-6546-0

Ricoh Electronic Devices Korea Co., Ltd.

3F, Haesung Bldg, 504, Teheran-ro, Gangnam-gu, Seoul, 135-725, Korea
Phone: +82-2-2135-5700 Fax: +82-2-2051-5713

Ricoh Electronic Devices Shanghai Co., Ltd.

Room 403, No.2 Building, No.690 Bibo Road, Pu Dong New District, Shanghai 201203,
People's Republic of China
Phone: +86-21-5027-3200 Fax: +86-21-5027-3299

Ricoh Electronic Devices Shanghai Co., Ltd.

Shenzhen Branch

1205, Block D (Jinlong Building), Kingkey 100, Hongbao Road, Luohu District,
Shenzhen, China
Phone: +86-755-8348-7600 Ext 225

Ricoh Electronic Devices Co., Ltd.

Taipei office

Room 109, 10F-1, No.51, Hengyang Rd., Taipei City, Taiwan (R.O.C.)
Phone: +886-2-2313-1621/1622 Fax: +886-2-2313-1623

X-ON Electronics

Largest Supplier of Electrical and Electronic Components

Click to view similar products for [Real Time Clock](#) category:

Click to view products by [Nisshinbo](#) manufacturer:

Other Similar products are found below :

[DS1302Z-LF](#) [710029X](#) [879047C](#) [405800G](#) [PT7C43390LE](#) [RV-3029-C2-32.768k-OPTION-B-TB-QA](#) [RV-2123-C2-32.768k-20PPM-TA-QA](#)
[RV-3029-C2-32.768k-OPTION-A-TB-QA](#) [RV-1805-C3-32.768k-2PPM-TA-QA](#) [RV-2123-C2-32.768kHz-20PPM-TA-QC](#) [RX8900SA UC3](#)
[PURE SN](#) [RX-4035LC:B3 PURE SN](#) [RX-8564LC:B PURE SN](#) [RX-4571LC:B PURE SN](#) [RX-8803LCUB PURE SN BULK](#) [RX-8571LCB0](#)
[PURE SN](#) [RTC-8564JE](#) [MCP7940M-I/P](#) [DS3231SN#T&R](#) [DS1391U-18+](#) [DS1347T+T&R](#) [RX8900CE:UA3](#) [RX-8564LC:B3 PURE SN](#)
[PCF85063TP/1Z](#) [DS1338Z-33+T](#) [RX-4571SA:B3 PURE SN](#) [DS1340U-33+T&R](#) [RX-8571LC:B3 PURE SN](#) [PCF8583T/5.518](#) [RTC-](#)
[4543SAB](#) [RTC-72423A](#) [RX-8803LC:UB3 PURE SN](#) [RX-8803SA:UB3 PURE SN](#) [S-35390A-T8T1](#) [AB1815-T3](#) [AB-RTCMC-32.768kHz-](#)
[AIGZ-S7-T](#) [AB-RTCMC-32.768kHz-B5GA-S3-T](#) [AB-RTCMC-32.768kHz-B5ZE-S3-T](#) [AB-RTCMC-32.768kHz-EOA9-S3-D-B-T](#) [AB-](#)
[RTCMC-32.768KHZ-EOZ9-S3-HAT](#) [AB-RTCMC-32.768kHz-ZIZE-S2-T](#) [FM33256B-G](#) [DS1673E-5-LF](#) [HYM1307N](#) [HYM1302](#)
[HYM1302N](#) [PCF8563N](#) [ECS-RTC-3225-5609-TR](#) [ECS-RTC-3225-5699HS-TR](#) [9E4101AFILF](#)