

Microprocessor Supervisory Circuit with Inhibit pin

NO.EA-169-200602

OUTLINE

The R5106N is a microprocessor supervisory circuit and has high accuracy and ultra low supply current voltage detector with built-in delay circuit and watchdog timer. When the supply voltage is down across the threshold, or the watchdog timer does not detect the system clock from the microprocessor, the reset output is generated. The voltage detector circuit is used for the system reset, etc. The detector threshold is fixed internally, and the accuracy is $\pm 1.0\%$. The released delay time (Power-on Reset Delay) circuit is built-in, and output delay time is adjustable with an external capacitor, and the accuracy is $\pm 16\%$ ⁽¹⁾. When the supply voltage becomes higher than the released voltage, the reset state will be maintained during the delay time. The output type of the reset is selectable, Nch open-drain, or CMOS.

The time out period of the watchdog timer can be also set with an external capacitor, and the accuracy is $\pm 33\%$ ⁽¹⁾. There is a function to stop supervising clock by the watchdog timer (INH function). There are another 4 products by the difference of packages and the function of voltage detector and watchdog timer.

The package of R5106N is SOT-23-6.

FEATURES

- Supply Current (I_{SS})..... Typ. 11 μ A
- Operating Voltage Range (V_{DD})..... 0.9V to 6.0V

< Voltage Detector Part >

- Detector Threshold Range 1.5V to 5.5V (0.1V steps)
- Detector Threshold Accuracy $\pm 1.0\%$
- Power-on Reset Delay Time accuracy $\pm 16\%$ ⁽¹⁾ ($-40^{\circ}\text{C} \leq T_a \leq 105^{\circ}\text{C}$)
- Power-on reset delay time of the voltage detector Typ. 370ms with an external capacitor : 0.1 μ F

< Watchdog Timer Part >

- Built-in a watchdog timer's time out period accuracy $\pm 33\%$ ⁽¹⁾ ($-40^{\circ}\text{C} \leq T_a \leq 105^{\circ}\text{C}$)
- Timeout period for watchdog timer Typ. 310ms with an external capacitor : 0.1 μ F
- Reset timer for watchdog timer Typ. 34ms with an external capacitor : 0.1 μ F
- With Inhibit pin (INH) Able to stop watchdog timer
- Package SOT-23-6

APPLICATIONS

- Supervisory circuit for equipment with using microprocessors.

⁽¹⁾ Accuracy to center value of (Min.+Max.)/2

R5106N

NO.EA-169-200602

SELECTION GUIDE

The detector threshold, the output type and the taping type for the ICs can be selected at the users' request. The selection can be made with designating the part number as shown below;

Product Name	Package	Quantity per Reel	Pb Free	Halogen Free
R5106Nxx1*-TR-FE	SOT-23-6	3,000 pcs	Yes	Yes

xx: The detector threshold ($-V_{DET}$) can be designated in the range from 1.5V(15) to 5.5V(55) in 0.1V steps.

* : Designation of Output Type
(A) Nch Open Drain
(C) CMOS

Series Selection

	R5105N	R5106N	R5107G	R5108G	R5109G
Package	SOT-23-6		SSOP-8G		
With INH pin (Inhibit)	No	Yes			
2 clock input	No				Yes
With MR pin (Manual Reset)	No		Yes	No	
With SENSE pin	No			Yes	No
Remarks		C_D pin and C_{TW} pin are combined uses.		Operating Voltage Range 1.5V to 6.0V	Supply Current 11.5 μ A

BLOCK DIAGRAMS

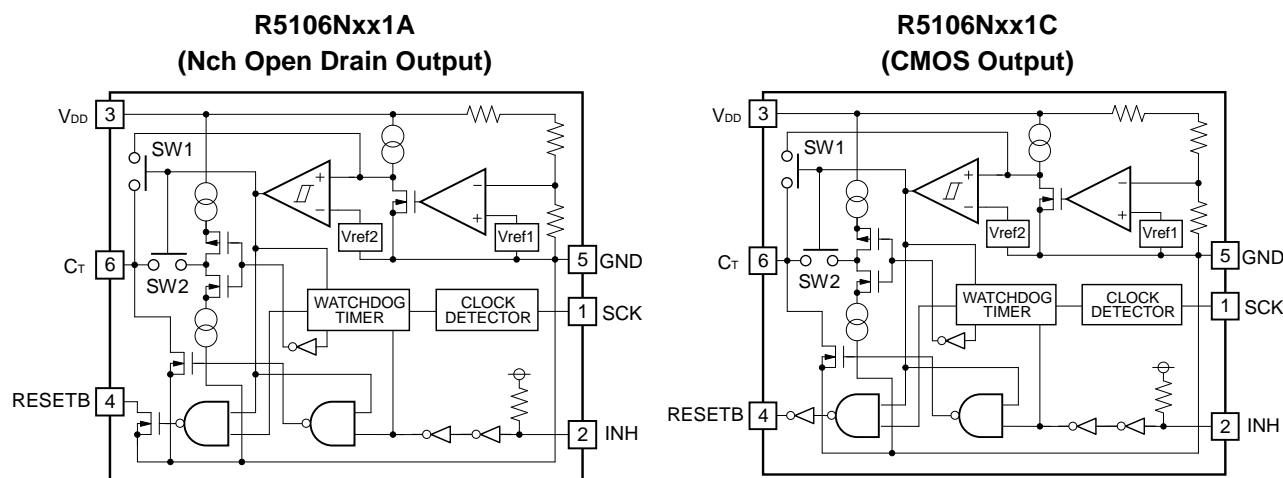

SW1: "L"=ON, SW2: "H"=ON

PIN DESCRIPTIONS

● SOT-23-6

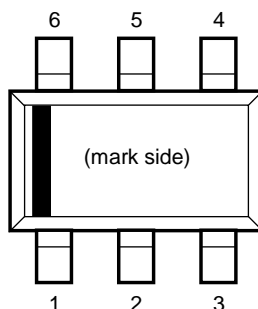

● SOT-23-6

Pin No.	Symbol	Description
1	SCK	Clock Input Pin from Microprocessor
2	INH	Inhibit Pin ("L": Inhibit the watchdog timer)
3	V _{DD}	Power supply Pin
4	RESETB	Output Pin for Reset signal of Watchdog timer and Voltage Detector. (Output "L" at detecting Detector Threshold and Watchdog Timer Reset.)
5	GND	Ground Pin
6	C _T	External Capacitor Pin for Setting Reset and Watchdog Timeout Periods and delay time of Voltage Detector

R5106N

NO.EA-169-200602

ABSOLUTE MAXIMUM RATINGS

(Ta=25°C)

Symbol	Item	Rating	Unit	
V _{DD}	Supply Voltage	-0.3 to 7.0	V	
V _{CT}	Output Voltage	Voltage of C _T Pin	-0.3 to V _{DD} + 0.3	V
V _{RESETB}		Voltage of RESETB Pin	-0.3 to 7.0	V
V _{SCK}	Input Voltage	Voltage of SCK Pin	-0.3 to 7.0	V
V _{INH}		Voltage of INH Pin	-0.3 to 7.0	V
I _{RESETB}	Output Current	Current of RESETB Pin	20	mA
P _D	Power Dissipation ⁽¹⁾ (SOT-23-6, JEDEC STD. 51-7)	660	mW	
T _j	Junction Temperature	-40 to 125	°C	
T _{stg}	Storage Temperature Range	-55 to 125	°C	

ABSOLUTE MAXIMUM RATINGS

Electronic and mechanical stress momentarily exceeded absolute maximum ratings may cause permanent damage and may degrade the life time and safety for both device and system using the device in the field. The functional operation at or over these absolute maximum ratings are not assured.

RECOMMENDED OPERATING CONDITIONS

Symbol	Item	Rating	Unit
V _{DD}	Operating Voltage	0.9 to 6.0	V
T _a	Operating Temperature Range	-40 to 105	°C

RECOMMENDED OPERATING CONDITIONS

All of electronic equipment should be designed that the mounted semiconductor devices operate within the recommended operating conditions. The semiconductor devices cannot operate normally over the recommended operating conditions, even if they are used over such ratings by momentary electronic noise or surge. And the semiconductor devices may receive serious damage when they continue to operate over the recommended operating conditions.

⁽¹⁾ Refer to *POWER DISSIPATION* for detailed information.

ELECTRICAL CHARACTERISTICS

$V_{DD}=6.0V$, $C_T=0.1\mu F$, In case of Nch Open Drain Output type, the output pin is pulled up with a resistance of $100k\Omega$ (R5106Nxx1A), unless otherwise noted.

The specification in is checked and guaranteed by design engineering at $-40^{\circ}C \leq T_a \leq 105^{\circ}C$.

R5106Nxx1A/C

(Ta=25°C)

Symbol	Item	Conditions	Min.	Typ.	Max.	Unit
I_{SS}	Supply Current	$V_{DD}=-V_{DET}+0.5V$, Clock pulse input		11	<input type="checkbox"/> 15	μA

VD Part

Symbol	Item	Conditions	Min.	Typ.	Max.	Unit
$-V_{DET}$	Detector Threshold	$T_a=25^{\circ}C$	$\times 0.990$		$\times 1.010$	V
		$-40^{\circ}C \leq T_a \leq 105^{\circ}C$	<input type="checkbox"/> 0.972		<input type="checkbox"/> 1.015	
$\Delta V_{DET}/\Delta T_a$	Detector Threshold Temperature Coefficient	$-40^{\circ}C \leq T_a \leq 105^{\circ}C$		± 100		ppm/ $^{\circ}C$
V_{HYS}	Detector Threshold Hysteresis		$\frac{-V_{DET}}{\times 0.03}$	$-V_{DET} \times 0.05$	$\frac{-V_{DET}}{\times 0.07}$	V
t_{PLH}	Output Delay Time	$C_T=0.1\mu F$ ⁽¹⁾	<input type="checkbox"/> 340	370	<input type="checkbox"/> 467	ms
I_{RESETB}	Output Current (RESETB Output pin)	Nch $V_{DD}=1.2V$, $V_{DS}=0.1V$	<input type="checkbox"/> 0.38	0.8		mA
		Pch ⁽²⁾ $V_{DD}=6.0V$, $V_{DS}=0.5V$	<input type="checkbox"/> 0.65	0.9		mA

WDT Part

Symbol	Item	Conditions	Min.	Typ.	Max.	Unit
t_{WD}	Watchdog Timeout period	$C_T=0.1\mu F$ ⁽¹⁾	<input type="checkbox"/> 230	310	<input type="checkbox"/> 450	ms
t_{WR}	Reset Hold Time of WDT	$C_T=0.1\mu F$ ⁽¹⁾	<input type="checkbox"/> 29	34	<input type="checkbox"/> 48	ms
V_{SCKH}	SCK Input "H"		$V_{DD} \times 0.8$		<input type="checkbox"/> 6.0	V
V_{SCKL}	SCK Input "L"		<input type="checkbox"/> 0		$V_{DD} \times 0.2$	V
$V_{INH H}$	INH Input "H"		<input type="checkbox"/> 1.0		<input type="checkbox"/> 6.0	V
$V_{INH L}$	INH Input "L"		<input type="checkbox"/> 0		<input type="checkbox"/> 0.35	V
R_{INH}	INH pull-up Resistance		<input type="checkbox"/> 60	110	<input type="checkbox"/> 164	$k\Omega$
t_{SCKW}	SCK Input Pulse Width	$V_{SCKL}=V_{DD} \times 0.2$ $V_{SCKH}=V_{DD} \times 0.8$	<input type="checkbox"/> 500			ns

All test items listed under *Electrical Characteristics* are done under the pulse load condition ($T_j \approx T_a = 25^{\circ}C$) except for Detector Threshold Temperature Coefficient.

⁽¹⁾ The specification does not contain the temperature characteristics of the external capacitor.

⁽²⁾ In case of CMOS type (R5105Nxx1C)

R5106N

NO.EA-169-200602

Product-specific Electrical Characteristics

Product Name	-V _{DET}						V _{HYS}		
	Ta = 25°C			-40°C ≤ Ta ≤ 105 °C			Min.	Typ.	Max.
	Min.	Typ.	Max.	Min.	Typ.	Max.			
R5106N151x	1.485	1.500	1.515	1.4580	1.500	1.5225	0.045	0.075	0.105
R5106N161x	1.584	1.600	1.616	1.5552	1.600	1.6240	0.048	0.080	0.112
R5106N171x	1.683	1.700	1.717	1.6524	1.700	1.7255	0.051	0.085	0.119
R5106N181x	1.782	1.800	1.818	1.7496	1.800	1.8270	0.054	0.090	0.126
R5106N191x	1.881	1.900	1.919	1.8468	1.900	1.9285	0.057	0.095	0.133
R5106N201x	1.980	2.000	2.020	1.9440	2.000	2.0300	0.060	0.100	0.140
R5106N211x	2.079	2.100	2.121	2.0412	2.100	2.1315	0.063	0.105	0.147
R5106N221x	2.178	2.200	2.222	2.1384	2.200	2.2330	0.066	0.110	0.154
R5106N231x	2.277	2.300	2.323	2.2356	2.300	2.3345	0.069	0.115	0.161
R5106N241x	2.376	2.400	2.424	2.3328	2.400	2.4360	0.072	0.120	0.168
R5106N251x	2.475	2.500	2.525	2.4300	2.500	2.5375	0.075	0.125	0.175
R5106N261x	2.574	2.600	2.626	2.5272	2.600	2.6390	0.078	0.130	0.182
R5106N271x	2.673	2.700	2.727	2.6244	2.700	2.7405	0.081	0.135	0.189
R5106N281x	2.772	2.800	2.828	2.7216	2.800	2.8420	0.084	0.140	0.196
R5106N291x	2.871	2.900	2.929	2.8188	2.900	2.9435	0.087	0.145	0.203
R5106N301x	2.970	3.000	3.030	2.9160	3.000	3.0450	0.090	0.150	0.210
R5106N311x	3.069	3.100	3.131	3.0132	3.100	3.1465	0.093	0.155	0.217
R5106N321x	3.168	3.200	3.232	3.1104	3.200	3.2480	0.096	0.160	0.224
R5106N331x	3.267	3.300	3.333	3.2076	3.300	3.3495	0.099	0.165	0.231
R5106N341x	3.366	3.400	3.434	3.3048	3.400	3.4510	0.102	0.170	0.238
R5106N351x	3.465	3.500	3.535	3.4020	3.500	3.5525	0.105	0.175	0.245
R5106N361x	3.564	3.600	3.636	3.4992	3.600	3.6540	0.108	0.180	0.252
R5106N371x	3.663	3.700	3.737	3.5964	3.700	3.7555	0.111	0.185	0.259
R5106N381x	3.762	3.800	3.838	3.6936	3.800	3.8570	0.114	0.190	0.266
R5106N391x	3.861	3.900	3.939	3.7908	3.900	3.9585	0.117	0.195	0.273
R5106N401x	3.960	4.000	4.040	3.8880	4.000	4.0600	0.120	0.200	0.280
R5106N411x	4.059	4.100	4.141	3.9852	4.100	4.1615	0.123	0.205	0.287
R5106N421x	4.158	4.200	4.242	4.0824	4.200	4.2630	0.126	0.210	0.294
R5106N431x	4.257	4.300	4.343	4.1796	4.300	4.3645	0.129	0.215	0.301
R5106N441x	4.356	4.400	4.444	4.2768	4.400	4.4660	0.132	0.220	0.308
R5106N451x	4.455	4.500	4.545	4.3740	4.500	4.5675	0.135	0.225	0.315
R5106N461x	4.554	4.600	4.646	4.4712	4.600	4.6690	0.138	0.230	0.322
R5106N471x	4.653	4.700	4.747	4.5684	4.700	4.7705	0.141	0.235	0.329
R5106N481x	4.752	4.800	4.848	4.6656	4.800	4.8720	0.144	0.240	0.336
R5106N491x	4.851	4.900	4.949	4.7628	4.900	4.9735	0.147	0.245	0.343
R5106N501x	4.950	5.000	5.050	4.8600	5.000	5.0750	0.150	0.250	0.350
R5106N511x	5.049	5.100	5.151	4.9572	5.100	5.1765	0.153	0.255	0.357
R5106N521x	5.148	5.200	5.252	5.0544	5.200	5.2780	0.156	0.260	0.364
R5106N531x	5.247	5.300	5.353	5.1516	5.300	5.3795	0.159	0.265	0.371
R5106N541x	5.346	5.400	5.454	5.2488	5.400	5.4810	0.162	0.270	0.378
R5106N551x	5.445	5.500	5.555	5.3460	5.500	5.5825	0.165	0.275	0.385

THEORY OF OPERATION

Timing Chart

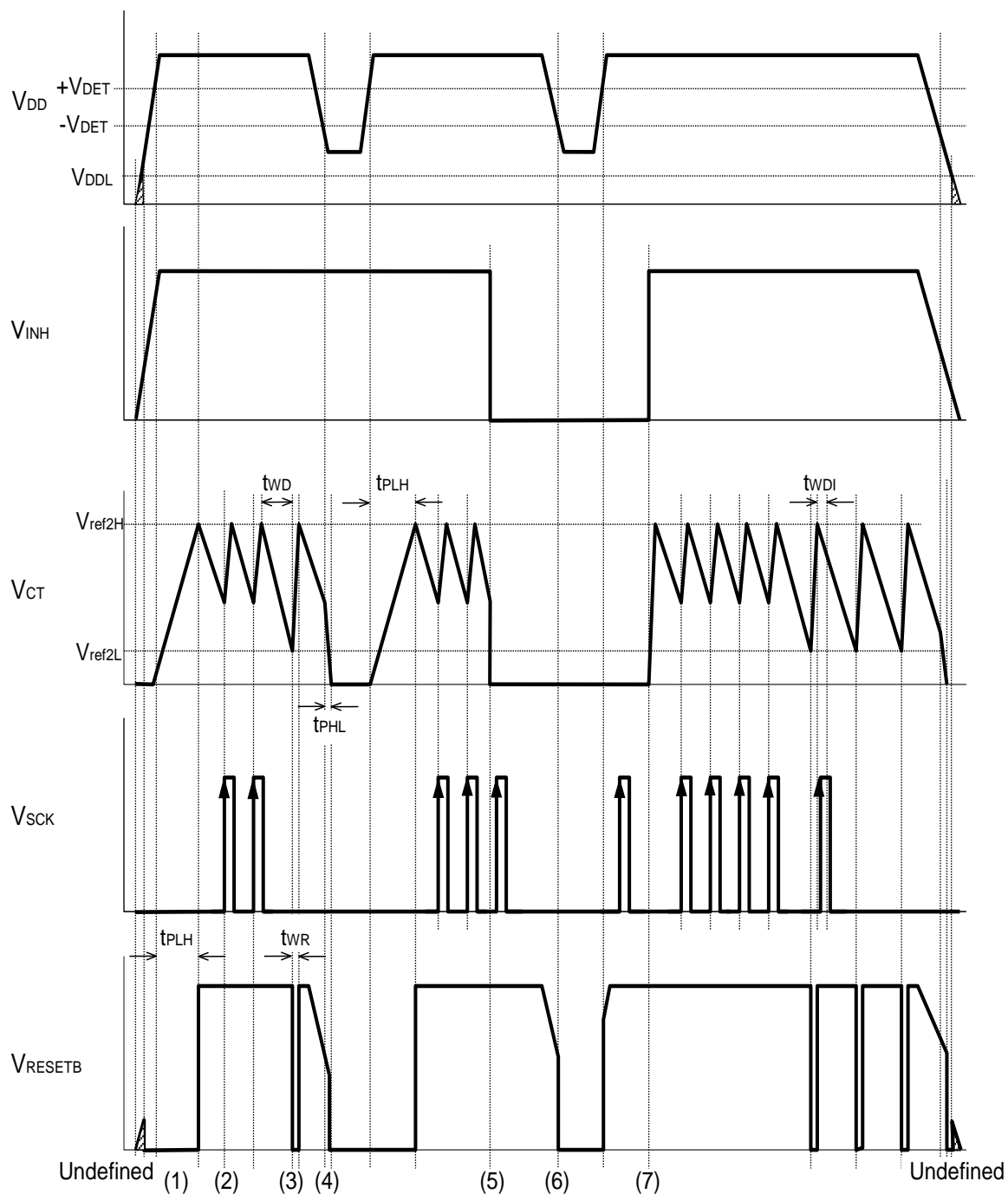

- *) V_{ref2H} : C_T pin voltage at the end of WDT timeout period.
- *) V_{ref2L} : C_T pin voltage at the begin of WDT timeout period.
- *) V_{DDL} : 0.9 V (Max.)

Operating Description

- (1) When the power supply, V_{DD} pin voltage becomes more than the released voltage ($+V_{DET}$), after the released delay time (or the power on reset time t_{PLH}), the output of RESETB becomes "H" level.
- (2) When the SCK pulse is input, the watchdog timer (WDT) is cleared, and C_T pin mode changes from the discharge mode to the charge mode. When the C_T pin voltage becomes higher than V_{ref2H} , the mode will change into the discharge mode, and next watchdog time count starts.
- (3) Unless the SCK pulse is input, WDT will not be cleared, and during the charging period of C_T pin, RESETB="L".
- (4) When the V_{DD} pin becomes lower than the detector threshold voltage ($-V_{DET}$), RESETB outputs "L".
- (5) If "L" signal is input to the INH pin, the RESETB outputs "H", regardless the SCK clock state.
- (6) During the "L" period of INH pin, the voltage detector monitors the supply voltage.
- (7) When the signal to the INH pin is set from "L" to "H", the watchdog starts supervising the system clock, or charge cycle to the C_T pin starts, the capacitor connected to the C_T pin is charged with the current of setting Reset time of WDT.

Watchdog Timeout period/Reset hold time

The watchdog timeout period and reset hold time can be set with an external capacitor to C_T pin.

The next equations describe the relation between the watchdog timeout period and the external capacitor value, or the reset hold time and the external capacitor value.

$$t_{WD} (s) = 3.1 \times 10^6 \times C (F)$$

$$t_{WR} (s) = t_{WD}/9$$

The watchdog timer (WDT) timeout period is determined with the discharge time of the external capacitor.

During the watchdog timeout period, if the clock pulse from the system is detected, WDT is cleared and the capacitor is charged. When the charge of the capacitor completes, another watchdog timeout period starts again. During the watchdog timeout period, if the clock pulse from the system is not detected, during the next reset hold time RESETB pin outputs "L".

During the reset time, (while charging the external capacitor) and after starting the watchdog timeout period, (just after from the discharge of the external capacitor) even if the clock pulse is input during the time period " t_{WDI} ", the clock pulse is ignored.

$$t_{WDI} (s) = t_{WD}/10$$

Released Delay Time (Power-on Reset delay time)

The released delay time can be set with an external capacitor connected to the C_T pin. The next equation describes the relation between the capacitance value and the released delay time (t_{PLH}).

$$t_{PLH} (s) = 3.7 \times 10^6 \times C (F)$$

The capacitor connected to C_T pin determines t_{WD} , t_{WR} , and t_{PLH} .

When the V_{DD} voltage becomes equal or less than ($-V_{DET}$), discharge of the capacitor connected to the C_T pin starts. Therefore, if the discharge is not enough and V_{DD} voltage returns to ($+V_{DET}$) or more, thereafter the delay time will be shorter than t_{PLH} which is expected.

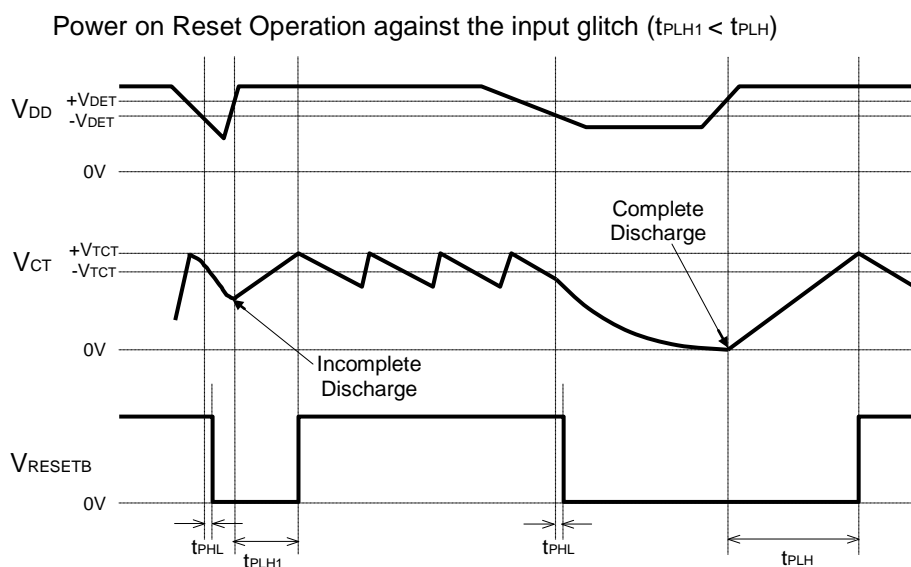

Minimum Operating Voltage

We specified the minimum operating voltage as the minimum input voltage in which the condition of RESETB pin being 0.1V or lower than 0.1V. (Herein, pull-up resistance is set as 100k Ω in the case of the Nch open-drain output type.)

Inhibit (INH) Function

If INH pin is set at "L", the watchdog timer stops monitoring the clock, and the RESETB output will be dominant by the voltage detector's operation. Therefore, if the supply voltage is set at more than the detector threshold level, RESETB outputs "H" regardless the clock pulse. INH pin is pulled up with a resistor (TYP.110k Ω) internally.

RESETB Output

RESETB pin's output type is selectable either the Nch open-drain output or CMOS output. If the Nch open-drain type output is selected, the RESETB pin is pulled up with an external resistor to an appropriate voltage source.

Clock Pulse Input

Built-in watchdog timer is cleared with the SCK clock pulse within the watchdog timeout period.

APPLICATION INFORMATION

Typical Applications

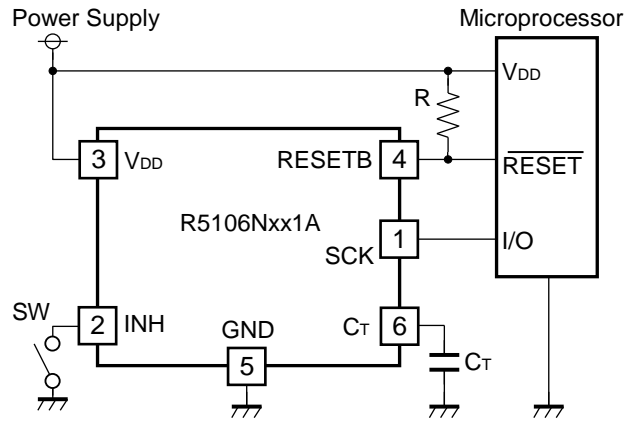

R5106Nxx1A

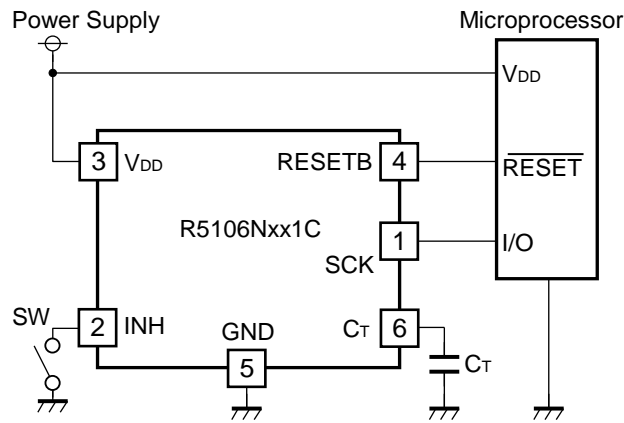

R5106Nxx1C

TECHNICAL NOTES

When connecting resistors to the device's input pin

When connecting a resistor (R1) to an input of this device, the input voltage decreases by [Device's Consumption Current] x [Resistance Value] only. And, the cross conduction current⁽¹⁾, which occurs when changing from the detecting state to the release state, is decreased the input voltage by [Cross Conduction Current] x [Resistance Value] only. And then, this device will enter the re-detecting state if the input voltage reduction is larger than the difference between the detector voltage and the released voltage.

When the input resistance value is large and the VDD is gone up at mildly in the vicinity of the released voltage, repeating the above operation may result in the occurrence of output.

As shown in Figure A/B, set R1 to become 100kΩ or less as a guide, and connect C_{IN}⁽²⁾ of 0.1μF and more to between the input pin and GND. Besides, make evaluations including temperature properties under the actual usage condition, with using the evaluation board like this way. As result, make sure that the cross conduction current has no problem.

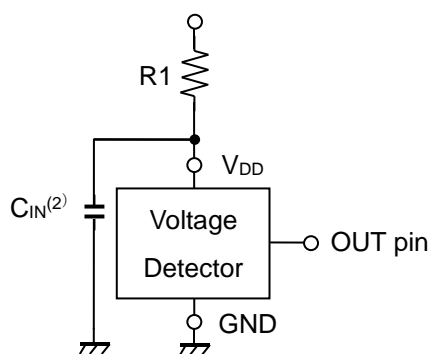

Figure A

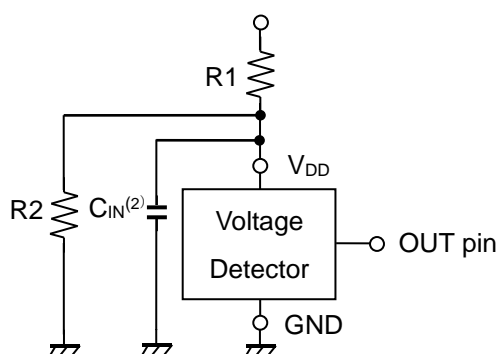

Figure B

⁽¹⁾ In the CMOS output type, a charging current for OUT pin is included.

⁽²⁾ Note the bias dependence of capacitors.

TYPICAL CHARACTERISTICS

Note: Typical Characteristics are intended to be used as reference data; they are not guaranteed.

1) Supply Current vs. Input Voltage

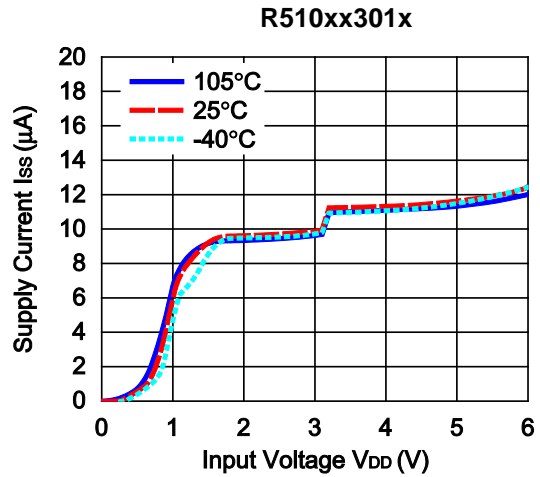
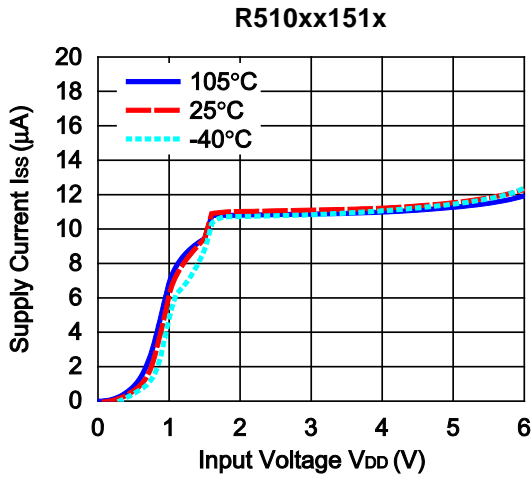

2) Detector Threshold vs. Temperature

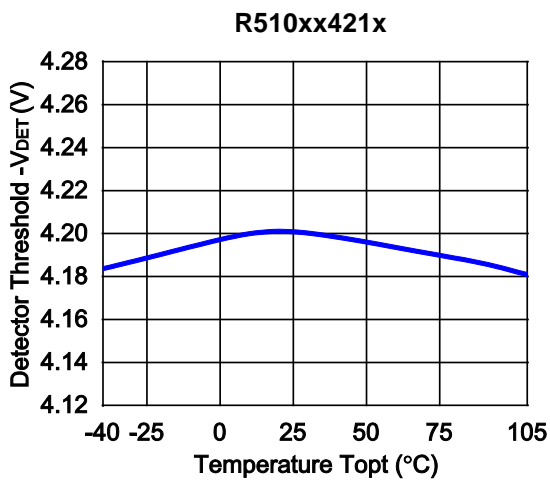
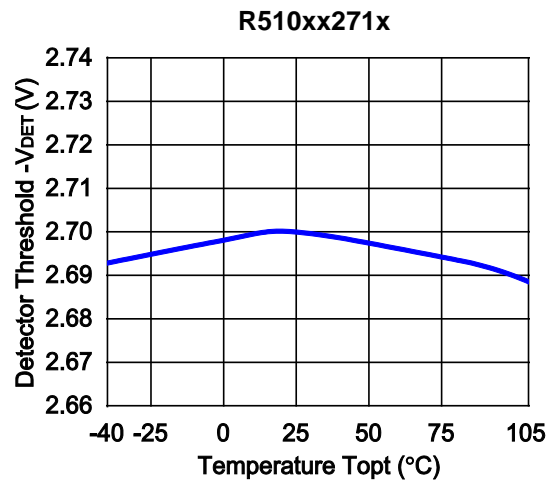
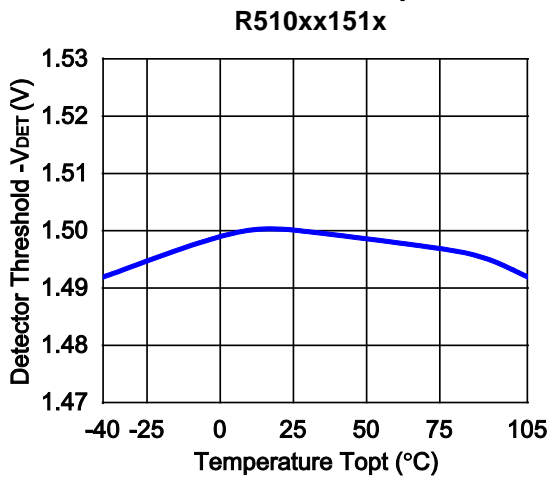

3) Detector Threshold Hysteresis vs. Temperature

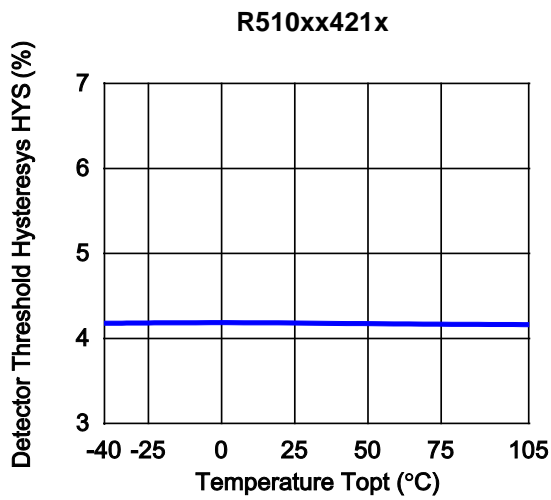
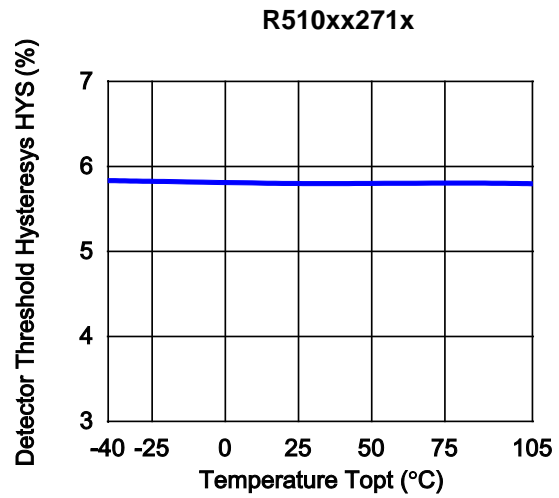
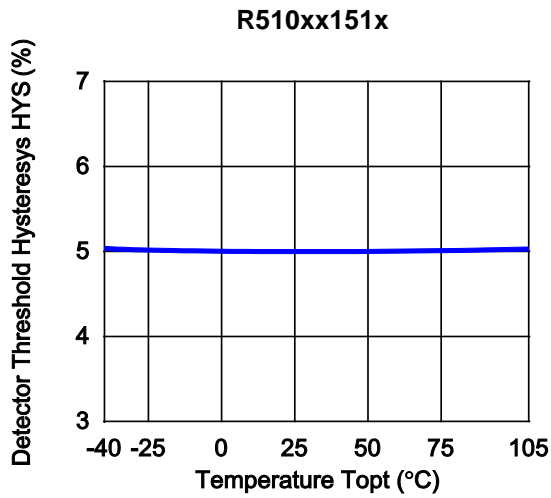

4) Nch Driver Output Current vs. V_{DS}

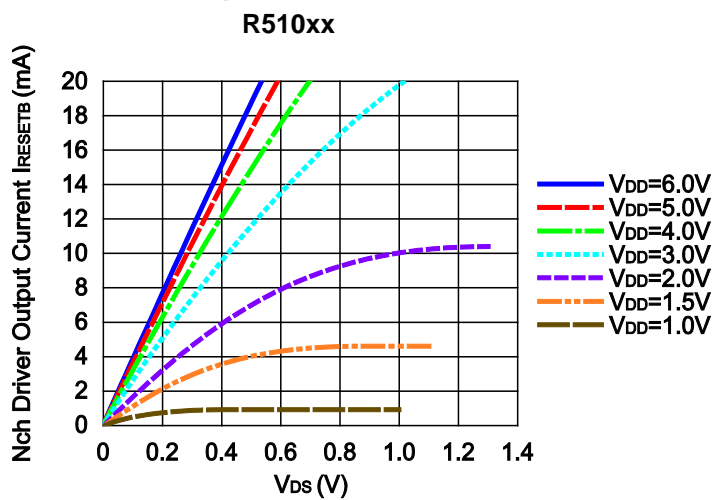

5) Nch Driver Output Current vs. Input Voltage

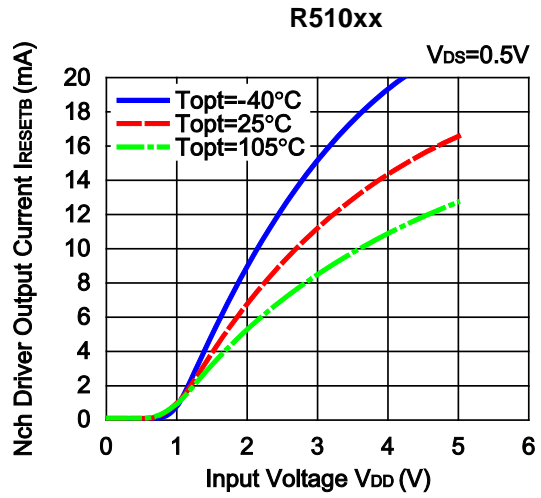
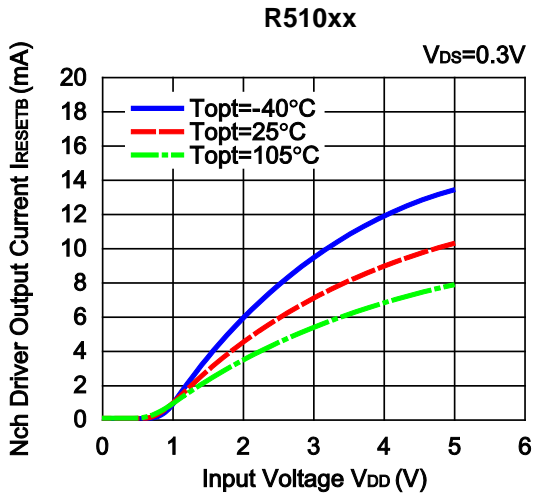

6) Pch Driver Output Current vs. Input Voltage

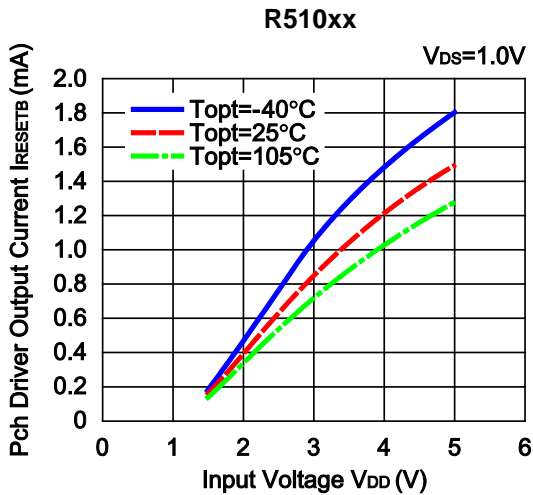
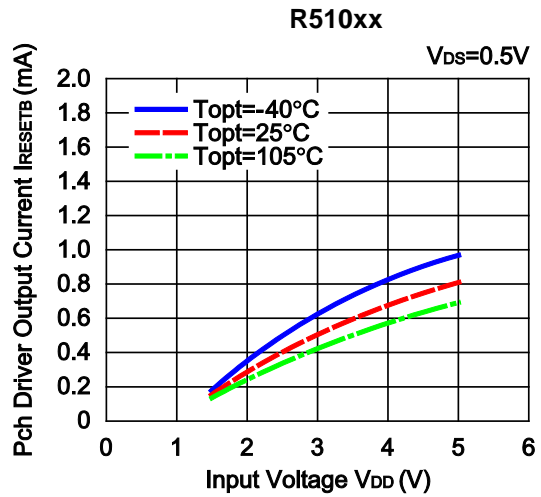
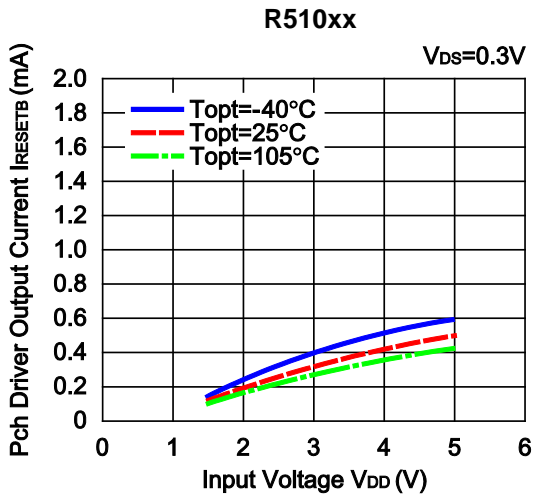

7) Released Delay Time vs. Input Voltage
R510xx

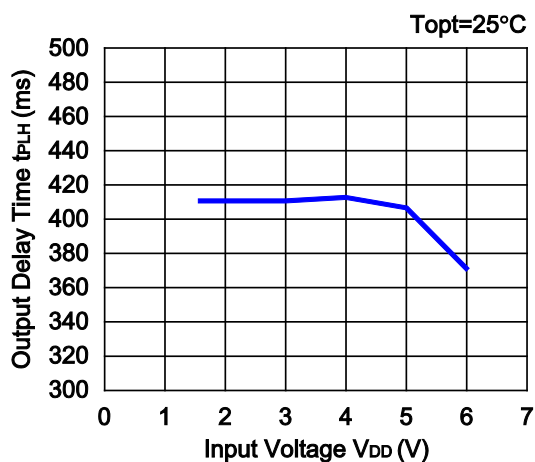

8) Released Delay Time vs. Temperature
R510xx

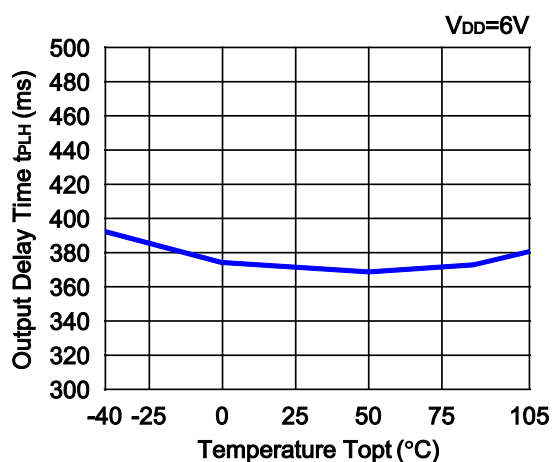

9) Detector Output Delay Time vs. Temperature
R510xx

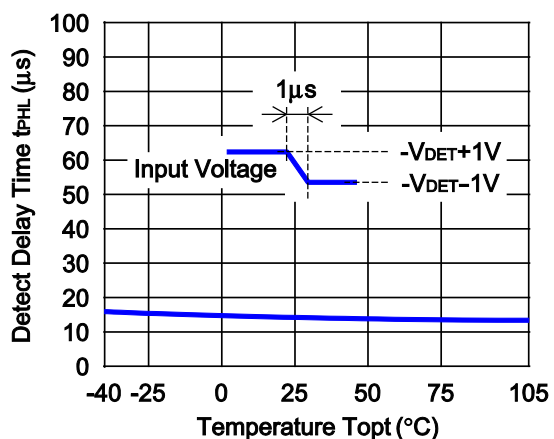

10) WDT Reset Timer vs. Temperature
R510xx

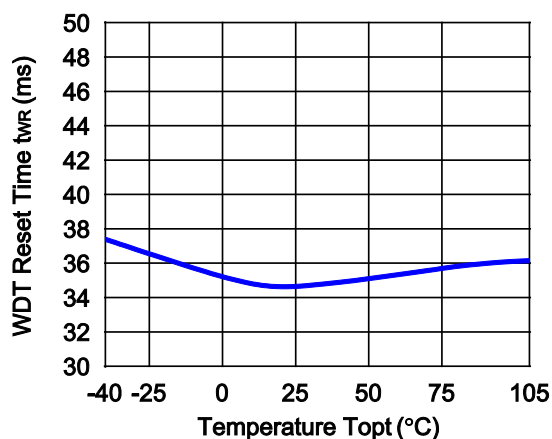

11) WDT Timeout Period vs. Temperature
R510xx

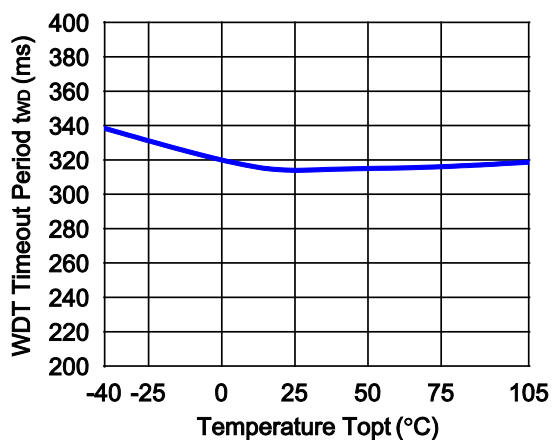

12) WDT Reset Timer vs. Input Voltage
R510xx

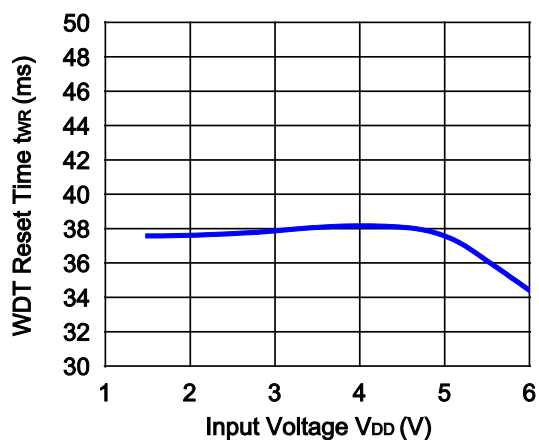

13) WDT Timeout Period vs. Input Voltage

14) Output Delay Time vs. External Capacitance

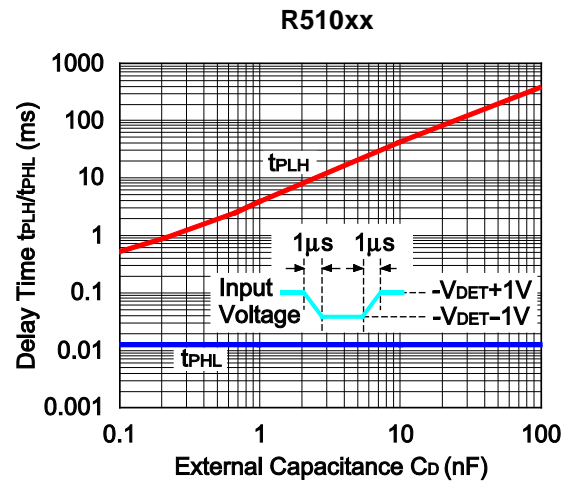
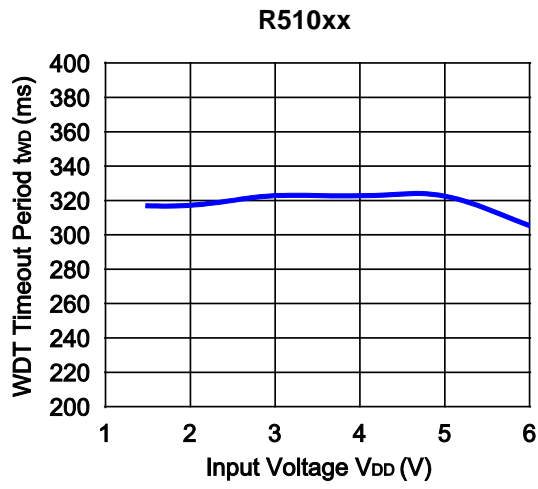

The power dissipation of the package is dependent on PCB material, layout, and environmental conditions. The following measurement conditions are based on JEDEC STD. 51-7.

Measurement Conditions

Item	Measurement Conditions
Environment	Mounting on Board (Wind Velocity = 0 m/s)
Board Material	Glass Cloth Epoxy Plastic (Four-Layer Board)
Board Dimensions	76.2 mm × 114.3 mm × 0.8 mm
Copper Ratio	Outer Layer (First Layer): Less than 95% of 50 mm Square Inner Layers (Second and Third Layers): Approx. 100% of 50 mm Square Outer Layer (Fourth Layer): Approx. 100% of 50 mm Square
Through-holes	φ 0.3 mm × 7 pcs

Measurement Result

(Ta = 25°C, Tjmax = 125°C)

Item	Measurement Result
Power Dissipation	660 mW
Thermal Resistance (θja)	θja = 150°C/W
Thermal Characterization Parameter (ψjt)	ψjt = 51°C/W

θja: Junction-to-Ambient Thermal Resistance

ψjt: Junction-to-Top Thermal Characterization Parameter

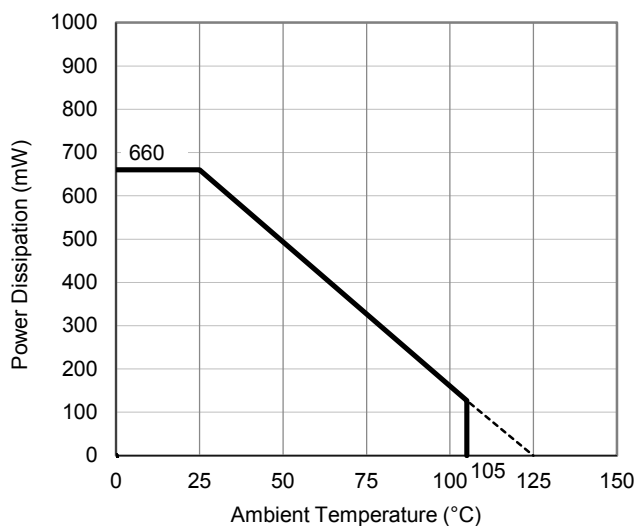

Power Dissipation vs. Ambient Temperature

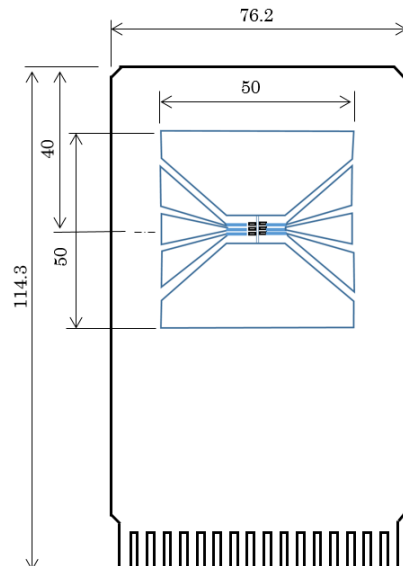

Measurement Board Pattern

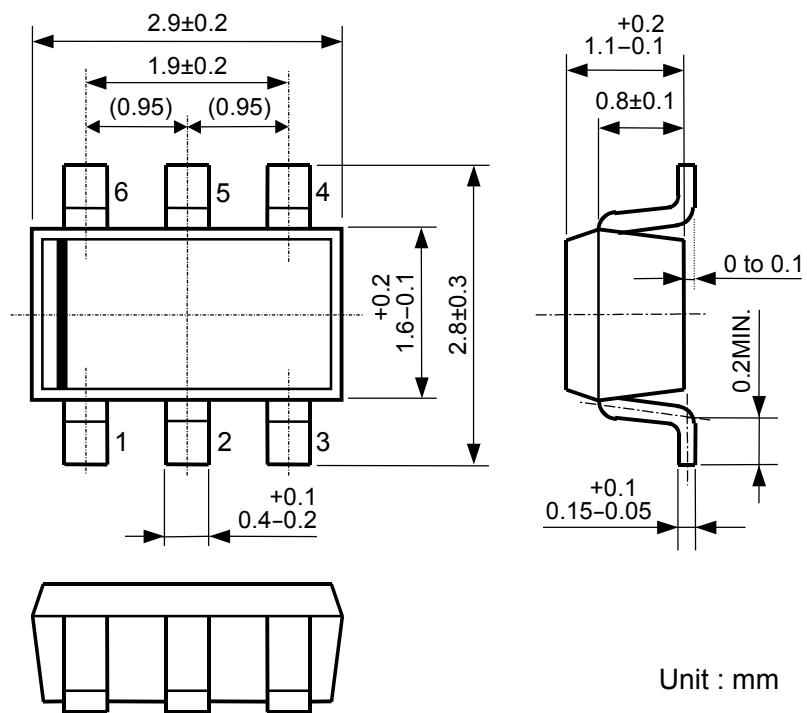

SOT-23-6 Package Dimensions (Unit: mm)



1. The products and the product specifications described in this document are subject to change or discontinuation of production without notice for reasons such as improvement. Therefore, before deciding to use the products, please refer to Ricoh sales representatives for the latest information thereon.
2. The materials in this document may not be copied or otherwise reproduced in whole or in part without prior written consent of Ricoh.
3. Please be sure to take any necessary formalities under relevant laws or regulations before exporting or otherwise taking out of your country the products or the technical information described herein.
4. The technical information described in this document shows typical characteristics of and example application circuits for the products. The release of such information is not to be construed as a warranty of or a grant of license under Ricoh's or any third party's intellectual property rights or any other rights.
5. The products listed in this document are intended and designed for use as general electronic components in standard applications (office equipment, telecommunication equipment, measuring instruments, consumer electronic products, amusement equipment etc.). Those customers intending to use a product in an application requiring extreme quality and reliability, for example, in a highly specific application where the failure or misoperation of the product could result in human injury or death (aircraft, spacevehicle, nuclear reactor control system, traffic control system, automotive and transportation equipment, combustion equipment, safety devices, life support system etc.) should first contact us.
6. We are making our continuous effort to improve the quality and reliability of our products, but semiconductor products are likely to fail with certain probability. In order to prevent any injury to persons or damages to property resulting from such failure, customers should be careful enough to incorporate safety measures in their design, such as redundancy feature, fire containment feature and fail-safe feature. We do not assume any liability or responsibility for any loss or damage arising from misuse or inappropriate use of the products.
7. Anti-radiation design is not implemented in the products described in this document.
8. The X-ray exposure can influence functions and characteristics of the products. Confirm the product functions and characteristics in the evaluation stage.
9. WLCSP products should be used in light shielded environments. The light exposure can influence functions and characteristics of the products under operation or storage.
10. There can be variation in the marking when different AOI (Automated Optical Inspection) equipment is used. In the case of recognizing the marking characteristic with AOI, please contact Ricoh sales or our distributor before attempting to use AOI.
11. Please contact Ricoh sales representatives should you have any questions or comments concerning the products or the technical information.



Ricoh is committed to reducing the environmental loading materials in electrical devices with a view to contributing to the protection of human health and the environment.

Ricoh has been providing RoHS compliant products since April 1, 2006 and Halogen-free products since April 1, 2012.

RICOH RICOH ELECTRONIC DEVICES CO., LTD.

Official website

<https://www.n-redc.co.jp/en/>

Contact us

<https://www.n-redc.co.jp/en/buy/>

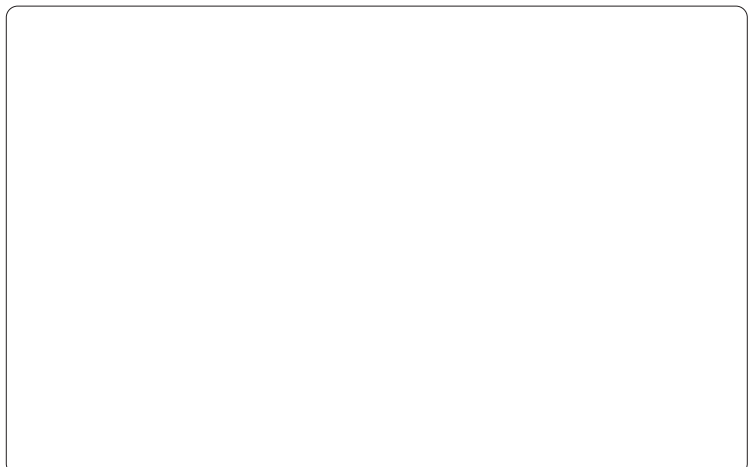

X-ON Electronics

Largest Supplier of Electrical and Electronic Components

Click to view similar products for [Supervisory Circuits](#) category:

Click to view products by [Nisshinbo](#) manufacturer:

Other Similar products are found below :

[CAT1161LI-25-G](#) [CAT853STBI-T3](#) [CAT1026LI-30-G](#) [CAT1320LI-25-G](#) [TC54VN2402EMB713](#) [MCP1316T-44NE/OT](#) [MCP1316MT-45GE/OT](#) [MCP1316MT-23LI/OT](#) [MAX8997EWW+](#) [MAX6725AKASYD3-LF-T](#) [DS1232L](#) [NCV302HSN45T1G](#) [PT7M6130NLTA3EX](#) [PT7M7811STBEX-2017](#) [S-1000N28-I4T1U](#) [CAT1161LI-28-G](#) [MCP1321T-29AE/OT](#) [MCP1319MT-47QE/OT](#) [S-1000N23-I4T1U](#) [S-1000N19-I4T1U](#) [CAT824UTDI-GT3](#) [TC54VC2502ECB713](#) [PT7M6133NLTA3EX](#) [PT7M6127NLTA3EX](#) [VDA2510NTA](#) [AP0809ES3-r](#) [HG811RM4/TR](#) [MD7030C](#) [MD7033C](#) [MD7019](#) [MD7020](#) [MD7021](#) [MD7023](#) [MD7024](#) [MD7027](#) [MD7030](#) [MD7033](#) [MD7035](#) [MD7036](#) [MD7039](#) [MD7040](#) [MD7044](#) [MD7050](#) [MD7015](#) [MD7028](#) [MD7031](#) [MD7042](#) [MD7043](#) [MD7047](#) [MD7060](#)