

## Li-Ion/Li-Polymer 1-Cell Protector

NO. EA-339-201211

### OUTLINE

The R5486K is an overcharge protection IC for Lithium-ion (Li+)/Lithium polymer secondary battery. This device can detect over-charge, over-discharge, excess discharge and excess charge current of one-cell Li-ion (Li+)/Li-ion polymer battery. The external resistor added to the RSENS pin can enhance a high precision overcurrent detection. The excess discharge current detection has two stages of detections to ensure the detection accuracy. The current consumption after the over-discharge detection is suppressed by stopping the internal circuits.

### FEATURES

- Absolute Maximum Rating..... 30 V
- Supply Current (Normal Mode)..... Typ. 4.0  $\mu$ A
- Supply Current (Standby Mode)..... Max. 0.1  $\mu$ A

#### Detector Thresholds Accuracy

- Over-charge Detector Threshold .....  $\pm 20$  mV ( $V_{DET1} \leq 4.5$  V)  
 $\pm 25$  mV ( $4.5$  V <  $V_{DET1}$ )
- Over-discharge Detector Threshold .....  $\pm 35$  mV
- Excess Discharge Current Threshold 1 ( $V_{DET31}$ ).....  $\pm 8\%$  ( $V_{DET31} \geq 0.038$  V)  
 $\pm 3.1$  mV ( $V_{DET31} < 0.038$  V) (Note1)
- Excess Discharge Current Threshold 2 ( $V_{DET32}$ ).....  $\pm 8\%$  ( $V_{DET32} \geq 0.038$  V)  
 $\pm 3.1$  mV ( $V_{DET32} < 0.038$  V) (Note2)
- Short Detector Threshold .....  $\pm 45$  mV
- Excess Charge Current Threshold .....  $\pm 15\%$  ( $V_{DET4} \leq -0.02$  V)  
 $\pm 3$  mV ( $V_{DET4} > -0.02$  V) (Note3)

(Note1)

$V_{DET31}$ Setting Range	Accuracy
0.015 V to 0.037 V	$\pm 3.1$ mV Equivalent Range: $\pm 8.4\%$ ( $V_{DET31} = 0.037$ V) to $\pm 20.6\%$ ( $V_{DET31} = 0.015$ V)

(Note2)

$V_{DET32}$ Setting Range	Accuracy
0.025 V to 0.037 V	$\pm 3.1$ mV Equivalent Range: $\pm 8.4\%$ ( $V_{DET32} = 0.037$ V) to $\pm 12.4\%$ ( $V_{DET32} = 0.025$ V)

(Note3)

$V_{DET4}$ Setting Range	Accuracy
-0.019 V to -0.015 V	$\pm 3.0$ mV Equivalent Range: $\pm 15.8\%$ ( $V_{DET4} = -0.019$ V) to $\pm 20\%$ ( $V_{DET4} = -0.015$ V)

**Detector Thresholds Range**

- Over-charge Detector Threshold .....4.1 V to 4.6 V, 0.005 V step
- Over-discharge Detector Threshold .....2.1 V to 3.0 V, 0.050 V step
- Short Detector Threshold .....0.15 V –0.30 V, 0.01 V step
- Excess Charge Current Threshold .....–0.060 V to –0.015 V, 0.001 V step
- Maximum Operating Voltage for Inhibition of Charger..... 0.7 V or 1.5 V

**Detector Thresholds Range (R5486KxxxCG)**

- Excess Discharge Current Threshold 1 ( $V_{DET31}$ ).....0.015 V to 0.046 V, 0.001 V step
- Excess Discharge Current Threshold 2 ( $V_{DET32}$ ).....0.030 V to 0.080 V, 0.001 V step <sup>(Note4)</sup>

(Note4)

$V_{DET31}$ Setting Range	$V_{DET32}$ Setting Range
$V_{DET31} \leq 0.030$ V	$V_{DET32} \geq V_{DET31} + 0.015$ V
$0.031$ V $\leq V_{DET31} \leq 0.035$	$V_{DET32} \geq 0.051$ V
$V_{DET31} \geq 0.036$ V	$V_{DET32} \geq V_{DET31} + 0.015$ V

**Detector Thresholds Range (R5486KxxxCM)**

- Excess Discharge Current Threshold 1 ( $V_{DET31}$ ).....disable
- Excess Discharge Current Threshold 2 ( $V_{DET32}$ ).....0.025 V to 0.080 V, 0.001 V step

**Output Delay Time**

- Over-charge Detector Output Delay ( $t_{VDET1}$ ).....1.0 s
- Over-discharge Detector Output Delay ( $t_{VDET2}$ ).....20 ms
- Excess Discharge Current Detector Output Delay 2 ( $t_{VDET32}$ ).....12 ms
- Excess Charge Current Detector Output Delay ( $t_{VDET4}$ ).....16 ms
- Short Detector Output Delay ( $t_{SHORT}$ ).....250  $\mu$ s

**Output Delay Time (R5486KxxxCG)**

- Excess Discharge Current Detector Output Delay 1 .....selectable from 3 s, 4 s or 5 s

**Functions**

- 0-V Battery Charge Option.....unacceptable
- Output Delay Time Shorting Function.....At COUT is "H", if V- level is set at –2.0 V, the output Delay time of detect the over-charge and over-discharge can be reduced. (Delay Time for over-charge becomes about 1/100 of normal state.)
- Release Over-charge Detector.....Latch-type
- Release Over-discharge Detector.....Latch-type
- Package.....DFN(PLP)1414-6

**APPLICATIONS**

- Li+/Li Polymer Protector of Over-charge, Over-discharge, Excess-current for Battery Pack
- High Precision Protectors for Smartphones and Electronic Gadgets using On-board Li+/Li Polymer Battery

## SELECTION GUIDE

The input threshold of over-charge, over-discharge and excess discharge current are user-selectable options.

### Selection Guide

Product Name	Package	Quantity per Reel	Pb Free	Halogen Free
R5486Kxxx\$*-TR	DFN(PLP)1414-6	5,000 pcs	Yes	Yes

xxx: Set Output Voltage Code

Refer to *R5486K Code List*.

\$: Delay Time Version

Version	t <sub>VDET1</sub> [s]	t <sub>VDET2</sub> [ms]	t <sub>VDET31</sub> [ms]	t <sub>VDET32</sub> [ms]	t <sub>VDET4</sub> [ms]	t <sub>SHORT</sub> [μs]
C	1	20	*	12	16	250

\*Refer to *R5486K Code List*.

\*: Function Version

Version	Return from Over-Charge	Return from Over-Discharge	V <sub>DET31</sub>	0-V Charge
G	Latch-type	Latch-type	Enable	NG
M	Latch-type	Latch-type	Disable	NG

## Product Code List

## R5486KxxxCG Code List

Code	Set Output Voltage [V]							DelayTime [s]
	V <sub>DET1</sub>	V <sub>DET2</sub>	V <sub>DET31</sub>	V <sub>DET32</sub>	V <sub>DET4</sub>	V <sub>SHORT</sub>	V <sub>NOCHG</sub>	t <sub>vDET31</sub>
<b>R5486KxxxCG:</b>								
R5486K101CG	4.425	2.400	0.015	0.030	-0.015	0.150	1.500	5.0
R5486K102CG	4.200	2.500	0.026	0.051	-0.046	0.150	0.700	3.0
R5486K103CG	4.280	2.600	0.030	0.045	-0.025	0.150	1.500	5.0
R5486K104CG	4.425	2.600	0.030	0.045	-0.025	0.150	1.500	5.0
R5486K105CG	4.425	2.400	0.037	0.052	-0.037	0.250	1.500	3.0
R5486K106CG	4.425	2.400	0.040	0.072	-0.022	0.250	1.500	3.0
R5486K107CG	4.425	2.400	0.040	0.072	-0.022	0.180	0.700	3.0
R5486K108CG	4.390	2.800	0.026	0.051	-0.042	0.150	0.700	5.0
R5486K109CG	4.400	2.600	0.025	0.040	-0.015	0.150	1.500	3.0
R5486K110CG	4.500	2.300	0.035	0.051	-0.043	0.250	0.700	3.0
R5486K111CG	4.450	2.600	0.033	0.055	-0.030	0.250	0.700	4.0
R5486K112CG	4.400	3.000	0.025	0.040	-0.015	0.150	1.500	3.0
R5486K113CG	4.275	2.350	0.030	0.045	-0.020	0.150	0.700	5.0
R5486K114CG	4.425	2.400	0.037	0.052	-0.033	0.250	1.500	3.0
R5486K115CG	4.280	2.900	0.030	0.045	-0.025	0.150	1.500	5.0
R5486K116CG	4.475	2.600	0.035	0.051	-0.031	0.150	0.700	3.0
R5486K117CG	4.230	2.900	0.015	0.030	-0.015	0.150	1.500	3.0
R5486K118CG	4.250	2.900	0.015	0.030	-0.015	0.150	1.500	3.0
R5486K119CG	4.470	2.300	0.037	0.054	-0.021	0.150	0.700	5.0
R5486K120CG	4.275	2.900	0.030	0.045	-0.020	0.150	0.700	5.0
R5486K121CG	4.275	2.800	0.030	0.045	-0.020	0.150	0.700	5.0
R5486K122CG	4.420	2.900	0.015	0.030	-0.015	0.150	1.500	3.0
R5486K123CG	4.280	3.000	0.015	0.030	-0.018	0.150	1.500	3.0
<b>R5486KxxxCM:</b>								
R5486K501CM	4.425	2.400	-	0.040	-0.022	0.300	1.500	-
R5486K502CM	4.425	2.600	-	0.052	-0.022	0.150	1.500	-
R5486K503CM	4.475	2.600	-	0.040	-0.025	0.250	0.700	-
R5486K504CM	4.425	2.400	-	0.040	-0.025	0.180	0.700	-
R5486K505CM	4.425	2.800	-	0.040	-0.030	0.150	1.500	-
R5486K506CM	4.425	2.600	-	0.030	-0.031	0.180	1.500	-
R5486K507CM	4.280	2.800	-	0.040	-0.030	0.150	1.500	-

## R5486KxxxCM Code List (Continued)

Code	Set Output Voltage [V]							DelayTime [s]
	V <sub>DET1</sub>	V <sub>DET2</sub>	V <sub>DET31</sub>	V <sub>DET32</sub>	V <sub>DET4</sub>	V <sub>SHORT</sub>	V <sub>NOCHG</sub>	t <sub>vDET31</sub>
R5486K508CM	4.230	2.800	-	0.050	-0.030	0.150	1.500	-
R5486K509CM	4.425	2.800	-	0.050	-0.030	0.150	1.500	-
R5486K510CM	4.280	2.800	-	0.050	-0.030	0.150	1.500	-
R5486K511CM	4.280	2.400	-	0.033	-0.024	0.150	1.500	-
R5486K512CM	4.405	2.800	-	0.040	-0.030	0.150	1.500	-
R5486K513CM	4.405	2.400	-	0.033	-0.024	0.150	1.500	-
R5486K514CM	4.450	2.600	-	0.040	-0.030	0.150	1.500	-
R5486K515CM	4.280	2.400	-	0.040	-0.030	0.150	1.500	-
R5486K516CM	4.425	2.800	-	0.050	-0.055	0.250	1.500	-
R5486K517CM	4.425	2.800	-	0.065	-0.060	0.180	1.500	-
R5486K518CM	4.425	2.400	-	0.034	-0.023	0.180	0.700	-
R5486K519CM	4.475	2.400	-	0.040	-0.025	0.180	0.700	-
R5486K520CM	4.425	2.400	-	0.030	-0.060	0.180	0.700	-
R5486K521CM	4.420	2.500	-	0.035	-0.030	0.150	0.700	-
R5486K522CM	4.475	2.400	-	0.042	-0.025	0.180	0.700	-
R5486K523CM	4.420	2.500	-	0.028	-0.025	0.150	0.700	-
R5486K524CM	4.425	2.800	-	0.026	-0.026	0.150	1.500	-
R5486K525CM	4.475	2.800	-	0.040	-0.025	0.180	0.700	-
R5486K526CM	4.475	2.600	-	0.040	-0.025	0.180	0.700	-
R5486K527CM	4.475	2.800	-	0.025	-0.021	0.150	1.500	-
R5486K528CM	4.475	2.500	-	0.045	-0.035	0.150	0.700	-
R5486K529CM	4.475	2.500	-	0.045	-0.036	0.150	0.700	-
R5486K530CM	4.475	2.600	-	0.046	-0.031	0.150	0.700	-
R5486K531CM	4.230	2.800	-	0.035	-0.018	0.150	1.500	-
R5486K532CM	4.230	2.600	-	0.035	-0.018	0.150	1.500	-
R5486K533CM	4.230	2.800	-	0.045	-0.015	0.150	1.500	-
R5486K534CM	4.230	2.600	-	0.045	-0.015	0.150	1.500	-
R5486K536CM	4.500	2.900	-	0.025	-0.023	0.150	1.500	-
R5486K537CM	4.550	2.600	-	0.040	-0.040	0.180	0.700	-
R5486K538CM	4.550	2.600	-	0.045	-0.040	0.180	0.700	-
R5486K539CM	4.480	2.800	-	0.040	-0.025	0.150	1.500	-
R5486K540CM	4.600	2.500	-	0.050	-0.057	0.250	0.700	-
R5486K541CM	4.550	2.600	-	0.055	-0.040	0.150	0.700	-
R5486K542CM	4.600	2.500	-	0.060	-0.057	0.180	0.700	-

**BLOCK DIAGRAM**

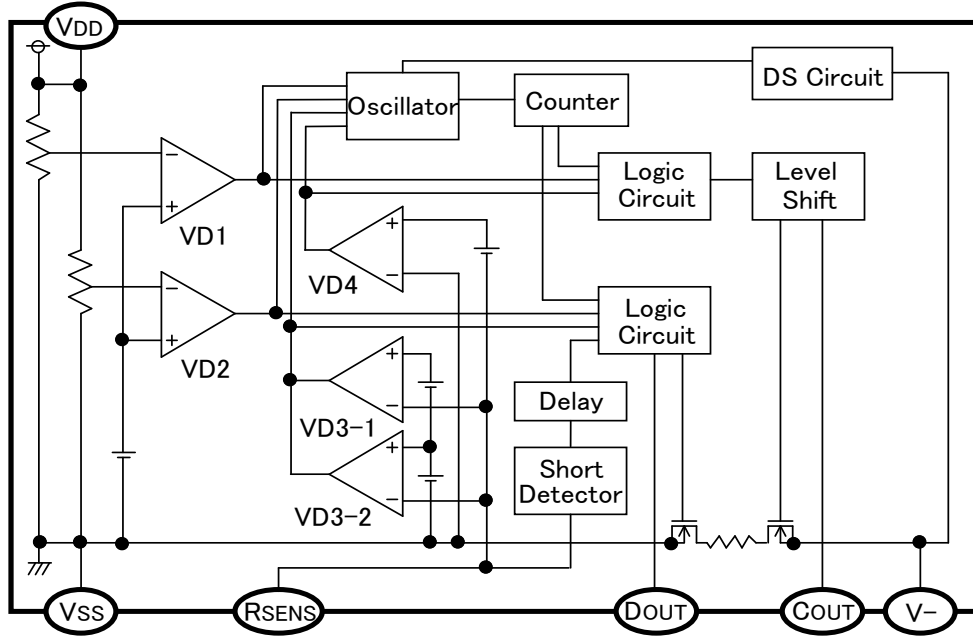

**R5486KxxxCG Block Diagram**

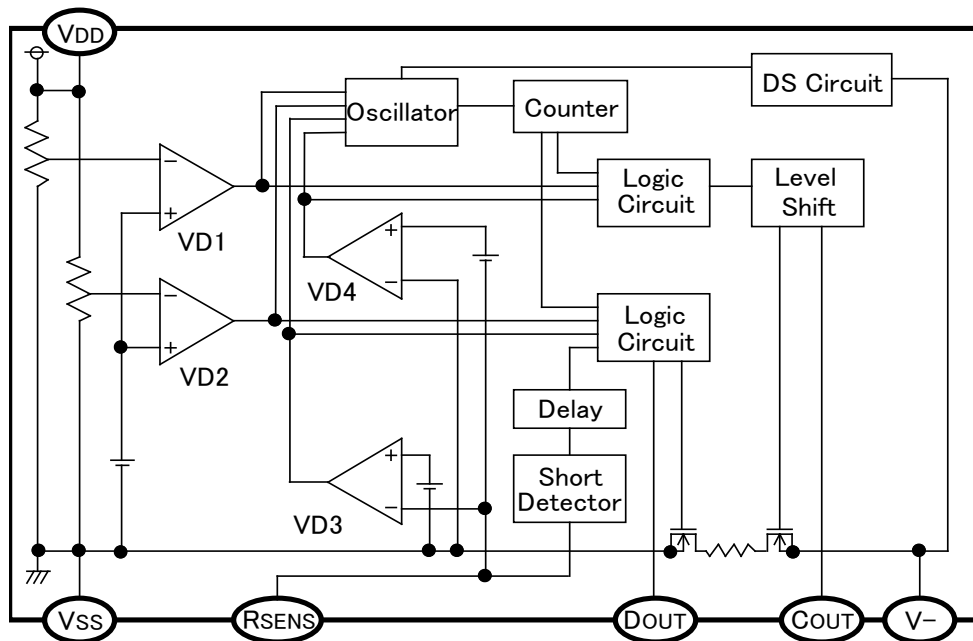

**R5486KxxxCM Block Diagram**

## PIN DESCRIPTION

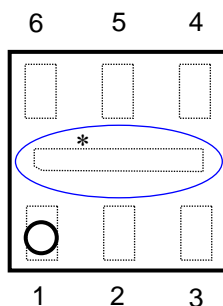

**R5486K (DFN(PLP)1414-6) Pin Configuration**

\* The tab is VDD level. Do not connect other wires or lad patterns.

### R5486K Pin Description

Pin No.	Symbol	Description
1	VSS	VSS pin. Ground pin for the IC
2	VDD	Power supply pin, the substrate voltage level of the IC.
3	RSENS	Input of overcurrent detection
4	V-	Pin for charger negative input
5	COUT	Output of over-charge detection, CMOS output
6	DOUT	Output of over-discharge detection, CMOS output

## ABSOLUTE MAXIMUM RATINGS

### Absolute Maximum Ratings

(Ta = 25°C, V<sub>SS</sub> = 0 V)

Symbol	Parameter	Ratings	Unit
V <sub>DD</sub>	Supply Voltage	-0.3 to 12	V
V <sub>-</sub>	V <sub>-</sub> Pin Input Voltage	V <sub>DD</sub> -30 to V <sub>DD</sub> +0.3	V
V <sub>RSENS</sub>	RSENS Pin Input Voltage	V <sub>SS</sub> -0.3 to V <sub>DD</sub> +0.3	V
V <sub>COU</sub>	COU Pin Output Voltage	V <sub>DD</sub> -30 to V <sub>DD</sub> +0.3	V
V <sub>DOU</sub>	DOU Pin Output Voltage	V <sub>SS</sub> -0.3 to V <sub>DD</sub> +0.3	V
P <sub>D</sub>	Power Dissipation	150	mW
T <sub>j</sub>	Junction Temperature Range	-40 to 125	°C
T <sub>stg</sub>	Storage Temperature Range	-55 to 125	°C

### ABSOLUTE MAXIMUM RATINGS

Electronic and mechanical stress momentarily exceeded absolute maximum ratings may cause permanent damage and may degrade the lifetime and safety for both device and system using the device in the field. The functional operation at or over these absolute maximum ratings is not assured.

## RECOMMENDED OPERATING CONDITIONS

### Recommended Operating Conditions

Symbol	Parameter	Rating	Unit
V <sub>DD1</sub>	Operating Input Voltage	1.5 to 5.0	V
T <sub>a</sub>	Operating Temperature Range	-40 to 85	°C

### RECOMMENDED OPERATING CONDITIONS

All of electronic equipment should be designed that the mounted semiconductor devices operate within the recommended operating conditions. The semiconductor devices cannot operate normally over the recommended operating conditions, even if they are used over such conditions by momentary electronic noise or surge. And the semiconductor devices may receive serious damage when they continue to operate over the recommended operating conditions.



## ELECTRICAL CHARACTERISTICS

## R5486K Electrical Characteristics

(Ta = 25°C)

Symbol	Parameter	Conditions	Min.	Typ.	Max.	Unit	Circuit (1)
V <sub>NOCHG</sub>	Maximum Operating Voltage for Inhibition of Charger	Voltage Defined as V <sub>DD</sub> - V <sub>SS</sub> , V <sub>DD</sub> - V <sub>-</sub> = 4 V	V <sub>NOCHG</sub> -0.3	V <sub>NOCHG</sub>	V <sub>NOCHG</sub> +0.3	V	A
V <sub>DET1</sub>	Overcharge Threshold Voltage	R1 = 330 Ω	V <sub>DET1</sub> ≤ 4.5 V	V <sub>DET1</sub>	V <sub>DET1</sub> -0.020	V	B
			V <sub>DET1</sub> > 4.5 V		V <sub>DET1</sub> -0.025		
t <sub>VD1</sub>	Output Delay of Overcharge	V <sub>DD</sub> = 3.6 V → V <sub>DET1</sub> + 0.05 V	0.7	1.0	1.3	s	B
t <sub>VREL1</sub>	Release Delay for VD1	V <sub>DD</sub> = 3.9 V, V <sub>-</sub> = 0 V → 1 V	11	16	21	ms	C
V <sub>DET2</sub>	Overdischarge Threshold	Detect falling edge of supply voltage	V <sub>DET2</sub> -0.035	V <sub>DET2</sub>	V <sub>DET2</sub> +0.035	V	D
t <sub>VD2</sub>	Output Delay of Overdischarge	V <sub>DD</sub> = V <sub>DET2</sub> + 0.13 V → V <sub>DET2</sub> - 0.08 V	14	20	26	ms	D
t <sub>VREL2</sub>	Release Delay for VD2	V <sub>DD</sub> = 1.9 V → V <sub>DET2</sub> + 0.08 V	0.7	1.2	1.7	ms	E
V <sub>DET31</sub>	Excess Discharge-current Threshold	Detect rising edge of RSENS pin voltage	V <sub>DET31</sub> < 0.038V	V <sub>DET31</sub>	V <sub>DET31</sub> -0.0031	V	F
			V <sub>DET31</sub> ≥ 0.038V		V <sub>DET31</sub> ×0.92		
t <sub>VD31</sub>	Output Delay of Excess Discharge-current 1	V <sub>DD</sub> = 3.0 V, V <sub>RSENS</sub> = 0 V to V <sub>DET31</sub> × 1.18 V <sub>-</sub> = V <sub>RSENS</sub>	t <sub>VD31</sub> ×0.7	t <sub>VD31</sub>	t <sub>VD31</sub> ×1.3	s	F
V <sub>DET32</sub>	Excess Discharge-current Threshold	Detect rising edge of RSENS pin voltage, V <sub>-</sub> = 0 V	V <sub>DET32</sub> < 0.038V	V <sub>DET32</sub>	V <sub>DET32</sub> -0.0031	V	F
			V <sub>DET32</sub> ≥ 0.038V		V <sub>DET32</sub> ×0.92		
t <sub>VD32</sub>	Output Delay of Excess Discharge-current 2	V <sub>DD</sub> = 3.0 V, V <sub>RSENS</sub> = 0 V to 0.1 V, V <sub>-</sub> = V <sub>RSENS</sub>	8	12	16	ms	F
t <sub>VREL3</sub>	Output Delay of Release from Excess Discharge-current	V <sub>DD</sub> = 3.1 V, V <sub>-</sub> = 3.1 V to 0 V V <sub>-</sub> = V <sub>RSENS</sub>	0.7	1.2	1.7	ms	F
V <sub>SHORT</sub>	Short Protection Voltage	V <sub>DD</sub> = 3.1 V, V <sub>RSENS</sub> = V <sub>-</sub>	V <sub>SHORT</sub> -0.045	V <sub>SHORT</sub>	V <sub>SHORT</sub> +0.045	V	F
t <sub>SHORT</sub>	Delay Time for Short Protection <sup>(2)</sup>	V <sub>DD</sub> = 3.1 V, V <sub>RSENS</sub> = 0 V to 3.1 V, V <sub>-</sub> = V <sub>RSENS</sub>	180	250	425	μs	F
R <sub>SHORT</sub>	Reset Resistance for Excess Current Protection	V <sub>DD</sub> = 3.6 V, V <sub>-</sub> = 1.0 V	20	45	70	kΩ	F
V <sub>DET4</sub>	Excess Chargecurrent Threshold	Detect falling edge of RSENS pin voltage, V <sub>-</sub> = 0 V	V <sub>DET4</sub> > -0.02V	V <sub>DET4</sub>	V <sub>DET4</sub> -0.003	V	G
			V <sub>DET4</sub> ≤ -0.02V		V <sub>DET4</sub> ×1.15		

(1) Refer to TEST CIRCUITS for detail information.

(2) Output Delay Time for Release from Short Protection is the same value as t<sub>VREL3</sub>.

## R5486K Electrical Characteristics (Continued)

(Ta = 25°C)

Symbol	Parameter	Conditions	Min.	Typ.	Max.	Unit	Circuit (1)
t <sub>VDET4</sub>	Output Delay of Excess Charge-current	V <sub>DD</sub> = 3.1 V, V <sub>RSENS</sub> = 0 V to -0.5 V, V <sub>-</sub> = V <sub>RSENS</sub>	11	16	21	ms	G
t <sub>VREL4</sub>	Output Delay of Release from Excess Charge-current	V <sub>DD</sub> = 3.1 V, V <sub>-</sub> = -0.5 V to 0 V, V <sub>-</sub> = V <sub>RSENS</sub>	0.7	1.2	1.7	ms	G
V <sub>DS</sub>	Delay Time Shortening Mode Voltage	V <sub>DD</sub> = 3.6 V	-2.6	-2.0	-1.4	V	G
V <sub>OL1</sub>	Nch ON-Voltage of C <sub>OUT</sub>	I <sub>ol</sub> = 50 μA, V <sub>DD</sub> = 4.55 V		0.4	0.5	V	H
V <sub>OH1</sub>	Pch ON-Voltage of C <sub>OUT</sub>	I <sub>oh</sub> = -50 μA, V <sub>DD</sub> = 3.9 V	3.4	3.7		V	I
V <sub>OL2</sub>	Nch ON-Voltage of D <sub>OUT</sub>	I <sub>ol</sub> = 50 μA, V <sub>DD</sub> = 1.9 V		0.2	0.5	V	J
V <sub>OH2</sub>	Pch ON-Voltage of D <sub>OUT</sub>	I <sub>oh</sub> = -50 μA, V <sub>DD</sub> = 3.9 V	3.4	3.7		V	K
I <sub>DD</sub>	Supply Current	V <sub>DD</sub> = 3.9 V, V <sub>-</sub> = 0 V		4.0	8.0	μA	L
I <sub>standby</sub>	Standby Current	V <sub>DD</sub> = 2.0 V			0.1	μA	L

(1) Refer to TEST CIRCUITS for detail information.

## R5486K Electrical Characteristics

(-20°C &lt; Ta &lt; 60°C)

Symbol	Parameter	Conditions	Min.	Typ.	Max.	Unit	Circuit (1)
V <sub>NOCHG</sub>	Maximum Operating Voltage for Inhibition of Charger	Voltage Defined as V <sub>DD</sub> - V <sub>SS</sub> , V <sub>DD</sub> - V <sub>-</sub> = 4 V	V <sub>NOCHG</sub> -0.43	V <sub>NOCHG</sub>	V <sub>NOCHG</sub> +0.4	V	A
V <sub>DET1</sub>	Over-charge Threshold Voltage	R1 = 330 Ω V <sub>DET1</sub> ≤ 4.5 V V <sub>DET1</sub> > 4.5 V	V <sub>DET1</sub> -0.025 V <sub>DET1</sub> -0.030	V <sub>DET1</sub>	V <sub>DET1</sub> +0.025 V <sub>DET1</sub> +0.030	V	B
t <sub>VDET1</sub>	Output Delay of Over-charge	V <sub>DD</sub> = 3.6 V → V <sub>DET1</sub> + 0.05V	0.67	1.0	1.48	s	B
t <sub>VREL1</sub>	Release Delay for VD1	V <sub>DD</sub> = 3.9 V, V <sub>-</sub> = 0 V → 1 V	10.2	16	24.4	ms	C
V <sub>DET2</sub>	Over-discharge Threshold	Detect falling edge of supply voltage	V <sub>DET2</sub> -0.040	V <sub>DET2</sub>	V <sub>DET2</sub> +0.040	V	D
t <sub>VDET2</sub>	Output Delay of Over-discharge	V <sub>DD</sub> = V <sub>DET2</sub> + 0.13 V → V <sub>DET2</sub> - 0.08 V	13.1	20	30	ms	D
t <sub>VREL2</sub>	Release Delay for VD2	V <sub>DD</sub> = 1.9 V → V <sub>DET2</sub> + 0.08V	0.65	1.2	1.93	ms	E
V <sub>DET31</sub>	Excess Discharge-current Threshold	Detect rising edge of RSENS pin voltage V <sub>DET31</sub> < 0.038V V <sub>DET31</sub> ≥ 0.038V	V <sub>DET31</sub> -0.0042 V <sub>DET31</sub> ×0.89	V <sub>DET31</sub>	V <sub>DET31</sub> +0.0042 V <sub>DET31</sub> ×1.11	V	F
t <sub>VDET31</sub>	Output Delay of Excess Discharge-current 1	V <sub>DD</sub> = 3.0 V, V <sub>RSENS</sub> = 0 V to V <sub>DET31</sub> × 1.18 V <sub>-</sub> = V <sub>RSENS</sub>	t <sub>VDET31</sub> ×0.66	t <sub>VDET31</sub>	t <sub>VDET31</sub> ×1.47	s	F
V <sub>DET32</sub>	Excess Discharge-current Threshold	Detect rising edge of RSENS pin voltage, V <sub>-</sub> = 0 V V <sub>DET32</sub> < 0.038V V <sub>DET32</sub> ≥ 0.038V	V <sub>DET32</sub> -0.0042 V <sub>DET32</sub> ×0.89	V <sub>DET32</sub>	V <sub>DET32</sub> +0.0042 V <sub>DET32</sub> ×1.11	V	F
t <sub>VDET32</sub>	Output Delay of Excess Discharge-current 2	V <sub>DD</sub> = 3.0 V, V <sub>RSENS</sub> = 0 V to 0.1 V, V <sub>-</sub> = V <sub>RSENS</sub>	7.4	12	18.5	ms	F
t <sub>VREL3</sub>	Output Delay of Release from Excess Discharge-current	V <sub>DD</sub> = 3.1 V, V <sub>-</sub> = 3.1 V to 0 V V <sub>-</sub> = V <sub>RSENS</sub>	0.65	1.2	1.9	ms	F
V <sub>SHORT</sub>	Short Protection Voltage	V <sub>DD</sub> = 3.1 V, V <sub>RSENS</sub> = V <sub>-</sub>	V <sub>SHORT</sub> -0.050	V <sub>SHORT</sub>	V <sub>SHORT</sub> +0.050	V	F
t <sub>SHORT</sub>	Delay Time for Short Protection <sup>(2)</sup>	V <sub>DD</sub> = 3.1V, V <sub>RSENS</sub> = 0V to 3.1V, V <sub>-</sub> = V <sub>RSENS</sub>	160	250	490	μs	F
R <sub>SHORT</sub>	Reset Resistance for Excess Current Protection	V <sub>DD</sub> = 3.6 V, V <sub>-</sub> = 1.0 V	17.1	45	71	kΩ	F
V <sub>DET4</sub>	Excess Charge-current Threshold	Detect falling edge of RSENS pin voltage, V <sub>-</sub> = 0 V V <sub>DET4</sub> > -0.02V V <sub>DET4</sub> ≤ -0.02V	V <sub>DET4</sub> -0.0040 V <sub>DET4</sub> ×1.17	V <sub>DET4</sub>	V <sub>DET4</sub> +0.0040 V <sub>DET4</sub> ×0.83	V	G

(1) Refer to TEST CIRCUITS for detail information.

(2) Output Delay Time for Release from Short Protection is the same value as t<sub>VREL3</sub>.

## R5486K Electrical Characteristics (Continued)

(-20°C &lt; Ta &lt; 60°C)

Symbol	Parameter	Conditions	Min.	Typ.	Max.	Unit	Circuit (1)
t <sub>DET4</sub>	Output Delay of Excess Charge-current	V <sub>DD</sub> = 3.1 V, V <sub>RSENS</sub> = 0 V to -0.5 V, V <sub>-</sub> = V <sub>RSENS</sub>	10.7	16	23.6	ms	G
t <sub>REL4</sub>	Output Delay of Release from Excess Charge-current	V <sub>DD</sub> = 3.1 V, V <sub>-</sub> = -0.5 V to 0 V, V <sub>-</sub> = V <sub>RSENS</sub>	0.65	1.2	1.93	ms	G
V <sub>DS</sub>	Delay Time Shortening Mode Voltage	V <sub>DD</sub> = 3.6 V	-2.7	-2.0	-1.2	V	G
V <sub>OL1</sub>	Nch ON-Voltage of C <sub>OUT</sub>	I <sub>ol</sub> = 50 μA, V <sub>DD</sub> = 4.55 V		0.4	0.5	V	H
V <sub>OH1</sub>	Pch ON-Voltage of C <sub>OUT</sub>	I <sub>oh</sub> = -50 μA, V <sub>DD</sub> = 3.9 V	3.4	3.7		V	I
V <sub>OL2</sub>	Nch ON-Voltage of D <sub>OUT</sub>	I <sub>ol</sub> = 50 μA, V <sub>DD</sub> = 1.9 V		0.2	0.5	V	J
V <sub>OH2</sub>	Pch ON-Voltage of D <sub>OUT</sub>	I <sub>oh</sub> = -50 μA, V <sub>DD</sub> = 3.9 V	3.4	3.7		V	K
I <sub>DD</sub>	Supply Current	V <sub>DD</sub> = 3.9 V, V <sub>-</sub> = 0 V		4.0	8.7	μA	L
I <sub>standby</sub>	Standby Current	V <sub>DD</sub> = 2.0 V			0.12	μA	L

All of these specifications are guaranteed by design, not tested in mass production.

(1) Refer to *TEST CIRCUITS* for detail information.

## R5486K Electrical Characteristics

(-40°C &lt; Ta &lt; 85°C)

Symbol	Parameter	Conditions	Min.	Typ.	Max.	Unit	Circuit (1)
V <sub>NOCHG</sub>	Maximum Operating Voltage for Inhibition of Charger	Voltage Defined as V <sub>DD</sub> - V <sub>SS</sub> , V <sub>DD</sub> - V <sub>-</sub> = 4 V	V <sub>NOCHG</sub> -0.423	V <sub>NOCHG</sub>	V <sub>NOCHG</sub> +0.44	V	A
V <sub>DET1</sub>	Over-charge Threshold Voltage	R1 = 330 Ω	V <sub>DET1</sub> ≤ 4.5 V	V <sub>DET1</sub>	V <sub>DET1</sub> -0.033	V	B
			V <sub>DET1</sub> > 4.5 V		V <sub>DET1</sub> -0.038		
t <sub>VDET1</sub>	Output Delay of Over-charge	V <sub>DD</sub> = 3.6V → V <sub>DET1</sub> + 0.05V	0.67	1.0	1.55	s	B
t <sub>VREL1</sub>	Release Delay for VD1	V <sub>DD</sub> = 3.9 V, V <sub>-</sub> = 0 V → 1 V	10.2	16	26.0	ms	C
V <sub>DET2</sub>	Over-discharge Threshold	Detect falling edge of supply voltage	V <sub>DET2</sub> -0.043	V <sub>DET2</sub>	V <sub>DET2</sub> +0.040	V	D
t <sub>VDET2</sub>	Output Delay of Over-discharge	V <sub>DD</sub> = V <sub>DET2</sub> + 0.13 V → V <sub>DET2</sub> - 0.08 V	13.1	20	31.8	ms	D
t <sub>VREL2</sub>	Release Delay for VD2	V <sub>DD</sub> = 1.9 V → V <sub>DET2</sub> + 0.08 V	0.65	1.2	2.04	ms	E
V <sub>DET31</sub>	Excess Discharge-current Threshold	Detect rising edge of RSENS pin voltage	V <sub>DET31</sub> < 0.038V	V <sub>DET31</sub>	V <sub>DET31</sub> -0.0042	V	F
			V <sub>DET31</sub> ≥ 0.038V		V <sub>DET31</sub> x0.89		
t <sub>VDET31</sub>	Output Delay of Excess Discharge-current 1	V <sub>DD</sub> = 3.0 V, V <sub>RSENS</sub> = 0 V to V <sub>DET31</sub> x 1.18 V <sub>-</sub> = V <sub>RSENS</sub>	t <sub>VDET31</sub> x0.66	t <sub>VDET31</sub>	t <sub>VDET31</sub> x1.57	s	F
V <sub>DET32</sub>	Excess Discharge-current Threshold	Detect rising edge of RSENS pin voltage, V <sub>-</sub> = 0 V	V <sub>DET32</sub> < 0.038V	V <sub>DET32</sub>	V <sub>DET32</sub> -0.0042	V	F
			V <sub>DET32</sub> ≥ 0.038V		V <sub>DET32</sub> x0.89		
t <sub>VDET32</sub>	Output Delay of Excess Discharge-current 2	V <sub>DD</sub> = 3.0V, V <sub>RSENS</sub> = 0V to 0.1V, V <sub>-</sub> = V <sub>RSENS</sub>	7.4	12	19.7	ms	F
t <sub>VREL3</sub>	Output Delay of Release from Excess Discharge-current	V <sub>DD</sub> = 3.1 V, V <sub>-</sub> = 3.1 V to 0 V V <sub>-</sub> = V <sub>RSENS</sub>	0.65	1.2	2.0	ms	F
V <sub>SHORT</sub>	Short Protection Voltage	V <sub>DD</sub> = 3.1 V, V <sub>RSENS</sub> = V <sub>-</sub>	V <sub>SHORT</sub> -0.050	V <sub>SHORT</sub>	V <sub>SHORT</sub> +0.050	V	F
t <sub>SHORT</sub>	Delay Time for Short Protection <sup>(2)</sup>	V <sub>DD</sub> = 3.1V, V <sub>RSENS</sub> = 0V to 3.1V, V <sub>-</sub> = V <sub>RSENS</sub>	160	250	495	μs	F
R <sub>SHORT</sub>	Reset Resistance for Excess Current Protection	V <sub>DD</sub> = 3.6 V, V <sub>-</sub> = 1.0 V	14.4	45	71	kΩ	F
V <sub>DET4</sub>	Excess Charge-current Threshold	Detect falling edge of RSENS pin	V <sub>DET4</sub> > -0.02V	V <sub>DET4</sub>	V <sub>DET4</sub> -0.0041	V	G
			V <sub>DET4</sub> ≤ -0.02V		V <sub>DET4</sub> x1.17		

(1) Refer to TEST CIRCUITS for detail information.

(2) Output Delay Time for Release from Short Protection is the same value as t<sub>VREL3</sub>.

## R5486K Electrical Characteristics

(-40°C &lt; Ta &lt; 85°C)

Symbol	Parameter	Conditions	Min.	Typ.	Max.	Unit	Circuit (1)
t <sub>DET4</sub>	Output Delay of Excess Charge-current	V <sub>DD</sub> = 3.1 V, V <sub>RSENS</sub> = 0 V to -0.5 V, V <sub>-</sub> = V <sub>RSENS</sub>	10.7	16	28.3	ms	G
t <sub>REL4</sub>	Output Delay of Release from Excess Charge-current	V <sub>DD</sub> = 3.1 V, V <sub>-</sub> = -0.5 V to 0 V, V <sub>-</sub> = V <sub>RSENS</sub>	0.65	1.2	2.04	ms	G
V <sub>DS</sub>	Delay Time Shortening Mode Voltage	V <sub>DD</sub> = 3.6 V	-2.7	-2.0	-1.2	V	G
V <sub>OL1</sub>	Nch ON-Voltage of C <sub>OUT</sub>	I <sub>ol</sub> = 50 μA, V <sub>DD</sub> = 4.55 V		0.4	0.5	V	H
V <sub>OH1</sub>	Pch ON-Voltage of C <sub>OUT</sub>	I <sub>oh</sub> = -50 μA, V <sub>DD</sub> = 3.9 V	3.4	3.7		V	I
V <sub>OL2</sub>	Nch ON-Voltage of D <sub>OUT</sub>	I <sub>ol</sub> = 50 μA, V <sub>DD</sub> = 1.9 V		0.2	0.5	V	J
V <sub>OH2</sub>	Pch ON-Voltage of D <sub>OUT</sub>	I <sub>oh</sub> = -50 μA, V <sub>DD</sub> = 3.9 V	3.4	3.7		V	K
I <sub>DD</sub>	Supply Current	V <sub>DD</sub> = 3.9 V, V <sub>-</sub> = 0 V		4.0	9.08	μA	L
I <sub>standby</sub>	Standby Current	V <sub>DD</sub> = 2.0 V			0.12	μA	L

All of these specifications are guaranteed by design, not tested in mass production.

(1) Refer to *TEST CIRCUITS* for detail information.

Test Circuits

A

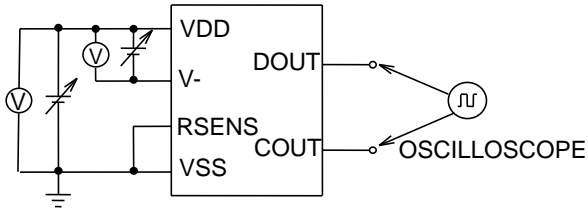

B

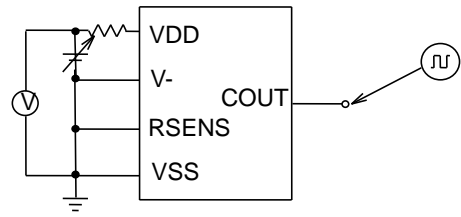

C

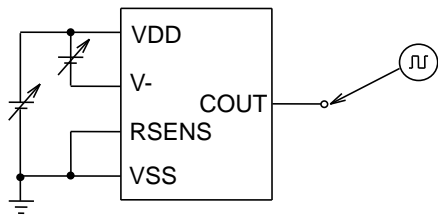

D

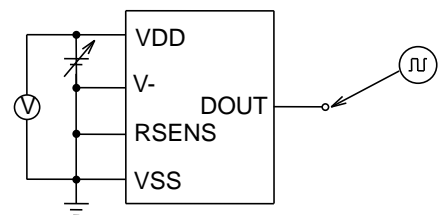

E

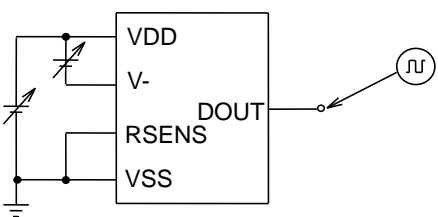

F

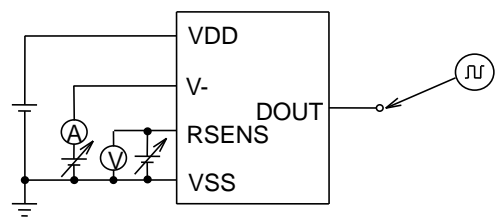

G

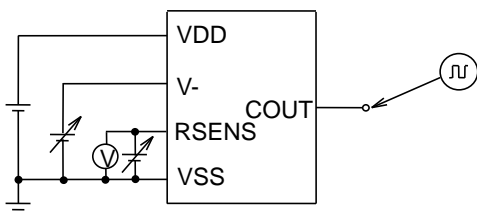

H

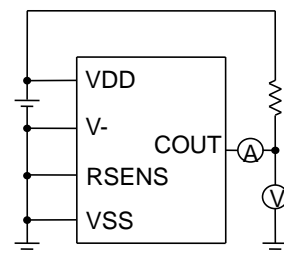

I

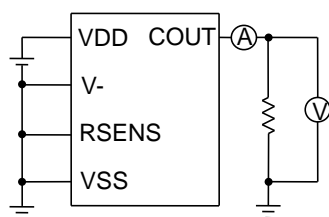

J

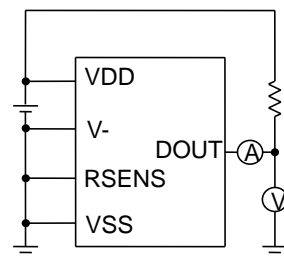

K

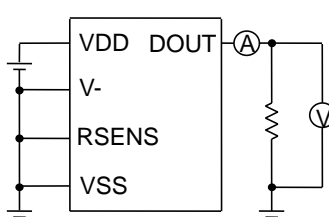

L

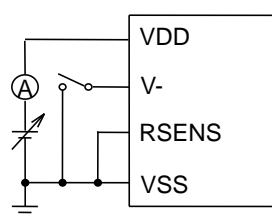

## ■ APPLICATION INFORMATION

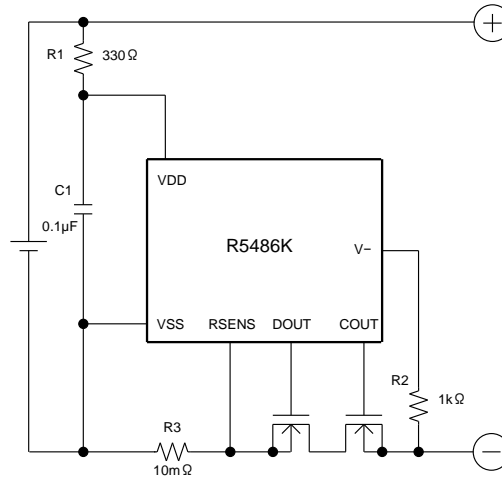

**R5486K Typical Application Circuit**

- R1 and C1 stabilize a supply voltage to the R5486K. A recommended R1 value is equal or less than 1 kΩ. A large value of R1 makes detection voltage shift higher because of the conduction current flowed in the R5486K. Further, to stabilize the operation of R5486K, use the C1 with the value of 0.01 μF or more.
- R1 and R2 can operate also as parts for current limit circuit against reverse charge or applying a charger with excess charging voltage to the R5486K, battery pack. While small value of R1 and R2 may cause over power dissipation rating of the R5486K, therefore a total of “R1+R2” should be 1 kΩ or more. Besides, if a large value of R2 is set, release from over-discharge by connecting a charger might not be possible. Recommended R2 value is equal or less than 10 kΩ.
- R3 is a resistor for sensing an excess current. If the resistance value is too large, power loss becomes also large. By the excess current, if the R3 is not appropriate, the power loss may be beyond the power dissipation of R3. Choose an appropriate R3 according to the cell specification.
- The typical application circuit diagram is just an example. This circuit performance largely depends on the PCB layout and external components. In the actual application, fully evaluation is necessary.
- Over-voltage and the over current beyond the absolute maximum rating should not be forced to the protection IC and external components. Although the short protection circuit is built in the IC, if the positive terminal and the negative terminal of the battery pack are short, during the delay time of short limit detector, large current flows through the FET. Select an appropriate FET with large enough current capacity to prevent the IC from burning damage.



## Sense resistance and on-resistance of the MOSFET selection guideline

Short mode is detected by the current base or the relation between  $V_{DD}$  at short and total on-resistance of external MOSFETs for COUT and DOUT.

If short must be detected by the current base determined by  $V_{SHORT}$  and  $R3$ , the next formula must be true, otherwise, the short current limit becomes  $(V_{DD} - 0.9) / (R3 + R_{SS} (on))$

$$\frac{V_{DD} - 0.9}{R3 + R_{SS} (on)} \geq \frac{V_{SHORT}}{R3}$$

$V_{SHORT}$  = Short Protection Voltage (V)

$R3$  = External Current Sense Resistance ( $\Omega$ )

$R_{SS} (on)$  = External MOSFETs' Total On-Resistance ( $\Omega$ )

$V_{DD}$  =  $V_{DD}$  level at short mode. If  $V_{DD}$  goes down by the short current, the lowest level is  $V_{DD}$ .

Ex. 1

As the  $R_{SENSE}$ , in case that the 5 m $\Omega$  is selected as  $R3$  and if the  $V_{DD}$  becomes 3.0 V, to detect short at 36 A with  $V_{SHORT} = 0.18$  V, the  $R_{SS} (on)$  must be 53 m $\Omega$  or lower.

Ex. 2

As the  $R_{SENSE}$ , in case the 10 m $\Omega$  is selected as  $R3$  and if the  $V_{DD}$  becomes 3.0 V, to detect short at 18 A with  $V_{SHORT} = 0.18$  V, the  $R_{SS} (on)$  must be 106 m $\Omega$  or lower.

If the  $R_{SS} (on)$  value is higher than the value calculated by this formula, the short current limit will be less than the desired value.





1. The products and the product specifications described in this document are subject to change or discontinuation of production without notice for reasons such as improvement. Therefore, before deciding to use the products, please refer to Ricoh sales representatives for the latest information thereon.
2. The materials in this document may not be copied or otherwise reproduced in whole or in part without prior written consent of Ricoh.
3. Please be sure to take any necessary formalities under relevant laws or regulations before exporting or otherwise taking out of your country the products or the technical information described herein.
4. The technical information described in this document shows typical characteristics of and example application circuits for the products. The release of such information is not to be construed as a warranty of or a grant of license under Ricoh's or any third party's intellectual property rights or any other rights.
5. The products listed in this document are intended and designed for use as general electronic components in standard applications (office equipment, telecommunication equipment, measuring instruments, consumer electronic products, amusement equipment etc.). Those customers intending to use a product in an application requiring extreme quality and reliability, for example, in a highly specific application where the failure or misoperation of the product could result in human injury or death (aircraft, spacevehicle, nuclear reactor control system, traffic control system, automotive and transportation equipment, combustion equipment, safety devices, life support system etc.) should first contact us.
6. We are making our continuous effort to improve the quality and reliability of our products, but semiconductor products are likely to fail with certain probability. In order to prevent any injury to persons or damages to property resulting from such failure, customers should be careful enough to incorporate safety measures in their design, such as redundancy feature, fire containment feature and fail-safe feature. We do not assume any liability or responsibility for any loss or damage arising from misuse or inappropriate use of the products.
7. Anti-radiation design is not implemented in the products described in this document.
8. The X-ray exposure can influence functions and characteristics of the products. Confirm the product functions and characteristics in the evaluation stage.
9. WLCSP products should be used in light shielded environments. The light exposure can influence functions and characteristics of the products under operation or storage.
10. There can be variation in the marking when different AOI (Automated Optical Inspection) equipment is used. In the case of recognizing the marking characteristic with AOI, please contact Ricoh sales or our distributor before attempting to use AOI.
11. Please contact Ricoh sales representatives should you have any questions or comments concerning the products or the technical information.



**Ricoh is committed to reducing the environmental loading materials in electrical devices with a view to contributing to the protection of human health and the environment.**

Ricoh has been providing RoHS compliant products since April 1, 2006 and Halogen-free products since April 1, 2012.

**RICOH** RICOH ELECTRONIC DEVICES CO., LTD.

**Official website**

<https://www.n-redc.co.jp/en/>

**Contact us**

<https://www.n-redc.co.jp/en/buy/>

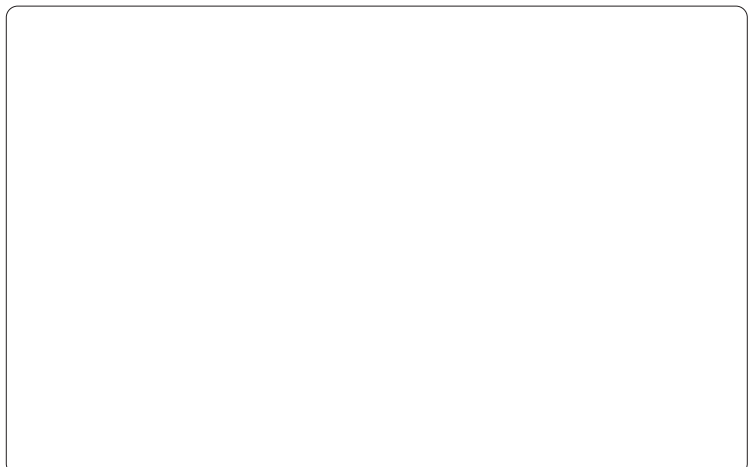

## X-ON Electronics

Largest Supplier of Electrical and Electronic Components

*Click to view similar products for [Battery Management](#) category:*

*Click to view products by [Nisshinbo](#) manufacturer:*

Other Similar products are found below :

[MP26121DQ-LF-P](#) [NCP1855FCCT1G](#) [FAN54063UCX](#) [LC05132C01NMTTTG](#) [SN2040DSQR](#) [ME4075AM5G](#) [AP5054HTCER](#) [TC2120-NB](#) [XPD977B](#) [XPD977B18](#) [4056H](#) [DW01](#) [DW06](#) [CM1002-UD](#) [CM1002-W](#) [CM1002-X](#) [CM1002-Y](#) [CM1006-B](#) [CM1006-Q](#) [CM1006-WB](#) [CM1006-LCD](#) [CM1006-LBD](#) [CM1006-WF](#) [CM1006-LF](#) [CM1006-WG](#) [CM1006-WH](#) [CM1006-LG](#) [CM1003-S02BD](#) [CM1003-S09EA](#) [CM1003-S10ED](#) [CM1003-S11ED](#) [CM1003-S12BC](#) [CM1003-S13CC](#) [CM1003-S24BC](#) [CM1003-S26BC](#) [CM1003-WAD](#) [CM1003-BBD](#) [CM1003-BFD](#) [CM1003-BND](#) [CM1003-BLD](#) [CM1003-DAD](#) [CM1003-BMD](#) [CM1003-BPD](#) [CM1003-BKD](#) [CM1003-BAE](#) [CM1003-BHE](#) [CM1102B-FF](#) [CM1102B-FD](#) [CM1102B-GD](#) [CM1112-DAE](#)