

## 2 to 5 Serial Cell Li-ion Battery Protection IC for Secondary Protection

NO.EA-425-191227

### OVERVIEW

The R5640G is an overcharge protection IC for 2- to 5- series cell Li-ion / Li-polymer rechargeable battery pack, with built-in high-accuracy voltage detection circuits and delay circuits. Controlling the supply voltage to the CTLC pin can control the COUT pin output. The shutdown detection can reduce the supply current to the minimum.

### KEY BENEFITS

- Reducing the supply current to 0.2  $\mu$ A or less after shutdown detection can achieve the longer battery life.
- Cascading the R5640G of 2 or more is adaptable to the battery pack of 6 or more cells and results in a reduction of external parts.
- Be adaptable to 30 V input voltage by using high-voltage process.

### KEY SPECIFICATIONS

- Overcharge Detection Voltage( $V_{DET1n}^{(1)}$ ): 2.90 V to 4.60 V (5 mV step)
- Overcharge Detection Voltage Accuracy:  $\pm 0.016$  V ( $T_a = 25^\circ\text{C}$ )  
 $\pm 0.025$  V ( $0^\circ\text{C} < T_a < 60^\circ\text{C}$ )
- Overcharge Release Voltage( $V_{REL1n}^{(1)}$ ):  
 $V_{DET1n} - 0V^{(2)}$  to  $V_{DET1n} - 0.4V$  ( $V_{DET1} \geq 3.0V$ , 50 mV step) /  
 $V_{DET1n} - 0V^{(2)}$  to  $V_{DET1n} - 0.35V$  ( $V_{DET1} < 3.0V$ , 50 mV step)
- Overcharge Detection Delay Time: 2 / 4 / 6 / 10 / 16 sec
- Release Condition: Voltage Release Type
- Low Supply Current: Typ. 2.5  $\mu$ A
- Shutdown Current: Max. 0.2  $\mu$ A
- Shutdown Detection Voltage: Typ. 2.1V $\pm$ 0.3V / 2.5V $\pm$ 0.3V / 3.7V $\pm$ 0.3V
- 2 to 5 Cells Selectable Battery Protection by External Wirings
- Selectable Timer Reset Delay Function
- Available Cascade Connection
- CTLC Pin Detection Delay Time: 2 msec
- Output Type: Pch. Open-drain of Internal Regulator

### OPTIONAL FUNCTIONS

User-selectable Delay Time and Timer Reset Delay Function:

Code (\$)	Overcharge Detection Delay Time
A	2 sec
B	4 sec
C	6 sec
D	10 sec
E	16 sec

Code (*)	Timer Reset Delay Function
A	Disable
B	Enable

### TYPICAL APPLICATION CIRCUIT

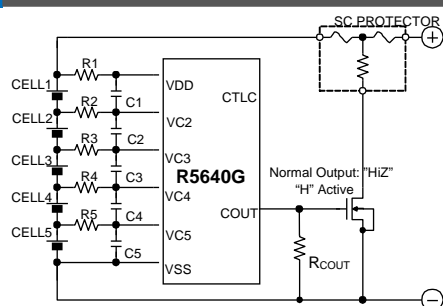

Typical Application Circuits for 5 Cells Protection

### PACKAGE

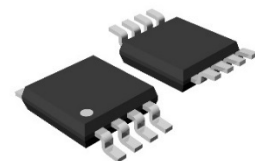

MSOP-8

3.0 mm x 4.9 mm x 0.85 mm

### APPLICATIONS

- Li-Ion or Li-Polymer Battery Protection

(1)  $V_{DET1n}, V_{REL1n}$ :  $n = 1, 2, 3, 4, 5$

(2) Min. 4.05 V when shutdown detection voltage ( $V_{SHTh}$ ) is 3.7 V.

## SELECTION GUIDE

Overcharge detection / release voltages and delay time are user-selectable options.

### Selection Guide

Product Name	Package	Quantity per Reel	Pb Free	Halogen Free
R5640Gxxx\$*-E2-FE	MSOP-8	3,000	Yes	Yes

xxx: Specify the combination of the overcharge detection voltage ( $V_{DET1n}$ ), the overcharge release voltage ( $V_{REL1n}$ ), and the shutdown detection voltage ( $V_{SHTn}$ ).

$V_{DET1n}^{(1)}$ : 2.9 V to 4.6 V in 5 mV step

$V_{REL1n}^{(1)}$ :  $V_{DET1n}-0V^{(2)}$  to  $V_{DET1n}-0.4V$  ( $V_{DET1} \geq 3.0V$ ) /  $V_{DET1n}-0V^{(2)}$  to  $V_{DET1n}-0.35V$  ( $V_{DET1} < 3.0V$ )  
in 50 mV step

$V_{SHTn}^{(1)}$ : 2.1V / 2.5V / 3.7 V

\$: Specify the delay time code defined a combination of the overcharge detection delay time ( $t_{VDET1}$ ), the overcharge release delay time ( $t_{VREL1}$ ), and the CTLC detection delay time ( $t_{CDET}$ ).

Code	$t_{VDET1}$ (s)	$t_{VREL1}$ (ms)	$t_{CDET}$ (ms)
A	2	16.5	2
B	4	16.5	2
C	6	16.5	2
D	10	16.5	2
E	16	16.5	2

\*: Specify the timer reset delay function.

Code	Timer Reset Delay Function
A	Disable
B	Enable

<sup>(1)</sup>  $V_{DET1n}$ ,  $V_{REL1n}$ ,  $V_{SHTn}$ : n = 1, 2, 3, 4, 5

<sup>(2)</sup> Min. 4.05 V when shutdown detection voltage ( $V_{SHTn}$ ) is 3.7 V.

**Product Code List**

The product code is determined by the combination of the set output voltage (overcharge detector threshold:  $V_{DET1n}$ , overcharge release voltage:  $V_{REL1n}$ , shutdown detector threshold:  $V_{SHTn}$ ) and the delay time (overcharge detection delay time:  $t_{VDET1}$ , overcharge release delay time:  $t_{VREL1}$ , CTLC detection delay time:  $t_{CDET}$ ) and the timer reset delay time option ( $t_{VTR}$ ).

**Product Code Table**

Product Name	Set Output Voltage (V)			Delay Time			Timer Reset Delay Time (Yes/No <sup>(1)</sup> )
	$V_{DET1n}$	$V_{REL1n}$	$V_{SHTn}$	$t_{VDET1}(s)$	$t_{VREL1}(ms)$	$t_{CDET}(ms)$	
R5640G101BB	3.750	3.450	2.500	4	16.5	2	Yes
R5640G251DA	4.220	4.050	3.700	10	16.5	2	No
R5640G252AB	4.220	4.120	3.700	2	16.5	2	Yes
R5640G254AB	4.200	4.100	3.700	2	16.5	2	Yes
R5640G256AB	4.275	4.100	3.700	2	16.5	2	Yes
R5640G301BA	4.300	4.000	2.500	4	16.5	2	No
R5640G302BA	4.350	4.050	2.500	4	16.5	2	No
R5640G305BB	4.300	3.900	2.500	4	16.5	2	Yes
R5640G471AA	2.900	2.700	2.100	2	16.5	2	No
R5640G472AA	3.000	2.800	2.100	2	16.5	2	No

---

<sup>(1)</sup> "No" means the timer reset delay time option is absence.

---

**BLOCK DIAGRAM**

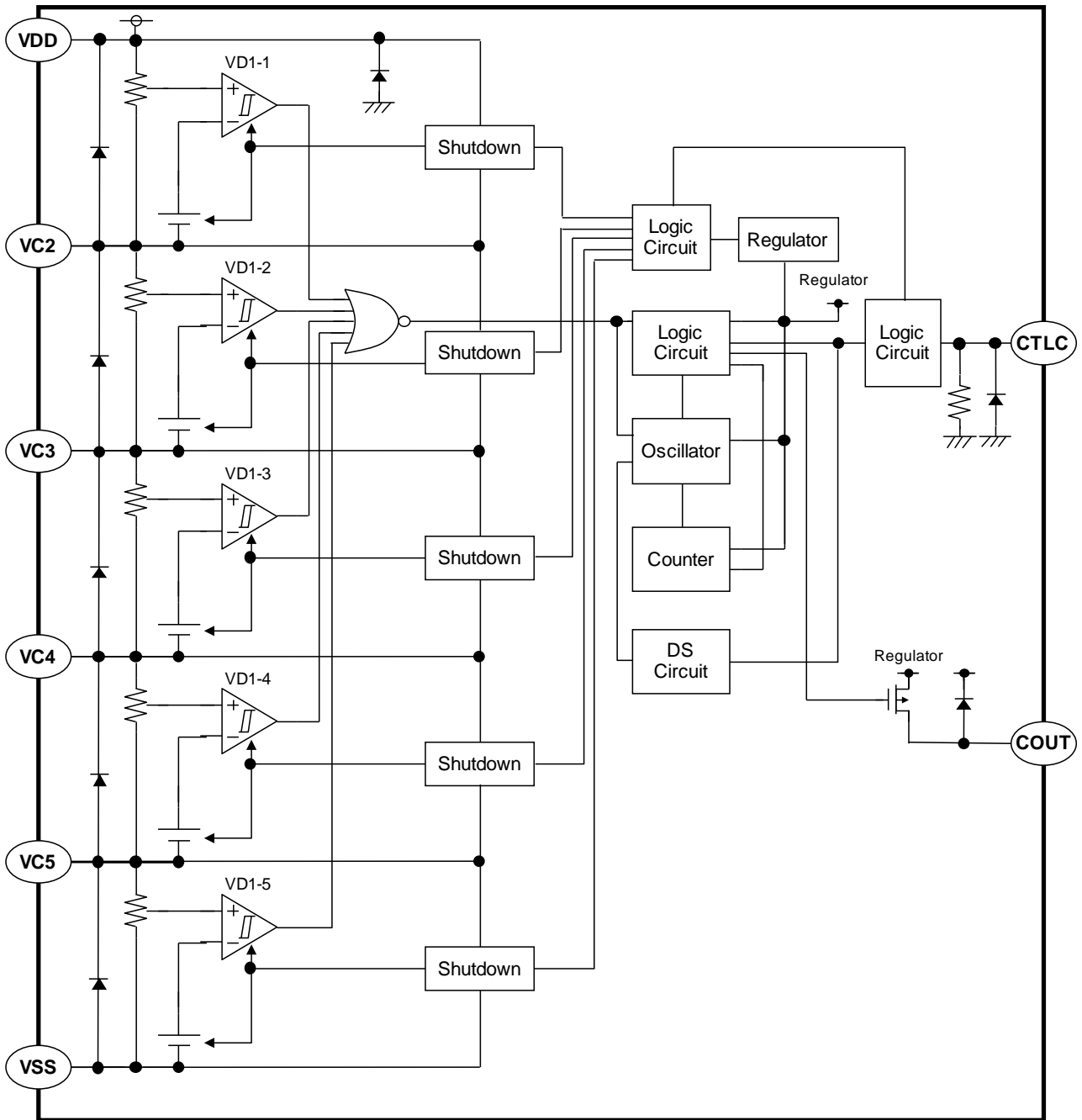

R5640G Block Diagram

## PIN DESCRIPTION

Top View

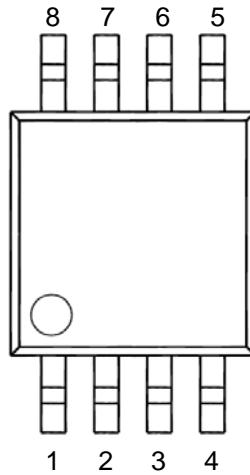

MSOP-8 Pin Configuration

### R5640G Pin Description

Pin No.	Symbol	Description
1	VDD	Power Supply Pin, Positive Terminal for CELL1
2	VC2	Positive Terminal for CELL2
3	VC3	Positive Terminal for CELL3
4	VC4	Positive Terminal for CELL4
5	VC5	Positive Terminal for CELL5
6	VSS	Ground Pin
7	CTLC	COUT Control Pin / Output Delay Time Shortening Pin
8	COUT	Overcharge Detection Output Pin, Pch. Open-drain Output

**ABSOLUTE MAXIMUM RATINGS**(Ta = 25°C, V<sub>SS</sub> = 0V)

Symbol	Item	Ratings	Unit
V <sub>DD</sub>	Supply Voltage	-0.3 to 30	V
	(Positive Terminal Voltage for CELL1)	V <sub>C2</sub> -0.3 to V <sub>C2</sub> +6.5	V
V <sub>C2</sub>	Positive Terminal Voltage for CELL2	V <sub>C3</sub> -0.3 to V <sub>C3</sub> +6.5	V
V <sub>C3</sub>	Positive Terminal Voltage for CELL3	V <sub>C4</sub> -0.3 to V <sub>C4</sub> +6.5	V
V <sub>C4</sub>	Positive Terminal Voltage for CELL4	V <sub>C5</sub> -0.3 to V <sub>C5</sub> +6.5	V
V <sub>C5</sub>	Positive Terminal Voltage for CELL5	-0.3 to 6.5	V
V <sub>CTL</sub>	CTL Pin Voltage	-0.3 to 30	V
V <sub>CO</sub>	CO Pin Output Voltage	V <sub>OH1</sub> -30 to V <sub>OH1</sub> +0.3	V
P <sub>D</sub>	Power Dissipation (MSOP-8, JEDEC STD.51-7)	960	mW
T <sub>j</sub>	Junction Temperature Range	-40 to 125	°C
T <sub>stg</sub>	Storage Temperature Range	-55 to 125	°C

**ABSOLUTE MAXIMUM RATINGS**

Electronic and mechanical stress momentarily exceeded absolute maximum ratings may cause the permanent damages and may degrade the life time and safety for both device and system using the device in the field. The functional operation at or over these absolute maximum ratings is not assured.

**RECOMMENDED OPERATING CONDITION**

Symbol	Item	Rating	Unit
V <sub>DD</sub>	Operating Input Voltage	4.0 to 25 / V <sub>C2</sub> +5 V	V
T <sub>a</sub>	Operating Temperature Range	-40 to 85	°C

**RECOMMENDED OPERATING CONDITIONS**

All of electronic equipment should be designed that the mounted semiconductor devices operate within the recommended operating conditions. The semiconductor devices cannot operate normally over the recommended operating conditions, even if when they are used over such conditions by momentary electronic noise or surge. And the semiconductor devices may receive serious damage when they continue to operate over the recommended operating conditions.

## ELECTRICAL CHARACTERISTICS

$V_{CELLn} = CELLn$  (Ex.  $V_{CELL1}$  is a voltage difference between VDD and VC2),  $n = 1, 2, 3, 4, 5$ , unless otherwise noted. The specifications surrounded by   are guaranteed by Design Engineering at  $0^{\circ}\text{C} \leq T_a \leq 60^{\circ}\text{C}$ .

( $T_a = 25^{\circ}\text{C}$ )

Symbol	Parameter	Conditions	Ratings			Unit	Circuit (1)
			Min.	Typ.	Max.		
$V_{DET1n}$	CELLn overcharge detection voltage	at rising edge of voltage	$V_{DET1n}$ -0.016V <span style="border: 1px solid black; padding: 2px;"><math>V_{DET1n}</math></span> -0.025V	$V_{DET1n}$	$V_{DET1n}$ +0.016V <span style="border: 1px solid black; padding: 2px;"><math>V_{DET1n}</math></span> +0.025V	V	A
$V_{REL1n}$	CELLn overcharge release voltage	at falling edge of voltage	$V_{REL1n}$ -0.050V	$V_{REL1n}$	$V_{REL1n}$ +0.050V	V	A
$t_{VDET1}$	Overcharge detection delay time	$V_{CELLn} = V_{DET1n} - 0.1\text{V}$ ( $n=2,3,4,5$ ) $V_{CELL1} = V_{DET1n} - 0.1\text{V} \rightarrow 4.7\text{V}$	$t_{VDET1}$ $\times 0.8$	$t_{VDET1}$	$t_{VDET1}$ $\times 1.2$	s	B
$t_{VD1DS}$	Overcharge detection delay time at delay shortening mode	$V_{CELLn} = V_{DET1n} - 0.1\text{V}$ ( $n=2,3,4,5$ ) $V_{CELL1} = V_{DET1n} - 0.1\text{V} \rightarrow 4.7\text{V}$ $V_{CTL C} = 2.0\text{V}$	0.5	4	8	ms	B
$t_{VREL1}$	Overcharge release delay time	$V_{CELLn} = V_{REL1n} - 0.1\text{V}$ ( $n=2,3,4,5$ ) $V_{CELL1} = 4.7\text{V} \rightarrow V_{REL1n} - 0.1\text{V}$	$t_{VREL1}$ $\times 0.8$	$t_{VREL1}$	$t_{VREL1}$ $\times 1.2$	ms	B
$t_{VTR}$	Overcharge detection timer reset delay time (2)	$V_{CELLn} = V_{DET1n} + 0.05\text{V}$ $\rightarrow V_{REL1n} - 0.10\text{V}$ $\rightarrow V_{DET1n} + 0.05\text{V}$ $\rightarrow V_{REL1n} - 0.10\text{V}$	2	6	10	ms	B
$V_{SHTn}$	Shutdown detection voltage	at falling edge of voltage	$V_{SHTn}$ -0.3V	$V_{SHTn}$	$V_{SHTn}$ +0.3V	V	C
$V_{IH}$	CTL C pin input voltage, high		2.8			V	D
$V_{IM}$	CTL C pin input voltage, middle		1.9		2.4	V	D
$t_{CDET}$	CTL C pin detection delay time	$V_{CELLn} = V_{DET1n} - 0.1\text{V}$ $V_{CTL C} = 0.0\text{V} \rightarrow 3.0\text{V}$ $V_{CELLn} = V_{SHTn} - 0.4\text{V}$ $V_{CTL C} = 0.0\text{V} \rightarrow 3.0\text{V}$ (at shutdown)	$t_{CDET}$ $\times 0.8$	$t_{CDET}$ $t_{CDET} + 1$	$t_{CDET}$ $\times 1.2$	ms	D
$I_{CTL C}$	CTL C pin current	$V_{CELLn} = V_{DET1n} - 0.1\text{V}$ , $V_{CTL C} = 3.0\text{V}$	0.13	0.3	0.55	$\mu\text{A}$	D
$I_{LCOUT}$	COU T pin off-leakage current	$V_{CELLn} = V_{DET1n} - 0.1\text{V}$ $V_{COU T} = -10.0\text{V}$	-0.1			$\mu\text{A}$	E
$V_{OH1}$	COU T pin Pch. ON voltage1	$I_{OH} = -1\mu\text{A}$ , $V_{CELLn} = 4.7\text{V}$	4.0	4.7	5.4	V	F
$V_{OH2}$	COU T pin Pch. ON voltage2	$I_{OH} = -50\mu\text{A}$ , $V_{CELLn} = 4.7\text{V}$	$V_{OH1}$ -0.5V	$V_{OH1}$ -0.11V		V	G
$I_{SHT}$	Shutdown current	$V_{CELLn} = V_{SHTn} - 0.4\text{V}$			0.2	$\mu\text{A}$	H
$I_{SS}$	Supply Current	$V_{CELLn} = V_{DET1n} - 0.1\text{V}$		2.5	5.0	$\mu\text{A}$	H
$I_{VC2}$	VC2 pin current	$V_{CELLn} = V_{DET1n} - 0.1\text{V}$	-0.3		0.3	$\mu\text{A}$	H
$I_{VC3}$	VC3 pin current	$V_{CELLn} = V_{DET1n} - 0.1\text{V}$	-0.3		0.3	$\mu\text{A}$	H
$I_{VC4}$	VC4 pin current	$V_{CELLn} = V_{DET1n} - 0.1\text{V}$	-0.3		0.3	$\mu\text{A}$	H
$I_{VC5}$	VC5 pin current	$V_{CELLn} = V_{DET1n} - 0.1\text{V}$	-0.3		0.3	$\mu\text{A}$	H

(1) Refer to TEST CIRCUITS for detail information.

(2) For the timer reset delay function enabled product only

Test Circuits

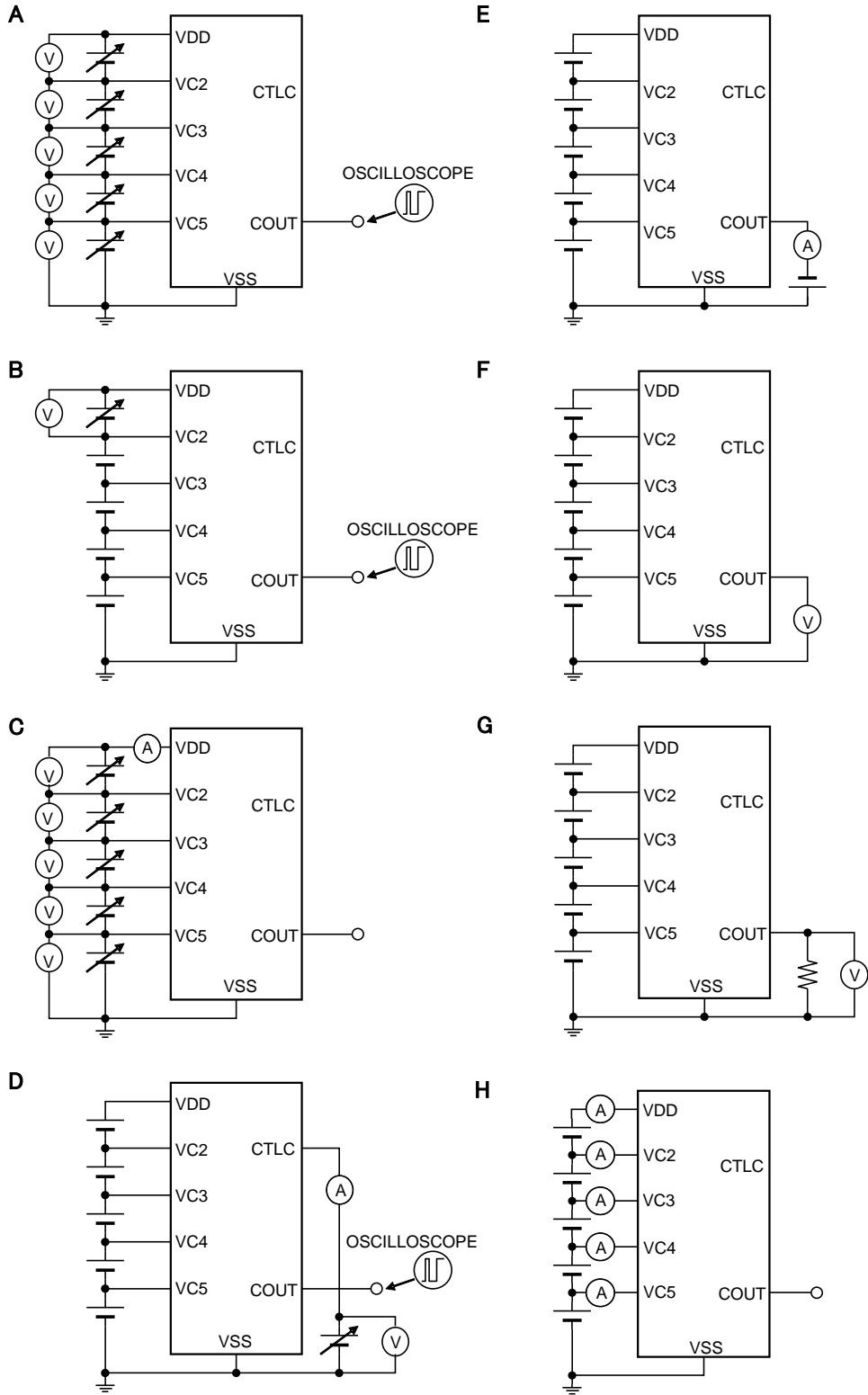



## THEORY OF OPERATION

### Overcharge Detector, $V_{DET1n}$ (n = 1, 2, 3, 4, 5)

During charging, the device supervises the voltage between VDD pin and VC2 pin ( $V_{CELL1}$ ), the voltage between VC2 pin and VC3 pin ( $V_{CELL2}$ ), the voltage between VC3 pin and VC4 pin ( $V_{CELL3}$ ), the voltage between VC4 pin and VC5 pin ( $V_{CELL4}$ ), and the voltage between VC5 pin and VSS pin ( $V_{CELL5}$ ). If at least one of the cell voltages exceeds more than the overcharge detection voltage ( $V_{DET1n}$ ), the overcharge is detected, and an external charge control Nch. MOSFET turns on with COUT pin being at "H" level and by cutting a fuse on the charger path, and charge stops. If all the cell voltages become lower than the overcharge release voltage ( $V_{REL1n}$ ), the overcharge is released and COUT pin outputs "Hiz".

The device has internal fixed output delay times for overcharge detection, overcharge detection timer reset, and overcharge release. If the output delay time passes on when any one of the cell voltages is more than  $V_{DET1n}$ , the overcharge is detected. In the case of Timer Reset Delay available version, if all the cell voltages become lower than  $V_{DET1n}$  within the overcharge detection delay time by noise or other reasons, the time period is less than overcharge detection timer reset delay time, the overcharge delay time is accumulated and maintained, and the accumulated delay time reaches the overcharge detection delay time, the overcharge is detected. After detecting overcharge, even if all the cell voltages reduce less than the release voltage, if at least one of the cell voltages exceeds more than the release voltage within the overcharge release delay time, then overcharge is not released.

The COUT pin, which is a Pch. open-drain output type, outputs the output voltage of the internal regulator when "High".

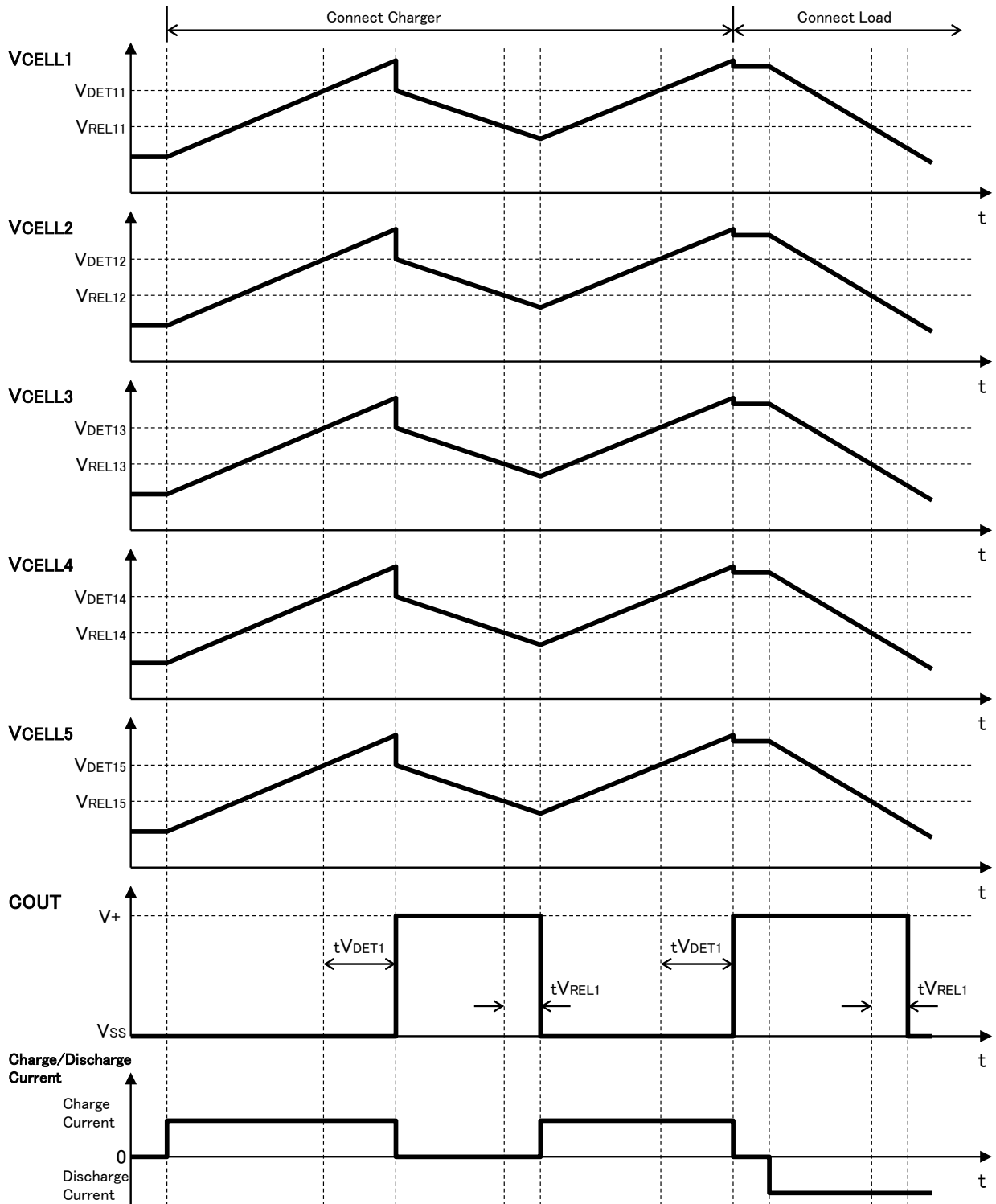

Overcharge Operation Timing Chart

## Shutdown Function

The voltage between VDD pin and VC2 pin ( $V_{CELL1}$ ), the voltage between VC2 pin and VC3 pin ( $V_{CELL2}$ ), the voltage between VC3 pin and VC4 pin ( $V_{CELL3}$ ), the voltage between VC4 pin and VC5 pin ( $V_{CELL4}$ ), and the voltage between VC5 pin and VSS pin ( $V_{CELL5}$ ) are supervised. If all of  $V_{CELLn}$  ( $n=1$  to 5) become less than the shutdown detection voltage, the device halts the operation, and the supply current (shutdown current) of the device can be reduced to the minimum. If one of  $V_{CELLn}$  ( $n=1$  to 5) becomes more than the shutdown detection voltage, the device will release from the shutdown state.

## CTLC Function

When exceeding the CTLC detection delay time or more after supplying the voltage of 2.8 V or more to CTLC pin, the COUT pin outputs “High” level. This function is enabled even in the shutdown state.

By cascading between the COUT pin of the high-voltage side IC and the CTLC pin of the low-voltage side IC, these devices can protect the battery pack for six or more series cell <sup>(1)</sup>. At cascading, the COUT pin output of the high-voltage side is transmitted to the CTLC pin of the low-voltage side and the COUT pin outputs “High”.

## Delay Shortening (DS)

Applying the voltage of 1.9 V to 2.4 V to the CTLC pin can shorten the overcharge detection delay time to a few millisecond (ms).

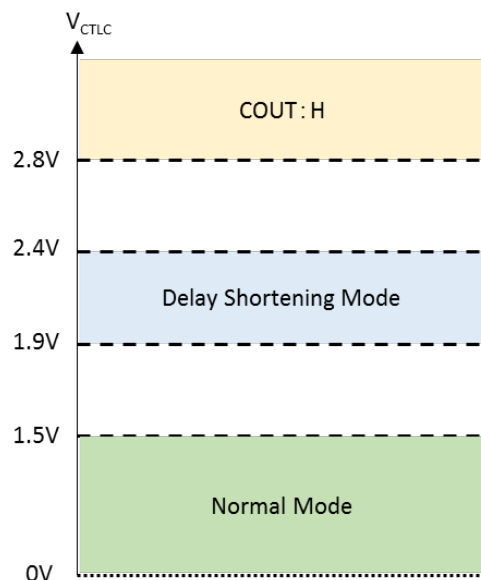

<sup>(1)</sup> Refer to 10-CELL PROTECTION CIRCUIT AT CASCADING in APPLICATION INFORMATION.

**Setting for 2 to 5 Cells Protection**

By short-circuiting between cells, the device can meet as a protection IC for 2 to 5 cells connected in series. The following table indicates pins to short-circuit to VSS depending on protected cells.

<b>Protected Cells</b>	<b>Pins Short-circuiting to VSS</b>
2-cell protection	VC3, VC4, and VC5 pins
3-cell protection	VC4 and VC5 pins
4-cell protection	VC5 pin
5-cell protection	Not short-circuiting

# APPLICATION INFORMATION

## Typical Application Circuits

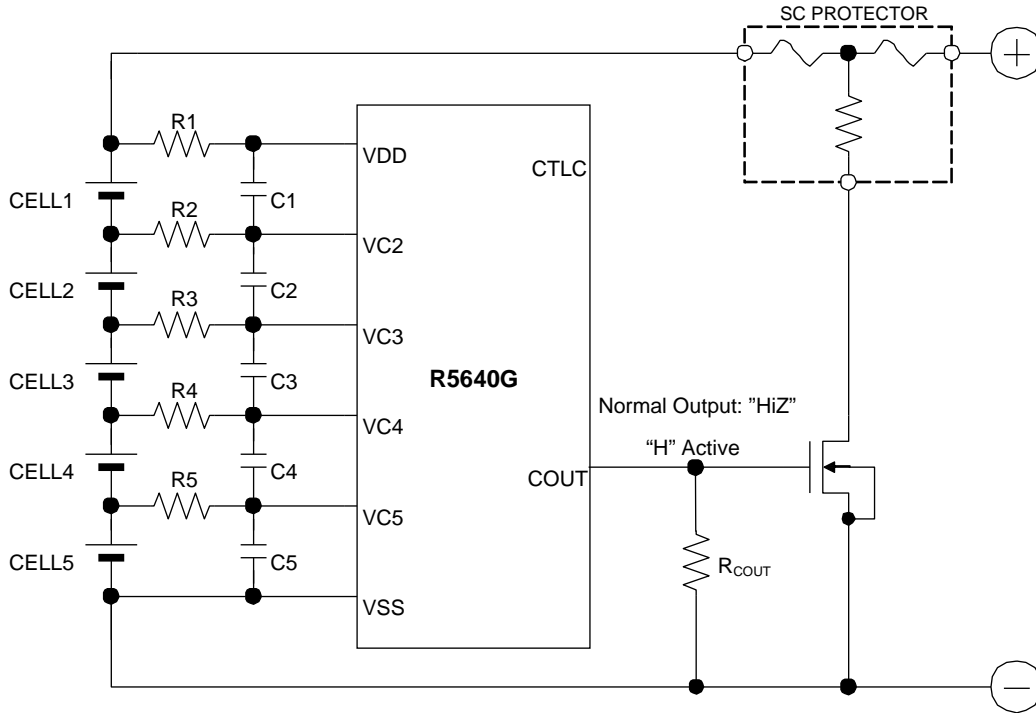

5-cell Protection Circuit

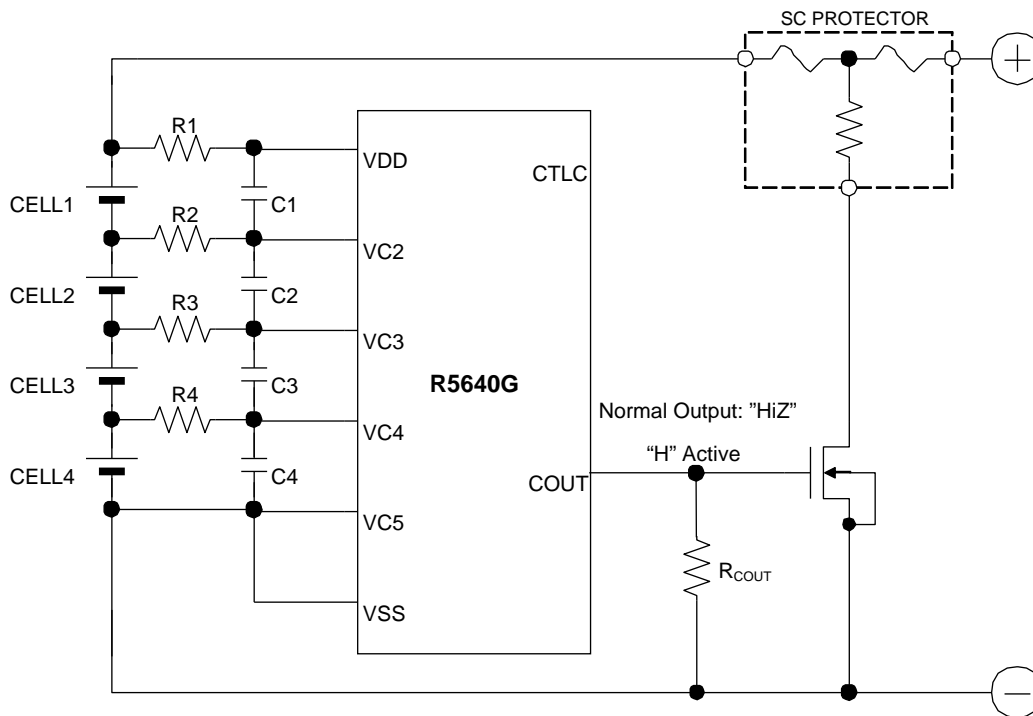

4-cell Protection Circuit

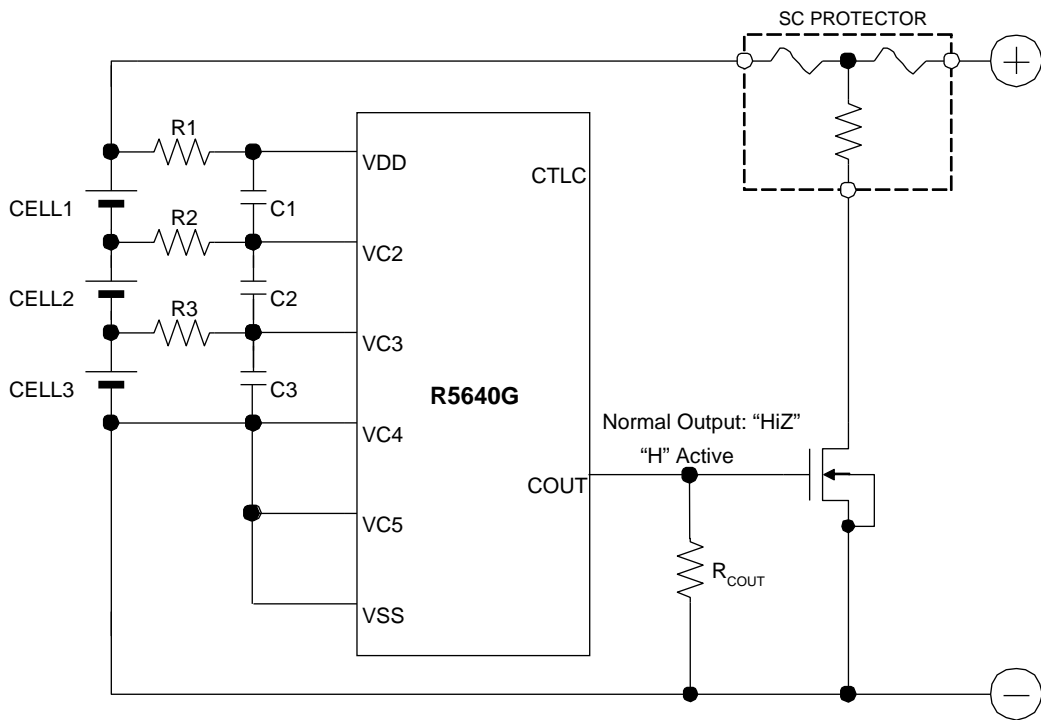

3-cell Protection Circuit

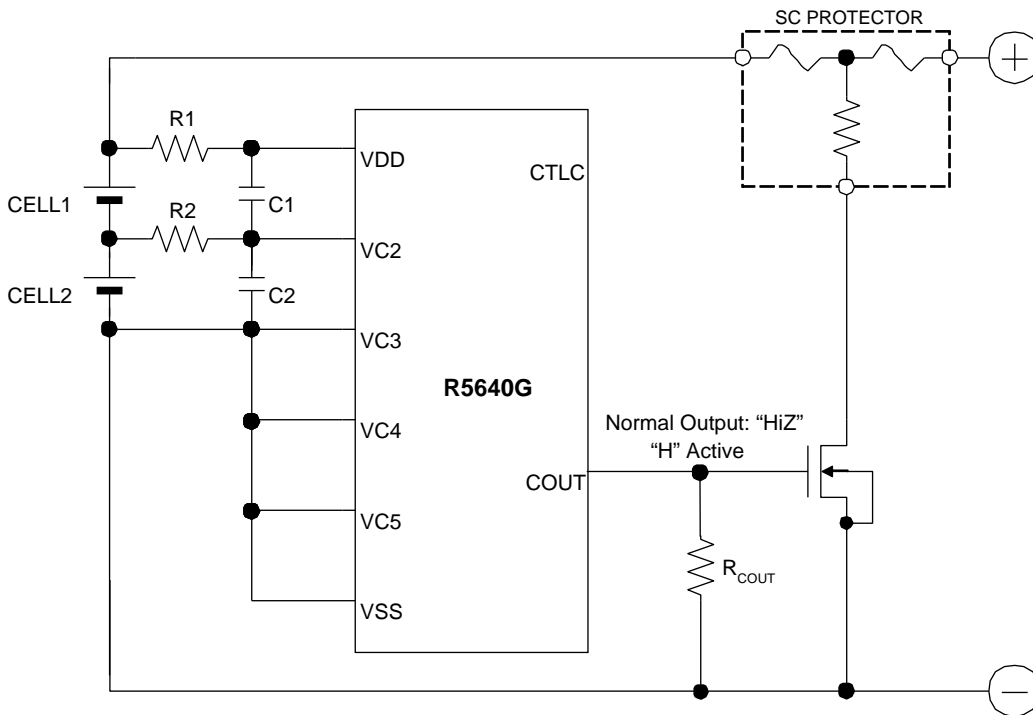

2-cell Protection Circuit

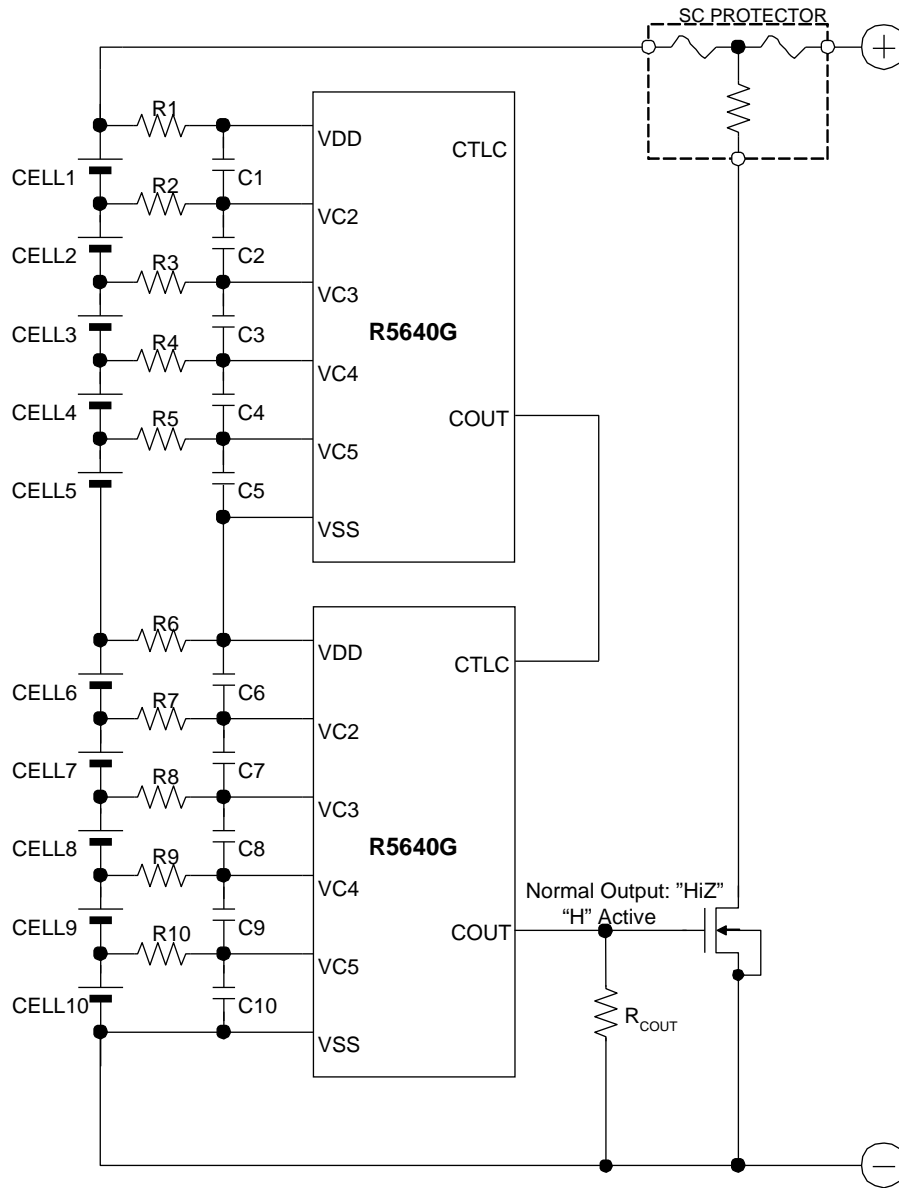

10-cell Protection Circuit at Cascading

**External Components**

Symbol	Typ.	Unit	Permissible Range
R1 / R2 / R3 / R4 / R5	330	$\Omega$	330 to 1000
C1 / C2 / C3 / C4 / C5	0.1	$\mu\text{F}$	0.01 to 1
R <sub>COUT</sub>	1	M $\Omega$	0.5 to 2

**Technical Notes on Component Selection**

- The voltage fluctuation is stabilized with R1 to R5 and C1 to C5. Since increasing resistors of R1 to R5 make the detection voltage be higher by the conduction current at detection, the appropriate value of R1 to R5 must be less than 1k $\Omega$ . And, the appropriate value of C1 to C5 must be 0.01 $\mu\text{F}$  or more in order to make a stable operation of the IC.
- If R<sub>COUT</sub> is small, the supply current of the protect circuit will increase when the COUT pin is "high".
- The typical application circuits are just examples and do not guarantee the operation. Conduct the sufficient evaluation in the actual application circuit in order to select external components.
- The protection IC and external components must not be applied overvoltage and overcurrent beyond the absolute maximum ratings. Especially, after detecting overcharge, a large heater current might flow through the MOSFET during the fuse blowout time. To prevent the MOSFET from being burnt, select a MOSFET with considering a current capacity of it.
- To connect the SC protector, connect the SC protector to the cell must be the last.

**Contact Information for Inquiries regarding SC PROTECTOR**

Dexerials Corporation (Sony Chemical & Information Device Company Ltd.)  
Gate-city Osaki East Tower 8F, 1-11-2 Osaki, Shinagawa, Tokyo, 141-0032  
TEL: 03-5435-3946  
URL: <http://www.dexerials.jp>



The power dissipation of the package is dependent on PCB material, layout, and environmental conditions. The following measurement conditions are based on JEDEC STD. 51-7.

**Measurement Conditions**

Item	Measurement Conditions
Environment	Mounting on Board (Wind Velocity = 0 m/s)
Board Material	Glass Cloth Epoxy Plastic (Four-Layer Board)
Board Dimensions	76.2 mm × 114.3 mm × 0.8 mm
Copper Ratio	Outer Layer (First Layer): Less than 95% of 50 mm Square Inner Layers (Second and Third Layers): Approx. 100% of 50 mm Square Outer Layer (Fourth Layer): Approx. 100% of 50 mm Square
Through-holes	φ 0.3 mm × 32 pcs

**Measurement Result**

(Ta = 25°C, Tjmax = 125°C)

Item	Measurement Result
Power Dissipation	960 mW
Thermal Resistance (θja)	θja = 104°C/W
Thermal Characterization Parameter (ψjt)	ψjt = 31°C/W

θja: Junction-to-Ambient Thermal Resistance

ψjt: Junction-to-Top Thermal Characterization Parameter

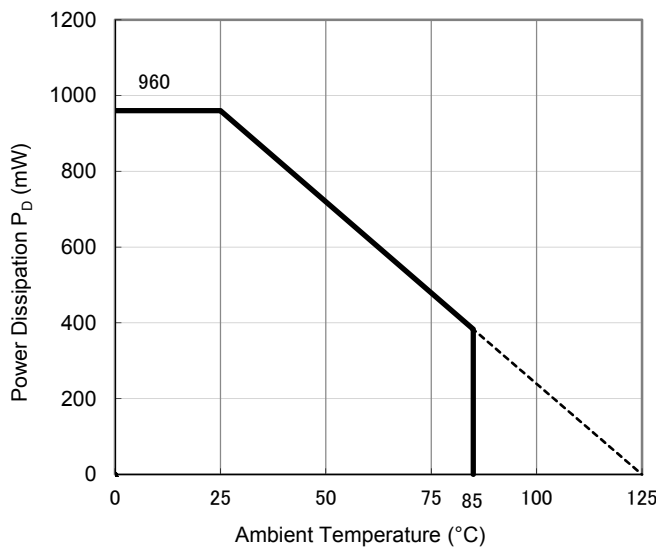

**Power Dissipation vs. Ambient Temperature**

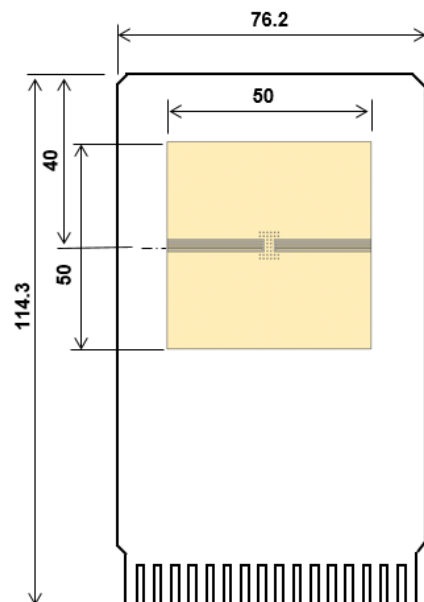

**Measurement Board Pattern**

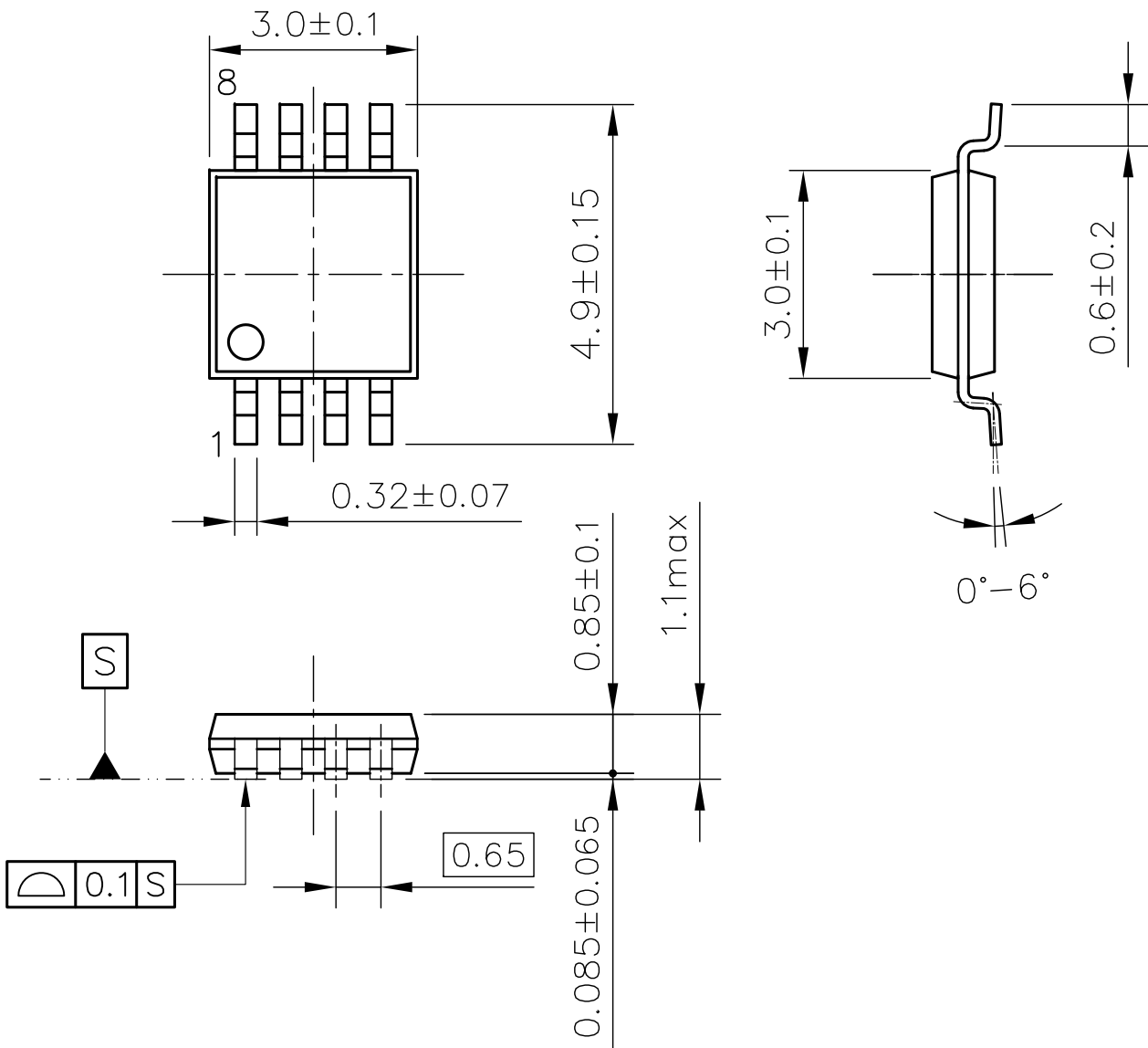

MSOP-8 Package Dimensions (Unit: mm)



1. The products and the product specifications described in this document are subject to change or discontinuation of production without notice for reasons such as improvement. Therefore, before deciding to use the products, please refer to Ricoh sales representatives for the latest information thereon.
2. The materials in this document may not be copied or otherwise reproduced in whole or in part without prior written consent of Ricoh.
3. Please be sure to take any necessary formalities under relevant laws or regulations before exporting or otherwise taking out of your country the products or the technical information described herein.
4. The technical information described in this document shows typical characteristics of and example application circuits for the products. The release of such information is not to be construed as a warranty of or a grant of license under Ricoh's or any third party's intellectual property rights or any other rights.
5. The products listed in this document are intended and designed for use as general electronic components in standard applications (office equipment, telecommunication equipment, measuring instruments, consumer electronic products, amusement equipment etc.). Those customers intending to use a product in an application requiring extreme quality and reliability, for example, in a highly specific application where the failure or misoperation of the product could result in human injury or death (aircraft, spacevehicle, nuclear reactor control system, traffic control system, automotive and transportation equipment, combustion equipment, safety devices, life support system etc.) should first contact us.
6. We are making our continuous effort to improve the quality and reliability of our products, but semiconductor products are likely to fail with certain probability. In order to prevent any injury to persons or damages to property resulting from such failure, customers should be careful enough to incorporate safety measures in their design, such as redundancy feature, fire containment feature and fail-safe feature. We do not assume any liability or responsibility for any loss or damage arising from misuse or inappropriate use of the products.
7. Anti-radiation design is not implemented in the products described in this document.
8. The X-ray exposure can influence functions and characteristics of the products. Confirm the product functions and characteristics in the evaluation stage.
9. WLCSP products should be used in light shielded environments. The light exposure can influence functions and characteristics of the products under operation or storage.
10. There can be variation in the marking when different AOI (Automated Optical Inspection) equipment is used. In the case of recognizing the marking characteristic with AOI, please contact Ricoh sales or our distributor before attempting to use AOI.
11. Please contact Ricoh sales representatives should you have any questions or comments concerning the products or the technical information.



**Ricoh is committed to reducing the environmental loading materials in electrical devices with a view to contributing to the protection of human health and the environment.**

Ricoh has been providing RoHS compliant products since April 1, 2006 and Halogen-free products since April 1, 2012.

**RICOH** RICOH ELECTRONIC DEVICES CO., LTD.

**Official website**

<https://www.e-devices.ricoh.co.jp/en/>

**Contact us**

<https://www.e-devices.ricoh.co.jp/en/support/>

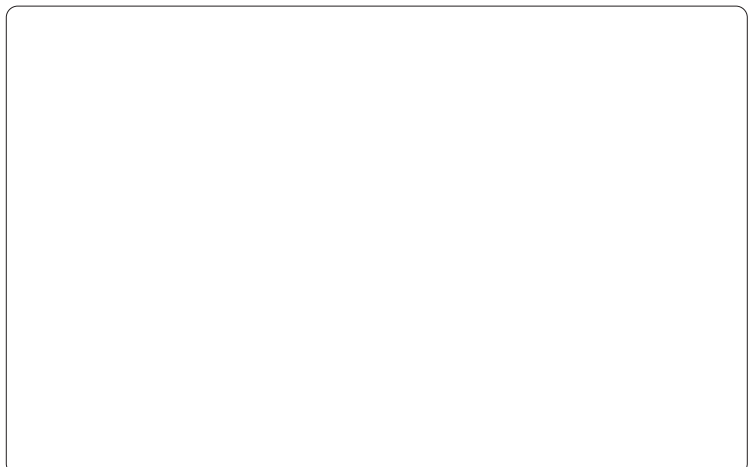

## X-ON Electronics

Largest Supplier of Electrical and Electronic Components

*Click to view similar products for [Battery Management](#) category:*

*Click to view products by [Nisshinbo](#) manufacturer:*

Other Similar products are found below :

[MP26121DQ-LF-P](#) [NCP1855FCCT1G](#) [FAN54063UCX](#) [LC05132C01NMTTTG](#) [SN2040DSQR](#) [ME4075AM5G](#) [AP5054HTCER](#) [TC2120-NB](#) [XPD977B](#) [XPD977B18](#) [4056H](#) [DW01](#) [DW06](#) [CM1002-UD](#) [CM1002-W](#) [CM1002-X](#) [CM1002-Y](#) [CM1006-B](#) [CM1006-Q](#) [CM1006-WB](#) [CM1006-LCD](#) [CM1006-LBD](#) [CM1006-WF](#) [CM1006-LF](#) [CM1006-WG](#) [CM1006-WH](#) [CM1006-LG](#) [CM1003-S02BD](#) [CM1003-S09EA](#) [CM1003-S10ED](#) [CM1003-S11ED](#) [CM1003-S12BC](#) [CM1003-S13CC](#) [CM1003-S24BC](#) [CM1003-S26BC](#) [CM1003-WAD](#) [CM1003-BBD](#) [CM1003-BFD](#) [CM1003-BND](#) [CM1003-BLD](#) [CM1003-DAD](#) [CM1003-BMD](#) [CM1003-BPD](#) [CM1003-BKD](#) [CM1003-BAE](#) [CM1003-BHE](#) [CM1102B-FF](#) [CM1102B-FD](#) [CM1102B-GD](#) [CM1112-DAE](#)