

---

### 300 mA Ultra-small Dual LDO Regulator

---

No. EA-202-210715

## OUTLINE

The RP154x is a CMOS-based voltage regulator that provides high ripple rejection, low dropout voltage, high output voltage accuracy, and low supply current. Internally, the RP154x consists of a voltage reference unit, an error amplifier, resistors for setting output voltage, a short current limit circuit and a chip enable circuit.

The RP154x is available in fixed output voltage options. Besides the low supply current by CMOS, the RP154x offers a low dropout voltage by built-in low ON resistance  $r_{ON}$  as well as an extended battery life by a chip enable function. Compared with the existing CMOS-based regulators, the RP154x is further improved in ripple rejection, line transient response, and load transient response. All these features allow the RP154x to become ideal power sources for hand-held communication equipment.

The RP154x is offered in a 6-pin SOT-23-6 package for a single input type and an 8-pin DFN1216-8 package for a dual input type. Both packages are equipped with two LDOs which can achieve high-density mounting.

## FEATURES

- Supply Current ..... Typ. 50  $\mu$ A x 2 (VR1 & VR2)
- Standby Current ..... Typ. 0.1  $\mu$ A x 2 (VR1 & VR2)
- Input Voltage Range ..... 1.4 V to 5.25 V
- Output Voltage Range ..... 0.8 V to 3.7 V (0.1 V steps)
- Output Voltage Accuracy .....  $\pm 1.0\%$  ( $V_{SET} > 2.0$  V,  $T_a = 25^\circ$ C)
- Temperature-Drift Coefficient of Output Voltage ..... Typ.  $\pm 80$  ppm/ $^\circ$ C
- Dropout Voltage ..... Typ. 0.25 V ( $I_{OUT} = 300$  mA,  $V_{SET} = 2.5$  V)
- Ripple Rejection ..... Typ. 75 dB ( $f = 1$  kHz)
- Line Regulation ..... Typ. 0.02%/V
- Packages ..... DFN1216-8, SOT-23-6
- Short-current Limit Circuit ..... Typ. 60 mA
- Overcurrent Protection Circuit
- Ceramic Capacitor Compatible ..... 1.0  $\mu$ A or more

## APPLICATIONS

- Power source for portable communication equipment.
- Power source for electrical appliances such as cameras, VCRs and camcorders.
- Power source for battery-powered equipment.

# RP154x

No. EA-202-210715

## SELECTION GUIDE

The set output voltage, the package type and the auto discharge function<sup>(1)</sup> are user-selectable options.

### Selection Guide

Product Name	Package	Quantity per Reel	Pb Free	Halogen Free
RP154L0xx*-E2	DFN1216-8	5,000 pcs	Yes	Yes
RP154N0xx*-TR-FE	SOT-23-6	3,000 pcs	Yes	Yes

xx: Specify the combination of set output voltage ( $V_{SET}$ ) within the range of 0.8 V to 3.7 V in 0.1 V step.

\*: The auto discharge function at off state are options as follows.

(A) Auto-discharge function not included, Active-high

(B) Auto-discharge function included, Active-high

## BLOCK DIAGRAMS

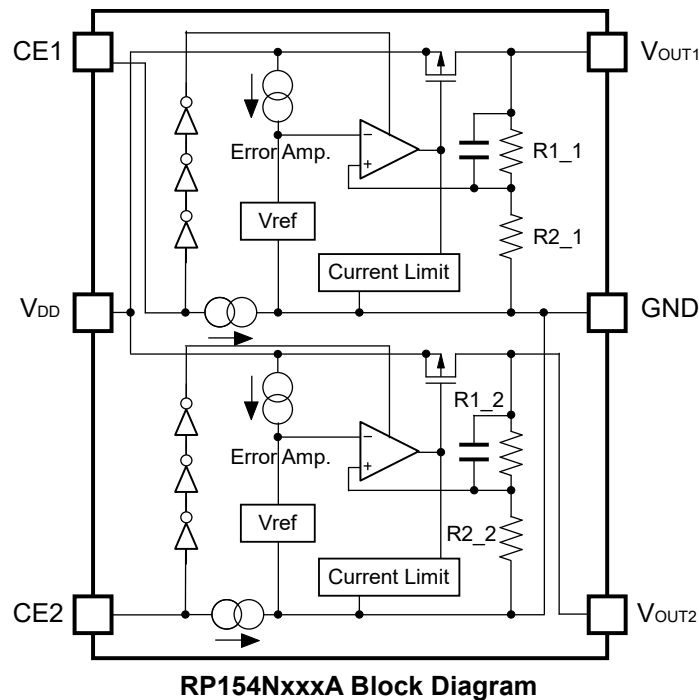

<sup>(1)</sup> Auto-discharge function quickly lowers the output voltage to 0 V by releasing the electrical charge accumulated in the external capacitor when the chip enable signal is switched from the active mode to the standby mode.

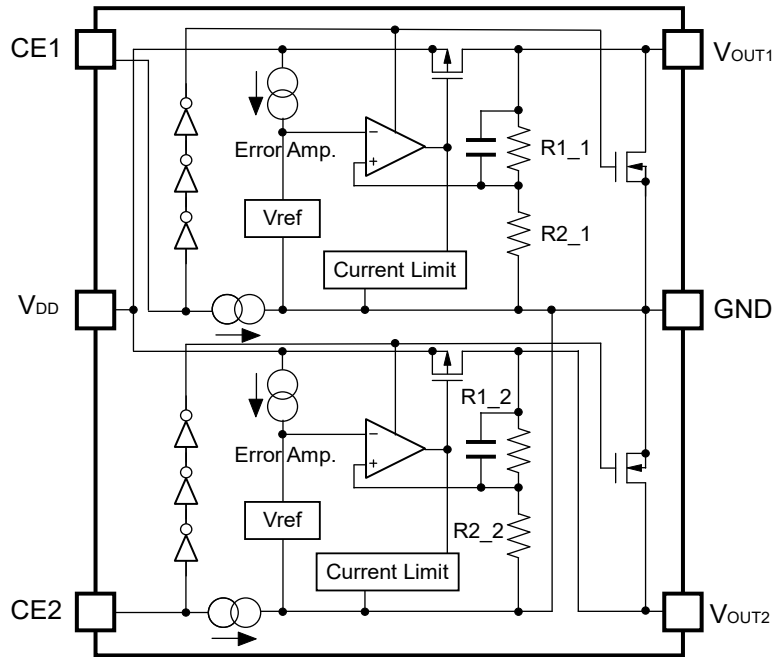

RP154NxxxB Block Diagram

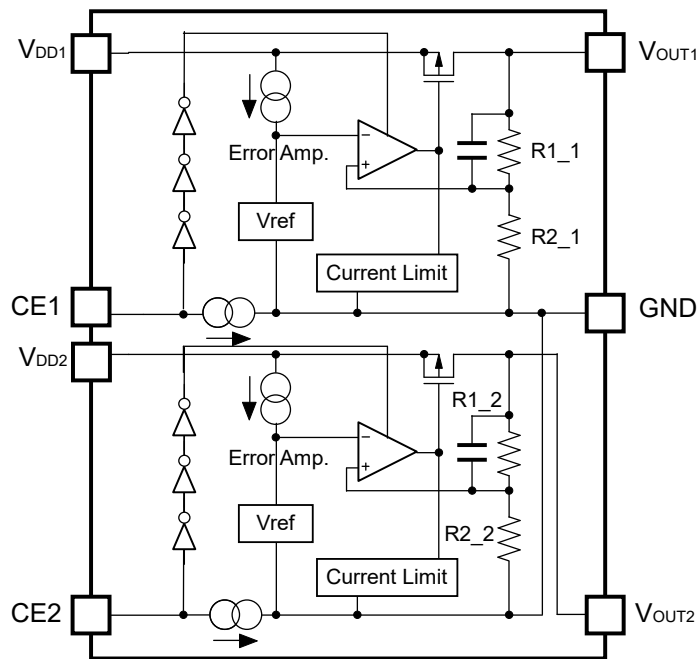

RP154LxxxA Block Diagram

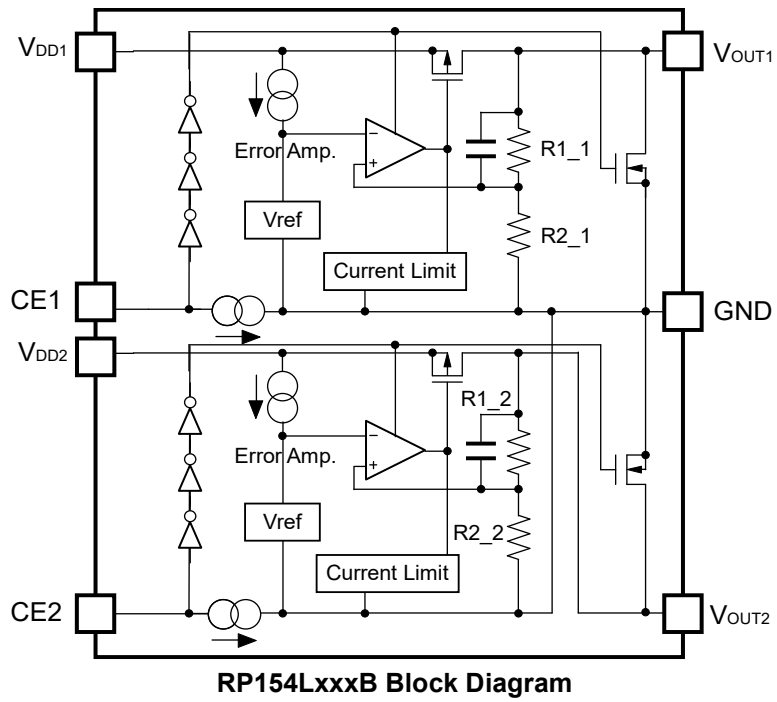

## PIN DESCRIPTIONS

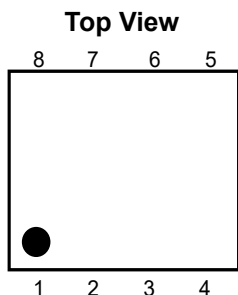

DFN1216-8 Pin Configuration

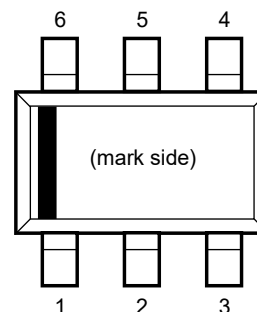
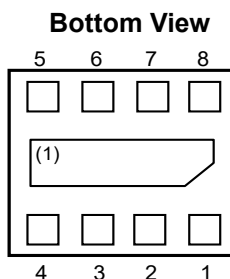

SOT-23-6 Pin Configuration

### DFN1216-8 Pin Description

Pin No.	Symbol	Description
1	GND	Ground Pin <sup>(2)</sup>
2	VOUT1	Output Pin 1
3	VOUT2	Output Pin 2
4	GND	Ground Pin <sup>(2)</sup>
5	CE2	Chip Enable Pin 2, Active-high
6	VDD2	Input Pin
7	VDD1	Input Pin
8	CE1	Chip Enable Pin 1, Active-high

### SOT-23-6 Pin Description

Pin No.	Symbol	Description
1	CE1	Chip Enable Pin 1 ("H" Active)
2	VDD	Input Pin
3	CE2	Chip Enable Pin 2 ("H" Active)
4	VOUT2	Output Pin 2
5	GND	Ground Pin
6	VOUT1	Output Pin 1

<sup>(1)</sup> Tab is GND level. (They are connected to the reverse side of this IC). The tab is better to be connected to the GND, but leaving it open is also acceptable.

<sup>(2)</sup> The GND pin must be wired together when it is mounted on board.

**ABSOLUTE MAXIMUM RATINGS****Absolute Maximum Ratings**

Symbol	Item	Rating	Unit	
$V_{IN}$	Input Voltage	6.0	V	
$V_{CE}$	Input Voltage (CE Pin)	-0.3 to 6.0	V	
$V_{OUT1}, V_{OUT2}$	Output Voltage	-0.3 to $V_{IN} + 0.3$	V	
$I_{OUT1}, I_{OUT2}$	Output Current	400	mA	
$P_D$	Power Dissipation <sup>(1)</sup> (JEDEC STD. 51-7 Test Land Pattern)	DFN1216-8	1700	mW
		SOT-23-6	660	
$P_D$	Power Dissipation (DFN1216-8) <sup>(2)</sup>	625	mW	
	Power Dissipation (SOT-23-6) <sup>(1)</sup>	420		
$T_j$	Junction Temperature Range	-40 to 125	°C	
$T_{stg}$	Storage Temperature Range	-55 to 125	°C	

**ABSOLUTE MAXIMUM RATINGS**

Electronic and mechanical stress momentarily exceeded absolute maximum ratings may cause permanent damage and may degrade the life time and safety for both device and system using the device in the field. The functional operation at or over these absolute maximum ratings is not assured.

**RECOMMENDED OPERATING CONDITIONS****Recommended Operating Conditions**

Symbol	Item	Rating	Unit
$V_{IN}$	Operating Input Voltage	1.4 to 5.25	V
$T_a$	Operating Temperature Range	-40 to 85	°C

**RECOMMENDED OPERATING CONDITIONS**

All of electronic equipment should be designed that the mounted semiconductor devices operate within the recommended operating conditions. The semiconductor devices cannot operate normally over the recommended operating conditions, even if they are used over such conditions by momentary electronic noise or surge. And the semiconductor devices may receive serious damage when they continue to operate over the recommended operating conditions.

<sup>(1)</sup> Refer to *POWER DISSIPATION* for detailed information.

<sup>(2)</sup> Refer to *POWER DISSIPATION* for detailed information.

## ELECTRICAL CHARACTERISTICS

$V_{IN} = V_{SET} > +1.0\text{ V}$  ( $V_{SET} > 1.5\text{ V}$ ),  $V_{IN} = 2.5\text{ V}$  ( $V_{SET} \leq 1.5\text{ V}$ ),  $I_{OUT} = 1\text{ mA}$ ,  $C_{IN} = C_{OUT} = 1.0\text{ }\mu\text{F}$ , unless otherwise noted,

$V_{SET}$  = Set Output Voltage

The specification in    is checked and guaranteed by design engineering at  $-40^{\circ}\text{C} \leq T_a \leq 85^{\circ}\text{C}$ .

### VR1/VR2 Electrical Characteristics

( $T_a = 25^{\circ}\text{C}$ )

Symbol	Item	Conditions	Min.	Typ.	Max.	Unit	
$V_{OUT}$	Output Voltage	$T_a = 25^{\circ}\text{C}$	$V_{SET} > 2.0\text{ V}$	$\times 0.99$		$\times 1.01$	V
			$V_{SET} \leq 2.0\text{ V}$	-20		20	mV
		$-40^{\circ}\text{C} \leq T_a \leq 85^{\circ}\text{C}$	$V_{SET} > 2.0\text{ V}$	<span style="border: 1px solid black; padding: 0 2px;">×0.97</span>		<span style="border: 1px solid black; padding: 0 2px;">×1.03</span>	V
			$V_{SET} \leq 2.0\text{ V}$	<span style="border: 1px solid black; padding: 0 2px;">-60</span>		<span style="border: 1px solid black; padding: 0 2px;">60</span>	mV
$I_{OUT}$	Output Current		<span style="border: 1px solid black; padding: 0 2px;">300</span>			mA	
$\frac{\Delta V_{OUT}}{\Delta I_{OUT}}$	Load Regulation	$1\text{ mA} \leq I_{OUT} \leq 300\text{ mA}$		15	<span style="border: 1px solid black; padding: 0 2px;">40</span>	mV	
$V_{DIF}$	Dropout Voltage	<b>Refer to Dropout Voltage by Set Output Voltage.</b>					
$I_{SS}$	Supply Current	$I_{OUT} = 0\text{ mA}$		50	<span style="border: 1px solid black; padding: 0 2px;">75</span>	$\mu\text{A}$	
$I_{standby}$	Standby Current	$V_{CE} = 0\text{ V}$		0.1	1.0	$\mu\text{A}$	
$\frac{\Delta V_{OUT}}{\Delta V_{IN}}$	Line Regulation	$V_{SET} + 0.5\text{ V} \leq V_{IN} \leq 5.25\text{ V}$ ( $V_{IN} \geq 1.4\text{ V}$ )		0.02	<span style="border: 1px solid black; padding: 0 2px;">0.10</span>	%/V	
RR	Ripple Rejection	$f = 1\text{ kHz}$ , Ripple $0.2\text{ V}_{p-p}$ $V_{IN} = V_{SET} + 1.0\text{ V}$ , $I_{OUT} = 30\text{ mA}$ (When $V_{SET} \leq 2.0\text{ V}$ , $V_{IN} = 3.0\text{ V}$ )		75		dB	
$V_{IN}$	Input Voltage <sup>(1)</sup>		<span style="border: 1px solid black; padding: 0 2px;">1.4</span>		<span style="border: 1px solid black; padding: 0 2px;">5.25</span>	V	
$\frac{\Delta V_{OUT}}{\Delta T_a}$	Output Voltage Temperature Coefficient	$-40^{\circ}\text{C} \leq T_a \leq 85^{\circ}\text{C}$		$\pm 80$		ppm/ $^{\circ}\text{C}$	
$I_{SC}$	Short Current Limit	$V_{OUT} = 0\text{ V}$		60		mA	
$I_{PD}$	CE Pull-down Current			0.3	<span style="border: 1px solid black; padding: 0 2px;">0.6</span>	$\mu\text{A}$	
$V_{CEH}$	CE Input Voltage "H"		<span style="border: 1px solid black; padding: 0 2px;">1.0</span>			V	
$V_{CEL}$	CE Input Voltage "L"				<span style="border: 1px solid black; padding: 0 2px;">0.4</span>	V	
en	Output Noise	$BW = 10\text{ Hz} \sim 100\text{ kHz}$		75		$\mu\text{V}_{rms}$	
$R_{LOW}$	Low Output Nch Tr. ON Resistance (of B version)	$V_{IN} = 4.0\text{ V}$ , $V_{CE} = 0\text{ V}$		50		$\Omega$	

All of unit are tested and specified under load conditions such that  $T_j \approx T_a = 25^{\circ}\text{C}$  except for Output Noise, Ripple Rejection, Output Voltage Temperature Coefficient and Thermal Shutdown.

<sup>(1)</sup> The maximum Input Voltage of *ELECTRICAL CHARACTERISTICS* is 5.25 V. In case of exceeding this specification, the IC must be operated on condition that the Input Voltage is up to 5.5 V and the total operating time is within 500 hrs.

**ELECTRICAL CHARACTERISTICS (continued)**

The specification in  is checked and guaranteed by design engineering at  $-40^{\circ}\text{C} \leq T_a \leq 85^{\circ}\text{C}$ .

**Dropout Voltage by Set Output Voltage**

(Ta = 25°C)

Set Output Voltage $V_{\text{SET}}$ (V)	Dropout Voltage $V_{\text{DIF}}$ (V)		
	Condition	Typ.	Max.
$V_{\text{SET}} = 0.8$	$I_{\text{OUT}} = 300 \text{ mA}$	0.56	<input type="checkbox"/> 0.72
$V_{\text{SET}} = 0.9$		0.51	<input type="checkbox"/> 0.65
$1.0 \leq V_{\text{SET}} < 1.2$		0.46	<input type="checkbox"/> 0.59
$1.2 \leq V_{\text{SET}} < 1.4$		0.39	<input type="checkbox"/> 0.50
$1.4 \leq V_{\text{SET}} < 1.7$		0.35	<input type="checkbox"/> 0.44
$1.7 \leq V_{\text{SET}} < 2.1$		0.30	<input type="checkbox"/> 0.39
$2.1 \leq V_{\text{SET}} < 2.5$		0.26	<input type="checkbox"/> 0.34
$2.5 \leq V_{\text{SET}} < 3.0$		0.25	<input type="checkbox"/> 0.30
$3.0 \leq V_{\text{SET}} \leq 3.7$		0.22	<input type="checkbox"/> 0.29



RP154xxxxx Product-specific Electrical Characteristics

Product Name	VR1								VR2							
	V <sub>OUT</sub> [V] (Ta = 25°C)			V <sub>OUT</sub> [V] (-40°C ≤ Ta ≤ 85°C)			ΔV <sub>DIF</sub> [V]		V <sub>OUT</sub> [V] (Ta = 25°C)			V <sub>OUT</sub> [V] (-40°C ≤ Ta ≤ 85°C)			ΔV <sub>DIF</sub> [V]	
	Min.	Typ.	Max.	Min.	Typ.	Max.	Typ.	Max.	Min.	Typ.	Max.	Min.	Typ.	Max.	Typ.	Max.
RP154x001x	2.772	2.800	2.828	2.716	2.800	2.884	0.25	0.30	2.772	2.800	2.828	2.716	2.800	2.884	0.25	0.30
RP154x002x	1.780	1.800	1.820	1.740	1.800	1.860	0.30	0.39	2.772	2.800	2.828	2.716	2.800	2.884	0.25	0.30
RP154x003x	1.480	1.500	1.520	1.440	1.500	1.560	0.35	0.44	2.772	2.800	2.828	2.716	2.800	2.884	0.25	0.30
RP154x004x	1.180	1.200	1.220	1.140	1.200	1.260	0.39	0.50	1.780	1.800	1.820	1.740	1.800	1.860	0.30	0.39
RP154x005x	3.267	3.300	3.333	3.201	3.300	3.399	0.22	0.29	1.180	1.200	1.220	1.140	1.200	1.260	0.39	0.50
RP154x006x	3.267	3.300	3.333	3.201	3.300	3.399	0.22	0.29	1.780	1.800	1.820	1.740	1.800	1.860	0.30	0.39
RP154x007x	2.822	2.850	2.878	2.765	2.850	2.935	0.25	0.30	2.822	2.850	2.878	2.765	2.850	2.935	0.25	0.30
RP154x008x	2.822	2.850	2.878	2.765	2.850	2.935	0.25	0.30	2.574	2.600	2.626	2.522	2.600	2.678	0.25	0.30
RP154x009x	2.970	3.000	3.030	2.910	3.000	3.090	0.22	0.29	2.772	2.800	2.828	2.716	2.800	2.884	0.25	0.30
RP154x010x	2.970	3.000	3.030	2.910	3.000	3.090	0.22	0.29	1.780	1.800	1.820	1.740	1.800	1.860	0.30	0.39
RP154x011x	1.780	1.800	1.820	1.740	1.800	1.860	0.30	0.39	1.480	1.500	1.520	1.440	1.500	1.560	0.35	0.44
RP154x012x	2.772	2.800	2.828	2.716	2.800	2.884	0.25	0.30	2.574	2.600	2.626	2.522	2.600	2.678	0.25	0.30
RP154x013x	3.267	3.300	3.333	3.201	3.300	3.399	0.22	0.29	2.772	2.800	2.828	2.716	2.800	2.884	0.25	0.30
RP154x014x	3.267	3.300	3.333	3.201	3.300	3.399	0.22	0.29	3.267	3.300	3.333	3.201	3.300	3.399	0.22	0.29
RP154x015x	1.480	1.500	1.520	1.440	1.500	1.560	0.35	0.44	2.475	2.500	2.525	2.425	2.500	2.575	0.25	0.30
RP154x016x	1.480	1.500	1.520	1.440	1.500	1.560	0.35	0.44	2.970	3.000	3.030	2.910	3.000	3.090	0.22	0.29
RP154x017x	2.475	2.500	2.525	2.425	2.500	2.575	0.25	0.30	2.970	3.000	3.030	2.910	3.000	3.090	0.22	0.29
RP154x018x	1.780	1.800	1.820	1.740	1.800	1.860	0.30	0.39	1.780	1.800	1.820	1.740	1.800	1.860	0.30	0.39
RP154x019x	1.480	1.500	1.520	1.440	1.500	1.560	0.35	0.44	2.574	2.600	2.626	2.522	2.600	2.678	0.25	0.30
RP154x020x	2.772	2.800	2.828	2.716	2.800	2.884	0.25	0.30	1.780	1.800	1.820	1.740	1.800	1.860	0.30	0.39
RP154x021x	1.180	1.200	1.220	1.140	1.200	1.260	0.39	0.50	2.772	2.800	2.828	2.716	2.800	2.884	0.25	0.30
RP154x022x	2.772	2.800	2.828	2.716	2.800	2.884	0.25	0.30	1.180	1.200	1.220	1.140	1.200	1.260	0.39	0.50
RP154x023x	2.475	2.500	2.525	2.425	2.500	2.575	0.25	0.30	2.475	2.500	2.525	2.425	2.500	2.575	0.25	0.30
RP154x024x	3.267	3.300	3.333	3.201	3.300	3.399	0.22	0.29	2.970	3.000	3.030	2.910	3.000	3.090	0.22	0.29
RP154x025x	2.970	3.000	3.030	2.910	3.000	3.090	0.22	0.29	2.970	3.000	3.030	2.910	3.000	3.090	0.22	0.29

# RP154x

No. EA-202-210715

## RP154xxxx Product-specific Electrical Characteristics

Product Name	VR1								VR2							
	V <sub>OUT</sub> [V] (Ta = 25°C)			V <sub>OUT</sub> [V] (-40°C ≤ Ta ≤ 85°C)			ΔV <sub>DIF</sub> [V]		V <sub>OUT</sub> [V] (Ta = 25°C)			V <sub>OUT</sub> [V] (-40°C ≤ Ta ≤ 85°C)			ΔV <sub>DIF</sub> [V]	
	Min.	Typ.	Max.	Min.	Typ.	Max.	Typ.	Max.	Min.	Typ.	Max.	Min.	Typ.	Max.	Typ.	Max.
RP154x026x	2.772	2.800	2.828	2.716	2.800	2.884	0.25	0.30	3.069	3.100	3.131	3.007	3.100	3.193	0.22	0.29
RP154x027x	2.277	2.300	2.323	2.231	2.300	2.369	0.26	0.34	2.772	2.800	2.828	2.716	2.800	2.884	0.25	0.30
RP154x028x	2.772	2.800	2.828	2.716	2.800	2.884	0.25	0.30	0.980	1.000	1.020	0.940	1.000	1.060	0.46	0.59
RP154x029x	1.480	1.500	1.520	1.440	1.500	1.560	0.35	0.44	1.480	1.500	1.520	1.440	1.500	1.560	0.35	0.44
RP154x030x	1.180	1.200	1.220	1.140	1.200	1.260	0.39	0.50	2.871	2.900	2.929	2.813	2.900	2.987	0.25	0.30
RP154x031x	2.624	2.650	2.676	2.571	2.650	2.729	0.25	0.30	2.822	2.850	2.878	2.765	2.850	2.935	0.25	0.30
RP154x032x	3.267	3.300	3.333	3.201	3.300	3.399	0.22	0.29	2.822	2.850	2.878	2.765	2.850	2.935	0.25	0.30
RP154x033x	1.780	1.800	1.820	1.740	1.800	1.860	0.30	0.39	2.871	2.900	2.929	2.813	2.900	2.987	0.25	0.30
RP154x034x	3.069	3.100	3.131	3.007	3.100	3.193	0.22	0.29	3.069	3.100	3.131	3.007	3.100	3.193	0.22	0.29
RP154x035x	2.772	2.800	2.828	2.716	2.800	2.884	0.25	0.30	2.673	2.700	2.727	2.619	2.700	2.781	0.25	0.30
RP154x036x	0.980	1.000	1.020	0.940	1.000	1.060	0.46	0.59	1.780	1.800	1.820	1.740	1.800	1.860	0.30	0.39
RP154x037x	1.180	1.200	1.220	1.140	1.200	1.260	0.39	0.50	2.475	2.500	2.525	2.425	2.500	2.575	0.25	0.30
RP154x038x	1.680	1.700	1.720	1.640	1.700	1.760	0.30	0.39	3.069	3.100	3.131	3.007	3.100	3.193	0.22	0.29
RP154x039x	1.780	1.800	1.820	1.740	1.800	1.860	0.30	0.39	2.475	2.500	2.525	2.425	2.500	2.575	0.25	0.30
RP154x040x	1.480	1.500	1.520	1.440	1.500	1.560	0.35	0.44	1.780	1.800	1.820	1.740	1.800	1.860	0.30	0.39
RP154x041x	1.780	1.800	1.820	1.740	1.800	1.860	0.30	0.39	2.673	2.700	2.727	2.619	2.700	2.781	0.25	0.30
RP154x042x	2.673	2.700	2.727	2.619	2.700	2.781	0.25	0.30	2.673	2.700	2.727	2.619	2.700	2.781	0.25	0.30
RP154x043x	2.871	2.900	2.929	2.813	2.900	2.987	0.25	0.30	2.871	2.900	2.929	2.813	2.900	2.987	0.25	0.30
RP154x044x	1.680	1.700	1.720	1.640	1.700	1.760	0.30	0.39	2.970	3.000	3.030	2.910	3.000	3.090	0.22	0.29
RP154x045x	1.730	1.750	1.770	1.690	1.750	1.810	0.30	0.39	2.970	3.000	3.030	2.910	3.000	3.090	0.22	0.29
RP154x046x	2.970	3.000	3.030	2.910	3.000	3.090	0.22	0.29	3.069	3.100	3.131	3.007	3.100	3.193	0.22	0.29
RP154x047x	1.730	1.750	1.770	1.690	1.750	1.810	0.30	0.39	3.069	3.100	3.131	3.007	3.100	3.193	0.22	0.29
RP154x048x	1.780	1.800	1.820	1.740	1.800	1.860	0.30	0.39	3.069	3.100	3.131	3.007	3.100	3.193	0.22	0.29
RP154x049x	2.475	2.500	2.525	2.425	2.500	2.575	0.25	0.30	3.069	3.100	3.131	3.007	3.100	3.193	0.22	0.29
RP154x050x	3.069	3.100	3.131	3.007	3.100	3.193	0.22	0.29	3.267	3.300	3.333	3.201	3.300	3.399	0.22	0.29

RP154xxxxx Product-specific Electrical Characteristics

Product Name	VR1								VR2							
	V <sub>OUT</sub> [V] (Ta = 25°C)			V <sub>OUT</sub> [V] (-40°C ≤ Ta ≤ 85°C)			ΔV <sub>DIF</sub> [V]		V <sub>OUT</sub> [V] (Ta = 25°C)			V <sub>OUT</sub> [V] (-40°C ≤ Ta ≤ 85°C)			ΔV <sub>DIF</sub> [V]	
	Min.	Typ.	Max.	Min.	Typ.	Max.	Typ.	Max.	Min.	Typ.	Max.	Min.	Typ.	Max.	Typ.	Max.
RP154x051x	3.564	3.600	3.636	3.492	3.600	3.708	0.22	0.29	3.564	3.600	3.636	3.492	3.600	3.708	0.22	0.29
RP154x052x	1.780	1.800	1.820	1.740	1.800	1.860	0.30	0.39	2.970	3.000	3.030	2.910	3.000	3.090	0.22	0.29
RP154x053x	2.822	2.850	2.878	2.765	2.850	2.935	0.25	0.30	3.069	3.100	3.131	3.007	3.100	3.193	0.22	0.29
RP154x054x	1.180	1.200	1.220	1.140	1.200	1.260	0.39	0.50	1.180	1.200	1.220	1.140	1.200	1.260	0.39	0.50
RP154x055x	3.663	3.700	3.737	3.589	3.700	3.811	0.22	0.29	3.663	3.700	3.737	3.589	3.700	3.811	0.22	0.29
RP154x056x	1.080	1.100	1.120	1.040	1.100	1.160	0.46	0.59	1.780	1.800	1.820	1.740	1.800	1.860	0.30	0.39
RP154x057x	1.080	1.100	1.120	1.040	1.100	1.160	0.46	0.59	1.180	1.200	1.220	1.140	1.200	1.260	0.39	0.50
RP154x058x	0.980	1.000	1.020	0.940	1.000	1.060	0.46	0.59	3.267	3.300	3.333	3.201	3.300	3.399	0.22	0.29
RP154x059x	0.880	0.900	0.920	0.840	0.900	0.960	0.51	0.65	1.780	1.800	1.820	1.740	1.800	1.860	0.30	0.39
RP154x060x	0.880	0.900	0.920	0.840	0.900	0.960	0.51	0.65	0.880	0.900	0.920	0.840	0.900	0.960	0.51	0.65
RP154x061x	1.180	1.200	1.220	1.140	1.200	1.260	0.39	0.50	2.970	3.000	3.030	2.910	3.000	3.090	0.22	0.29
RP154x062x	2.772	2.800	2.828	2.716	2.800	2.884	0.25	0.30	2.871	2.900	2.929	2.813	2.900	2.987	0.25	0.30
RP154x063x	3.267	3.300	3.333	3.201	3.300	3.399	0.22	0.29	1.480	1.500	1.520	1.440	1.500	1.560	0.35	0.44
RP154x064x	1.080	1.100	1.120	1.040	1.100	1.160	0.46	0.59	2.871	2.900	2.929	2.813	2.900	2.987	0.25	0.30
RP154x065x	2.772	2.800	2.828	2.716	2.800	2.884	0.25	0.30	2.475	2.500	2.525	2.425	2.500	2.575	0.25	0.30
RP154x066x	0.780	0.800	0.820	0.740	0.800	0.860	0.56	0.72	1.780	1.800	1.820	1.740	1.800	1.860	0.30	0.39
RP154x067x	3.267	3.300	3.333	3.201	3.300	3.399	0.22	0.29	2.475	2.500	2.525	2.425	2.500	2.575	0.25	0.30
RP154x068x	1.280	1.300	1.320	1.240	1.300	1.360	0.39	0.50	1.780	1.800	1.820	1.740	1.800	1.860	0.30	0.39
RP154x069x	1.680	1.700	1.720	1.640	1.700	1.760	0.30	0.39	1.480	1.500	1.520	1.440	1.500	1.560	0.35	0.44
RP154x070x	1.180	1.200	1.220	1.140	1.200	1.260	0.39	0.50	1.280	1.300	1.320	1.240	1.300	1.360	0.39	0.50
RP154x071x	1.080	1.100	1.120	1.040	1.100	1.160	0.46	0.59	3.267	3.300	3.333	3.201	3.300	3.399	0.22	0.29

**APPLICATION INFORMATION**

**TYPICAL APPLICATION CIRCUIT**

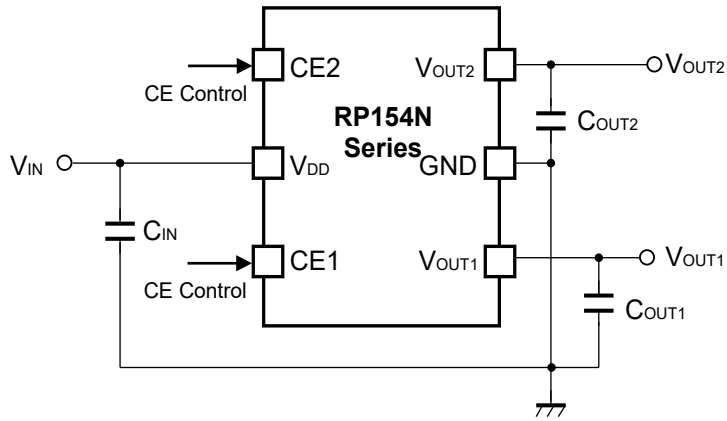

$C_{IN} = C_{OUT1} = C_{OUT2} = \text{Ceramic } 1.0 \mu\text{F}$   
**RP154NxxxA/B Typical Application Circuit**

**External Components**

Symbol	Description
$C_{OUT1}, C_{OUT2}$	Ceramic Capacitor, 1.0 $\mu\text{F}$ , Murata: GRM155B31A105KE15

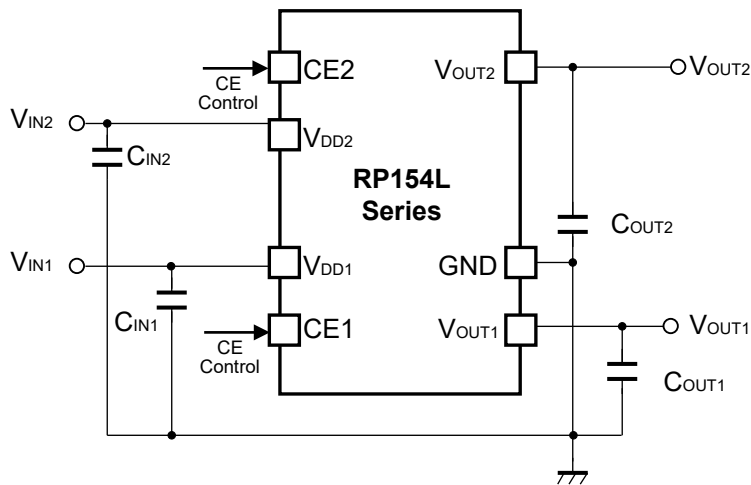

$C_{IN1} = C_{IN2} = C_{OUT1} = C_{OUT2} = \text{Ceramic } 1.0 \mu\text{F}$   
**RP154LxxxA/B Typical Application Circuit**

**External Components**

Symbol	Description
$C_{OUT1}, C_{OUT2}$	Ceramic Capacitor, 1.0 $\mu\text{F}$ , Murata: GRM155B31A105KE15

## TECHNICAL NOTES

### Phase Compensation

In these ICs, phase compensation is made for securing stable operation even if the load current is varied. For this purpose, use capacitors (1.0  $\mu$ F or more) for  $C_{OUT1}$  and  $C_{OUT2}$  with good frequency characteristics and ESR (Equivalent Series Resistance).

Note: If additional ceramic capacitors are connected with parallel to the output pin with an output capacitor for phase compensation, the operation might be unstable. Because of this, test these ICs with as same external components as ones to be used on the PCB. If the tantalum capacitor is used and its ESR (Equivalent Series Resistance) is too large, the output may be unstable, therefore, fully evaluation is necessary.

### PCB Layout

Make VDD and GND lines sufficient. If their impedance is high, noise pickup or unstable operation may result. Connect capacitors with a capacitance value as much as 1.0  $\mu$ F or more between VDD and GND pin, and as close as possible to the pins ( $C_{IN1}$ /  $C_{IN2}$ ).

Set external components, especially the output capacitors, as close as possible to the ICs, and make wiring as short as possible ( $C_{OUT1}$ /  $C_{OUT2}$ ).

## TYPICAL CHARACTERISTICS

Note: Typical Characteristics are intended to be used as reference data; they are not guaranteed.

### 1) Output Voltage vs. Output Current ( $C_{IN} = 1.0 \mu F$ , $C_{OUT1} = C_{OUT2} = 1.0 \mu F$ , $T_a = 25^\circ C$ )

0.8V (VR1/VR2)

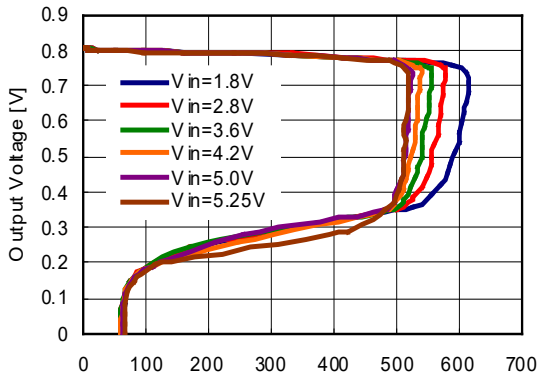

2.5V (VR1/VR2)

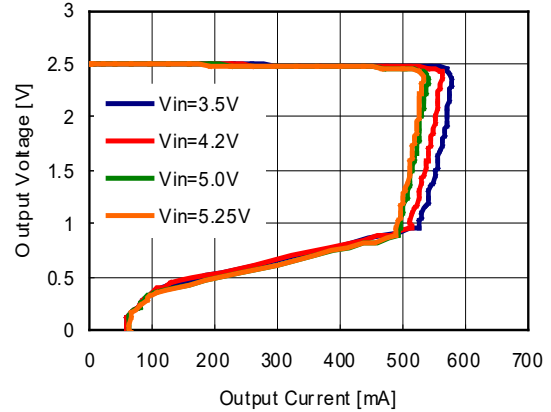

3.6V (VR1/VR2)

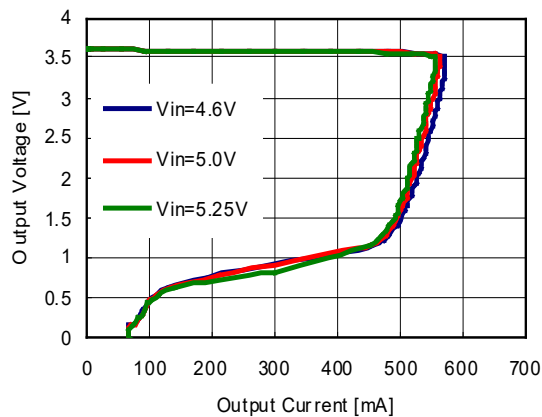

### 2) Output Voltage vs. Input Voltage ( $C_{IN} = 1.0 \mu F$ , $C_{OUT1} = C_{OUT2} = 1.0 \mu F$ , $T_a = 25^\circ C$ )

0.8V (VR1/VR2)

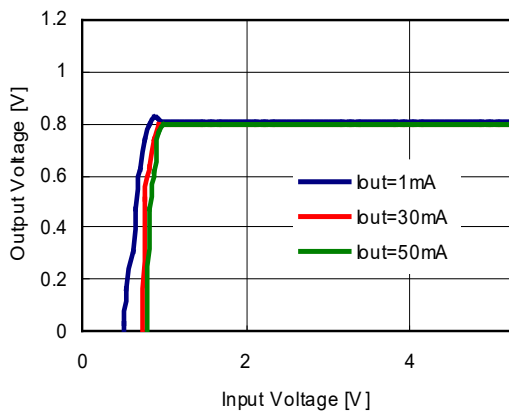

2.5V (VR1/VR2)

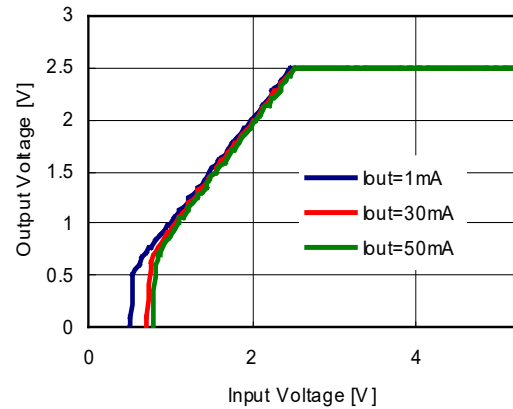

3.6V(VR1/VR2)

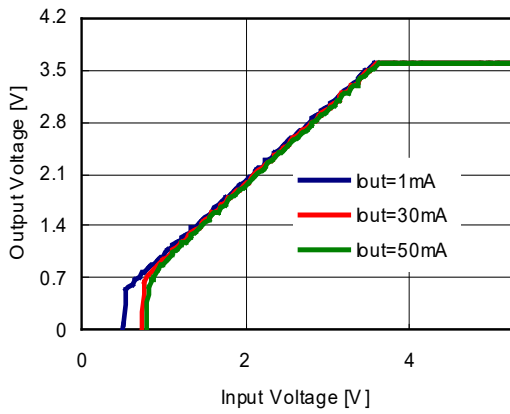

3) Supply Current vs. Input Voltage ( $C_{IN} = 1.0 \mu F$ ,  $C_{OUT1} = C_{OUT2} = 1.0 \mu F$ ,  $T_a = 25^\circ C$ )

0.8V(VR1/VR2)

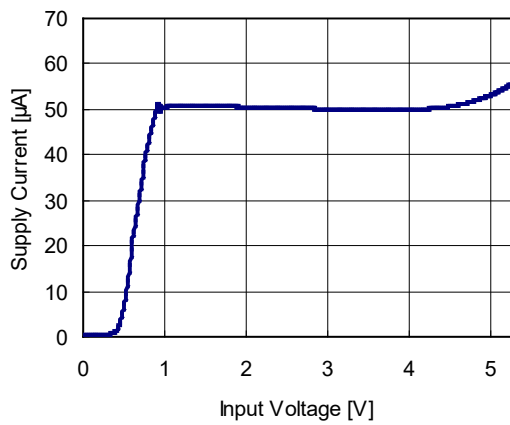

2.5V(VR1/VR2)

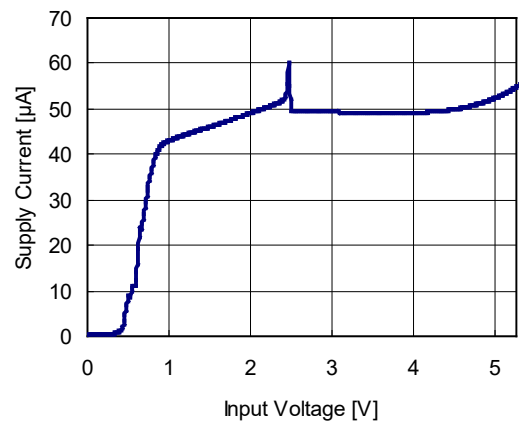

3.6V(VR1/VR2)

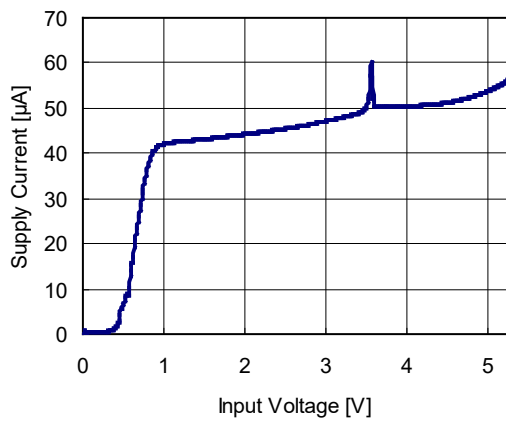

4) Output Voltage vs. Temperature ( $C_{IN} = 1.0 \mu F$ ,  $C_{OUT1} = C_{OUT2} = 1.0 \mu F$ ,  $I_{OUT} = 5 \text{ mA}$ )

0.8V(VR1/VR2)

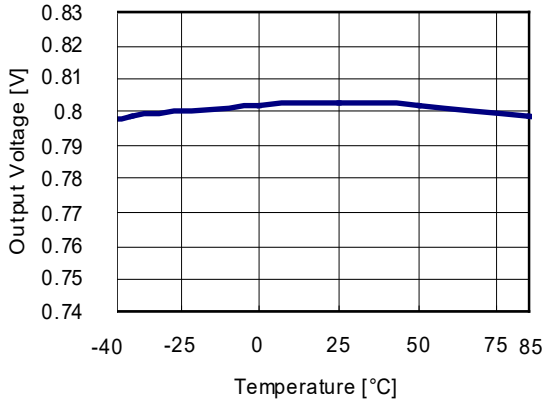

2.5V(VR1/VR2)

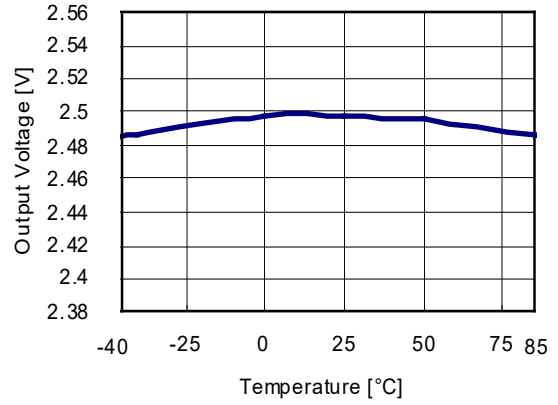

3.6V(VR1/VR2)

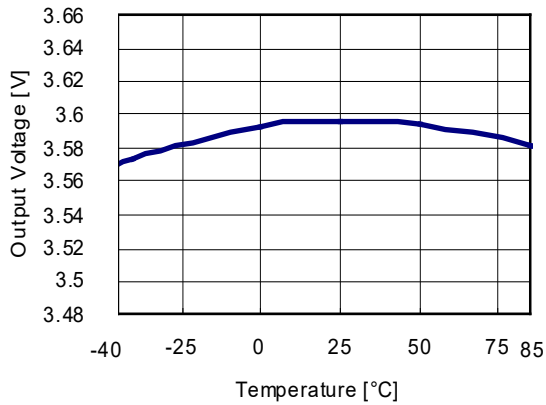

5) Supply Current vs. Temperature ( $C_{IN} = 1.0 \mu F$ ,  $C_{OUT1} = C_{OUT2} = 1.0 \mu F$ )

0.8V(VR1/VR2)

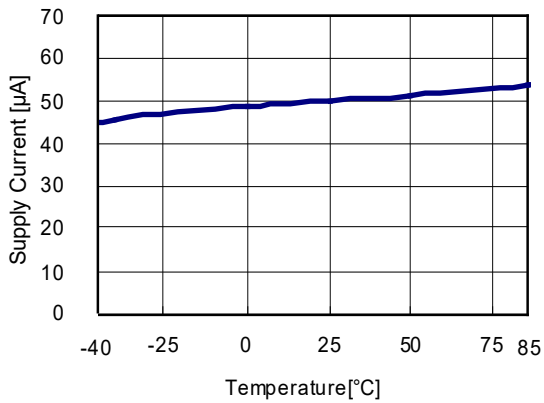

2.5V(VR1/VR2)

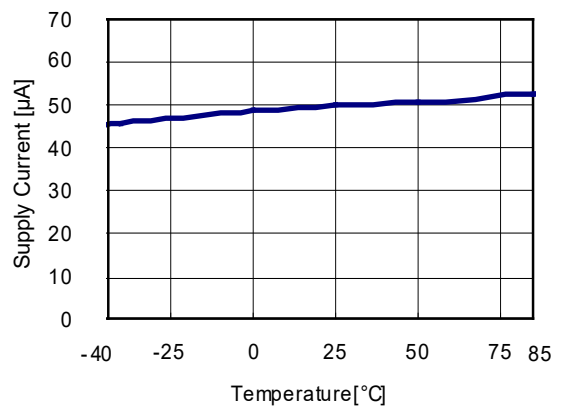



3.6V(VR1/VR2)

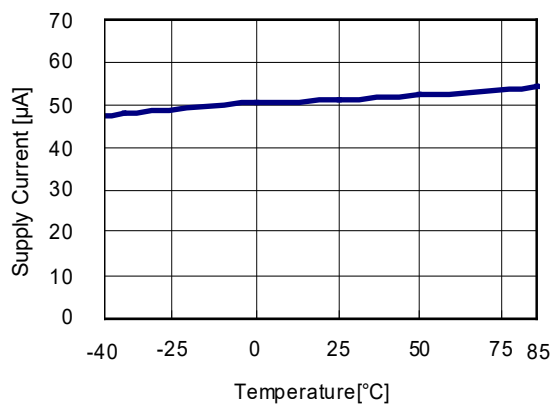

6) Dropout Voltage vs. Output Current ( $C_{IN} = 1.0 \mu F, C_{OUT1} = C_{OUT2} = 1.0 \mu F$ )

0.8V(VR1/VR2)

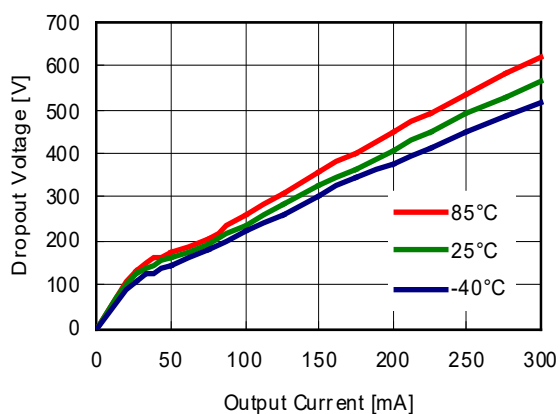

2.5V(VR1/VR2)

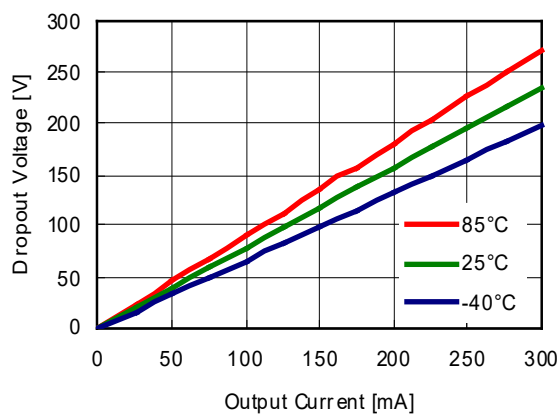

3.6V(VR1/VR2)

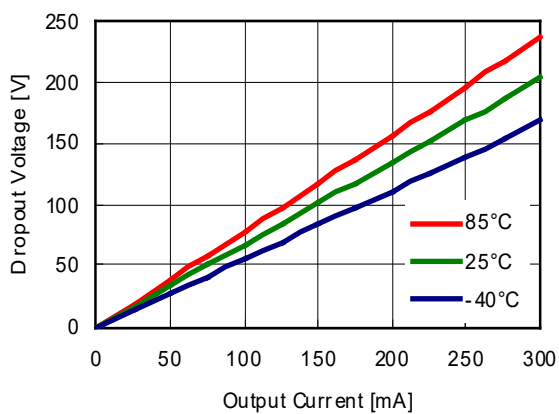

7) Dropout Voltage vs. Set Output Voltage

(VR1/VR2)

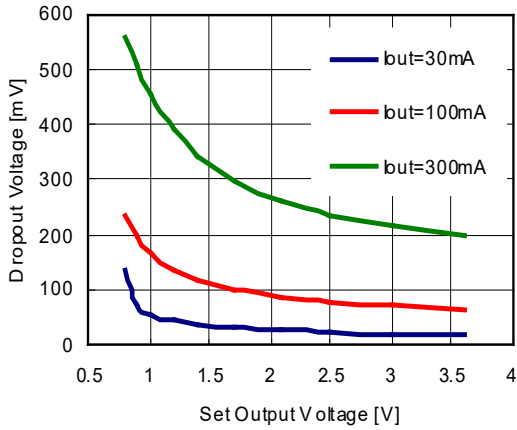

8) Ripple Rejection vs. Input Voltage (C<sub>IN</sub> = none, C<sub>OUT1</sub> = C<sub>OUT2</sub> = 1.0 μF, Ripple = 0.2 Vp-p, Ta = 25°C)

2.5V(VR1/VR2)

I<sub>out</sub>=1mA

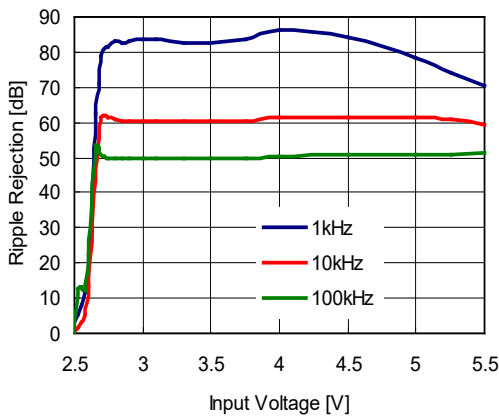

2.5V(VR1/VR2)

I<sub>out</sub>=30mA

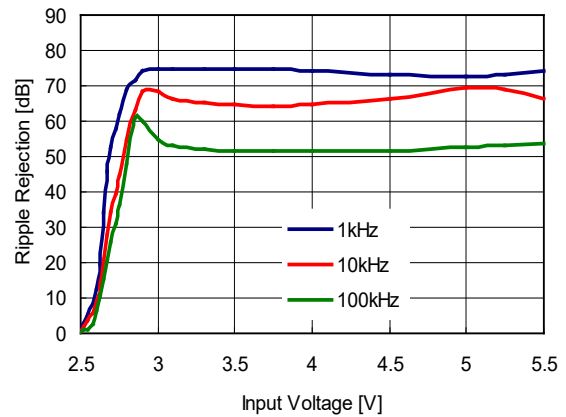

9) Ripple Rejection vs. Frequency (C<sub>IN</sub> = none, C<sub>OUT1</sub> = C<sub>OUT2</sub> = 1.0 μF, Ta = 25°C)

0.8V(VR1/VR2)

V<sub>in</sub>=3V

Ripple=0.2Vp-p

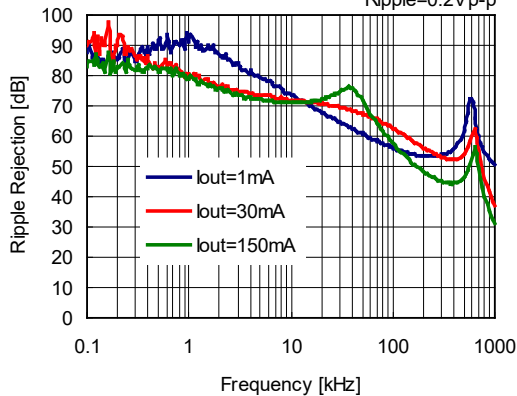

2.5V(VR1/VR2)

V<sub>in</sub>=Set V<sub>out</sub>+1V

Ripple=0.2Vp-p

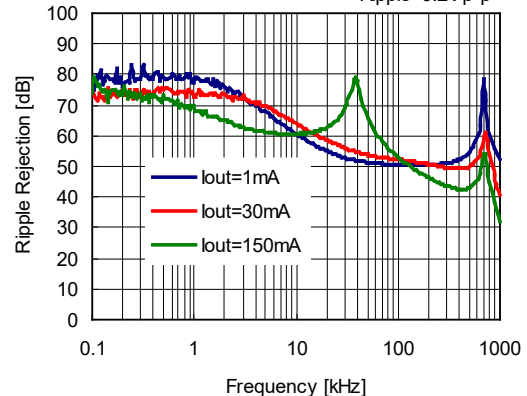

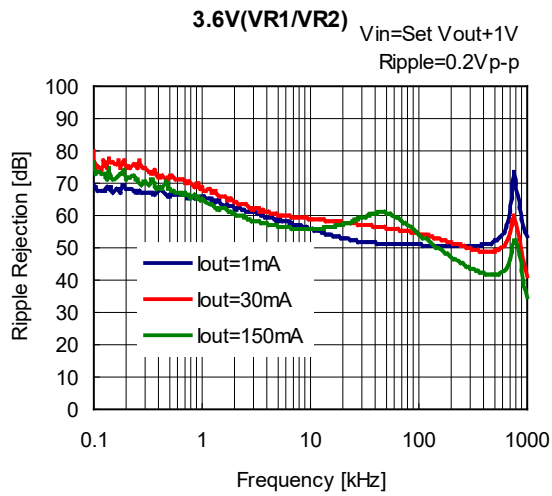

**10) Input Transient Response ( $C_{IN} = \text{none}$ ,  $C_{OUT1} = C_{OUT2} = 1.0 \mu F$ ,  $t_r = t_f = 5 \mu s$ ,  $T_a = 25^\circ C$ )**

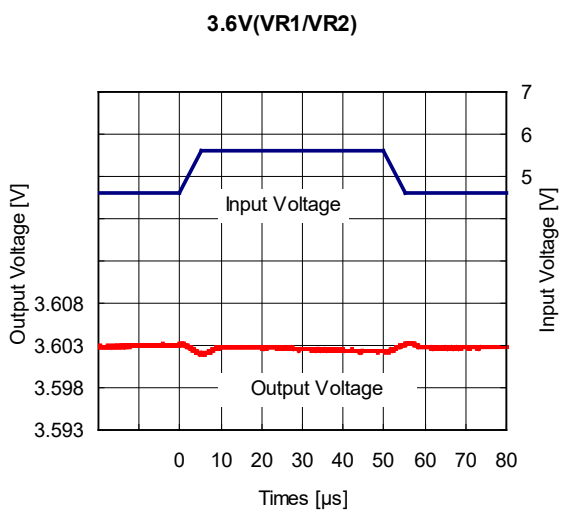
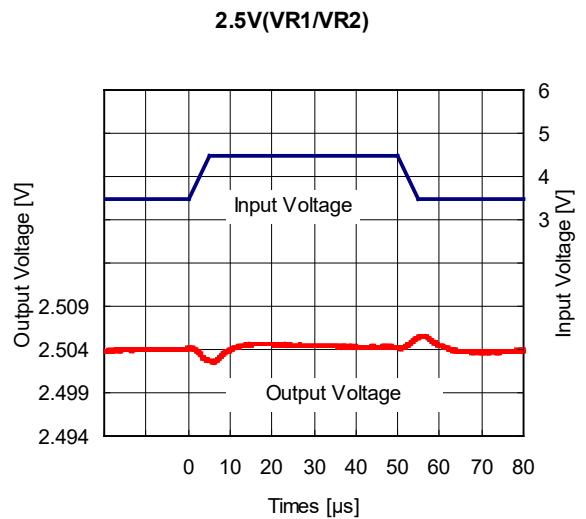
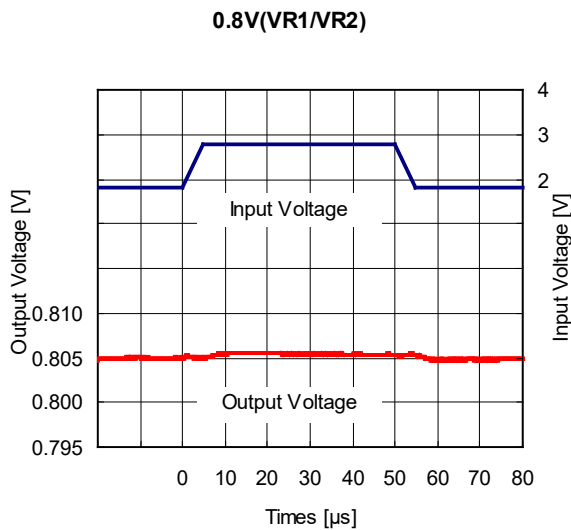

11) Load Transient Response ( $C_{IN} = 1.0 \mu F$ ,  $C_{OUT1} = C_{OUT2} = 1.0 \mu F$ ,  $t_r = t_f = 0.5 \mu s$ ,  $T_a = 25^\circ C$ )

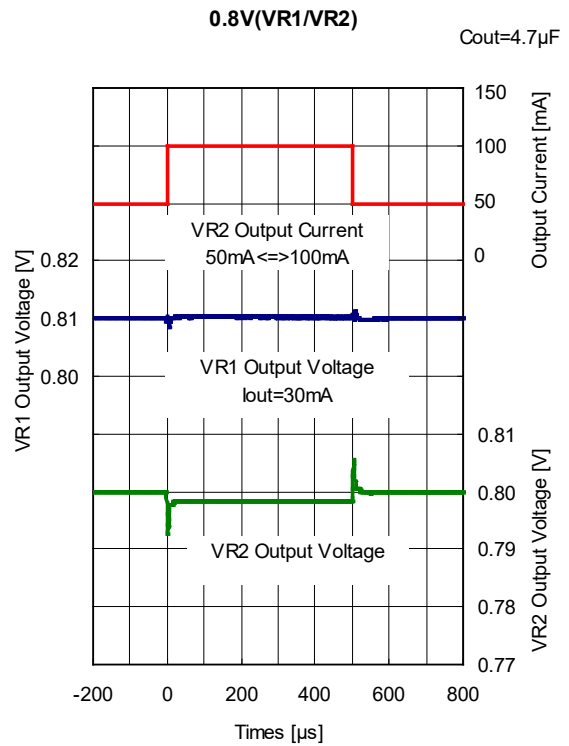
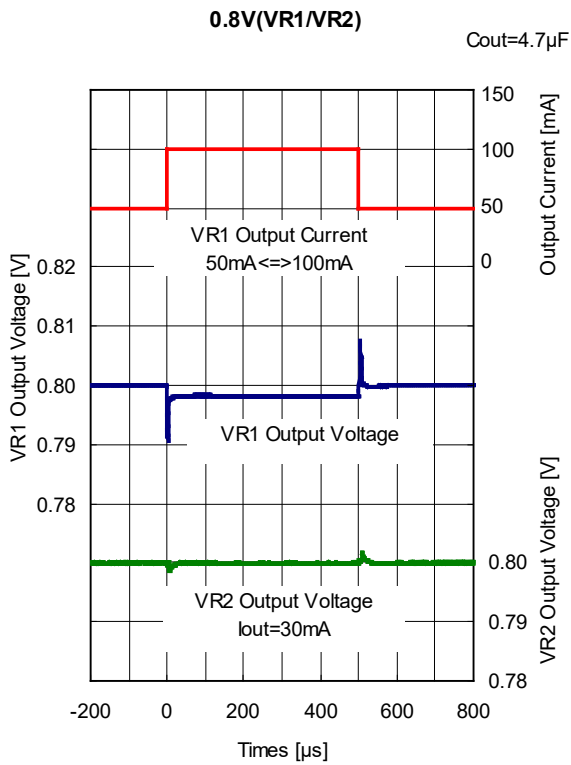
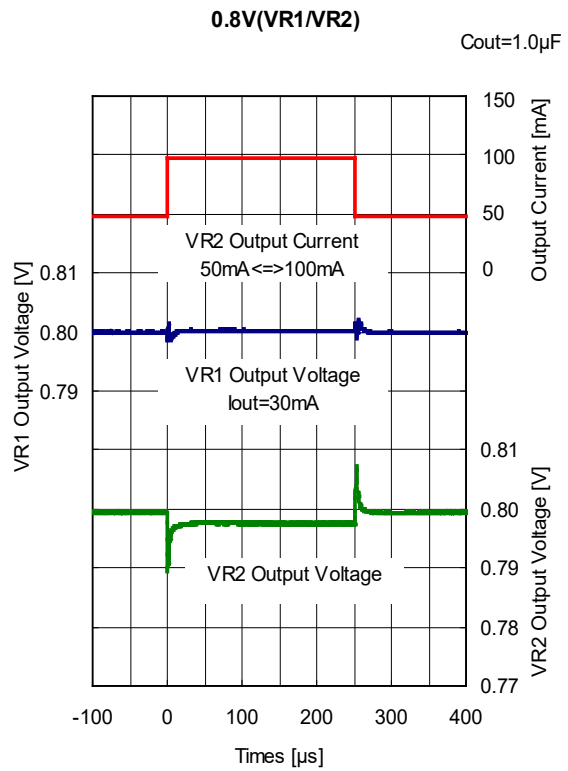
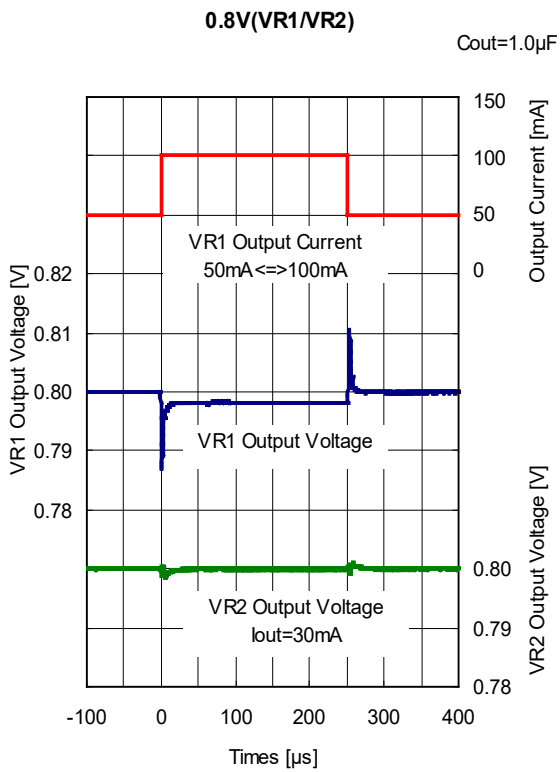

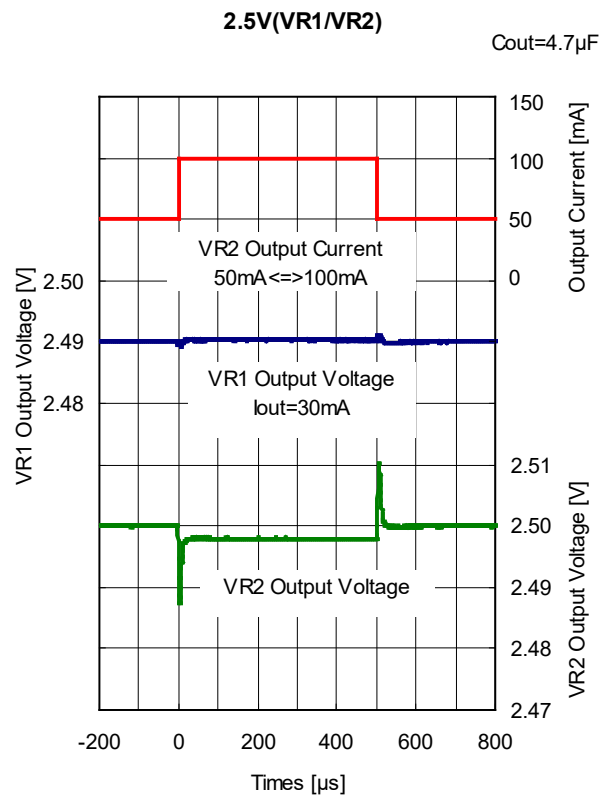
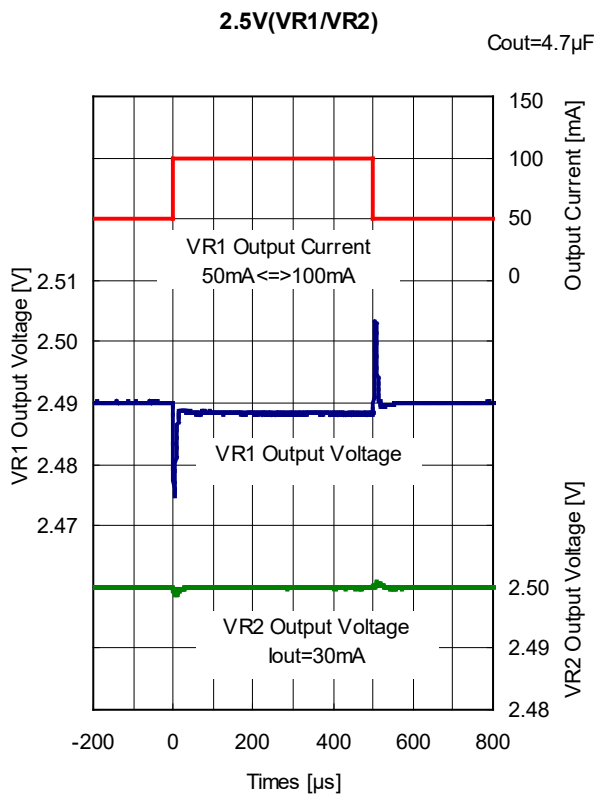
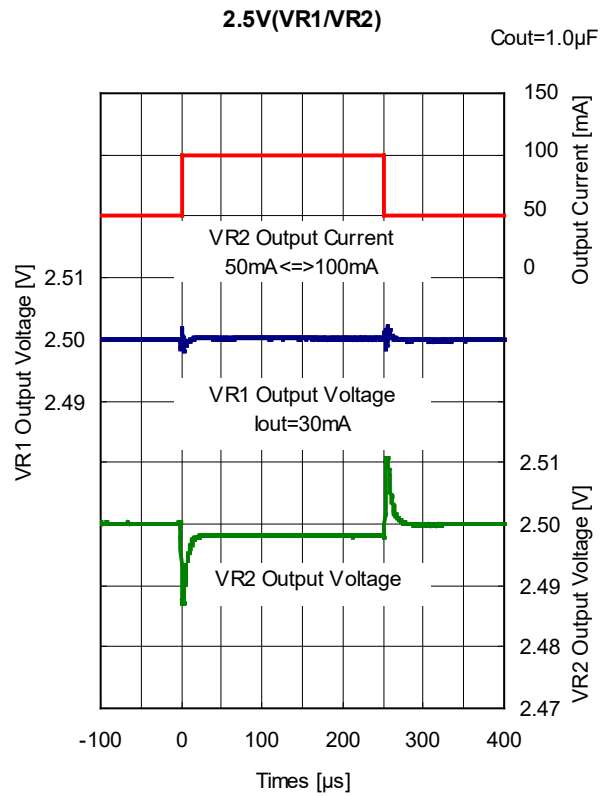
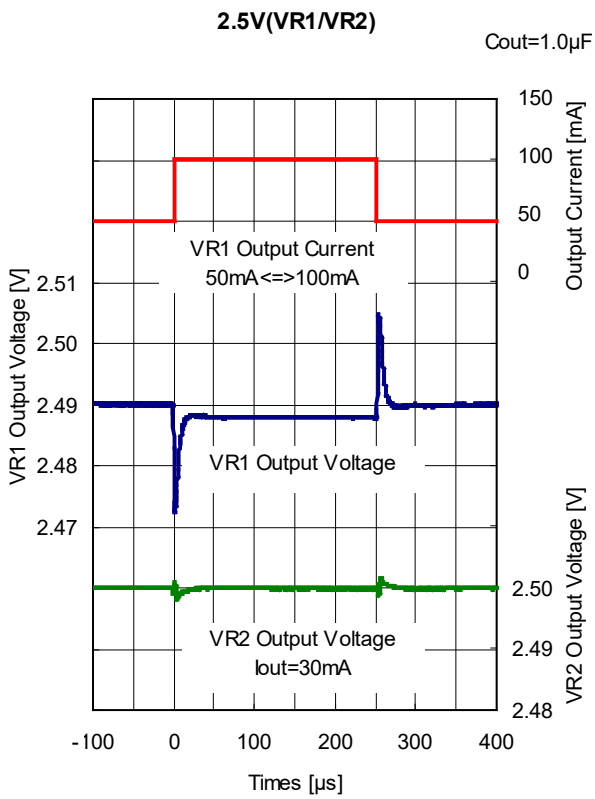

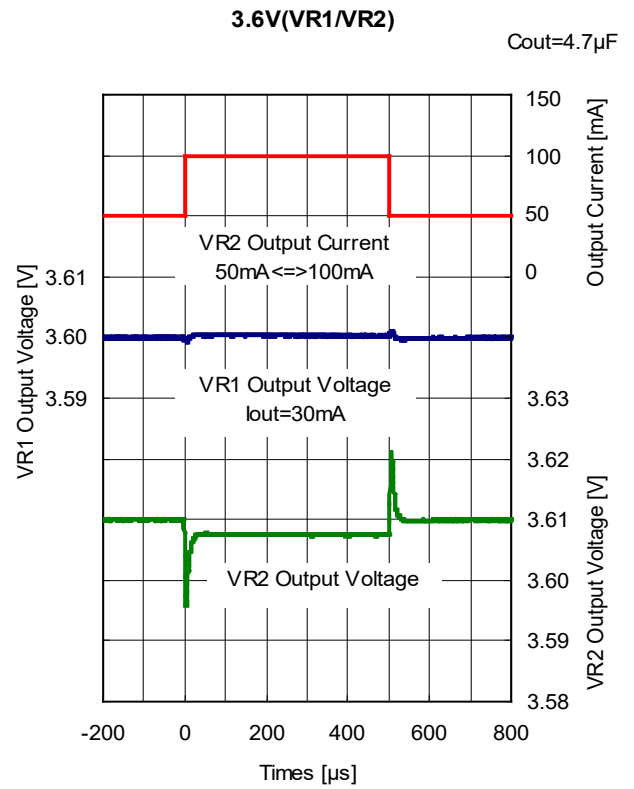
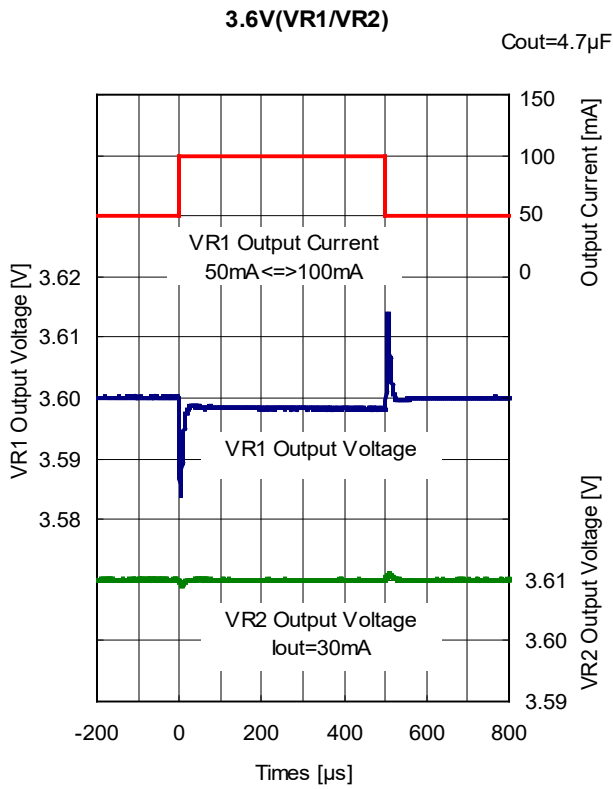
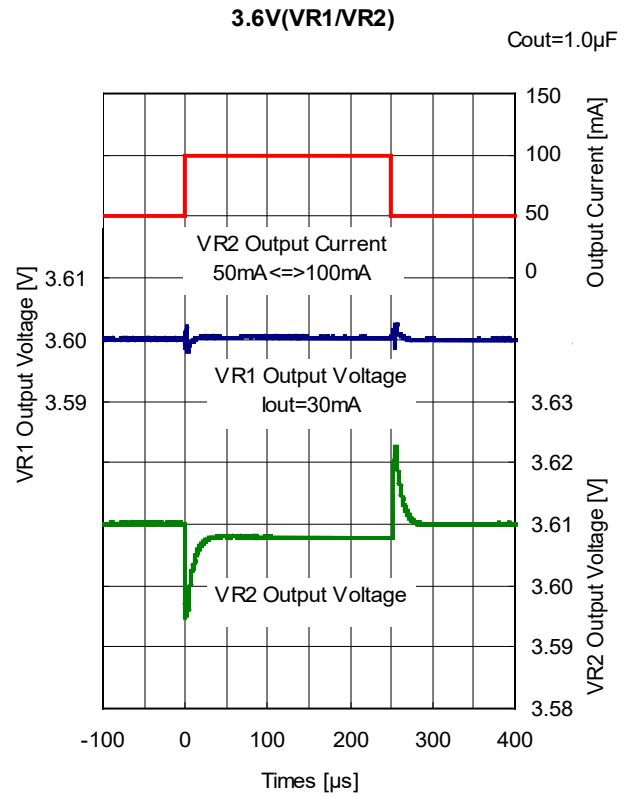
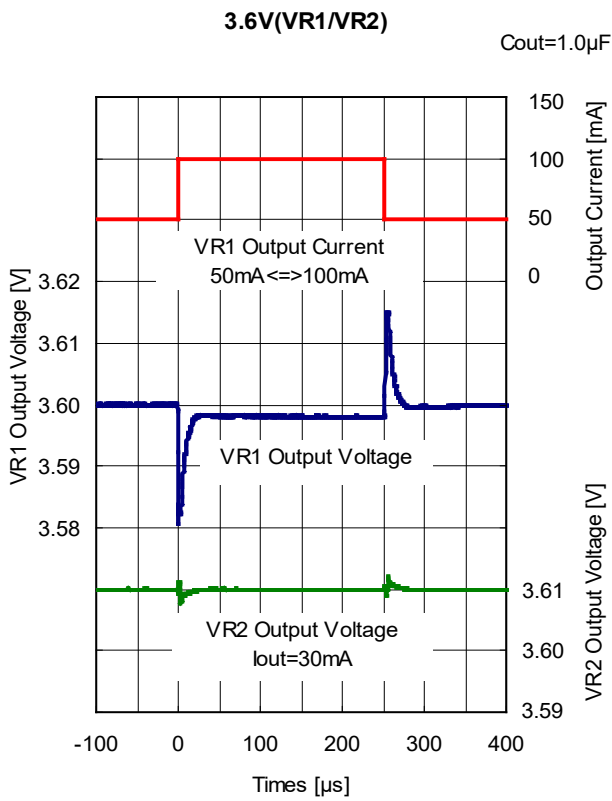

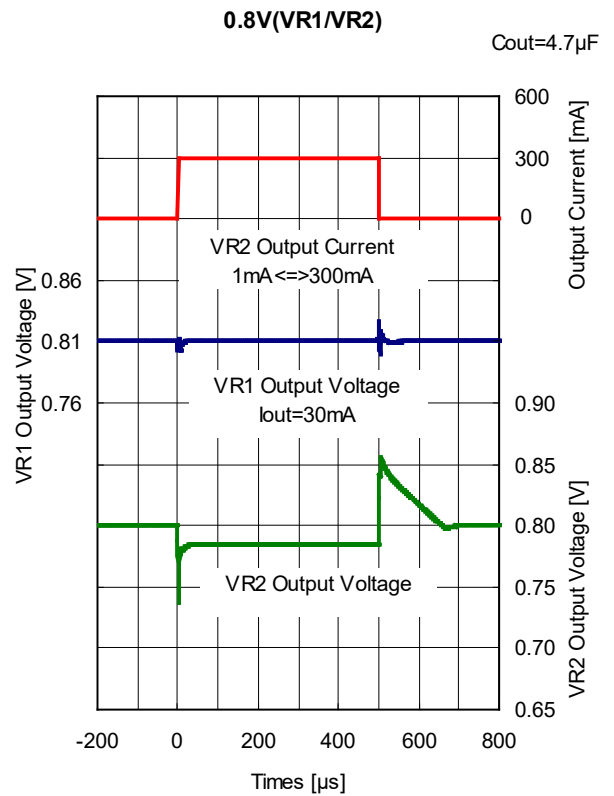
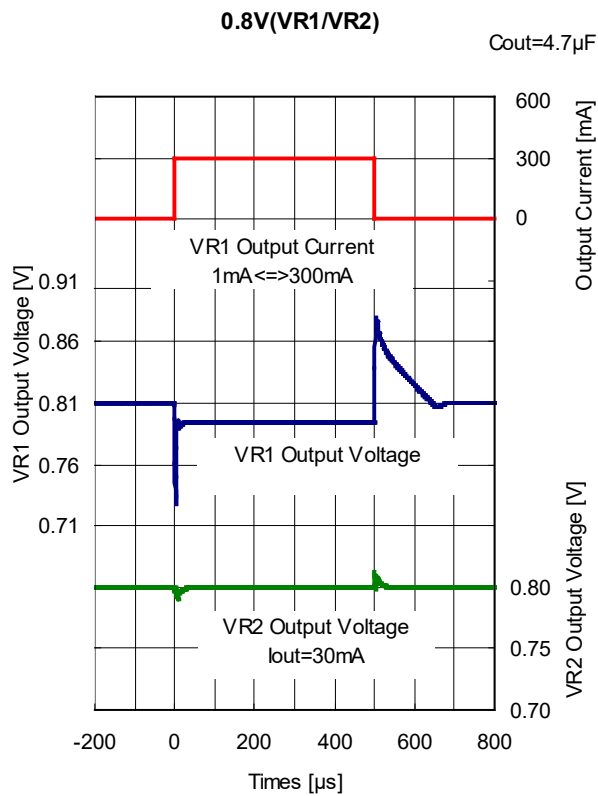
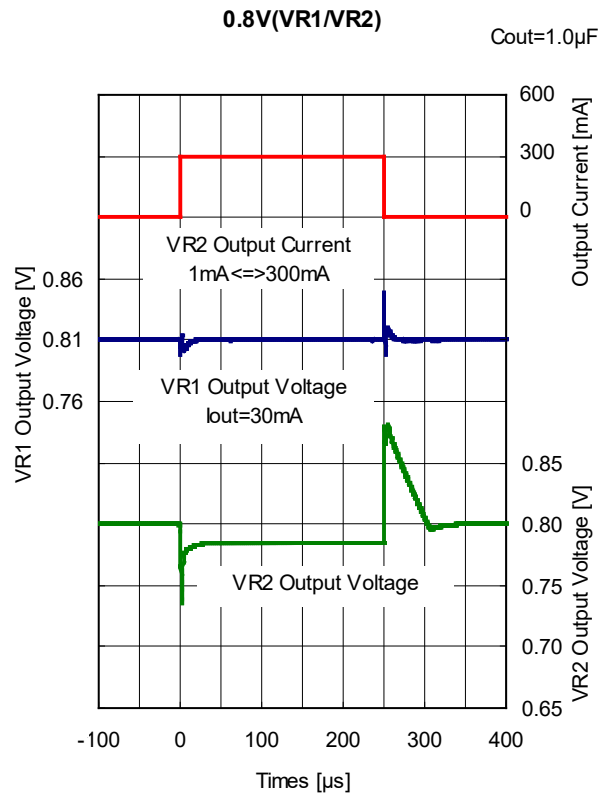
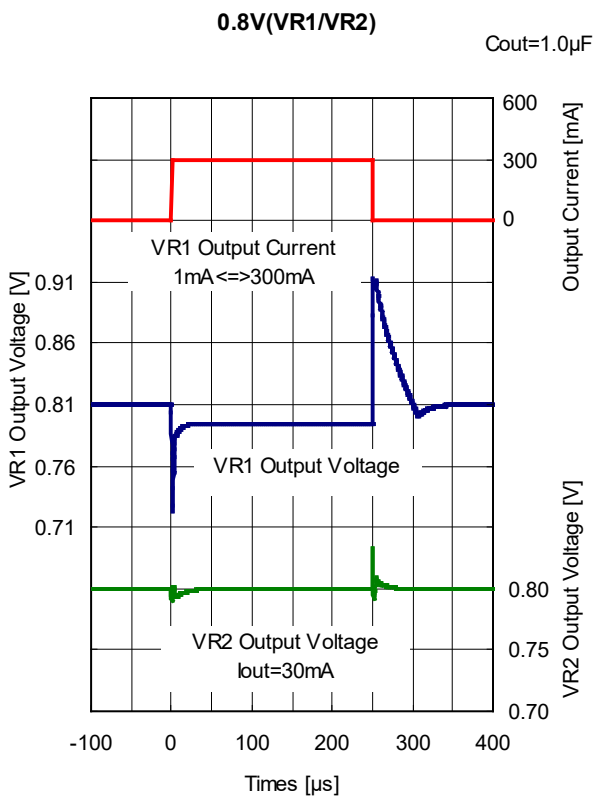

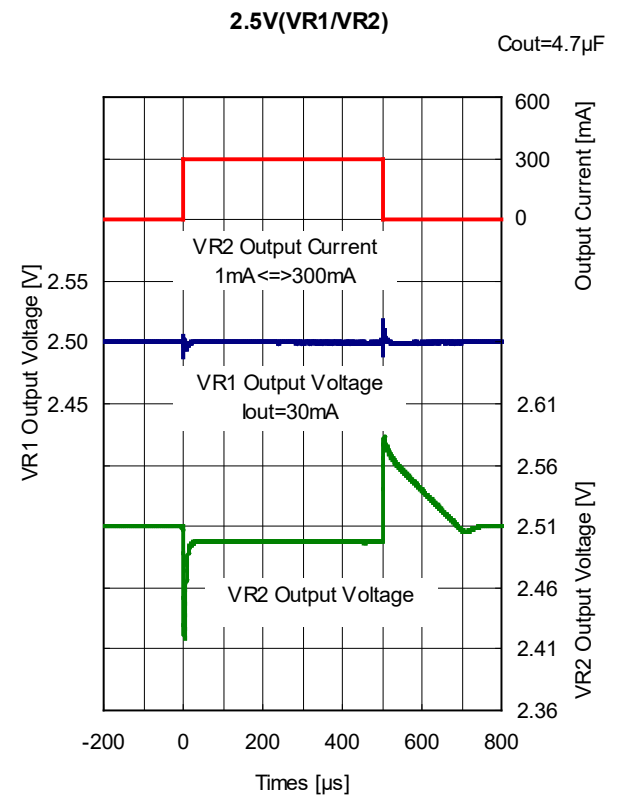
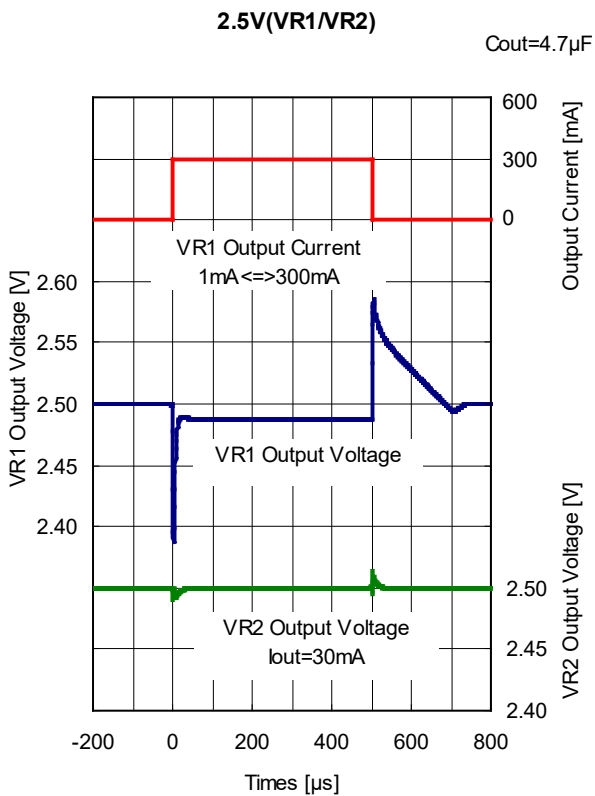
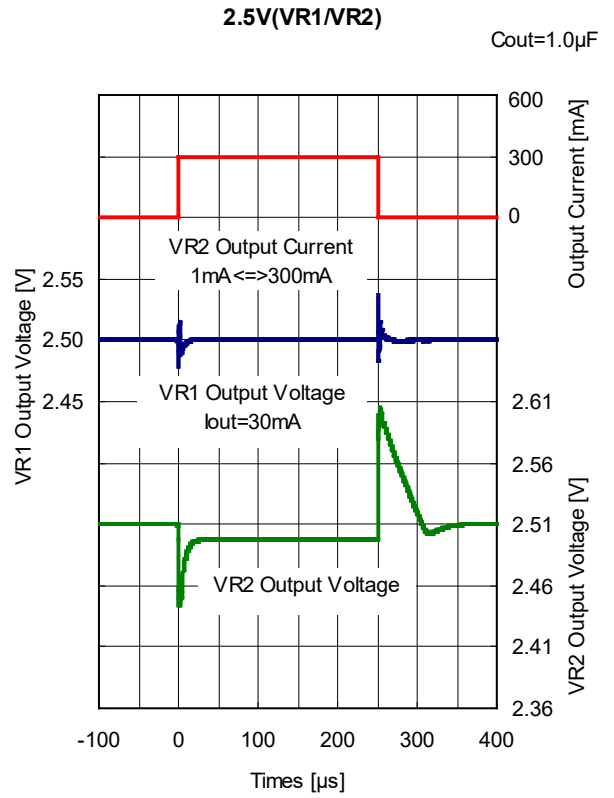
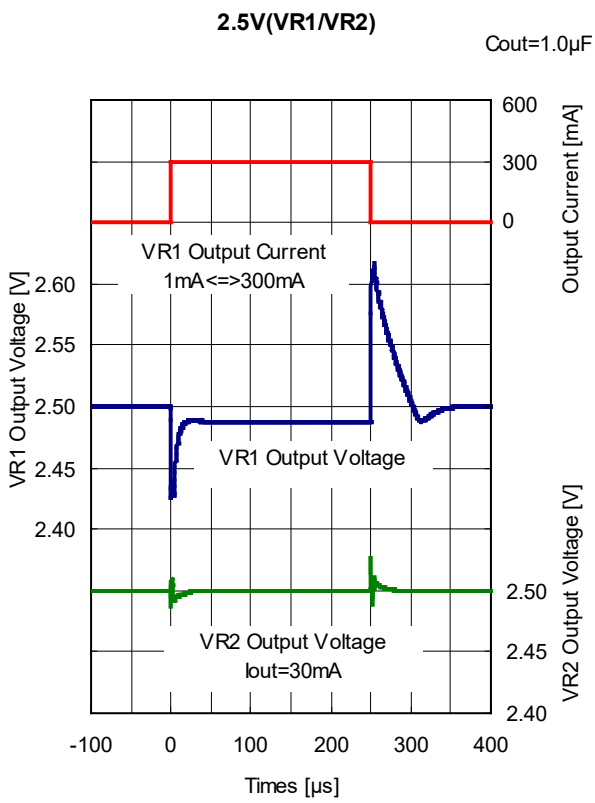



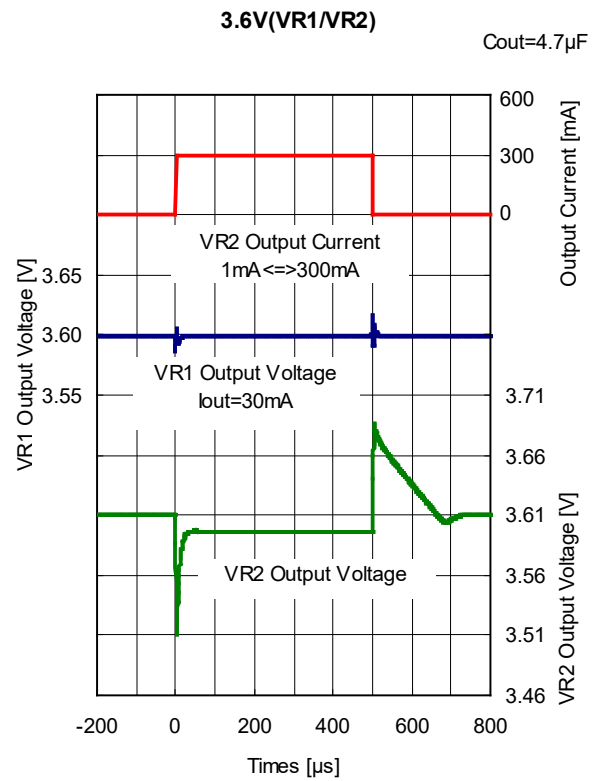
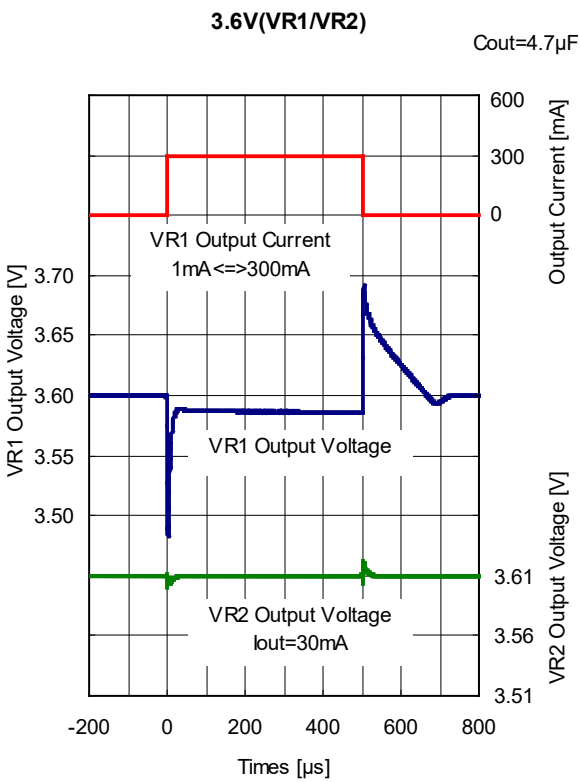
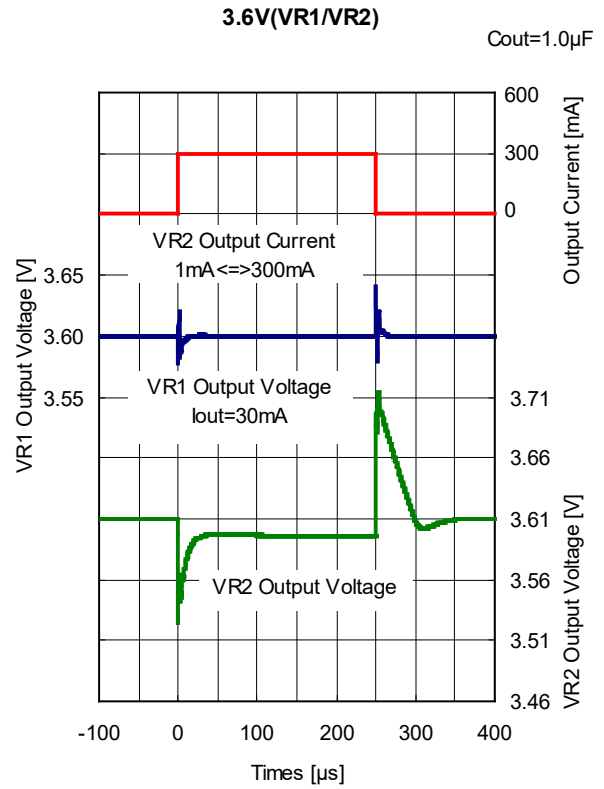
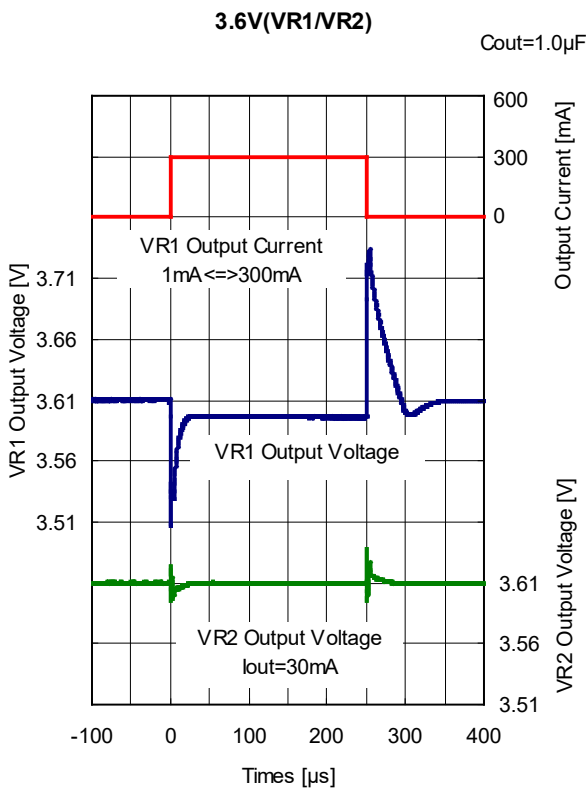

**12) Turn On Speed with CE pin ( $C_{IN} = 1.0 \mu F$ ,  $C_{OUT1} = C_{OUT2} = 1.0 \mu F$ ,  $T_a = 25^\circ C$ )**

**0.8V(VR1/VR2)**

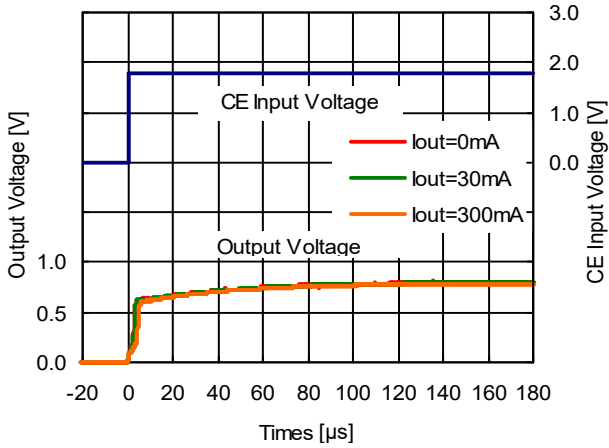

**2.5V(VR1/VR2)**

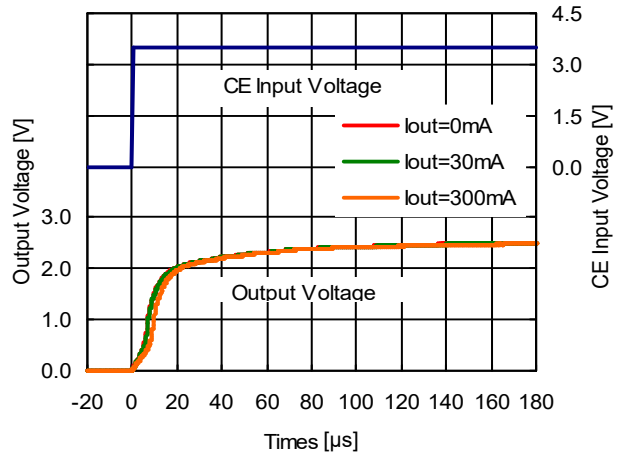

**3.6V(VR1/VR2)**

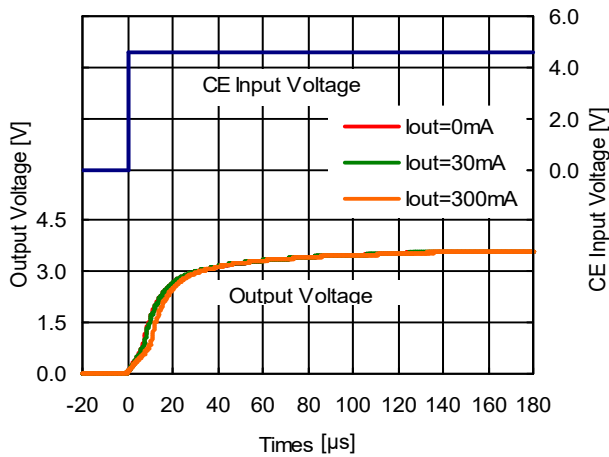

**13) Turn Off Speed with CE pin (RP154xxxxB) ( $C_{IN} = 1.0 \mu F$ ,  $C_{OUT1} = C_{OUT2} = 1.0 \mu F$ ,  $T_a = 25^\circ C$ )**

**0.8V(VR1/VR2)**

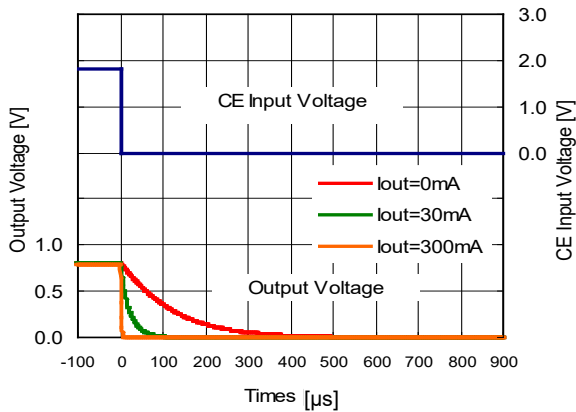

**2.5V(VR1/VR2)**

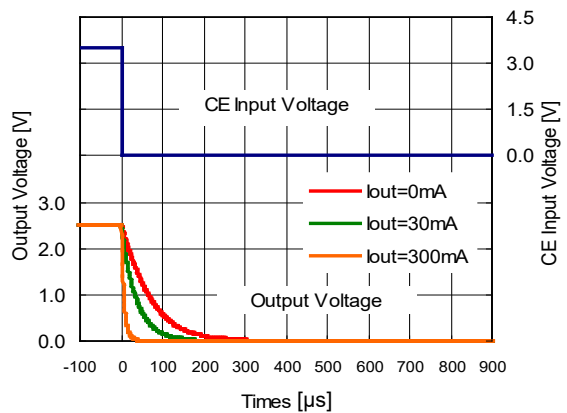

3.6V(VR1/VR2)

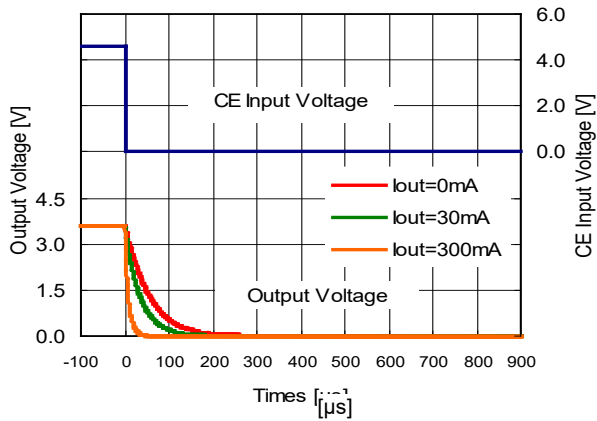

14) Turn Off Speed with CE pin (RP154xxxxA) (C<sub>IN</sub> = 1.0 μF, C<sub>OUT1</sub> = C<sub>OUT2</sub> = 1.0 μF, I<sub>OUT</sub> = 0 mA, Ta = 25°C)

0.8V(VR1/VR2)

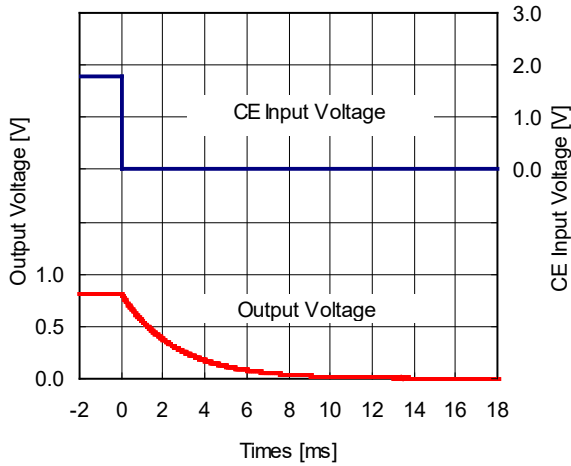

2.5V(VR1/VR2)

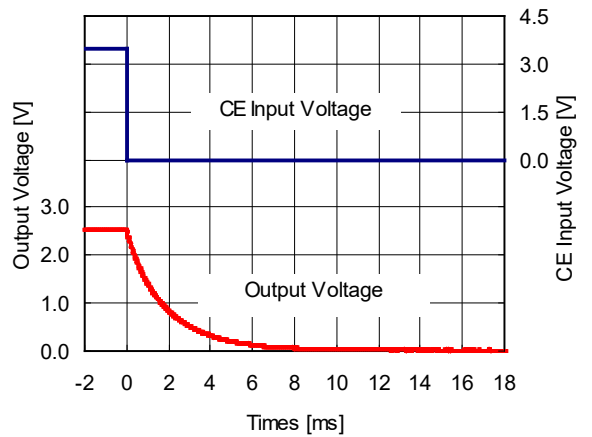

3.6V(VR1/VR2)

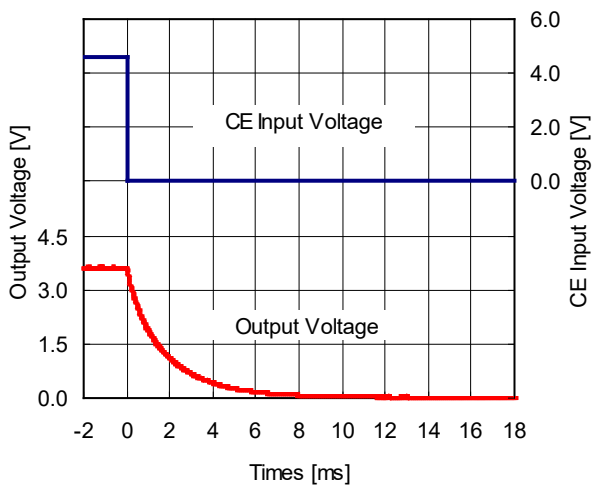

## ESR vs. Output Current

When using these ICs, consider the following points:

The relations between  $I_{OUT}$  (Output Current) and ESR of an output capacitor are shown below.

The conditions when the white noise level is under  $40\ \mu\text{V}$  (Avg.) are marked as the hatched area in the graph.

### Measurement conditions

Frequency Band: 10 Hz to 2 MHz

Temperature:  $-40^{\circ}\text{C}$  to  $85^{\circ}\text{C}$

$C_{IN}$ ,  $C_{OUT1}$ ,  $C_{OUT2}$ :  $1.0\ \mu\text{F}$

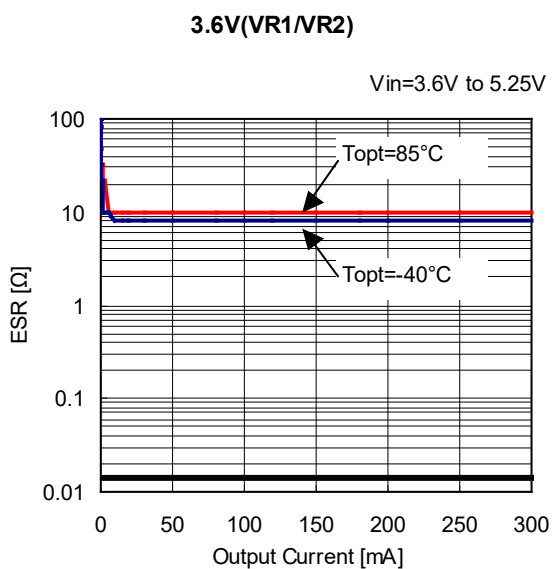
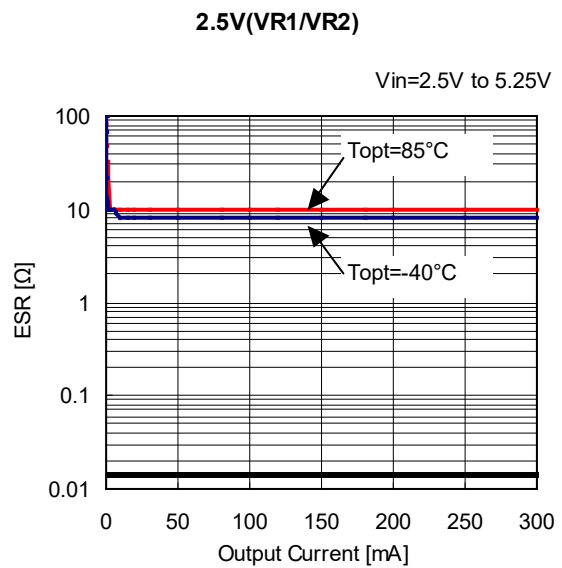
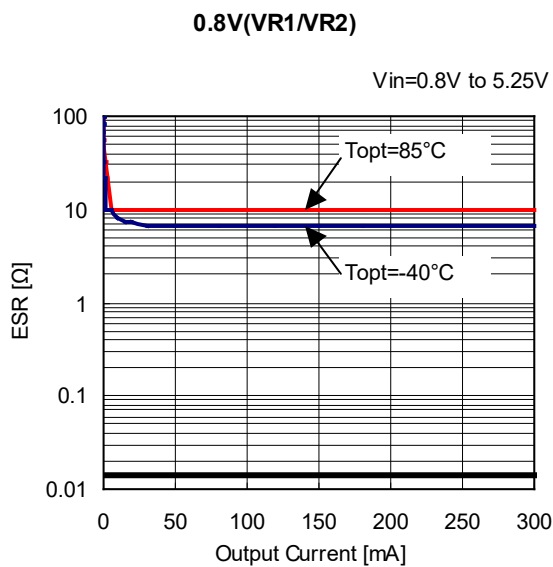

The power dissipation of the package is dependent on PCB material, layout, and environmental conditions. The following measurement conditions are based on JEDEC STD. 51-7.

**Measurement Conditions**

Item	Measurement Conditions
Environment	Mounting on Board (Wind Velocity = 0 m/s)
Board Material	Glass Cloth Epoxy Plastic (Four-Layer Board)
Board Dimensions	76.2 mm × 114.3 mm × 0.8 mm
Copper Ratio	Outer Layer (First Layer): Less than 95% of 50 mm Square Inner Layers (Second and Third Layers): Approx. 100% of 50 mm Square Outer Layer (Fourth Layer): Approx. 100% of 50 mm Square
Through-holes	φ 0.2 mm × 15 pcs

**Measurement Result**

(Ta = 25°C, Tjmax = 125°C)

Item	Measurement Result
Power Dissipation	1700 mW
Thermal Resistance (θja)	θja = 56°C/W
Thermal Characterization Parameter (ψjt)	ψjt = 18°C/W

θja: Junction-to-Ambient Thermal Resistance

ψjt: Junction-to-Top Thermal Characterization Parameter

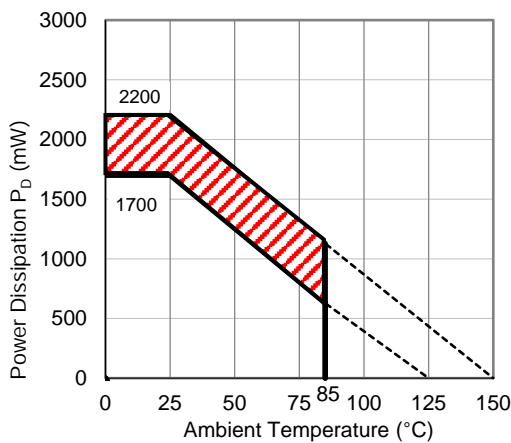

**Power Dissipation vs. Ambient Temperature**

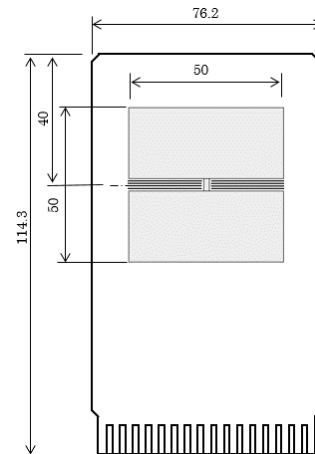

**Measurement Board Pattern**

The above graph shows the power dissipation of the package at Tjmax = 125°C and Tjmax = 150°C. Operating the device in the hatched range might have a negative influence on its lifetime. The total hours of use and the total years of use must be limited as follows:

Total Hours of Use	Total Years of Use (4 hours/day)
13,000 hours	9 years

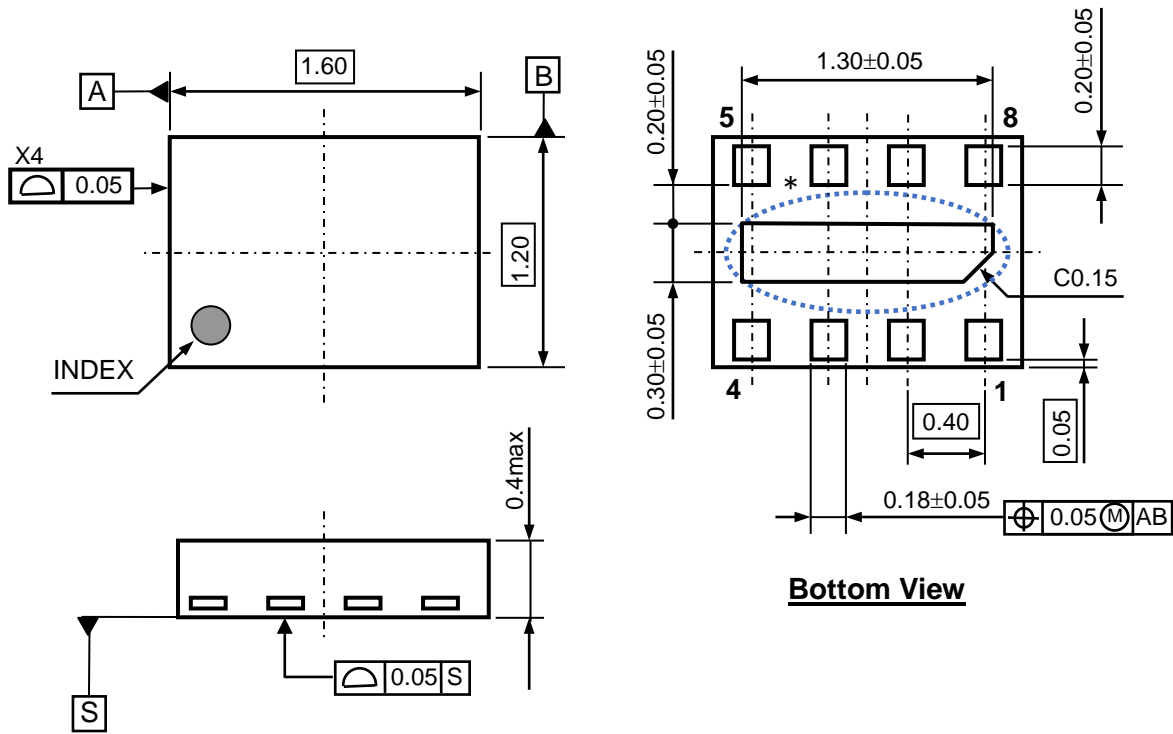

UNIT: mm

DFN1216-8 Package Dimensions

\* The tab on the bottom of the package shown by blue circle is a substrate potential (GND). It is recommended that this tab be connected to the ground plane on the board but it is possible to leave the tab floating.

The power dissipation of the package is dependent on PCB material, layout, and environmental conditions. The following measurement conditions are based on JEDEC STD. 51-7.

**Measurement Conditions**

Item	Measurement Conditions
Environment	Mounting on Board (Wind Velocity = 0 m/s)
Board Material	Glass Cloth Epoxy Plastic (Four-Layer Board)
Board Dimensions	76.2 mm × 114.3 mm × 0.8 mm
Copper Ratio	Outer Layer (First Layer): Less than 95% of 50 mm Square Inner Layers (Second and Third Layers): Approx. 100% of 50 mm Square Outer Layer (Fourth Layer): Approx. 100% of 50 mm Square
Through-holes	φ 0.3 mm × 7 pcs

**Measurement Result**

(Ta = 25°C, Tjmax = 125°C)

Item	Measurement Result
Power Dissipation	660 mW
Thermal Resistance (θja)	θja = 150°C/W
Thermal Characterization Parameter (ψjt)	ψjt = 51°C/W

θja: Junction-to-Ambient Thermal Resistance

ψjt: Junction-to-Top Thermal Characterization Parameter

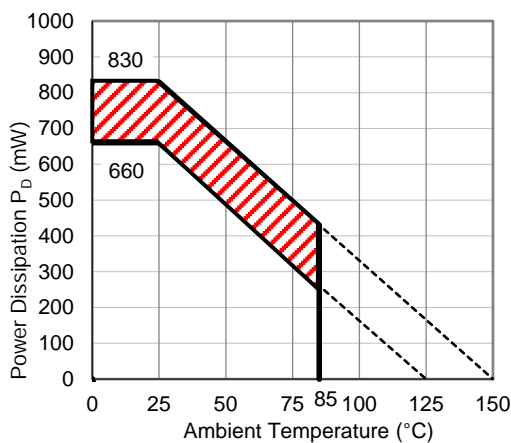

**Power Dissipation vs. Ambient Temperature**

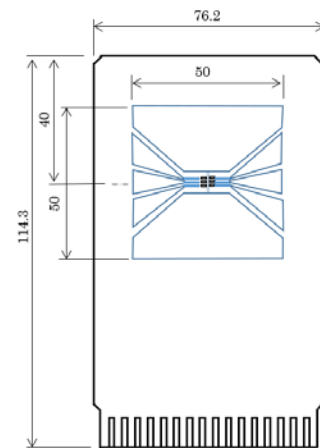

**Measurement Board Pattern**

The above graph shows the power dissipation of the package at Tjmax = 125°C and Tjmax = 150°C. Operating the device in the hatched range might have a negative influence on its lifetime. The total hours of use and the total years of use must be limited as follows:

Total Hours of Use	Total Years of Use (4 hours/day)
13,000 hours	9 years

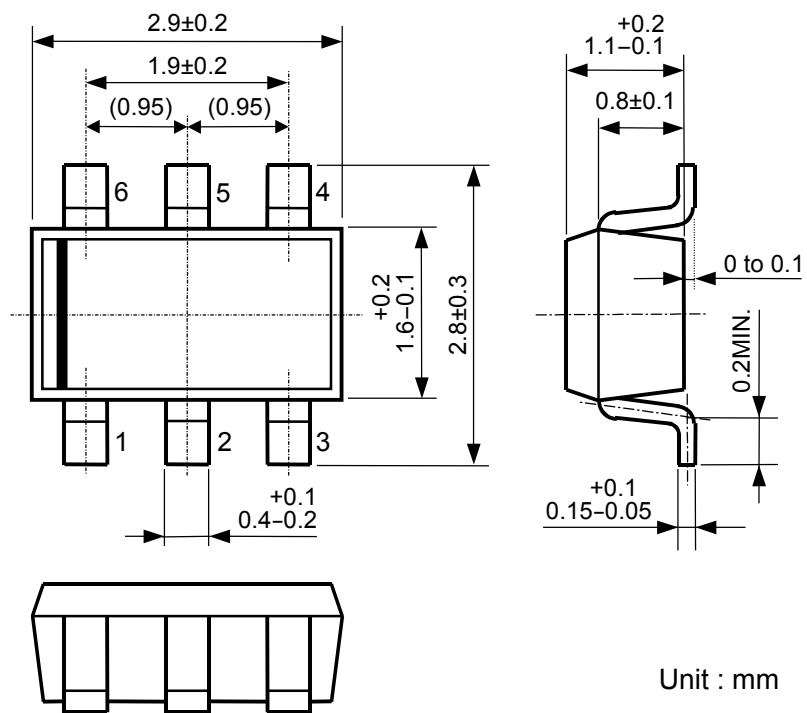

Unit : mm

SOT-23-6 Package Dimensions





1. The products and the product specifications described in this document are subject to change or discontinuation of production without notice for reasons such as improvement. Therefore, before deciding to use the products, please refer to Ricoh sales representatives for the latest information thereon.
2. The materials in this document may not be copied or otherwise reproduced in whole or in part without prior written consent of Ricoh.
3. Please be sure to take any necessary formalities under relevant laws or regulations before exporting or otherwise taking out of your country the products or the technical information described herein.
4. The technical information described in this document shows typical characteristics of and example application circuits for the products. The release of such information is not to be construed as a warranty of or a grant of license under Ricoh's or any third party's intellectual property rights or any other rights.
5. The products listed in this document are intended and designed for use as general electronic components in standard applications (office equipment, telecommunication equipment, measuring instruments, consumer electronic products, amusement equipment etc.). Those customers intending to use a product in an application requiring extreme quality and reliability, for example, in a highly specific application where the failure or misoperation of the product could result in human injury or death (aircraft, spacevehicle, nuclear reactor control system, traffic control system, automotive and transportation equipment, combustion equipment, safety devices, life support system etc.) should first contact us.
6. We are making our continuous effort to improve the quality and reliability of our products, but semiconductor products are likely to fail with certain probability. In order to prevent any injury to persons or damages to property resulting from such failure, customers should be careful enough to incorporate safety measures in their design, such as redundancy feature, fire containment feature and fail-safe feature. We do not assume any liability or responsibility for any loss or damage arising from misuse or inappropriate use of the products.
7. Anti-radiation design is not implemented in the products described in this document.
8. The X-ray exposure can influence functions and characteristics of the products. Confirm the product functions and characteristics in the evaluation stage.
9. WLCSP products should be used in light shielded environments. The light exposure can influence functions and characteristics of the products under operation or storage.
10. There can be variation in the marking when different AOI (Automated Optical Inspection) equipment is used. In the case of recognizing the marking characteristic with AOI, please contact Ricoh sales or our distributor before attempting to use AOI.
11. Please contact Ricoh sales representatives should you have any questions or comments concerning the products or the technical information.



**Ricoh is committed to reducing the environmental loading materials in electrical devices with a view to contributing to the protection of human health and the environment.**

Ricoh has been providing RoHS compliant products since April 1, 2006 and Halogen-free products since April 1, 2012.

**RICOH** RICOH ELECTRONIC DEVICES CO., LTD.

**Official website**

<https://www.n-redc.co.jp/en/>

**Contact us**

<https://www.n-redc.co.jp/en/buy/>

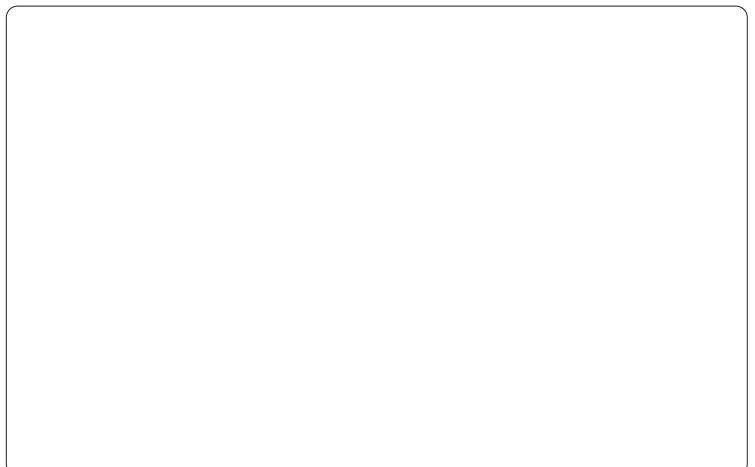

## X-ON Electronics

Largest Supplier of Electrical and Electronic Components

*Click to view similar products for [LDO Voltage Regulators](#) category:*

*Click to view products by [Nisshinbo](#) manufacturer:*

Other Similar products are found below :

[AP7363-SP-13](#) [L79M05TL-E](#) [PT7M8202B12TA5EX](#) [TCR3DF185,LM\(CT](#) [TCR3DF24,LM\(CT](#) [TCR3DF285,LM\(CT](#) [TCR3DF31,LM\(CT](#)  
[TCR3DF45,LM\(CT](#) [MP2013GQ-33-Z](#) [059985X](#) [NCP4687DH15T1G](#) [701326R](#) [TCR2EN28,LF\(S](#) [NCV8170AXV250T2G](#)  
[TCR3DF27,LM\(CT](#) [TCR3DF19,LM\(CT](#) [TCR3DF125,LM\(CT](#) [TCR2EN18,LF\(S](#) [AP2112R5A-3.3TRG1](#) [AP7315-25W5-7](#)  
[IFX30081LDVGRNXUMA1](#) [NCV47411PAAJR2G](#) [AP2113KTR-G1](#) [AP2111H-1.2TRG1](#) [ZLDO1117QK50TC](#) [AZ1117IH-1.8TRG1](#)  
[AZ1117ID-ADJTRG1](#) [TCR3DG12,LF](#) [MIC5514-3.3YMT-T5](#) [MIC5512-1.2YMT-T5](#) [MIC5317-2.8YM5-T5](#) [SCD7912BTG](#)  
[NCP154MX180270TAG](#) [SCD33269T-5.0G](#) [NCV8170BMX330TCG](#) [NCV8170AMX120TCG](#) [NCP706ABMX300TAG](#)  
[NCP153MX330180TCG](#) [NCP114BMX075TCG](#) [MC33269T-3.5G](#) [CAT6243-ADJCMT5T](#) [TCR3DG33,LF](#) [AP2127N-1.0TRG1](#)  
[TCR4DG35,LF](#) [LT1117CST-3.3](#) [TAR5S15U\(TE85L,F\)](#) [TAR5S18U\(TE85L,F\)](#) [TCR3UG19A,LF](#) [TCR4DG105,LF](#) [NCV8170AMX360TCG](#)