

## Features

- GaN on Si HEMT Depletion Mode Transistor
- Suitable for Linear and Saturated Applications
- Tunable from DC - 3.5 GHz
- 48 V Operation
- 13.5 dB Gain at 3.5 GHz
- 55 % Drain Efficiency at 3.5 GHz
- 100 % RF Tested
- Standard package with bolt down flange
- RoHS\* Compliant and 260°C reflow compatible



## Description

The NPT2020 GaN HEMT is a wideband transistor optimized for DC - 3.5 GHz operation. This device supports CW, pulsed, and linear operation with output power levels to 50 W (47 dBm) in an industry standard surface mount package.

The NPT2020 is ideally suited for defense communications, land mobile radio, avionics, wireless infrastructure, ISM applications and VHF/UHF/L/S-band radar.

Built using the SIGANTIC® process - a proprietary GaN-on-Silicon technology.

## Functional Schematic

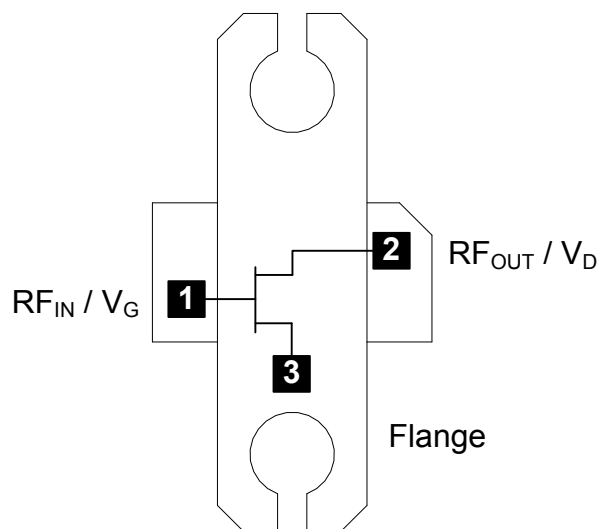

## Ordering Information

Part Number	Package
NPT2020	Bulk Quantity
NPT2020-SMBPPR	Custom Sample Board <sup>1</sup>
NPT2020-SMB2	1250-1850 MHz Sample Board

1. When ordering, specify application requirements (frequency, linearity, etc.)

## Pin Configuration

Pin No.	Pin Name	Function
1	RF <sub>IN</sub> / V <sub>G</sub>	RF Input / Gate
2	RF <sub>OUT</sub> / V <sub>D</sub>	RF Output / Drain
3	Flange <sup>2</sup>	Ground / Source

2. The Flange must be connected to RF and DC ground. This path must also provide a low thermal resistance heat path.

\* Restrictions on Hazardous Substances, European Union Directive 2011/65/EU.

## GaN Wideband Transistor 48 V, 50 W DC - 3.5 GHz

Rev. V1

### RF Electrical Specifications: $T_A = 25\text{ }^\circ\text{C}$ , $V_{DS} = 48\text{ V}$ , $I_{DQ} = 350\text{ mA}$

Parameter	Test Conditions	Symbol	Min.	Typ.	Max.	Units
Small Signal Gain	CW, 3.5 GHz	$G_{SS}$	-	14.5	-	dB
Saturated Output Power	CW, 3.5 GHz	$P_{SAT}$	-	48	-	dBm
Drain Efficiency at Saturation	CW, 3.5 GHz	$\eta_{SAT}$	-	60	-	%
Power Gain	3.5 GHz, $P_{OUT} = 50\text{ W}$	$G_P$	12	13.5	-	dB
Drain Efficiency	3.5 GHz, $P_{OUT} = 50\text{ W}$	$\eta$	50	55	-	%
Ruggedness: Output Mismatch	All phase angles	$\Psi$	VSWR = 10:1, No Device Damage			

### DC Electrical Characteristics: $T_A = 25\text{ }^\circ\text{C}$

Parameter	Test Conditions	Symbol	Min.	Typ.	Max.	Units
Drain-Source Leakage Current	$V_{GS} = -8\text{ V}$ , $V_{DS} = 160\text{ V}$	$I_{DLK}$	-	-	14	mA
Gate-Source Leakage Current	$V_{GS} = -8\text{ V}$ , $V_{DS} = 0\text{ V}$	$I_{GLK}$	-	-	7	mA
Gate Threshold Voltage	$V_{DS} = 48\text{ V}$ , $I_D = 14\text{ mA}$	$V_T$	-2.5	-1.5	-0.5	V
Gate Quiescent Voltage	$V_{DS} = 48\text{ V}$ , $I_D = 350\text{ mA}$	$V_{GSQ}$	-2.1	-1.2	-0.3	V
On Resistance	$V_{DS} = 2\text{ V}$ , $I_D = 105\text{ mA}$	$R_{ON}$	-	0.34	-	$\Omega$
Saturated Drain Current	$V_{DS} = 7\text{ V}$ pulsed, pulse width 300 $\mu\text{s}$	$I_{D,MAX}$	-	8.2	-	A

## Absolute Maximum Ratings<sup>3,4,5</sup>

Parameter	Absolute Maximum
Drain Source Voltage, $V_{DS}$	160 V
Gate Source Voltage, $V_{GS}$	-10 to 3 V
Gate Current, $I_G$	28 mA
Junction Temperature, $T_J$	+200°C
Operating Temperature	-40°C to +55°C
Storage Temperature	-65°C to +150°C

3. Exceeding any one or combination of these limits may cause permanent damage to this device.
4. MACOM does not recommend sustained operation near these survivability limits.
5. Operating at nominal conditions with  $T_J \leq 200^\circ\text{C}$  will ensure  $\text{MTTF} > 1 \times 10^6$  hours.

## Thermal Characteristics<sup>6</sup>

Parameter	Test Conditions	Symbol	Typical	Units
Thermal Resistance	$V_{DS} = 48 \text{ V}, T_J = 200^\circ\text{C}$	$R_{\theta JC}$	2.1	°C/W

6. Junction temperature ( $T_J$ ) measured using IR Microscopy. Case temperature measured using thermocouple embedded in heat-sink.

## Handling Procedures

Please observe the following precautions to avoid damage:

## Static Sensitivity

Gallium Nitride Circuits are sensitive to electrostatic discharge (ESD) and can be damaged by static electricity. Proper ESD control techniques should be used when handling these HBM Class 1A devices.

**Load-Pull Performance:  $V_{DS} = 48\text{ V}$ ,  $I_{DQ} = 350\text{ mA}$ ,  $T_C = 25\text{ }^\circ\text{C}$**

**Reference Plane at Device Leads, CW Drain Efficiency and Output Power Tradeoff Impedance**

Frequency (MHz)	$Z_S$ ( $\Omega$ )	$Z_L$ ( $\Omega$ )	$P_{SAT}$ (W)	$G_{SS}$ (dB)	Drain Efficiency at $P_{SAT}$ (%)
2700	$1.6 - j7.2$	$2.9 + j2.3$	65	16.2	58
3100	$1.5 - j8.6$	$2.9 + j0.6$	64	16.1	55
3500	$1.9 - j10.7$	$2.9 - j0.7$	62	15.7	53

**Impedance Reference**

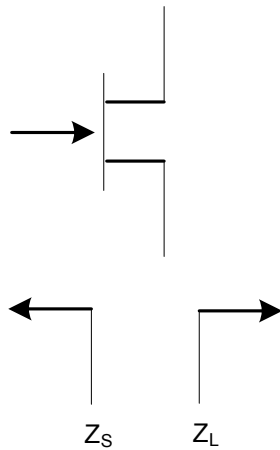

**$Z_S$  and  $Z_L$  vs. Frequency**

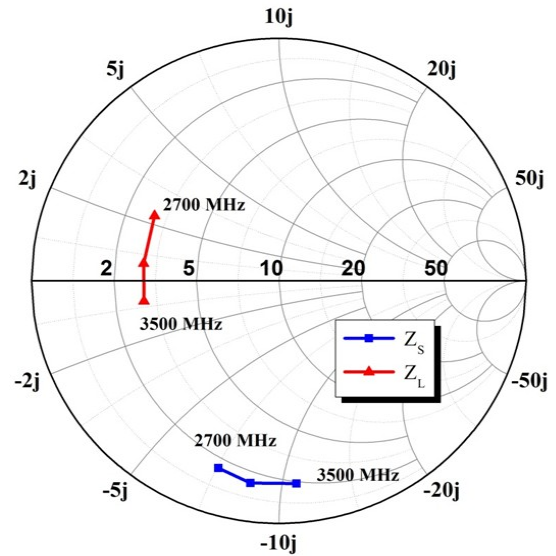

**Gain vs. Output Power**

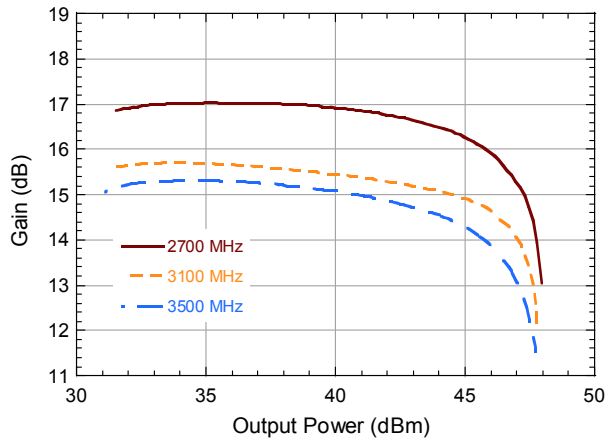

**Drain Efficiency vs. Output Power**

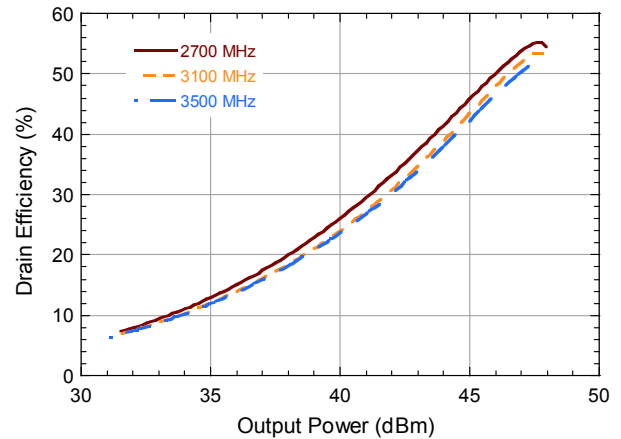

## Evaluation Board and Recommended Tuning Solution

### 3.5 GHz Narrowband Circuit

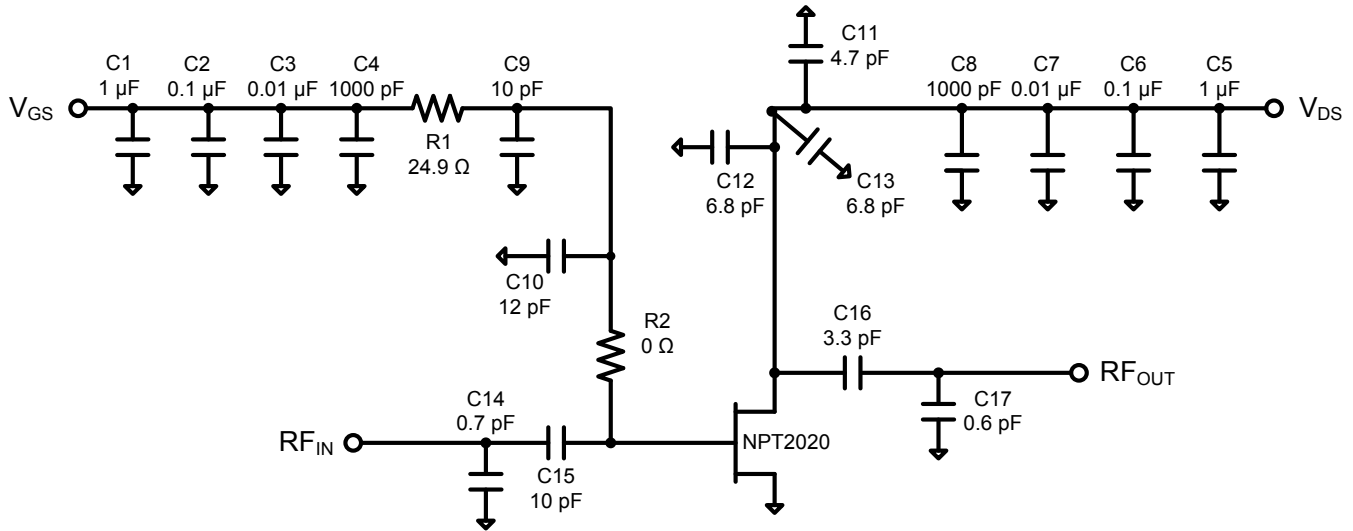

## Description

Parts measured on evaluation board (20-mil thick RO4350). Matching is provided using a combination of lumped elements and transmission lines as shown in the simplified schematic above. Recommended tuning solution component placement, transmission lines, and details are shown on the next page.

## Bias Sequencing

### Turning the device ON

1. Set  $V_{GS}$  to the pinch-off ( $V_P$ ), typically -5 V.
2. Turn on  $V_{DS}$  to nominal voltage (48 V).
3. Increase  $V_{GS}$  until the  $I_{DS}$  current is reached.
4. Apply RF power to desired level.

### Turning the device OFF

1. Turn the RF power off.
2. Decrease  $V_{GS}$  down to  $V_P$ .
3. Decrease  $V_{DS}$  down to 0 V.
4. Turn off  $V_{GS}$ .

**Evaluation Board and Recommended Tuning Solution**  
**3.5 GHz Narrowband Circuit**

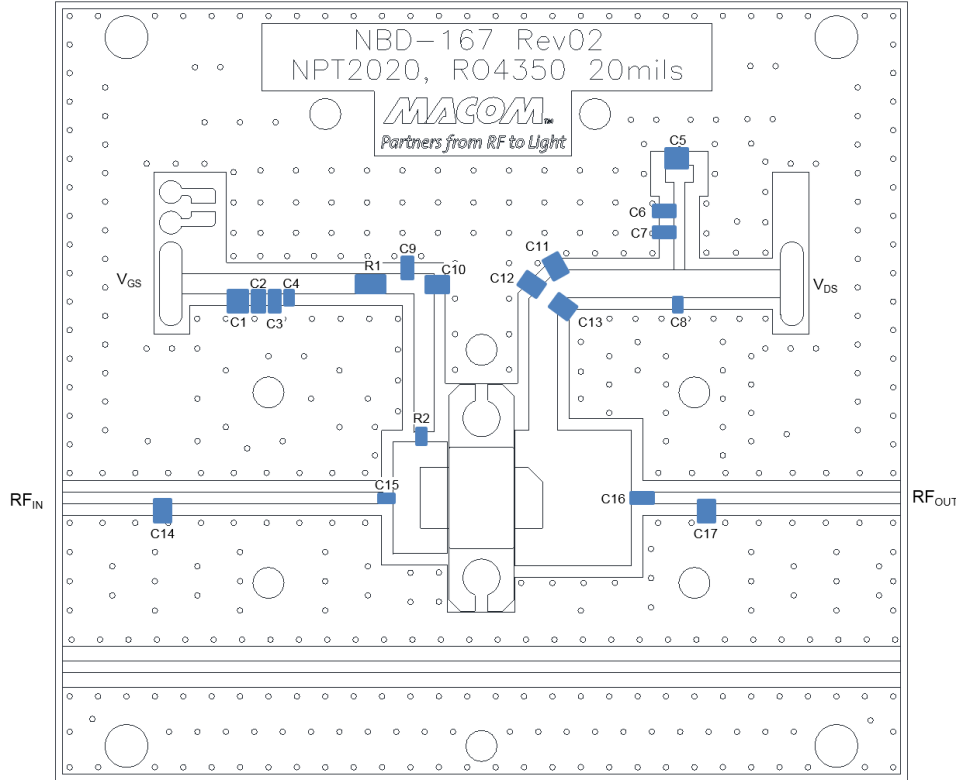

**Parts list**

Reference	Value	Tolerance	Manufacturer	Part Number
C1, C5	1 $\mu$ F	10%	AVX	1210C105KAT2A
C2, C6	0.1 $\mu$ F	10%	Kemet	C1206C104K1RACTU
C3, C7	0.01 $\mu$ F	10%	AVX	12061C103KAT2A
C4, C8	1000 pF	10%	Kemet	C0805C102K1RACTU
C9	10 pF	5%	ATC	ATC800B100JT500X
C10	12 pF	5%	ATC	ATC800B120JT500X
C11	4.7 pF	+/- 0.1 pF	ATC	ATC800B4R7BT500X
C12, C13	6.8 pF	+/- 0.1 pF	ATC	ATC800B6R8BT500X
C14	0.7 pF	+/- 0.1 pF	ATC	ATC800B0R7BT500X
C15	10 pF	5%	ATC	ATC800A100JT250X
C16	3.3 pF	+/- 0.1 pF	ATC	ATC800B3R3BT500X
C17	0.6 pF	+/- 0.1 pF	ATC	ATC800B0R6BT500X
R1	24.9 $\Omega$	1%	Panasonic	ERJ-6GEY24R9V
R2	0 $\Omega$	1%	Panasonic	ERJ-6ENF00R0V
PCB	Rogers RO4350, $\epsilon_r = 3.5$ , 20 mil			

**Typical Performance as Measured in the 3.5 GHz Evaluation Board:**  
**CW,  $V_{DS} = 48\text{ V}$ ,  $I_{DQ} = 350\text{ mA}$  (unless noted)**

**Gain vs. Output Power over Temperature**

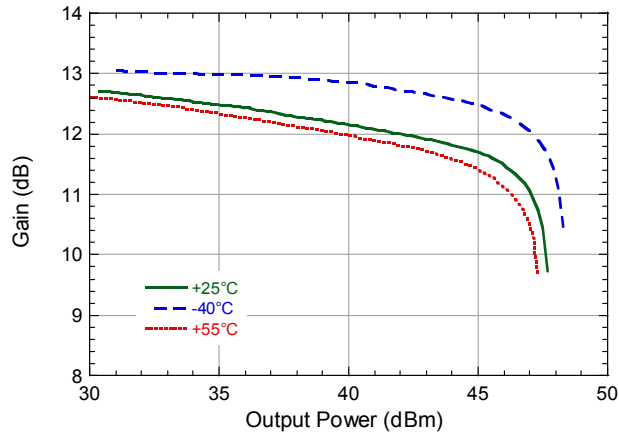

**Drain Efficiency vs. Output Power over Temperature**

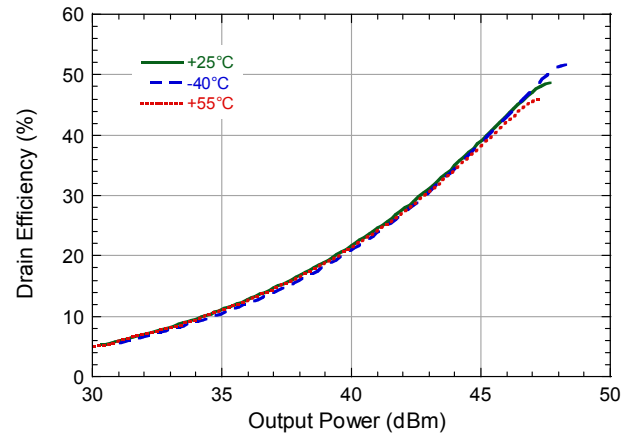

**Quiescent  $V_{GS}$  vs. Temperature**

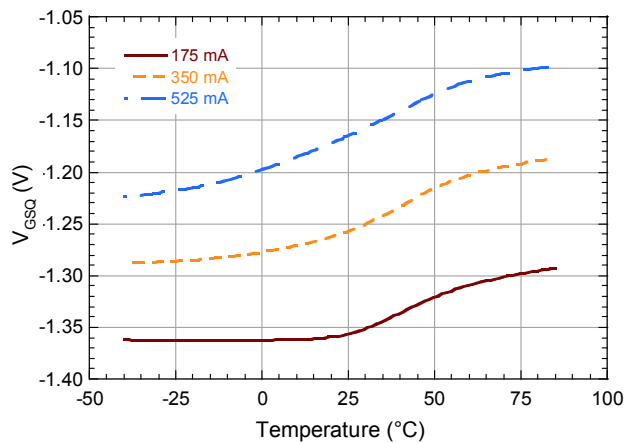

**Typical 2-Tone Performance as measured in the 3.5 GHz evaluation board:  
1 MHz Tone Spacing,  $V_{DS} = 48\text{ V}$ ,  $I_{DQ} = 350\text{ mA}$ ,  $T_C = 25\text{ }^\circ\text{C}$  (unless noted)**

**2-Tone IMD3 vs. Output Power vs. Quiescent Current**

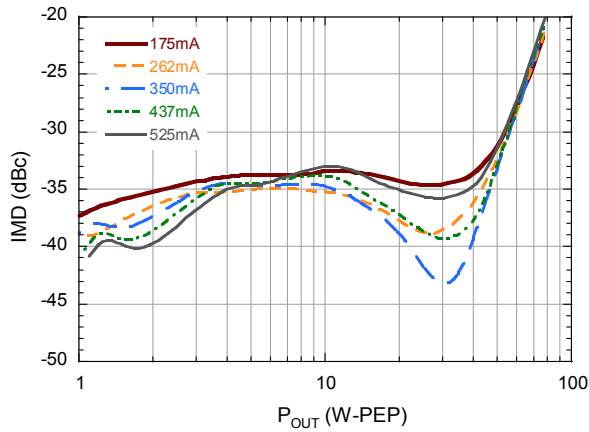

**2-Tone Gain vs. Output Power vs. Quiescent Current**

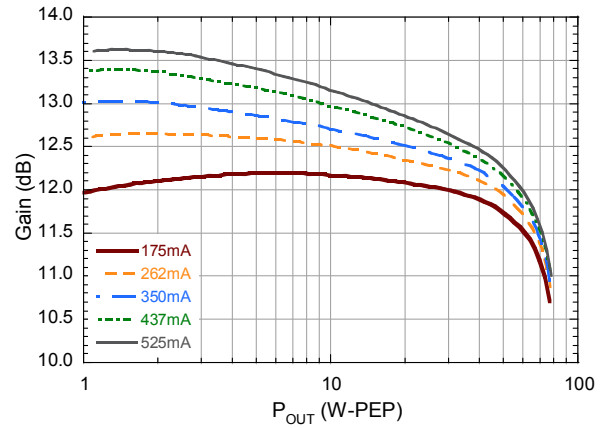

**2-Tone IMD vs. Output Power**

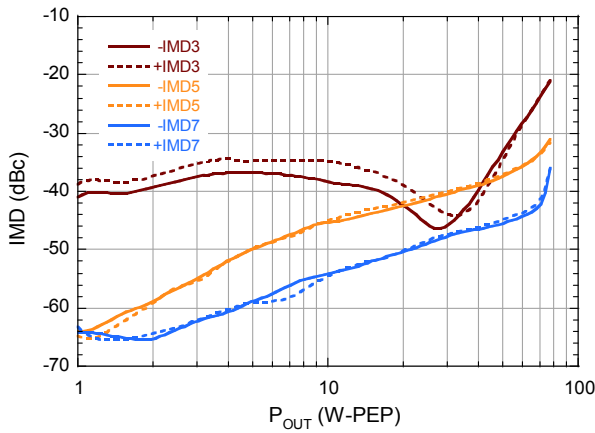



## Evaluation Board and Recommended Tuning Solution

### 1250-1850 MHz Broadband Circuit

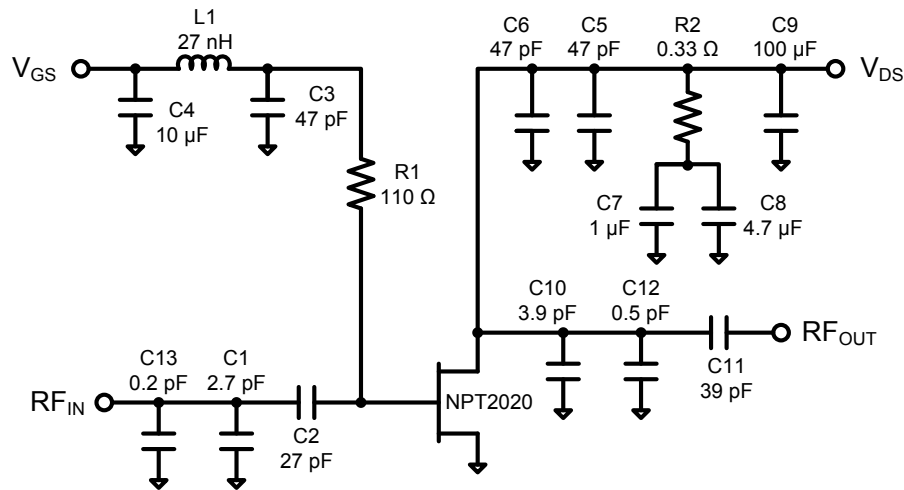

## Description

Parts measured on evaluation board (25-mil thick 6010LM). Matching is provided using a combination of lumped elements and transmission lines as shown in the simplified schematic above. Recommended tuning solution component placement, transmission lines, and details are shown on the next page.

## Bias Sequencing

### Turning the device ON

1. Set  $V_{GS}$  to the pinch-off ( $V_P$ ), typically -5 V.
2. Turn on  $V_{DS}$  to nominal voltage (48 V).
3. Increase  $V_{GS}$  until the  $I_{DS}$  current is reached.
4. Apply RF power to desired level.

### Turning the device OFF

1. Turn the RF power off.
2. Decrease  $V_{GS}$  down to  $V_P$ .
3. Decrease  $V_{DS}$  down to 0 V.
4. Turn off  $V_{GS}$ .

**Evaluation Board and Recommended Tuning Solution**  
**1250-1850 MHz Broadband Circuit**

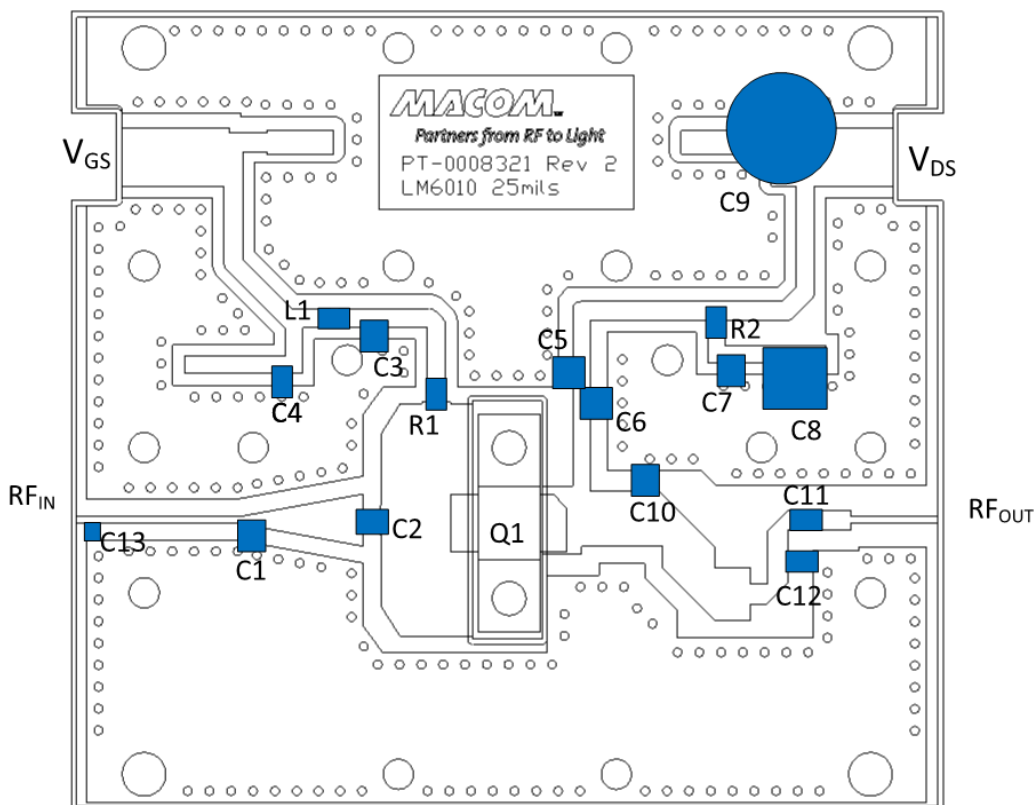

**Parts list**

Reference	Value	Tolerance	Vendor	Part Number
C1	2.7 pF	+/- 0.1pF	ATC	ATC800B2R7BT500X
C2	27 pF	5%	ATC	ATC800B270JT500X
C3, C5, C6	47pF	5%	ATC	ATC800B470JT500X
C4	10uF-16V	5%	Digikey	C2012X5R1C106M085AC
C7	1.0uF-100V	5%	Digikey	C12101C105KAT2A
C8	4.7uF	5%	Digikey	C5750X7R2A475K230KA
C9	100uF-63V	5%	Panasonic	ECE-V1JA101P
C10	3.9pF	+/- 0.1pF	ATC	ATC800B3R9BT500X
C11	39pF	5%	ATC	ATC800B390JT500X
C12	0.5pF	+/- 0.1pF	ATC	ATC800B0R5BT500X
C13	0.2pF	+/- 0.1pF	ATC	ATC800A0R2BT250X
L1	27nH	5%	Coilcraft	0908SQ-27N
R1	110 Ohms	5%	Digikey	CR1206-JW-1100ELF
R2	0.33 Ohms	5%	Digikey	ERJ-6RQFR33V
PCB	Rogers 6010LM, $\epsilon_r = 10.2$ , 25 mil			

**Typical Performance as Measured in the 1250-1850 MHz Evaluation Board:  
CW, VDS = 48 V, IDQ = 350 mA, TA = 25 °C (unless noted)**

**Gain & Drain Efficiency vs. Frequency (Max Power)**

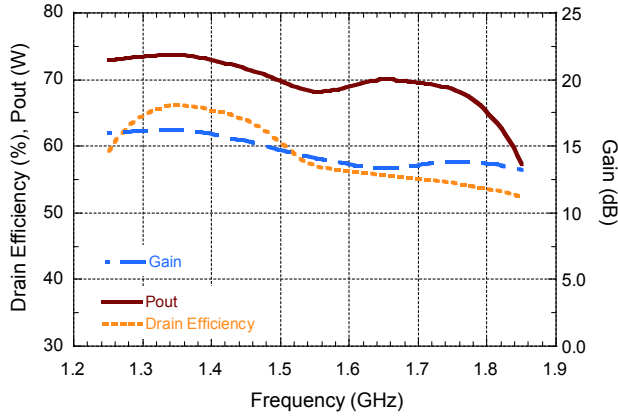

**Gain & Drain Efficiency vs. Frequency (P<sub>OUT</sub> = 50 W)**

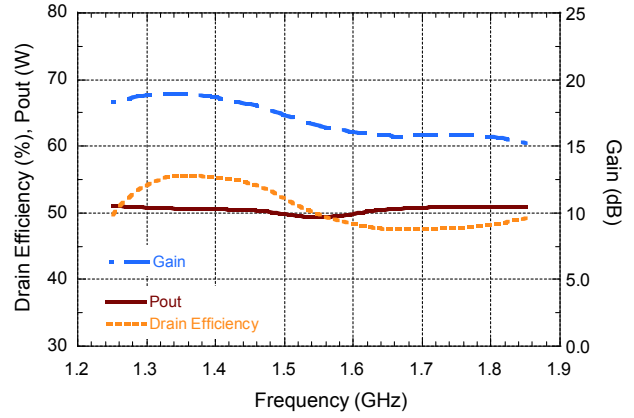

**Gain & Drain Efficiency vs. P<sub>OUT</sub>**

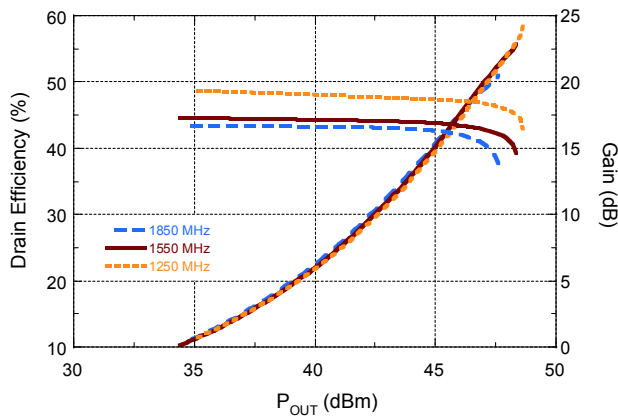

## AC360B-2 Metal-Ceramic Package<sup>†</sup>

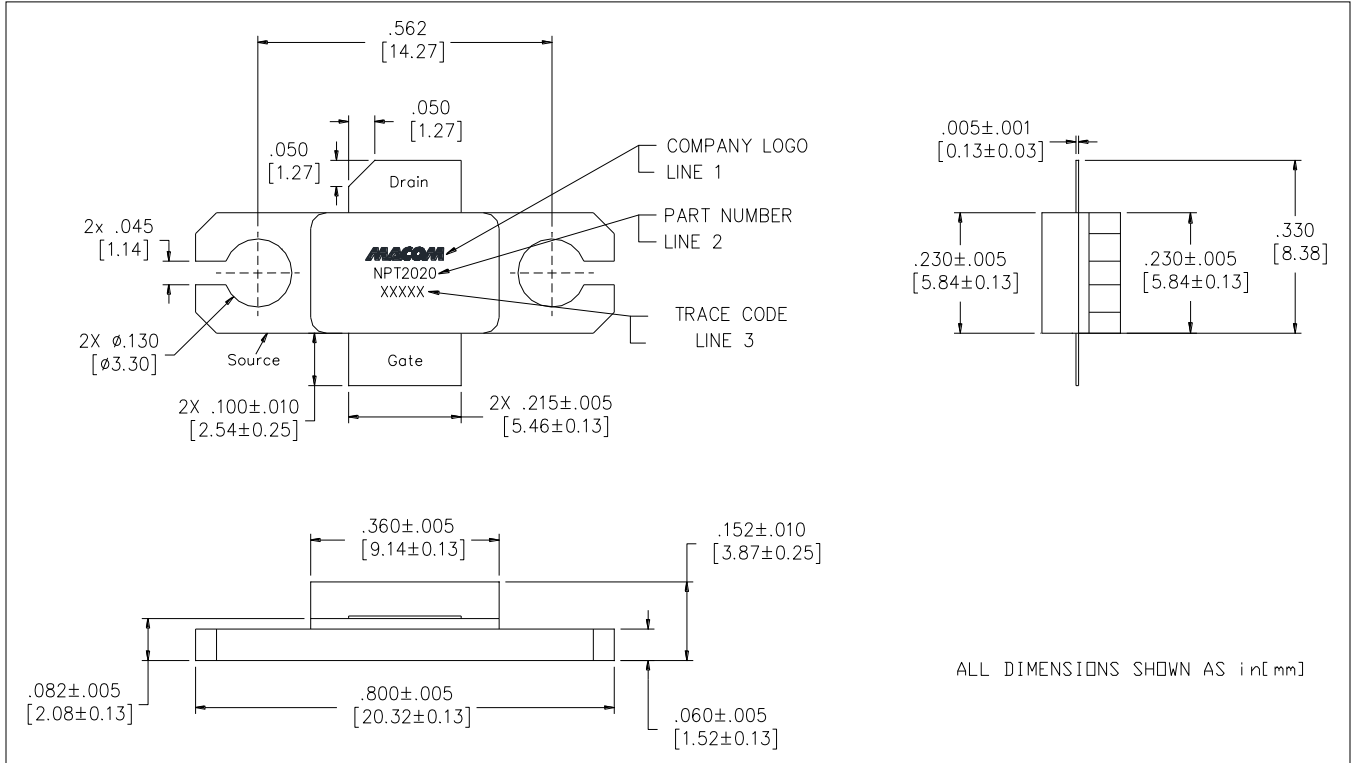

<sup>†</sup> Meets JEDEC moisture sensitivity level 1 requirements.  
Plating is Ni / Au.

M/A-COM Technology Solutions Inc. All rights reserved.

Information in this document is provided in connection with M/A-COM Technology Solutions Inc ("MACOM") products. These materials are provided by MACOM as a service to its customers and may be used for informational purposes only. Except as provided in MACOM's Terms and Conditions of Sale for such products or in any separate agreement related to this document, MACOM assumes no liability whatsoever. MACOM assumes no responsibility for errors or omissions in these materials. MACOM may make changes to specifications and product descriptions at any time, without notice. MACOM makes no commitment to update the information and shall have no responsibility whatsoever for conflicts or incompatibilities arising from future changes to its specifications and product descriptions. No license, express or implied, by estoppel or otherwise, to any intellectual property rights is granted by this document.

THESE MATERIALS ARE PROVIDED "AS IS" WITHOUT WARRANTY OF ANY KIND, EITHER EXPRESS OR IMPLIED, RELATING TO SALE AND/OR USE OF MACOM PRODUCTS INCLUDING LIABILITY OR WARRANTIES RELATING TO FITNESS FOR A PARTICULAR PURPOSE, CONSEQUENTIAL OR INCIDENTAL DAMAGES, MERCHANTABILITY, OR INFRINGEMENT OF ANY PATENT, COPYRIGHT OR OTHER INTELLECTUAL PROPERTY RIGHT. MACOM FURTHER DOES NOT WARRANT THE ACCURACY OR COMPLETENESS OF THE INFORMATION, TEXT, GRAPHICS OR OTHER ITEMS CONTAINED WITHIN THESE MATERIALS. MACOM SHALL NOT BE LIABLE FOR ANY SPECIAL, INDIRECT, INCIDENTAL, OR CONSEQUENTIAL DAMAGES, INCLUDING WITHOUT LIMITATION, LOST REVENUES OR LOST PROFITS, WHICH MAY RESULT FROM THE USE OF THESE MATERIALS.

MACOM products are not intended for use in medical, lifesaving or life sustaining applications. MACOM customers using or selling MACOM products for use in such applications do so at their own risk and agree to fully indemnify MACOM for any damages resulting from such improper use or sale.

## X-ON Electronics

Largest Supplier of Electrical and Electronic Components

*Click to view similar products for [MOSFET](#) category:*

*Click to view products by [Nitronex](#) manufacturer:*

Other Similar products are found below :

[614233C](#) [648584F](#) [MCH3443-TL-E](#) [MCH6422-TL-E](#) [FDPF9N50NZ](#) [FW216A-TL-2W](#) [FW231A-TL-E](#) [APT5010JVR](#) [NTNS3A92PZT5G](#)  
[IRF100S201](#) [JANTX2N5237](#) [2SK2464-TL-E](#) [2SK3818-DL-E](#) [FCA20N60\\_F109](#) [FDZ595PZ](#) [STD6600NT4G](#) [FSS804-TL-E](#) [2SJ277-DL-E](#)  
[2SK1691-DL-E](#) [2SK2545\(Q,T\)](#) [D2294UK](#) [405094E](#) [423220D](#) [MCH6646-TL-E](#) [TPCC8103,L1Q\(CM](#) [367-8430-0972-503](#) [VN1206L](#)  
[424134F](#) [026935X](#) [051075F](#) [SBVS138LT1G](#) [614234A](#) [715780A](#) [NTNS3166NZT5G](#) [751625C](#) [873612G](#) [IRF7380TRHR](#)  
[IPS70R2K0CEAKMA1](#) [RJK60S3DPP-E0#T2](#) [RJK60S5DPK-M0#T0](#) [APT5010JVFR](#) [APT12031JFLL](#) [APT12040JVR](#) [DMN3404LQ-7](#)  
[NTE6400](#) [JANTX2N6796U](#) [JANTX2N6784U](#) [JANTXV2N5416U4](#) [SQM110N05-06L-GE3](#) [SIHF35N60E-GE3](#)