

1.5/1.9GHz LOW NOISE AMPLIFIER

GaAs MMIC

■GENERAL DESCRIPTION

NJG1103F1 is a Low Noise Amplifier GaAs MMIC designed for 1.5GHz and 1.9GHz band digital cellular phone and Japanese PHS handsets.

This amplifier provides low noise figure, high gain and high IP3 operated by single low positive power supply.

This amplifier can be tuned to wide frequency point. (Best for 1.5GHz or 1.9GHz)

Small package of MTP6-1 is adopted.

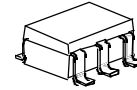
■PACKAGE OUTLINE

NJG1103F1

■FEATURES

- | | |
|--------------------------|--|
| ●Low voltage operation | +2.7V typ. |
| ●Low current consumption | 3mA typ. |
| ●High small signal gain | 16dB typ. @f=1.489GHz |
| | 14dB typ. @f=1.9GHz |
| ●Low Noise Figure | 1.2dB typ. @f=1.489GHz |
| | 1.4dB typ. @f=1.9GHz |
| ●High Input IP3 | -4dBm typ. @f=1.489+1.4891GHz |
| | -3dBm typ. @f=1.9+1.9001GHz |
| ●High Output IP3 | +12dBm typ. @f=1.489+1.4891GHz |
| | +11dBm typ. @f=1.9+1.9001GHz |
| ●Package | MTP6-1 (Mount Size: 2.8 x 2.9 x 1.2mm) |

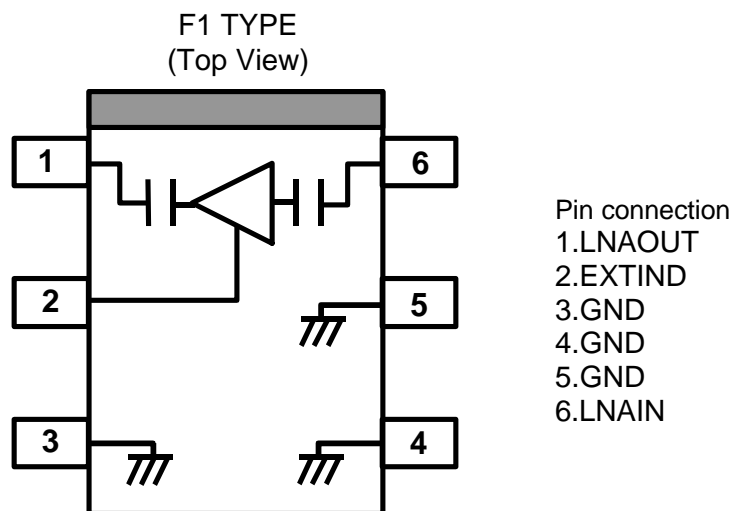
■PIN CONFIGURATION

Note: is package orientation mark.

NJG1103F1

■ABSOLUTE MAXIMUM RATINGS

($T_a=+25^{\circ}\text{C}$, $Z_s=Z_l=50\Omega$)

| PARAMETER | SYMBOL | CONDITIONS | RATINGS | UNITS |
|-----------------------|-----------|----------------------|----------|--------------------|
| Drain Voltage | V_{DD} | | 5.0 | V |
| Input Power | P_{in} | $V_{DD}=2.7\text{V}$ | +10 | dBm |
| Power Dissipation | P_D | | 150 | mW |
| Operating Temperature | T_{opr} | | -40~+85 | $^{\circ}\text{C}$ |
| Storage Temperature | T_{stg} | | -55~+125 | $^{\circ}\text{C}$ |

■ELECTRICAL CHARACTERISTICS 1 (1.5GHz Band)

($V_{DD}=2.7\text{V}$, $f=1.489\text{GHz}$, $T_a=+25^{\circ}\text{C}$, $Z_s=Z_l=50\Omega$, Circuit: Application 1)

| PARAMETER | SYMBOL | CONDITIONS | MIN | TYP | MAX | UNITS |
|------------------------------------|------------|-----------------------------|-------|-------|-------|-------|
| Operating Frequency | freq1 | | 1.470 | 1.489 | 1.520 | GHz |
| Drain Voltage | V_{DD} | | 2.5 | 2.7 | 4.5 | V |
| Operating Current | I_{DD} | RF OFF | - | 3.0 | 3.8 | mA |
| Small Signal Gain | Gain | | 14.0 | 16.0 | 18.0 | dB |
| Gain Flatness | G_{flat} | $f=1.47\sim 1.52\text{GHz}$ | - | 0.5 | 1.0 | dB |
| Noise Figure | NF | | - | 1.2 | 1.4 | dB |
| Pout at 1dB Gain Compression point | P_{-1dB} | | -6.0 | -2.0 | - | dBm |
| Input 3rd Order Intercept Point | IIP3 | $f=1.489+1.4891\text{GHz}$ | -7.0 | -4.0 | - | dBm |
| LNAIN Port VSWR | $VSWR_i$ | | - | 2.0 | 3.0 | |
| LNAOUT Port VSWR | $VSWR_o$ | | - | 2.0 | 3.0 | |

■ELECTRICAL CHARACTERISTICS 2 (1.9GHz Band)

($V_{DD}=2.7\text{V}$, $f=1.9\text{GHz}$, $T_a=+25^{\circ}\text{C}$, $Z_s=Z_l=50\Omega$, Circuit: Application 2)

| PARAMETER | SYMBOL | CONDITIONS | MIN | TYP | MAX | UNITS |
|------------------------------------|------------|-----------------------------|------|------|------|-------|
| Operating Frequency | freq2 | | 1.89 | 1.90 | 1.92 | GHz |
| Drain Voltage | V_{DD} | | 2.5 | 2.7 | 4.5 | V |
| Operating Current | I_{DD} | RF OFF | - | 3.0 | 3.8 | mA |
| Small Signal Gain | Gain | | 12.0 | 14.0 | 16.0 | dB |
| Gain Flatness | G_{flat} | $f=1.89\sim 1.92\text{GHz}$ | - | 0.5 | 1.0 | dB |
| Noise Figure | NF | | - | 1.4 | 1.6 | dB |
| Pout at 1dB Gain Compression point | P_{-1dB} | | -4.5 | -0.5 | - | dBm |
| Input 3rd Order Intercept Point | IIP3 | $f=1.9+1.9001\text{GHz}$ | -6.0 | -3.0 | - | dBm |
| LNAIN Port VSWR | $VSWR_i$ | | - | 2.0 | 3.0 | |
| LNAOUT Port VSWR | $VSWR_o$ | | - | 2.0 | 3.0 | |

■ TYPICAL CHARACTERISTICS (1.5GHz Band)

NF, Gain vs. frequency

($V_{DD}=2.7V, I_{DD}=3.0mA$)

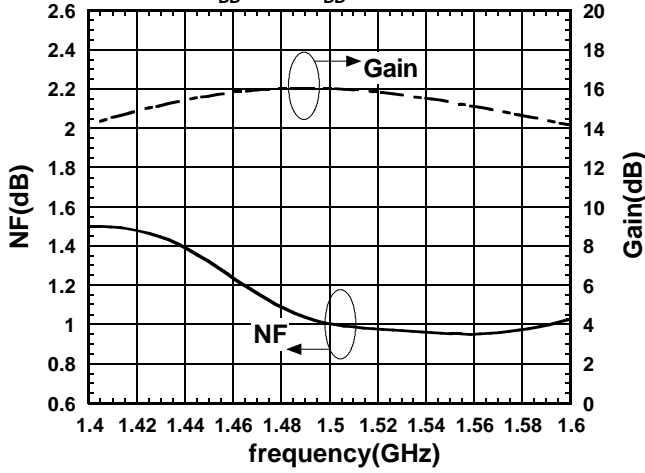

S21, S11, S22, S12 vs. frequency

($V_{DD}=2.7V, I_{DD}=3.0mA$)

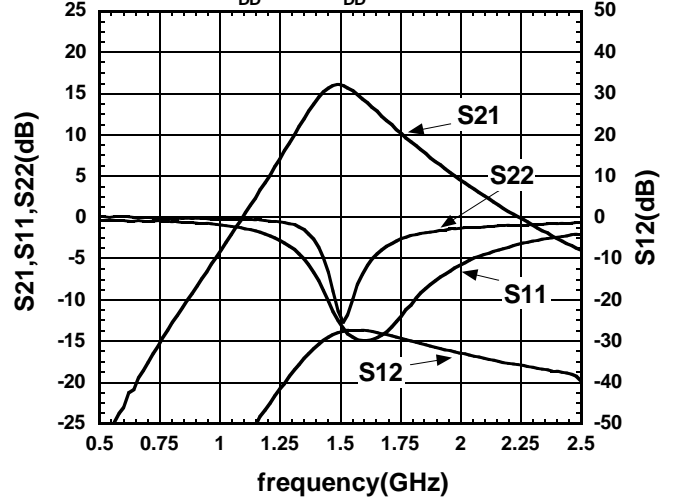

Pin vs. Pout

($V_{DD}=2.7V, I_{DD}=3.0mA, freq=1.489GHz$)

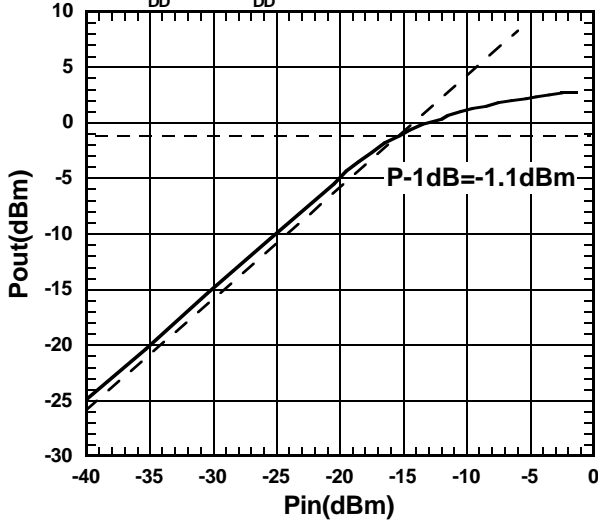

Pin vs. Pout, IM3

($V_{DD}=2.7V, I_{DD}=3.0mA, f=1489+1489.1MHz$)

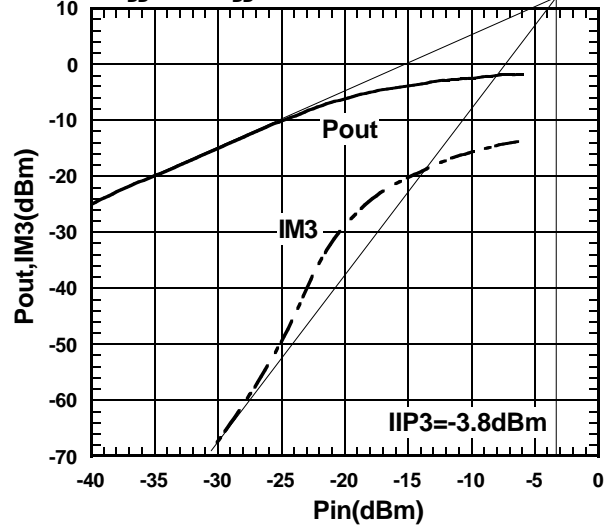

Gain vs. V_{DD}

($f=1.489GHz$)

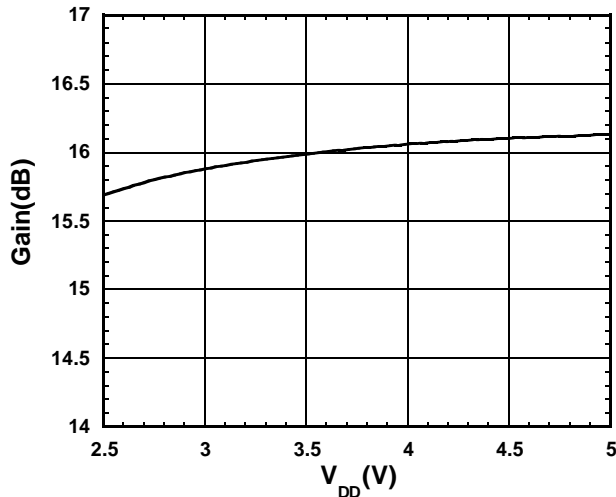

NF, I_{DD} vs. V_{DD}

($f=1.489GHz$)

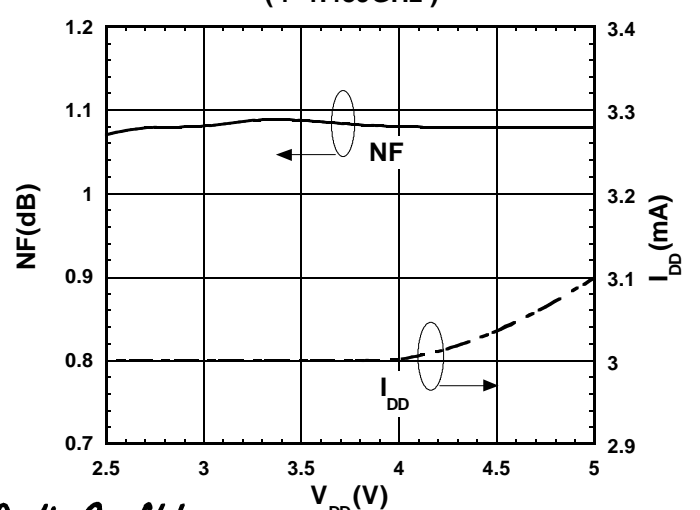

NJG1103F1

■ TYPICAL CHARACTERISTICS (1.5GHz Band)

P-1dB vs. V_{DD}
($f=1.489\text{GHz}$)

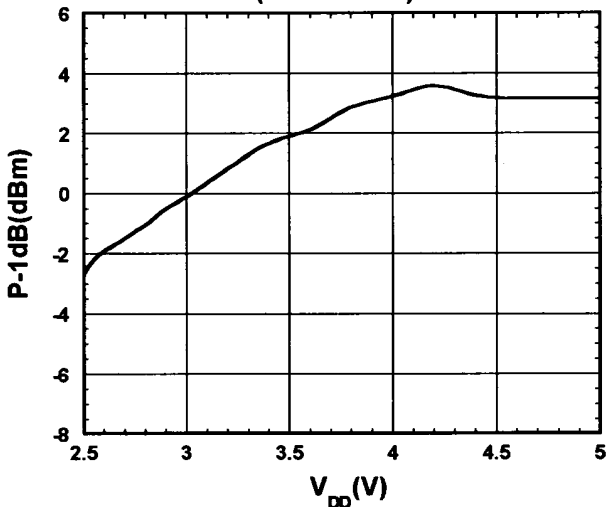

OIP3, IIP3 vs. V_{DD}

($f=1.489+1.4891\text{GHz}, P_{in}=-30\text{dBm}$)

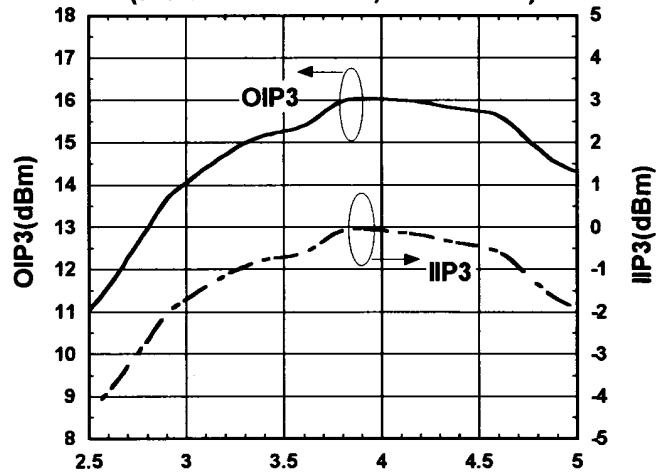

Gain, I_{DD} vs. Temperature

($V_{DD}=2.7\text{V}, f=1.489\text{GHz}$)

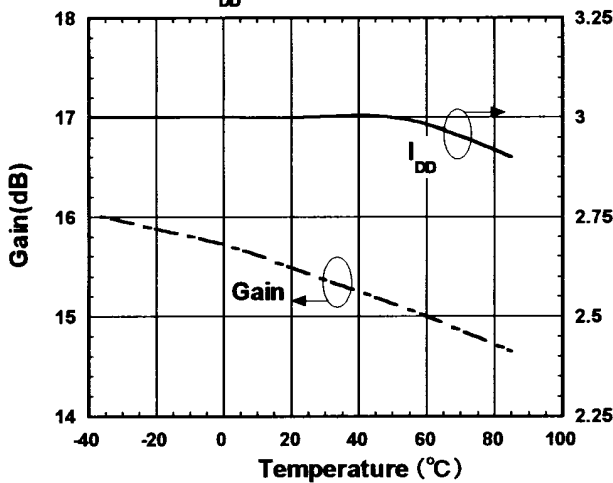

NF, P-1dB vs. V_{DD} , Temperature

($V_{DD}=2.7\text{V}, f=1.489\text{GHz}$)

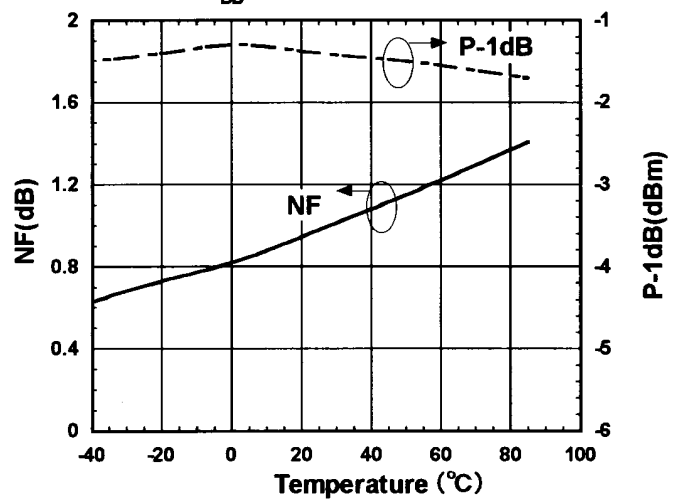

IIP3, OIP3 vs. Temperature

($V_{DD}=2.7\text{V}, I_{DD}=3.0\text{mA}, f=1489.0+1489.1\text{MHz}, P_{in}=-30\text{dBm}$)

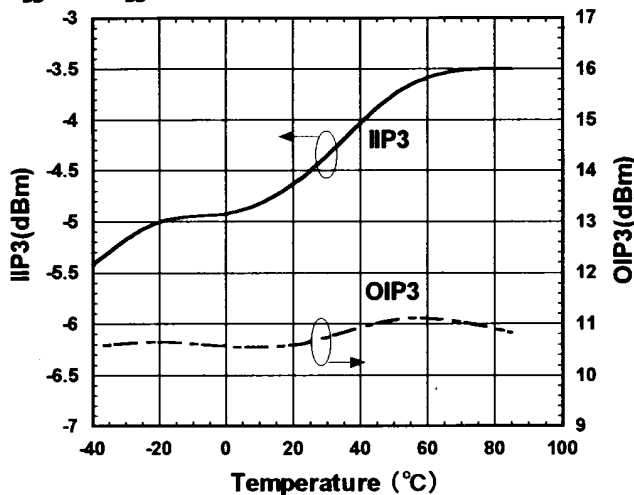

$$OIP3 = \frac{3 \times P_{out} - IM3}{2}$$

$$IIP3 = OIP3 - \text{Gain} \quad @P_{in} = -30\text{dBm}$$

■ TYPICAL CHARACTERISTICS (1.5GHz Band)

S21 vs. frequency(~20GHz)

($V_{DD}=2.7V, I_{DD}=3.0mA$)

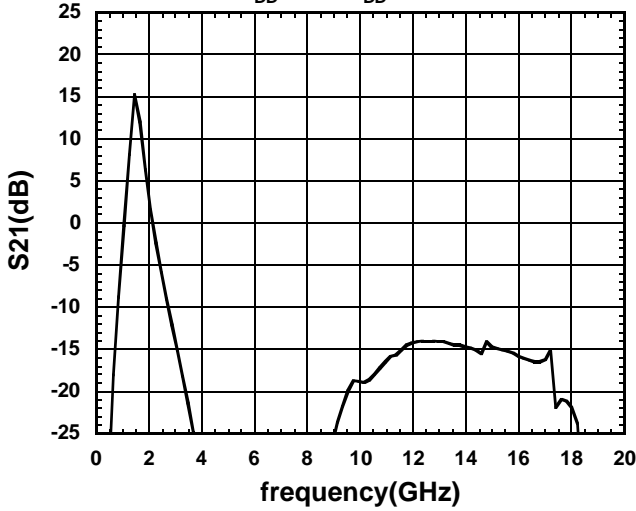

S12 vs. frequency(~20GHz)

($V_{DD}=2.7V, I_{DD}=3.0mA$)

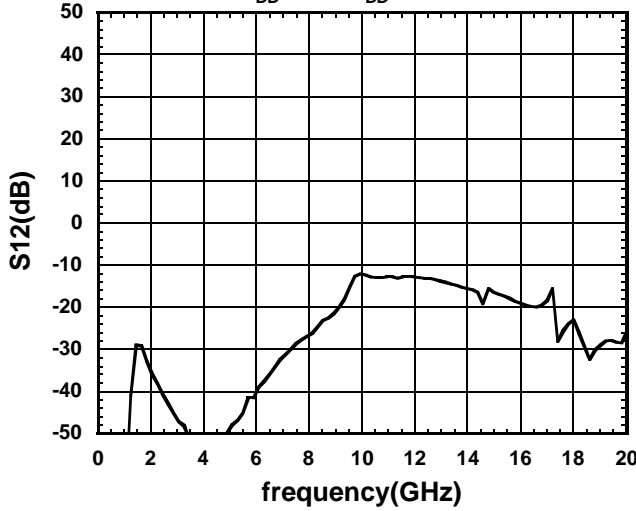

S11 vs. frequency(~20GHz)

($V_{DD}=2.7V, I_{DD}=3.0mA$)

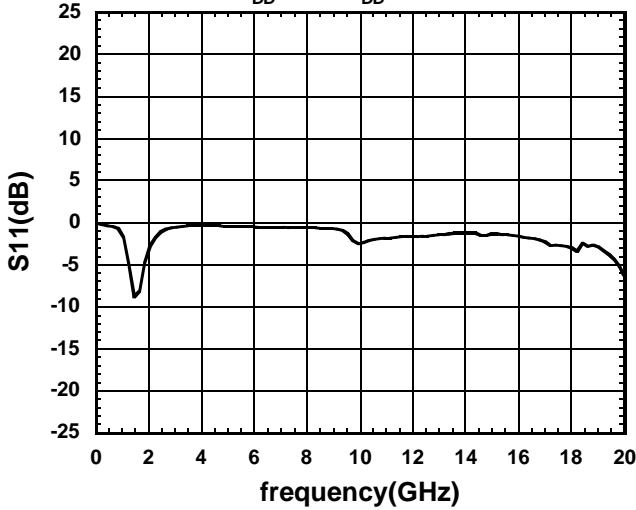

S22 vs. frequency(~20GHz)

($V_{DD}=2.7V, I_{DD}=3.0mA$)

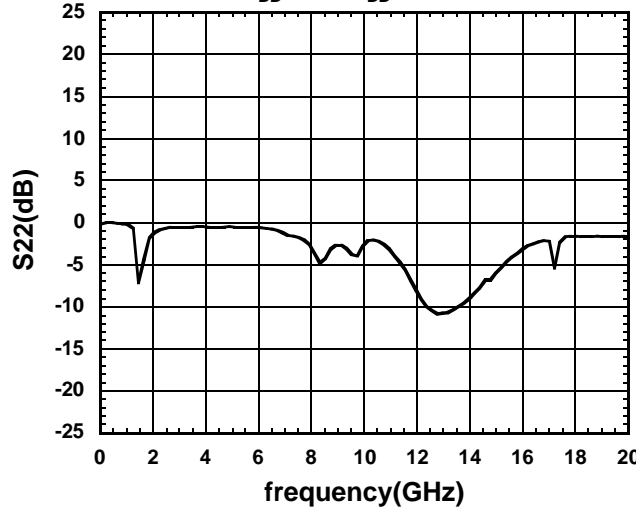

NJG1103F1

■TYPICAL CHARACTERISTICS (1.5GHz Band)

Scattering Parameter Table 1

$V_{DD}=2.7V$, $I_{DD}=3.0mA$, $Z_0=50\Omega$

| Freq (GHz) | S11 | | S21 | | S12 | | S22 | |
|---------------|----------------|--------------|----------------|--------------|----------------|--------------|----------------|--------------|
| | mag (units) | ang (deg) | mag (units) | ang (deg) | mag (units) | ang (deg) | mag (units) | ang (deg) |
| 0.1 | 1.000 | -3.577 | 0.030 | -96.974 | 0.000 | -28.893 | 1.000 | -3.994 |
| 0.2 | 1.000 | -7.804 | 0.008 | 29.498 | 0.001 | 123.060 | 1.000 | -8.157 |
| 0.3 | 1.000 | -11.749 | 0.017 | -17.030 | 0.001 | 90.574 | 1.000 | -11.932 |
| 0.4 | 1.000 | -15.677 | 0.039 | -22.484 | 0.001 | 61.254 | 1.000 | -15.939 |
| 0.5 | 1.000 | -18.892 | 0.069 | -35.493 | 0.002 | 70.970 | 1.000 | -19.427 |
| 0.6 | 1.000 | -22.855 | 0.105 | -43.917 | 0.002 | 68.009 | 1.000 | -23.659 |
| 0.7 | 0.989 | -25.943 | 0.148 | -52.340 | 0.002 | 71.027 | 0.999 | -27.163 |
| 0.8 | 1.000 | -29.192 | 0.211 | -60.102 | 0.002 | 52.546 | 0.999 | -31.190 |
| 0.9 | 0.967 | -32.626 | 0.283 | -68.097 | 0.001 | 54.258 | 0.993 | -34.941 |
| 1.0 | 0.978 | -34.942 | 0.384 | -76.173 | 0.001 | 65.410 | 0.992 | -39.139 |
| 1.1 | 0.952 | -38.109 | 0.517 | -84.022 | 0.001 | -172.907 | 0.990 | -43.543 |
| 1.2 | 0.958 | -40.122 | 0.721 | -92.837 | 0.001 | -143.350 | 0.979 | -48.600 |
| 1.3 | 0.939 | -42.825 | 1.026 | -103.156 | 0.004 | -145.335 | 0.960 | -55.801 |
| 1.4 | 0.944 | -45.403 | 1.595 | -118.935 | 0.008 | -153.556 | 0.893 | -67.092 |
| 1.5 | 0.912 | -49.324 | 2.620 | -147.296 | 0.017 | -174.933 | 0.647 | -88.575 |
| 1.6 | 0.848 | -51.073 | 3.159 | 163.534 | 0.026 | 141.392 | 0.117 | -8.962 |
| 1.7 | 0.835 | -48.490 | 2.335 | 124.924 | 0.023 | 107.004 | 0.638 | -2.204 |
| 1.8 | 0.854 | -48.500 | 1.669 | 105.980 | 0.018 | 92.352 | 0.834 | -16.766 |
| 1.9 | 0.859 | -49.077 | 1.305 | 94.208 | 0.015 | 84.686 | 0.896 | -24.947 |
| 2.0 | 0.856 | -49.978 | 1.080 | 86.597 | 0.014 | 83.498 | 0.933 | -30.122 |
| 2.1 | 0.858 | -50.862 | 0.930 | 79.499 | 0.013 | 82.364 | 0.941 | -33.659 |
| 2.2 | 0.843 | -51.565 | 0.827 | 74.248 | 0.012 | 82.389 | 0.958 | -36.464 |
| 2.3 | 0.843 | -52.644 | 0.752 | 69.058 | 0.012 | 82.449 | 0.959 | -38.653 |
| 2.4 | 0.825 | -53.066 | 0.693 | 65.124 | 0.012 | 84.137 | 0.969 | -40.685 |
| 2.5 | 0.823 | -54.104 | 0.651 | 60.824 | 0.011 | 87.269 | 0.967 | -42.276 |
| 2.6 | 0.806 | -54.425 | 0.618 | 56.840 | 0.012 | 89.464 | 0.975 | -44.085 |
| 2.7 | 0.805 | -55.530 | 0.592 | 52.933 | 0.012 | 91.483 | 0.974 | -45.755 |
| 2.8 | 0.793 | -56.240 | 0.567 | 49.451 | 0.013 | 93.498 | 0.980 | -47.284 |
| 2.9 | 0.783 | -57.285 | 0.550 | 45.760 | 0.013 | 92.174 | 0.975 | -48.847 |
| 3.0 | 0.778 | -58.456 | 0.536 | 41.775 | 0.013 | 94.705 | 0.980 | -50.377 |

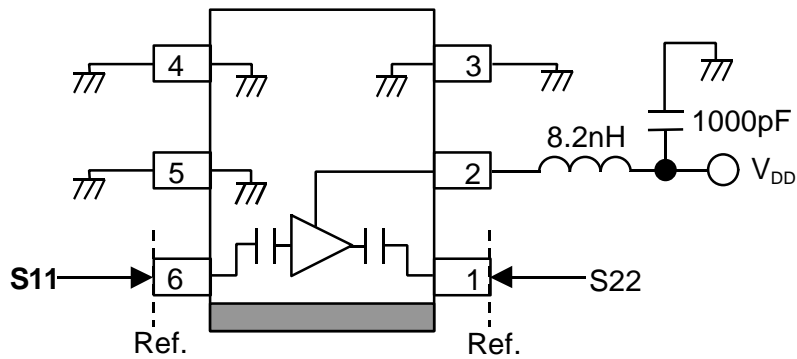

Scattering Parameter Evaluation Circuit

■ TYPICAL CHARACTERISTICS (1.9GHz Band)

NF, Gain vs. frequency

($V_{DD}=2.7V, I_{DD}=3.0mA$)

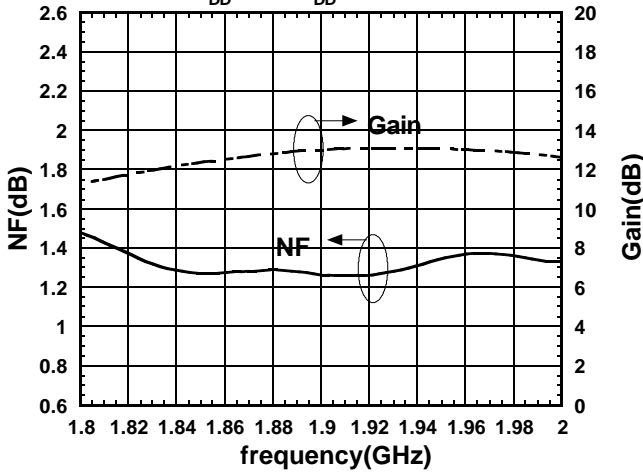

S21, S11, S22, S12 vs. frequency

($V_{DD}=2.7V, I_{DD}=3.0mA$)

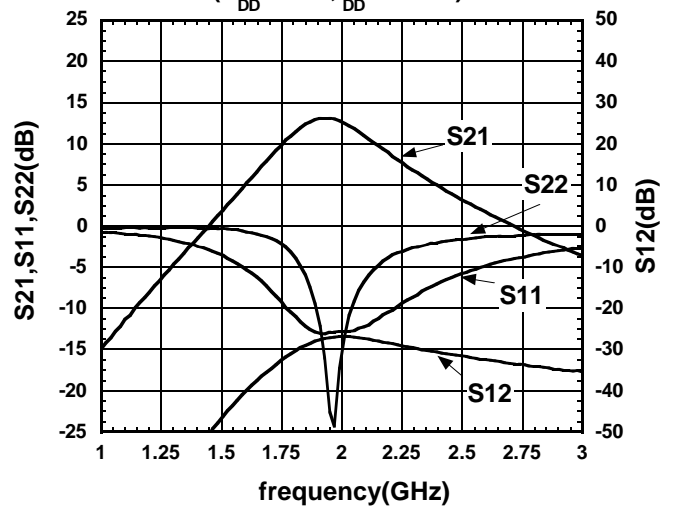

Pin vs. Pout

($V_{DD}=2.7V, I_{DD}=3.0mA, freq=1.9GHz$)

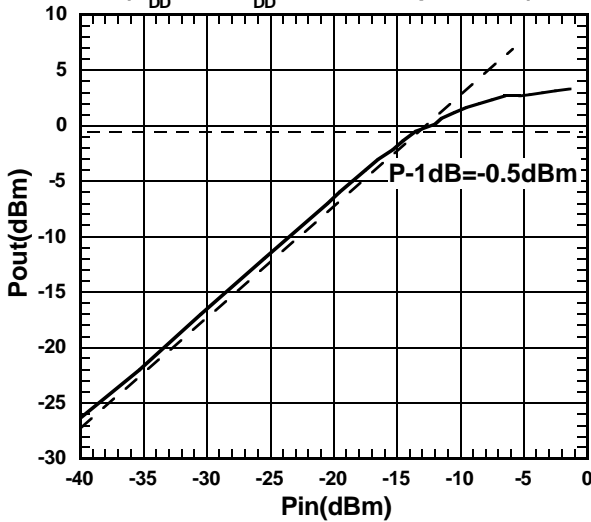

Pin vs. Pout, IM3

($V_{DD}=2.7V, I_{DD}=3.0mA, f=1900+1900.1MHz$)

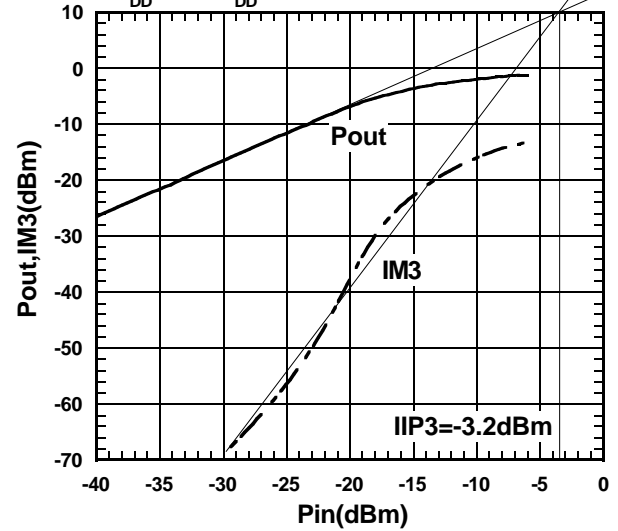

Gain vs. V_{DD}

($f=1.9GHz$)

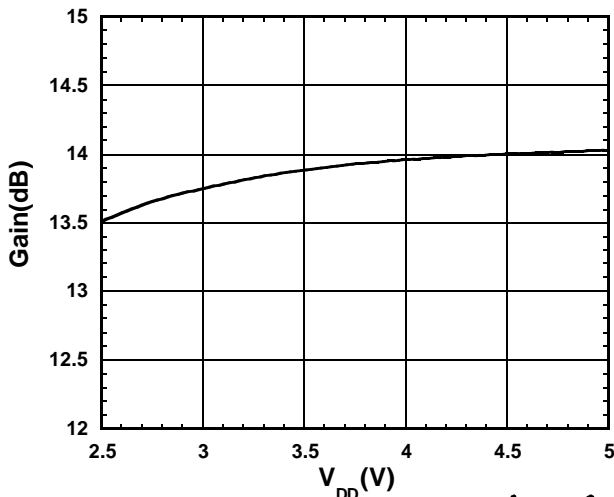

NF, I_{DD} vs. V_{DD}

($f=1.9GHz$)

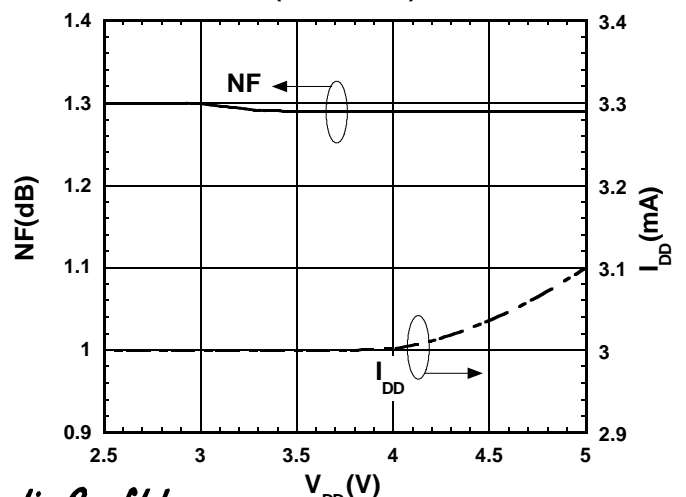

NJG1103F1

■ TYPICAL CHARACTERISTICS (1.9GHz Band)

P-1dB vs. V_{DD}
($f=1.9\text{GHz}$)

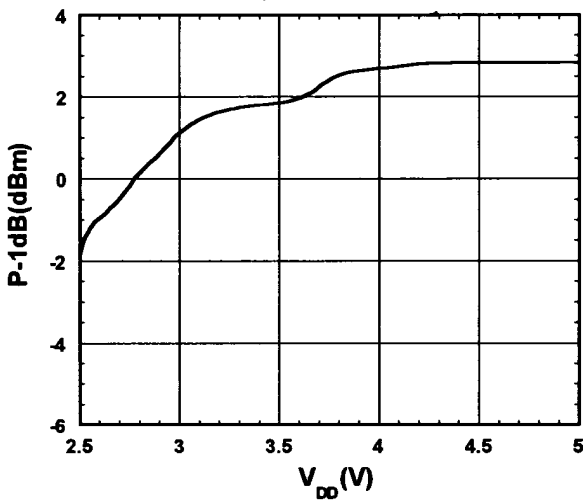

OIP3, IIP3 vs. V_{DD}
($f=1.9+1.9001\text{GHz}, P_{in}=-30\text{dBm}$)

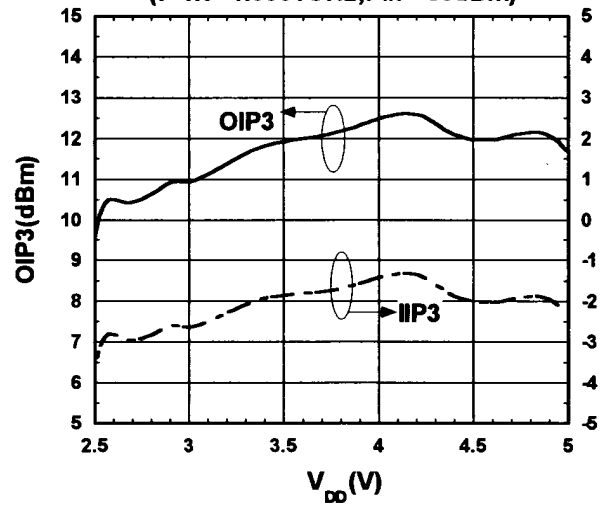

Gain, I_{DD} vs. Temperature
($V_{DD}=2.7\text{V}, f=1.9\text{GHz}$)

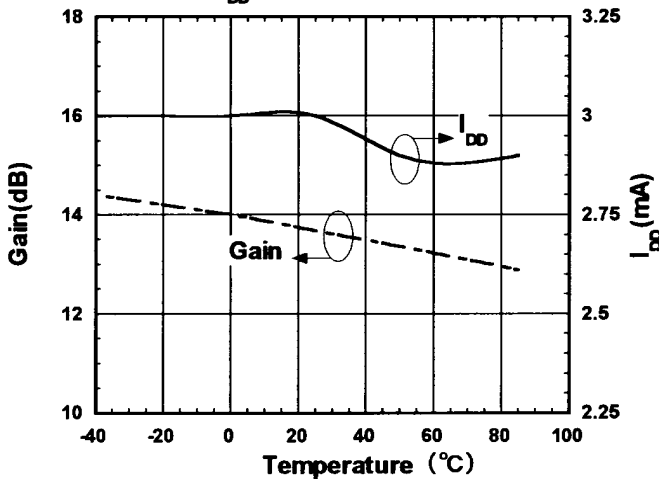

NF, P-1dB vs. Temperature
($V_{DD}=2.7\text{V}, f=1.9\text{GHz}$)

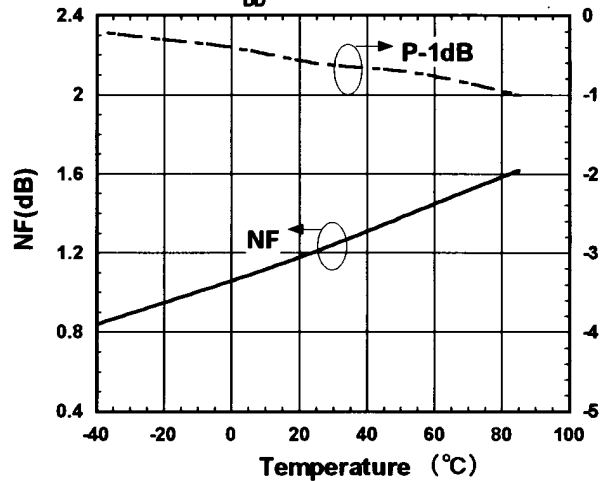

IIP3, OIP3 vs. Temperature

($V_{DD}=2.7\text{V}, I_{DD}=3.0\text{mA}, f=1.9+1.9001\text{GHz}, P_{in}=-30\text{dBm}$)

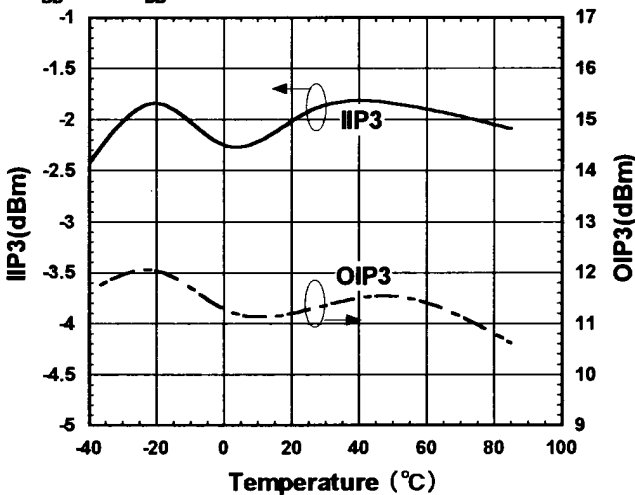

$$OIP3 = \frac{3 \times P_{out} - IM3}{2}$$

$$IIP3 = OIP3 - \text{Gain} \quad @ P_{in} = -30\text{dBm}$$

■ TYPICAL CHARACTERISTICS (1.9GHz Band)

S21 vs. frequency(~20GHz)

($V_{DD}=2.7V, I_{DD}=3.0mA$)

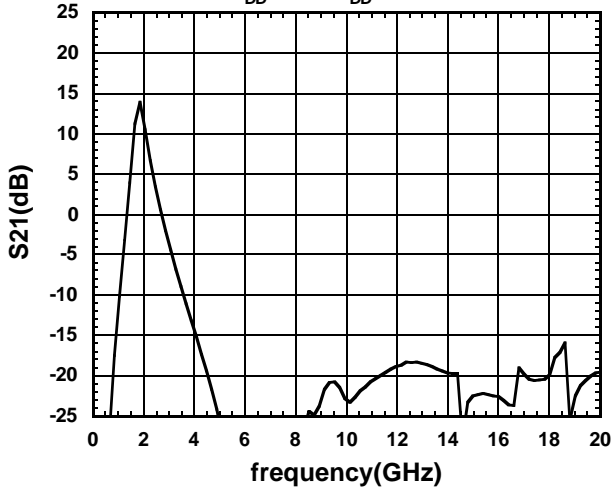

S12 vs. frequency(~20GHz)

($V_{DD}=2.7V, I_{DD}=3.0mA$)

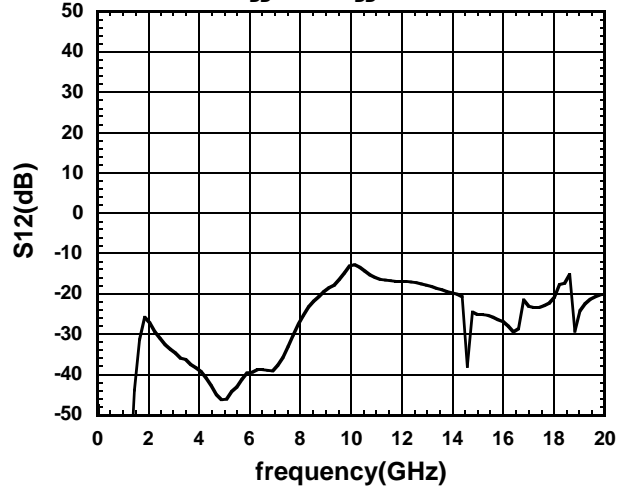

S11 vs. frequency(~20GHz)

($V_{DD}=2.7V, I_{DD}=3.0mA$)

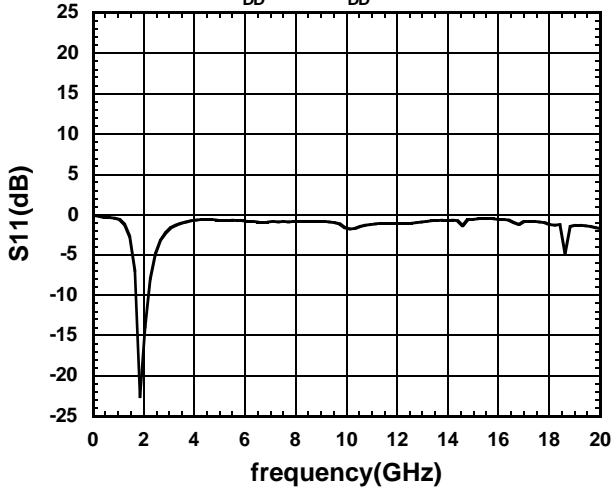

S22 vs. frequency(~20GHz)

($V_{DD}=2.7V, I_{DD}=3.0mA$)

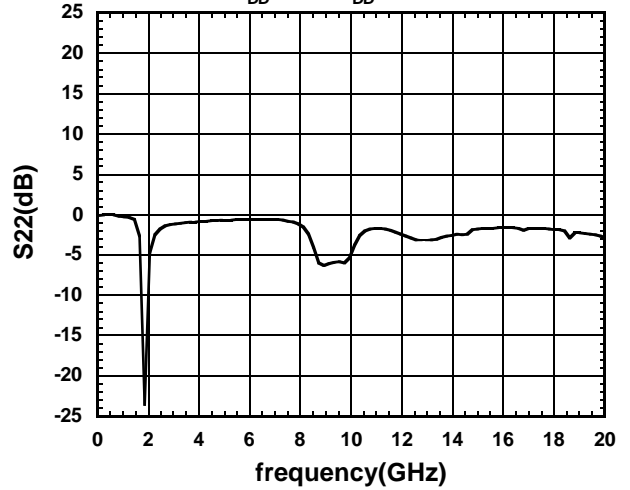

NJG1103F1

■TYPICAL CHARACTERISTICS (1.9GHz Band)

Scattering Parameter Table 2

$V_{DD}=2.7V$, $I_{DD}=3.0mA$, $Z_0=50\Omega$

| Freq (GHz) | S11 | | S21 | | S12 | | S22 | |
|---------------|----------------|--------------|----------------|--------------|----------------|--------------|----------------|--------------|
| | mag (units) | ang (deg) | mag (units) | ang (deg) | mag (units) | ang (deg) | mag (units) | ang (deg) |
| 0.1 | 1.000 | -3.466 | 0.013 | -99.853 | 0.001 | -40.688 | 1.000 | -3.792 |
| 0.2 | 1.000 | -7.836 | 0.003 | 120.878 | 0.000 | 111.001 | 1.000 | -7.797 |
| 0.3 | 1.000 | -11.376 | 0.011 | -23.230 | 0.001 | 77.901 | 1.000 | -11.547 |
| 0.4 | 1.000 | -15.369 | 0.024 | -31.645 | 0.001 | 60.826 | 1.000 | -15.222 |
| 0.5 | 1.000 | -18.524 | 0.045 | -34.983 | 0.002 | 73.639 | 1.000 | -18.774 |
| 0.6 | 1.000 | -22.254 | 0.068 | -44.466 | 0.002 | 64.832 | 1.000 | -22.517 |
| 0.7 | 0.987 | -25.261 | 0.096 | -51.466 | 0.002 | 59.880 | 0.998 | -25.988 |
| 0.8 | 0.994 | -28.510 | 0.134 | -58.880 | 0.002 | 62.909 | 0.997 | -29.586 |
| 0.9 | 0.962 | -31.527 | 0.173 | -65.887 | 0.002 | 62.762 | 0.994 | -32.980 |
| 1.0 | 0.972 | -33.806 | 0.227 | -72.166 | 0.001 | 64.214 | 0.994 | -36.537 |
| 1.1 | 0.946 | -36.765 | 0.287 | -80.123 | 0.001 | 59.903 | 0.993 | -40.081 |
| 1.2 | 0.951 | -38.499 | 0.370 | -86.666 | 0.000 | 104.075 | 0.990 | -43.600 |
| 1.3 | 0.931 | -40.743 | 0.466 | -93.543 | 0.001 | -144.742 | 0.987 | -47.623 |
| 1.4 | 0.936 | -42.455 | 0.612 | -101.148 | 0.002 | -131.875 | 0.979 | -52.301 |
| 1.5 | 0.922 | -44.128 | 0.816 | -109.855 | 0.004 | -140.321 | 0.962 | -58.048 |
| 1.6 | 0.927 | -46.084 | 1.122 | -120.983 | 0.007 | -150.577 | 0.927 | -66.488 |
| 1.7 | 0.915 | -48.182 | 1.603 | -137.240 | 0.012 | -161.035 | 0.830 | -79.157 |
| 1.8 | 0.900 | -50.392 | 2.281 | -162.468 | 0.018 | -178.320 | 0.584 | -100.354 |
| 1.9 | 0.853 | -51.550 | 2.711 | 159.780 | 0.026 | 152.338 | 0.052 | -128.112 |
| 2.0 | 0.829 | -50.493 | 2.315 | 125.880 | 0.026 | 124.607 | 0.468 | 12.049 |
| 2.1 | 0.835 | -49.844 | 1.803 | 104.689 | 0.023 | 107.196 | 0.718 | -6.837 |
| 2.2 | 0.829 | -49.732 | 1.426 | 91.557 | 0.020 | 99.244 | 0.827 | -17.772 |
| 2.3 | 0.834 | -50.427 | 1.192 | 82.277 | 0.018 | 94.680 | 0.876 | -24.741 |
| 2.4 | 0.821 | -50.628 | 1.027 | 75.650 | 0.017 | 92.857 | 0.906 | -29.743 |
| 2.5 | 0.821 | -51.483 | 0.922 | 69.553 | 0.016 | 91.557 | 0.920 | -33.371 |
| 2.6 | 0.806 | -51.476 | 0.841 | 64.184 | 0.015 | 91.315 | 0.934 | -36.756 |
| 2.7 | 0.805 | -52.354 | 0.782 | 59.683 | 0.015 | 91.885 | 0.939 | -39.453 |
| 2.8 | 0.798 | -52.928 | 0.731 | 55.213 | 0.014 | 91.583 | 0.947 | -41.774 |
| 2.9 | 0.786 | -53.597 | 0.692 | 51.129 | 0.015 | 95.367 | 0.945 | -43.991 |
| 3.0 | 0.784 | -54.637 | 0.665 | 46.939 | 0.015 | 101.051 | 0.955 | -46.322 |

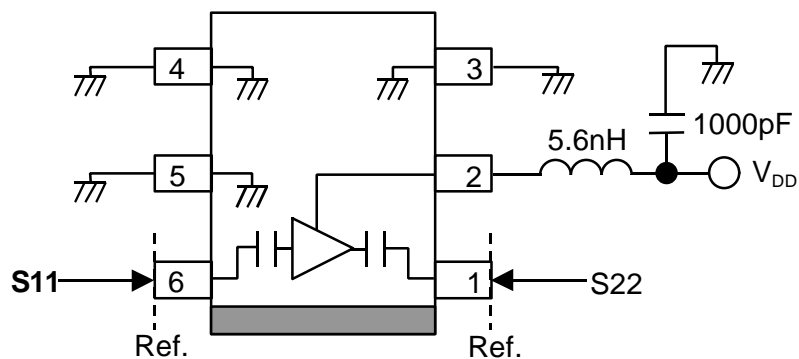

Scattering Parameter Evaluation Circuit

RECOMMEND CIRCUIT 1 (1.5GHz Band)

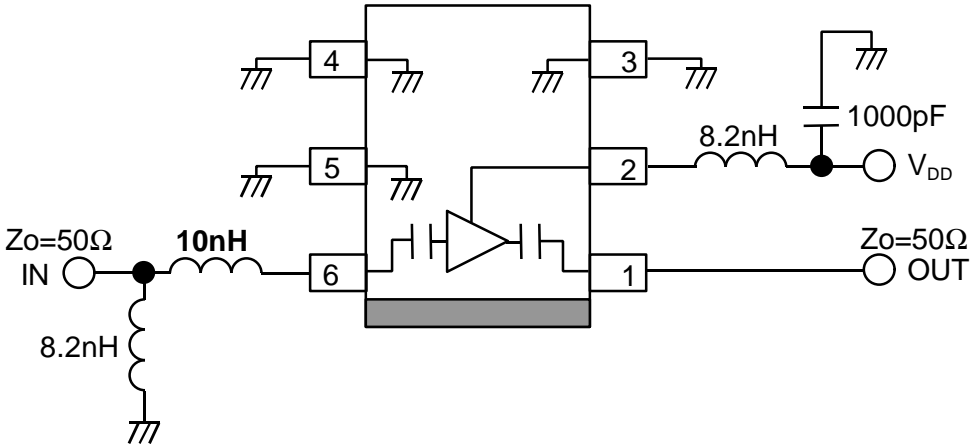

RECOMMEND CIRCUIT 2 (1.9GHz Band)

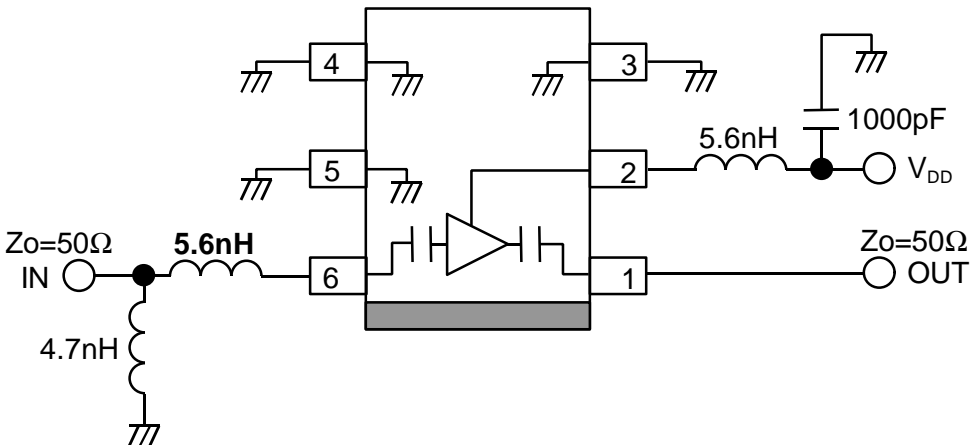

NJG1103F1

RECOMMENDED PCB DESIGN

(Top View)

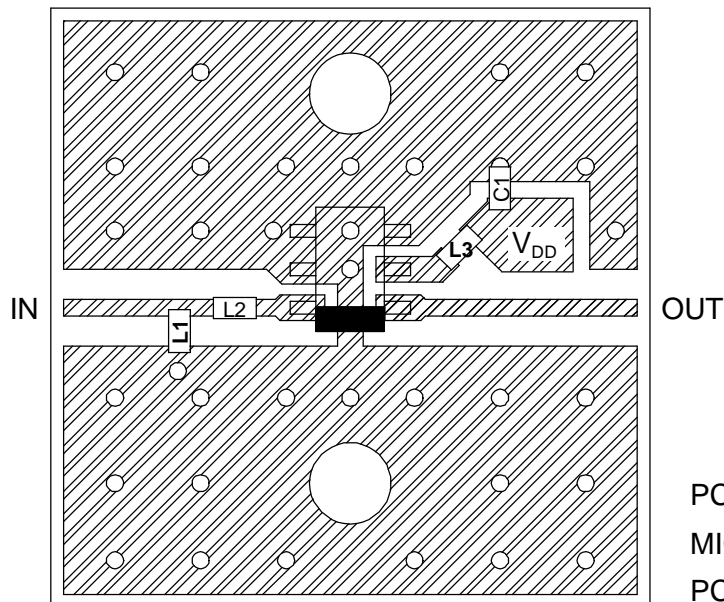

PCB : FR4, t=0.2mm

MICROSTRIP LINE WIDTH=0.4mm($Z_0=50\Omega$)

PCB SIZE : 14.0x14.0mm

PARTS LIST

| PARTS ID | 1.5GHz | 1.9GHz | COMMENT |
|----------|--------|--------|----------------------|
| L1 | 8.2nH | 4.7nH | TAIYO-YUDEN (HK1005) |
| L2 | 10nH | 5.6nH | TAIYO-YUDEN (HK1005) |
| L3 | 8.2nH | 5.6nH | TAIYO-YUDEN (HK1005) |
| C1 | 1000pF | 1000pF | MURATA (GRM36) |

■PACKAGE OUTLINE (MTP6-1)

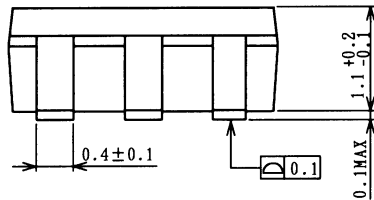
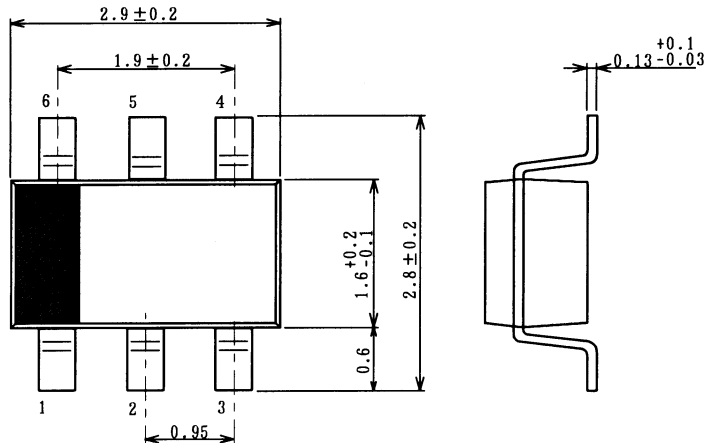

| | |
|---------------------|------------------|
| Lead material | : Copper |
| Lead surface finish | : Solder plating |
| Molding material | : Epoxy resin |
| UNIT | : mm |
| Weight | : 15mg |

Cautions on using this product

This product contains Gallium-Arsenide (GaAs) which is a harmful material.

- Do NOT eat or put into mouth.
- Do NOT dispose in fire or break up this product.
- Do NOT chemically make gas or powder with this product.
- To waste this product, please obey the relating law of your country.

[CAUTION]

The specifications on this databook are only given for information, without any guarantee as regards either mistakes or omissions. The application circuits in this databook are described only to show representative usages of the product and not intended for the guarantee or permission of any right including the industrial rights.

This product may be damaged with electric static discharge (ESD) or spike voltage. Please handle with care to avoid these damages.

X-ON Electronics

Largest Supplier of Electrical and Electronic Components

Click to view similar products for [RF Amplifier](#) category:

Click to view products by [NJR](#) manufacturer:

Other Similar products are found below :

[ADPA7006AEHZ](#) [CXE2089ZSR](#) [MGA-43828-BLKG](#) [A82-1](#) [RF2878TR7](#) [BGA 728L7 E6327](#) [BGB719N7ESDE6327XTMA1](#) [HMC1126-SX](#) [HMC342](#) [HMC405](#) [HMC561-SX](#) [HMC598-SX](#) [HMC-ALH382-SX](#) [HMC-ALH476-SX](#) [SE2433T-R](#) [SE2622L-R](#) [SMA3101-TL-E](#) [SMA39](#) [SMA70-1](#) [A66-1](#) [A66-3](#) [A67-1](#) [LX5535LQ](#) [LX5540LL](#) [HMC3653LP3BETR](#) [HMC395](#) [HMC549MS8GETR](#) [HMC576-SX](#) [HMC754S8GETR](#) [HMC-ALH435-SX](#) [SMA101](#) [SMA181](#) [SMA32](#) [SMA411](#) [SMA531](#) [SST12LP19E-QX6E](#) [TGA2598](#) [WPM0510A](#) [HMC5929LS6TR](#) [HMC5879LS7TR](#) [HMC906A-SX](#) [HMC544A](#) [HMC1126](#) [HMC1110-SX](#) [HMC1087F10](#) [HMC1086](#) [HMC1016](#) [MMZ25332B4T1](#) [AMC-143SMA](#) [MMZ09332BT1](#)