

Headphone Amplifier with Electronic Volume

■ GENERAL DESCRIPTION

NJM2777 is a headphone amplifier with electronic volume. It includes widely gain adjustable volume, +20 to -80 dB, and mute function. These are controlled by DC voltage. The NJM2777 is suitable for headphone output on TV set.

■ PACKAGE OUTLINE

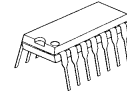

NJM2777D

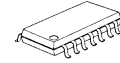

NJM2777M

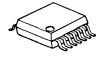

NJM2777V

■ FEATURES

- Operating Voltage 8 to 10 V
- Electronic Volume +20dB to -80dB
- Mute Function
- Bipolar
- Package Outline DIP14, DMP14, SSOP14

■ BLOCK DIAGRAM

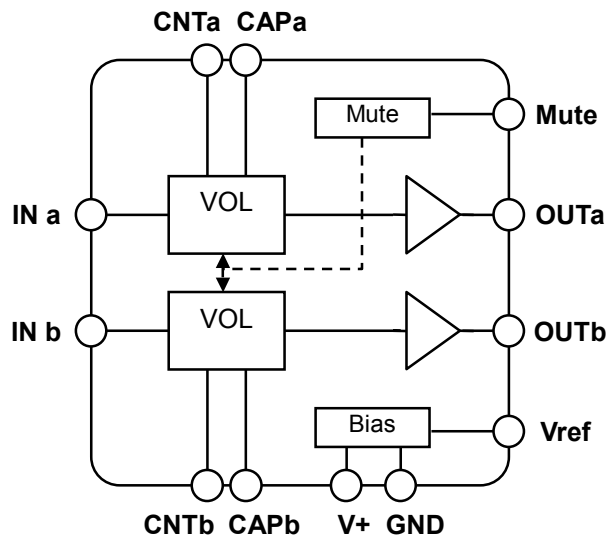

■ PIN FUNCTION

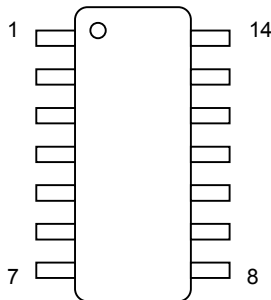

No.	SYMBOL	FUNCTION	No.	SYMBOL	FUNCTION
1	V+	Power Supply	8	N.C.	No connecting
2	OUTb	Bch Output	9	Vref	Reference voltage stabilized capacitor connect terminal
3	CNTb	Bch Volume control voltage input	10	INa	Ach Input
4	CAPb	Bch Volume control click noise absorbing capacitor connect terminal	11	CAPa	Ach Volume control click noise absorbing capacitor connect terminal
5	INb	Bch Input	12	CNTa	Ach Volume control voltage input
6	Mute	Mute control	13	OUTa	Ach Output
7	N.C.	No connecting	14	GND	Ground

■ ABSOLUTE MAXIMUM RATING (Ta=25°C)

PARAMETER	SYMBOL	RATING	UNIT
Supply Voltage	V ⁺	12	V
Power Dissipation	P _D	DIP14 : 500 DMP14 : 500* SSOP14 : 440*	mW
Operating Temperature Range	Topr	-20 to +75	°C
Storage Temperature Range	Tstg	-40 to +125	°C

*(Note) EIA/JEDEC STANDARD Test board(76.2 x 114.3 x 1.6mm, 2layers, FR-4)mounting

■ ELECTRICAL CHARACTERISTICS

(V⁺=9V, V_{IN}=-20dBV, f=1kHz, R_L=100Ω, G_v=0dB, "Mute" terminal =L, Ta=25°C)

●POWER SUPPLY

PARAMETER	SYMBOL	TEST CONDITION	MIN.	TYP.	MAX.	UNIT
Operating Voltage	V ⁺		8	9	10	V
Operating Current	I _{CC}	No Signal	-	5	8	mA
Reference Voltage	V _{REF}		4	4.1	4.2	V

●AMPLIFIER

PARAMETER	SYMBOL	TEST CONDITION	MIN.	TYP.	MAX.	UNIT
Volume Operating Range	G _{EVR}	V _{CNTa} , V _{CNTb} = 0 to 3.3V	80	100	-	dB
Voltage Gain Channel Balance	ΔG _v		-1.5	0	1.5	dB
Maximum Input Voltage	V _{IM}	G _v =-10dB THD=3%	8.9 (2.8)	9.5 (3.0)	-	dBV (V _{rms})
Output Power	P _O	G _v =10dB, THD=10%	70	100	-	mW
Total Harmonic Distortion	THD		-	0.1	1	%
Channel Separation	CS	R _g =600Ω, V _{in} = 0dBV	70	80	-	dB
Mute Level	Mute	"Mute" terminal=H, V _{in} = 0dBV	-	-85	-75	dB
Output Noise Voltage 1	V _{NO1}	R _g =0Ω, A-Weighted	-	-95 (18)	-85 (56)	dBV (μV _{rms})
Output Noise Voltage 2	V _{NO2}	"Mute" terminal =H R _g =0Ω, A-Weighted	-	-105 (5.6)	-95 (18)	dBV (μV _{rms})
Power Supply Ripple Rejection	PSRR	V _{ripple} =-20dBV R _g =0Ω	-	70	-	dB

●CONTROL

PARAMETER	SYMBOL	TEST CONDITION	MIN.	TYP.	MAX.	UNIT
High Level Input Voltage	V _{IH}		2	-	V ⁺	V
Low Level Input Voltage	V _{IL}		0	-	0.4	V

■ CONTROL TERMINAL

Operating Condition	Control Terminal		Description
	Mute Terminal		
Operating Condition	Mute	H	Mute the signal
	Active	L, OPEN	Output the signal

■ TEST CIRCUIT
TEST CIRCUIT1 (THD, GEVR, VIM, PO)

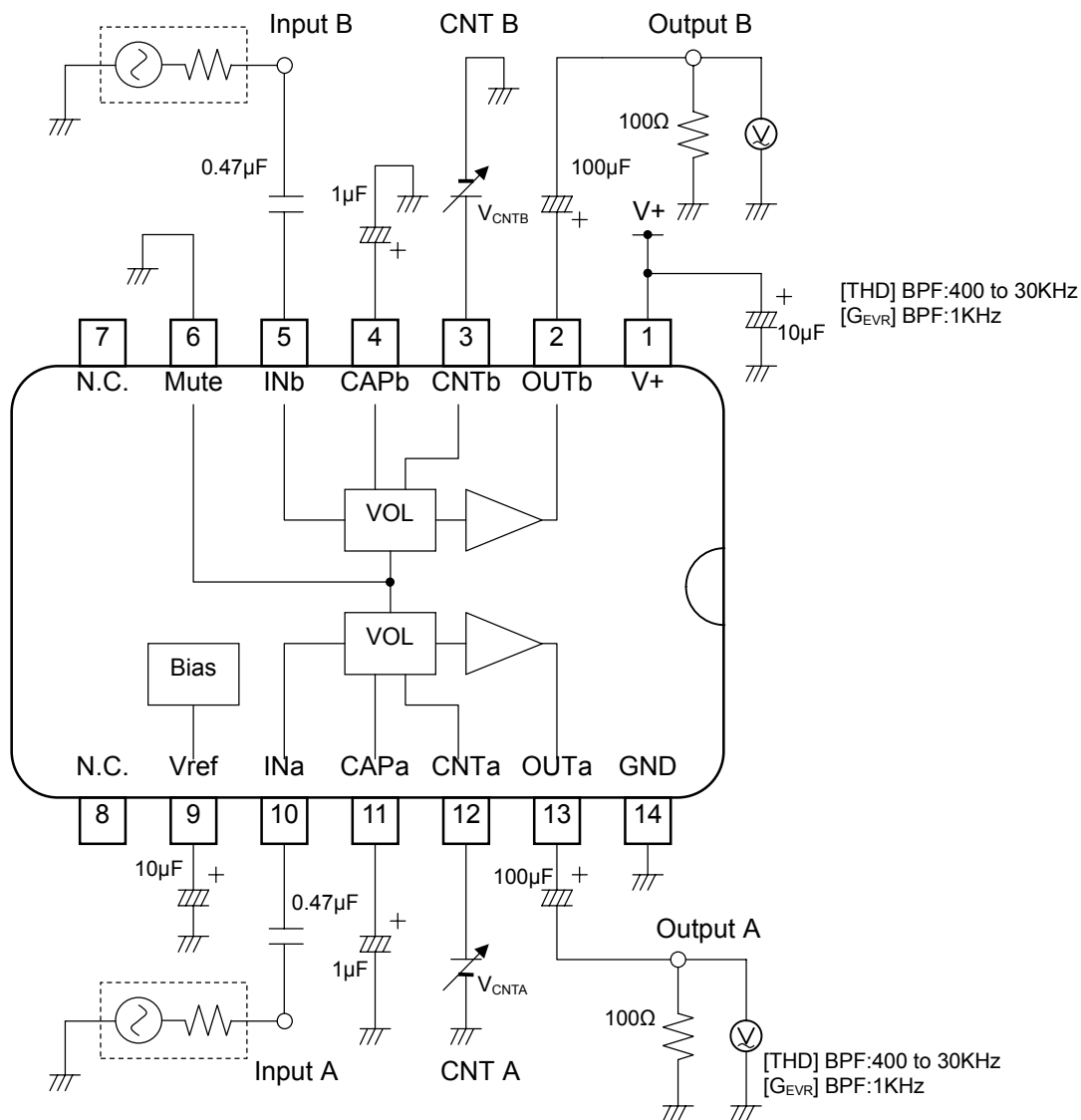

$$\text{Volume Range : } GEVR = 20 \log \frac{V_{o \max}}{V_{o \min}}$$

[$V_{o \min}$: Output voltage at $V_{CNT} = 0V$
 $V_{o \max}$: Output voltage at $V_{CNT} = 3.3V$]

TEST CIRCUIT 2 (VNO1,VNO2,VREF)

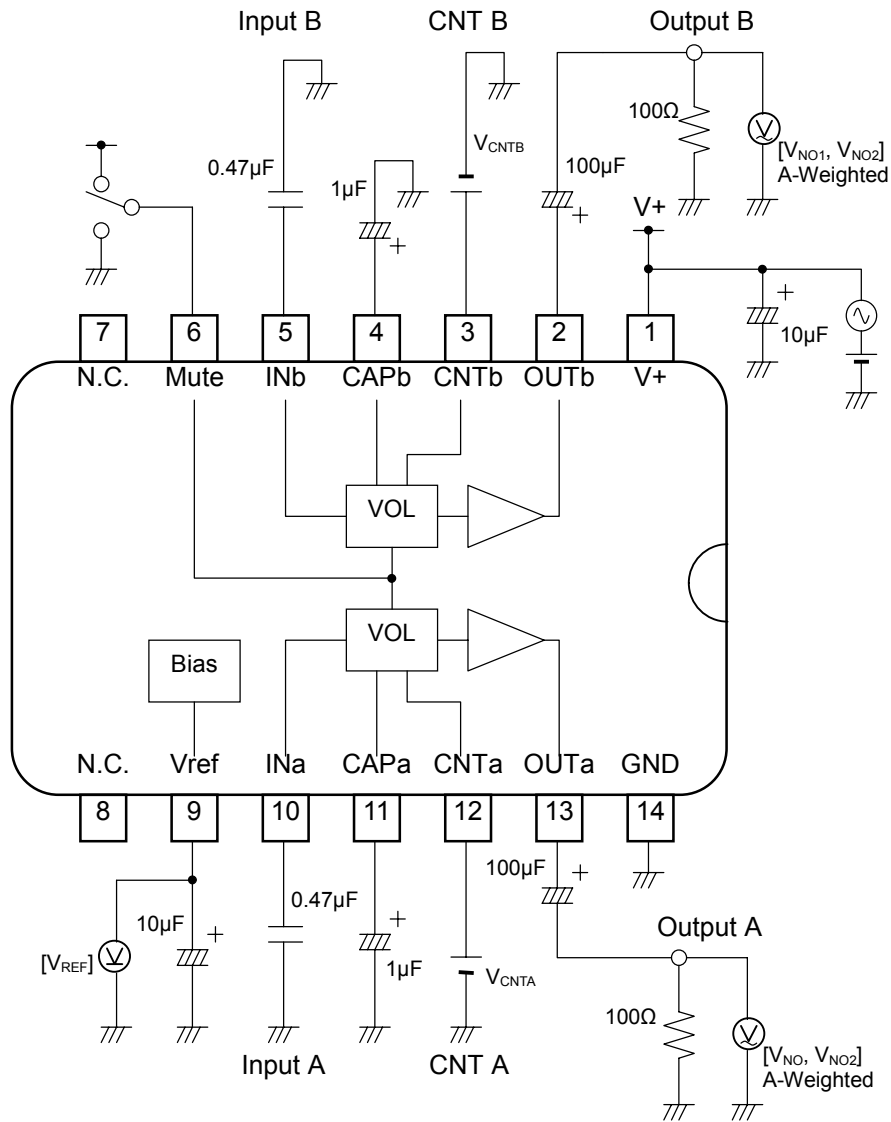

TEST CIRCUIT 3 (I_{CC})

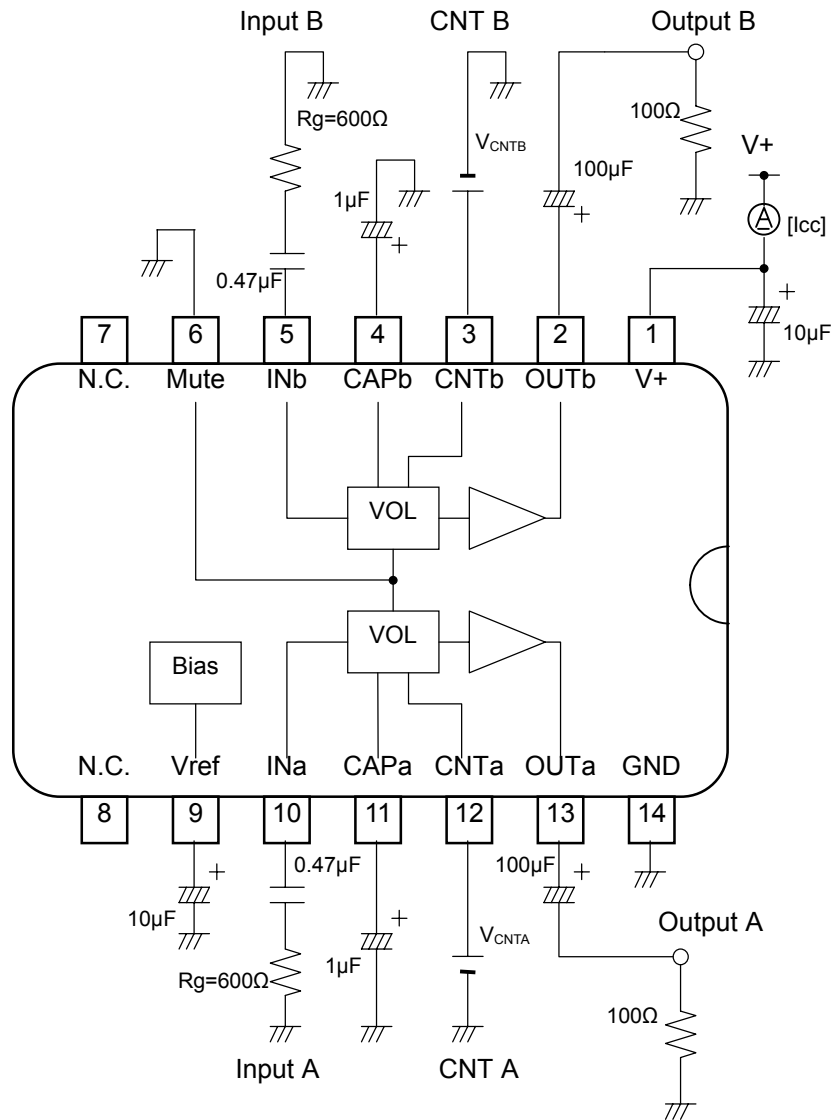

TEST CIRCUIT 4 (CS)

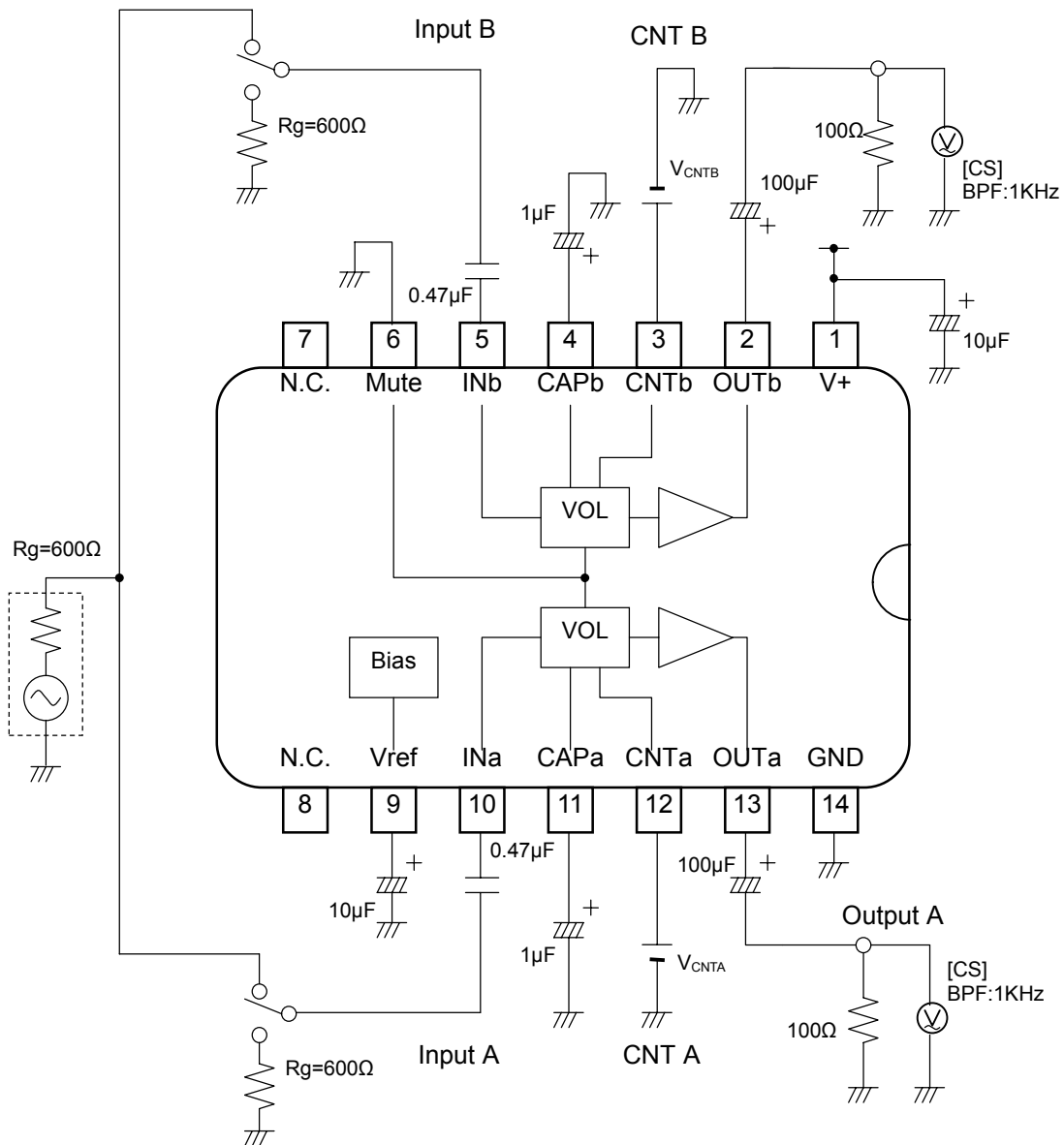

TEST CIRCUIT 5 (PSRR)

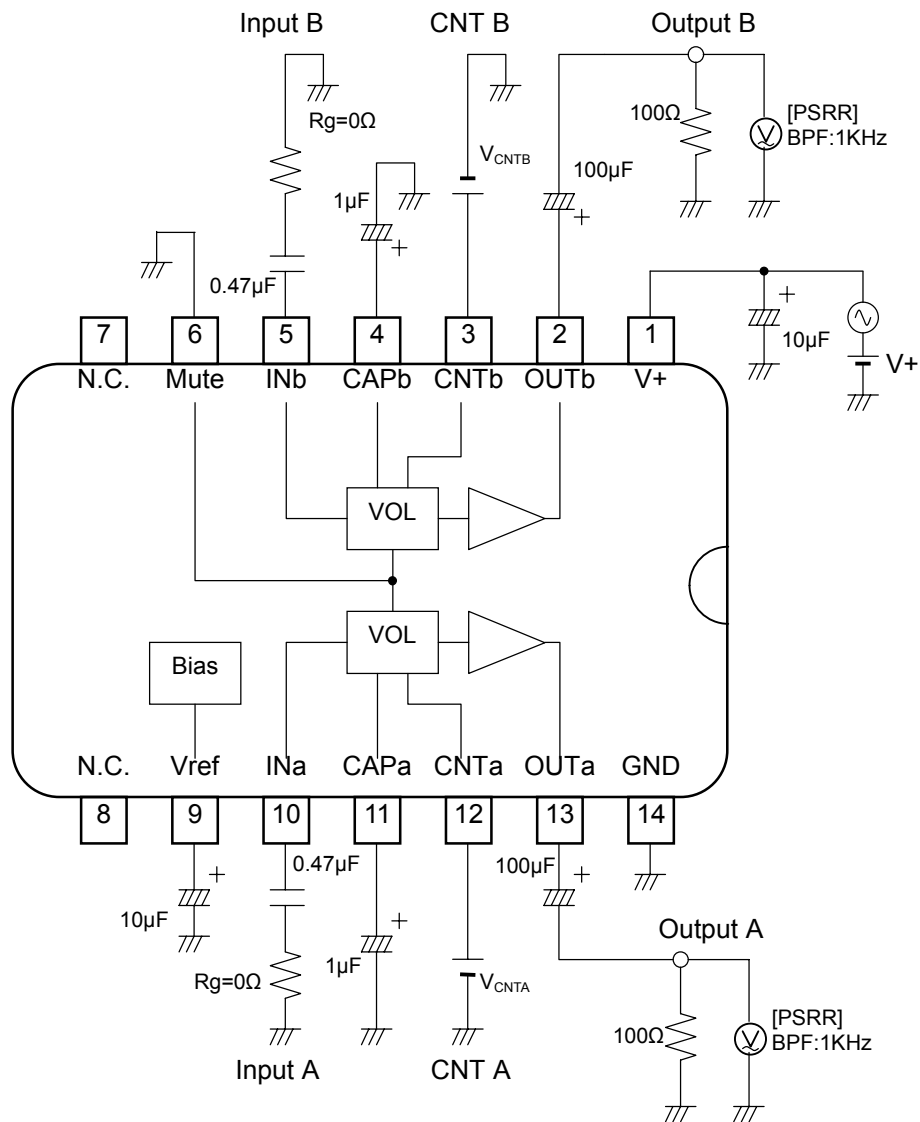

TEST CIRCUIT 6 (MUTE)

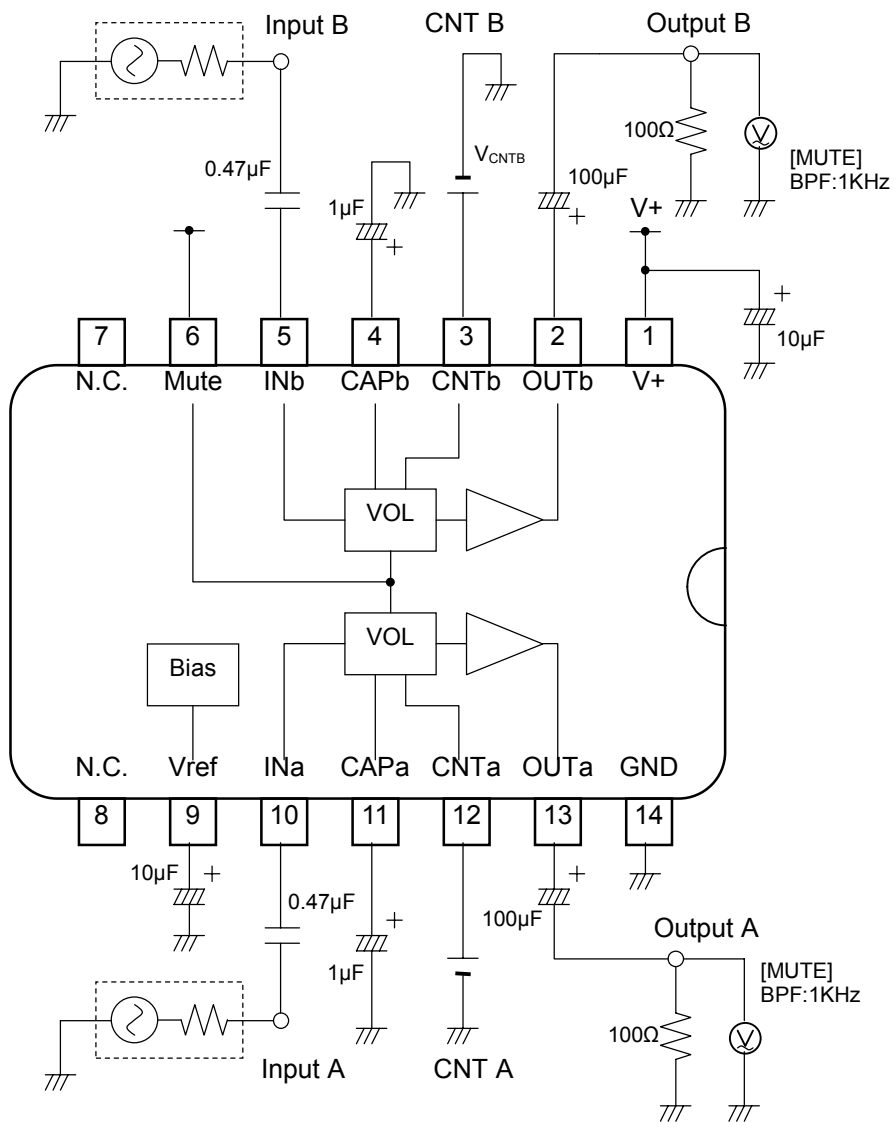

APPLICATION CIRCUIT

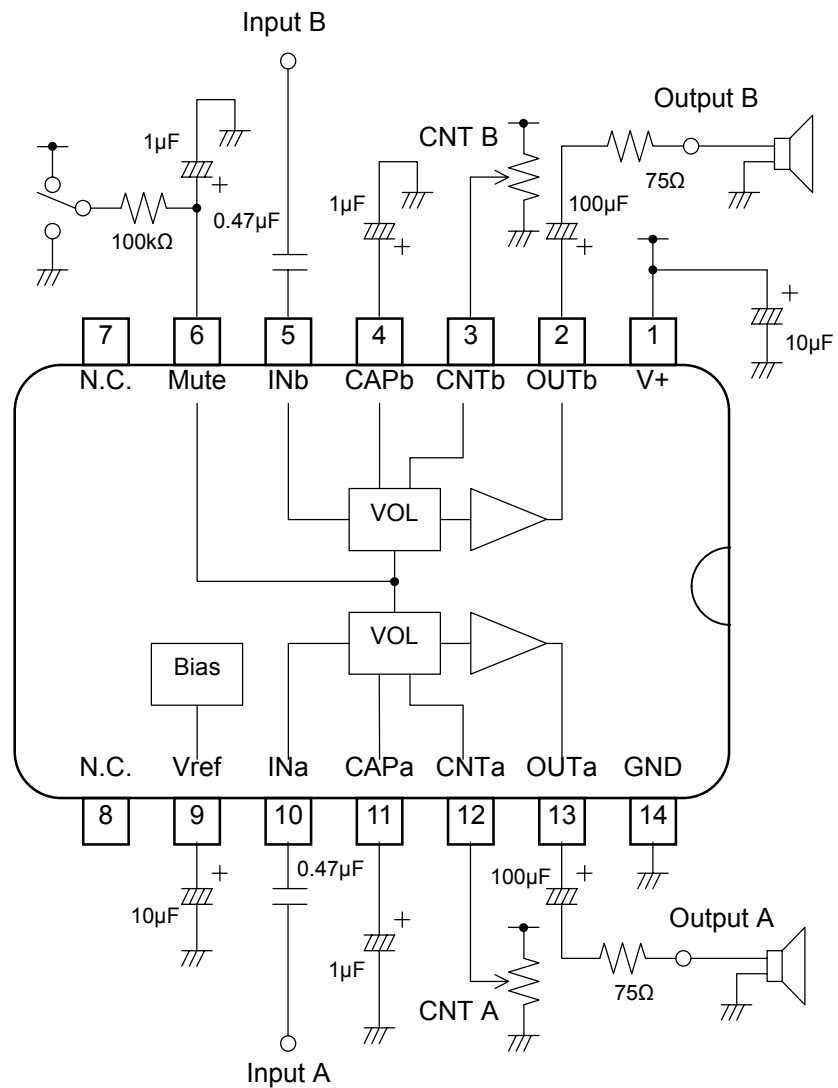

■ TERMINAL DESCRIPTION

PIN NO.	SYMBOL	FUNCTION	EQUIVALENT CIRCUIT	TERMINAL VOLTAGE
2 13	OUTb OUTa	Bch Output Ach Output		V+/2
3 12	CNTb CNTa	Bch Volume Control Ach Volume Control		-
4 11	CAPb CAPa	Bch Volume control click noise absorbing capacitor connect terminal Ach Volume control click noise absorbing capacitor connect terminal		-
5 10	INb INa	Bch Input Ach Input		GND

■ TERMINAL DESCRIPTION

PIN NO.	SYMBOL	FUNCTION	EQUIVALENT CIRCUIT	TERMINAL VOLTAGE
6	Mute	Mute Control		GND
9	Vref	Reference voltage stabilized capacitor connect terminal		V+/2

■ TYPICAL CHARACTERISTICS

Operating Current vs. Operating Voltage
No signal, MUTE=L, Ta=25°C

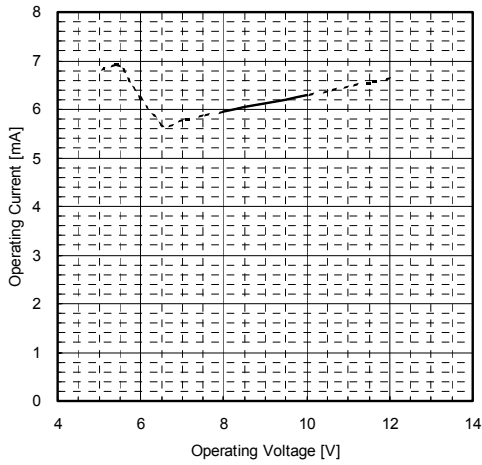

Operating Current vs. Ambient Temperature
V+=9V, No signal, MUTE=L

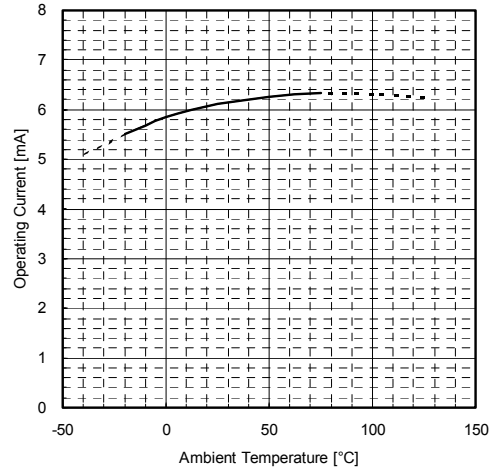

Reference Voltage vs. Operating Voltage
No signal, MUTE=L, Ta=25°C

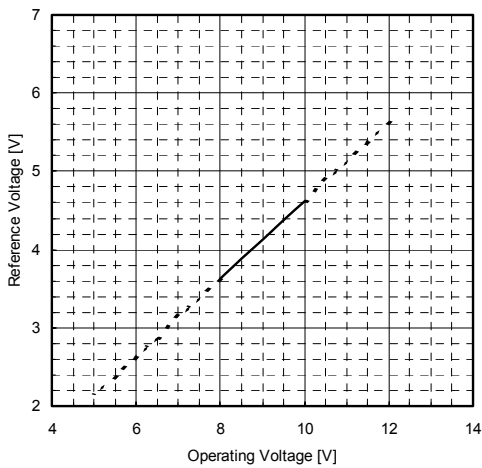

Reference Voltage vs. Ambient Temperature
V+=9V, No signal, MUTE=L

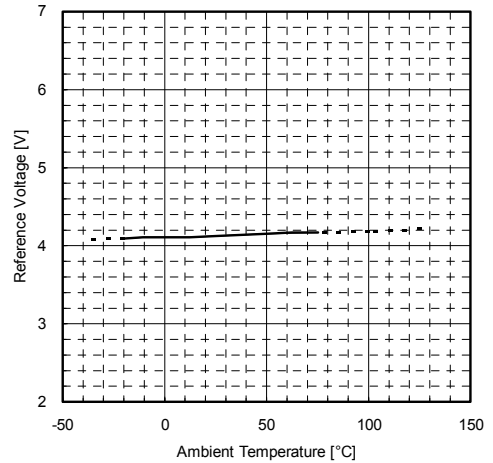

Voltage Gain vs. Control Voltage (Operating Voltage)
Vin=-20dBV, f=1kHz, RL=100Ω, Ta=25°C

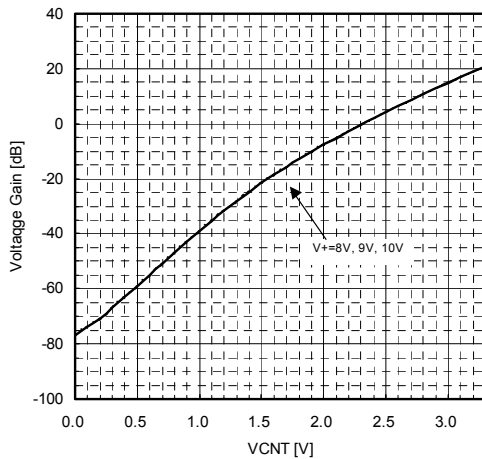

Voltage Gain vs. Control Voltage (Frequency)
V+=9V, Vin=-20dBV, RL=100Ω, Ta=25°C

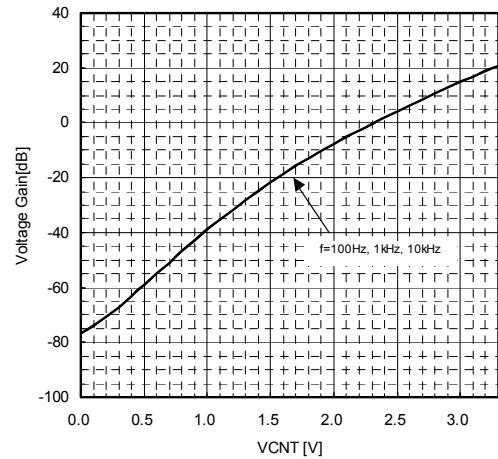

TYPICAL CHARACTERISTICS

Voltage Gain vs. Control Voltage (Ambient Temperature)
 $V_+ = 9V, V_{in} = -20dBV, f = 1kHz, R_L = 100\Omega$

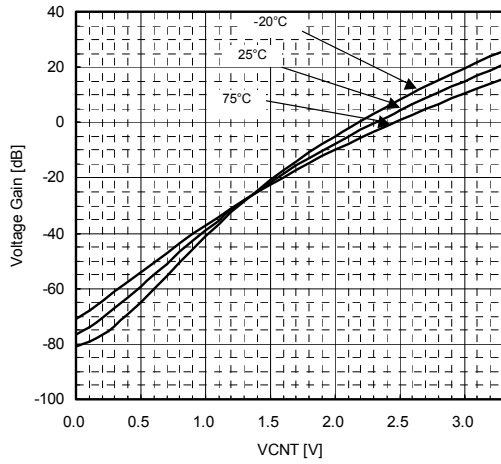

Mute Level vs. Mute Control Voltage
 $V_+ = 9V, V_{in} = 0dBV, f = 1kHz, G_v = 0dB, R_L = 100\Omega$

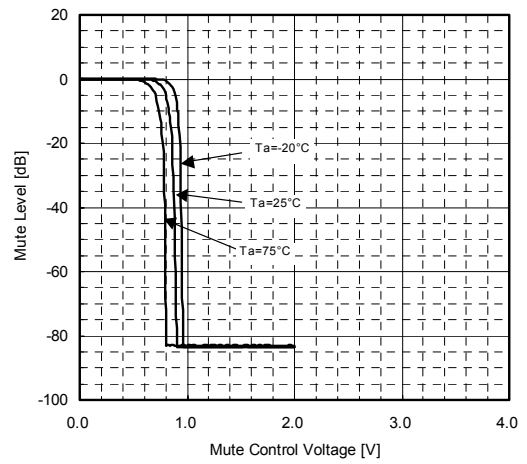

Mute Level vs. Frequency
 $V_+ = 9V, V_{in} = 0dBV, G_v = 0dB, R_L = 100\Omega, MUTE = H, T_a = 25^\circ C$

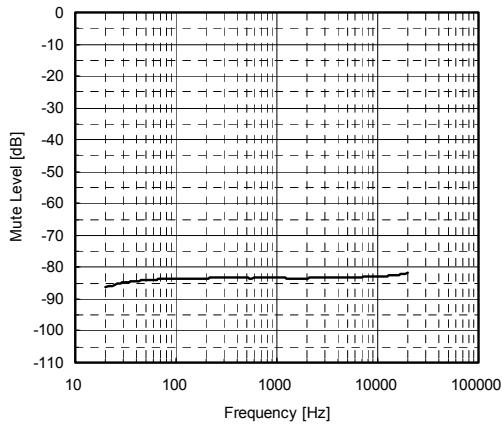

Mute Level vs. Ambient Temperature
 $V_+ = 9V, V_{in} = 0dBV, f = 1kHz, G_v = 0dB, R_L = 100\Omega, MUTE = H$

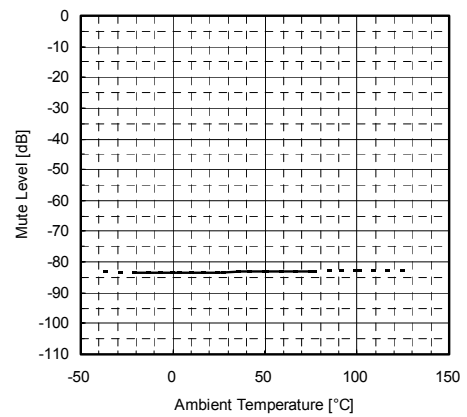

Voltage Gain Channel Balance vs. Control Voltage (Frequency)
 $V_+ = 9V, V_{in} = -20dBV, R_L = 100\Omega, T_a = 25^\circ C$

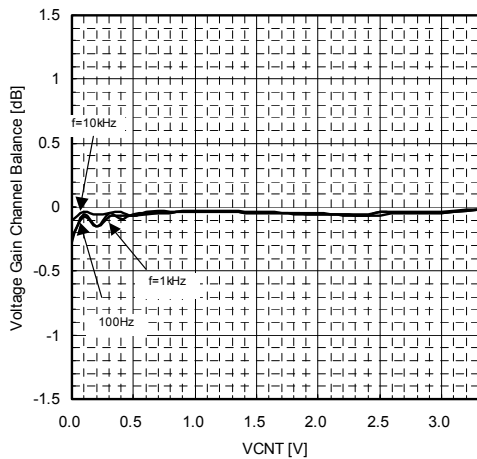

Voltage Gain Channel Balance vs. Control Voltage (Ambient Temperature)
 $V_+ = 9V, V_{in} = -20dBV, f = 1kHz, R_L = 100\Omega$

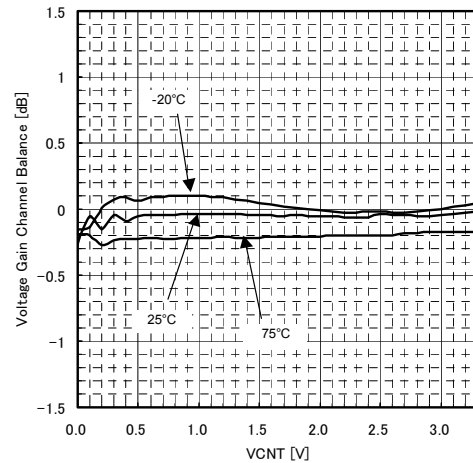

TYPICAL CHARACTERISTICS

THD+N vs. Output Power (Operating Voltage)
 $f=1\text{kHz}$, $G_v=10\text{dB}$, $R_L=100\Omega$, $BW=400\text{Hz}-30\text{kHz}$, $T_a=25^\circ\text{C}$

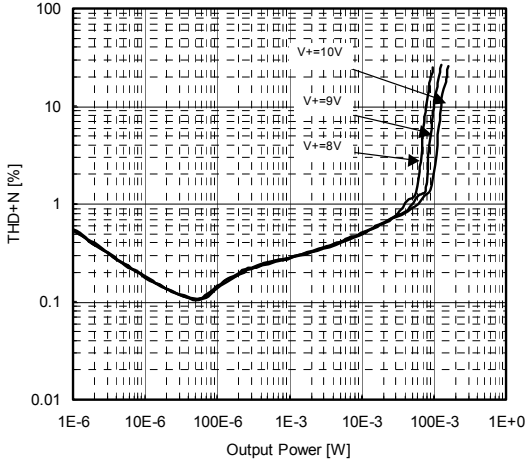

THD+N vs. Output Power (Frequency)
 $V_+=9\text{V}$, $G_v=10\text{dB}$, $R_L=100\Omega$, $T_a=25^\circ\text{C}$

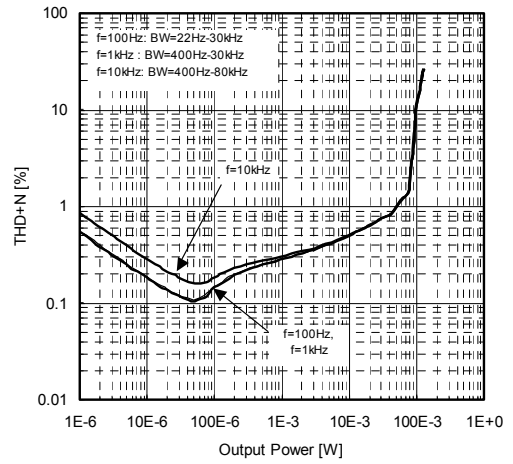

THD+N vs. Output Power (Ambient Temperature)
 $V_+=9\text{V}$, $f=1\text{kHz}$, $G_v=10\text{dB}$, $R_L=100\Omega$, $BW=400\text{Hz}-30\text{kHz}$

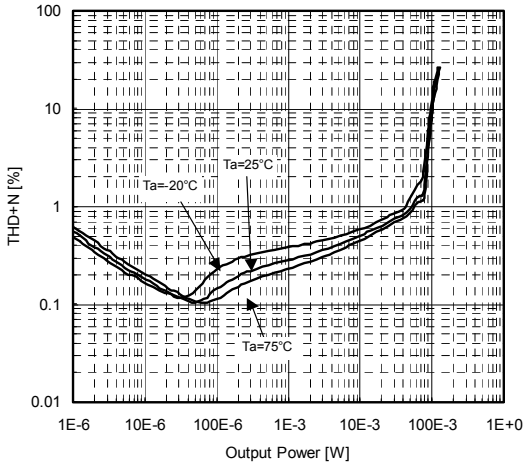

Power Dissipation vs. Output Power
 $f=1\text{kHz}$, $G_v=10\text{dB}$, $R_L=100\Omega$, $BW=400\text{Hz}-30\text{kHz}$, $T_a=25^\circ\text{C}$, 2ch Input

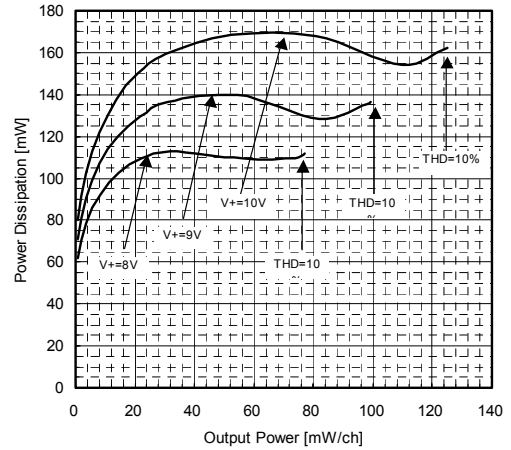

Output Power vs. Operating Voltage
 $f=1\text{kHz}$, $\text{THD}=10\%$, $G_v=10\text{dB}$, $R_L=100\Omega$, $BW=400\text{Hz}-30\text{kHz}$

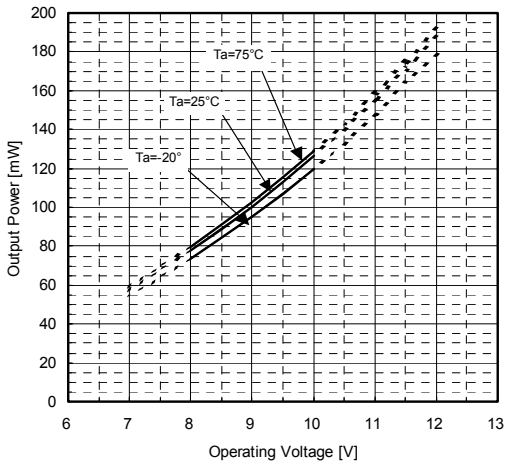

Output Noise Voltage 1 vs. Ambient Temperature
 $V_+=9\text{V}$, $G_v=0\text{dB}$, $R_L=100\Omega$, $R_g=0\Omega$, A-Weighted, MUTE=L

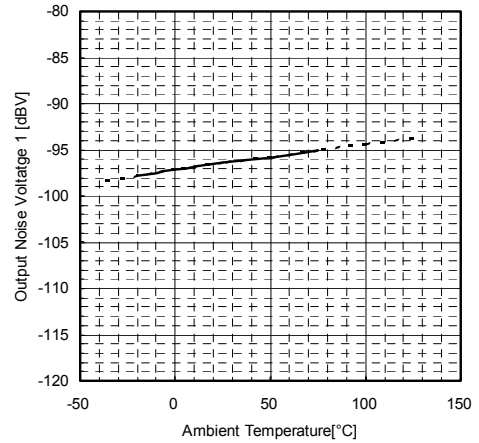

■ TYPICAL CHARACTERISTICS

Output Noise Voltage 2 vs. Ambient Temperature
 V+=9V, RL=100Ω, Rg=0Ω, A-Weighted, MUTE=H

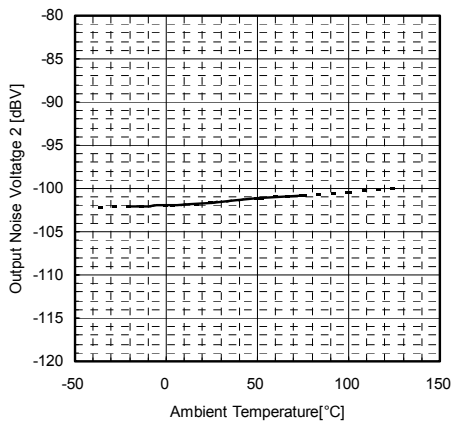

[CAUTION]

The specifications on this data book are only given for information, without any guarantee as regards either mistakes or omissions. The application circuits in this data book are described only to show representative usages of the product and not intended for the guarantee or permission of any right including the industrial rights.

X-ON Electronics

Largest Supplier of Electrical and Electronic Components

Click to view similar products for [Audio Amplifiers](#) category:

Click to view products by [NJR](#) manufacturer:

Other Similar products are found below :

[LV47002P-E](#) [AZ386MTR-E1](#) [NCP2811AFCT1G](#) [NCP2890AFCT2G](#) [NCP2993FCT2G](#) [NJW1194V-TE1](#) [LA4282-E](#) [LA4631VC-XE](#)
[SSM2377ACBZ-R7](#) [TDA7385H](#) [TDA7391LVPDTR](#) [MP7741DQ-LF-P](#) [IS31AP2121-LQLS1](#) [IS31AP4915A-QFLS2-TR](#) [LA74309FA-BH](#)
[480263C](#) [NCP2820FCT2G](#) [STPA001](#) [TDA1591T](#) [TDA7563BH](#) [TDA7718B](#) [LA4425F-E](#) [LA4742-E](#) [TDA7563AH](#) [TDA7850H](#) [STK433-](#)
[070GN-E](#) [SSM2529ACBZ-R7](#) [SSM2518CBZ-R7](#) [MAX9890BEBL+T](#) [MAX98303EWE+T](#) [MAX98358EWL+](#) [MAX98304DEWL+T](#)
[MAX9744ETHT](#) [TS2012EIJT](#) [NCP2809BMUTXG](#) [SSM2375CBZ-REEL7](#) [IS31AP4996-GRLS2-TR](#) [STPA002OD-4WX](#)
[MAX98300EWL+T](#) [MAX9717DETA+T](#) [MAX13336EGEE/V+](#) [MAX9717CETA+T](#) [MAX9724AEBC+TG45](#) [MAX9736DETJ+](#)
[TDA75612LV-48X](#) [TDA75616LV-48X](#) [BD88420GUL-E2](#) [MP7751GF](#) [TDA7850AH](#) [STK433-060NGEVB](#)