

821B YYY - 1 0 3 R 00 1

SERIES 12.00 [0.475]
 # OF POSITIONS (Ex. 002)
 SEE CHART A
 1 = MALE
 SOLDER CUP (PANEL MOUNT)
 1 = GOLD FLASH
 RoHS COMPLIANT
 NICKEL/CHROME PLATED SHELL

CHARACTERISSTICS

MATERIALS

SHELL : BRASS
 SHELL PLATING : NICKEL
 NUT : BRASS
 NUT PLATING : NICKEL
 LATCH SLEEVE : BRASS
 LATCH SLEEVE PLATING : NICKEL
 CONTACTS : COPPER ALLOY
 CONTACT PLATING : 7µ" GOLD PLATED OVER 196µ" NICKEL MIN.
 INSULATOR : PPS (HIGH TEMPERATURE)

MECHANICAL

DURABILITY: 5000 CYCLES
 OPERATING TEMP. RANGE: -40° C ~ +200° C
 PROCESS TEMPERATURE : 260°C FOR 5 SECONDS
 MAX. TORQUE VALUE : 4.5 Nm [39 IN/lbs]
 SHIELDING: 75dB @ 10MHz
 40dB @ 1GHz

IP RATING: 50

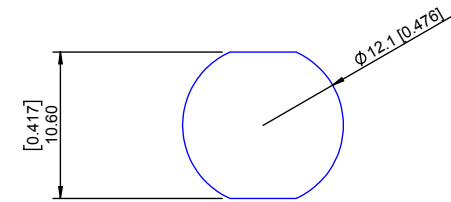
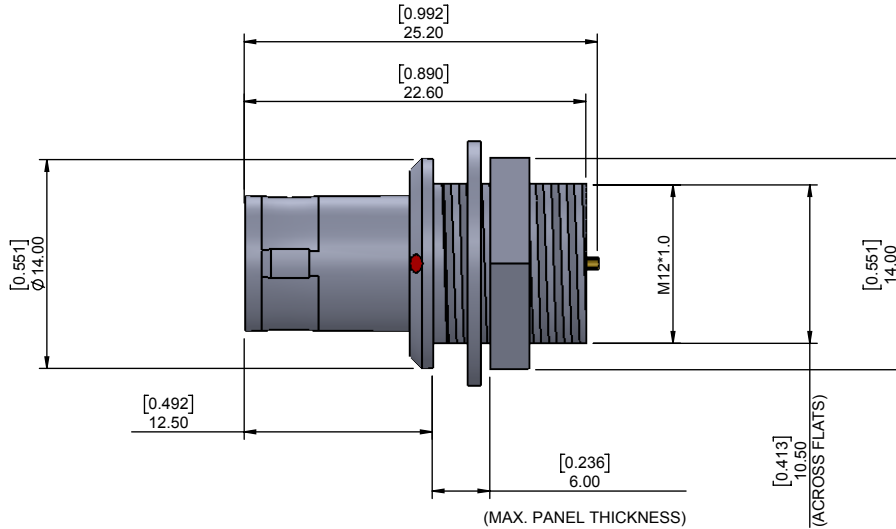

PANEL CUTOUT
 TOLERANCE = +0.10, -0.0
 [+0.004, -0.00]

CHART A

● = KEY LOCATION

VIEW FROM TERMINATION END

2 POSITION 20 AWG MAX. 15 AMP MAX. PIN Ø = 1.30 [0.051]	3 POSITION 20 AWG MAX. 12 AMP MAX. PIN Ø = 1.30 [0.051]	4 POSITION 22 AWG MAX. 10 AMP MAX. PIN Ø = 0.90 [0.035]	5 POSITION 22 AWG MAX. 9 AMP MAX. PIN Ø = 0.90 [0.035]	6 POSITION 24 AWG MAX. 7 AMP MAX. PIN Ø = 0.70 [0.028]	7 POSITION 24 AWG MAX. 7 AMP MAX. PIN Ø = 0.70 [0.028]	8 POSITION 24 AWG MAX. 5 AMP MAX. PIN Ø = 0.70 [0.028]	10 POSITION 28 AWG MAX. 2.5 AMP MAX. PIN Ø = 0.50 [0.020]	14 POSITION 28 AWG MAX. 2 AMP MAX. PIN Ø = 0.50 [0.020]
CONTACT RESISTANCE = 5 mΩ TEST VOLTAGE = 1500V WORKING VOLTAGE = 500V	CONTACT RESISTANCE = 5 mΩ TEST VOLTAGE = 1300V WORKING VOLTAGE = 430V	CONTACT RESISTANCE = 6 mΩ TEST VOLTAGE = 1300V WORKING VOLTAGE = 430V	CONTACT RESISTANCE = 6 mΩ TEST VOLTAGE = 1250V WORKING VOLTAGE = 415V	CONTACT RESISTANCE = 7.5 mΩ TEST VOLTAGE = 1050V WORKING VOLTAGE = 350V	CONTACT RESISTANCE = 7.5 mΩ TEST VOLTAGE = 950V WORKING VOLTAGE = 315V	CONTACT RESISTANCE = 7.5 mΩ TEST VOLTAGE = 950V WORKING VOLTAGE = 315V	CONTACT RESISTANCE = 10 mΩ TEST VOLTAGE = 900V WORKING VOLTAGE = 300V	CONTACT RESISTANCE = 10 mΩ TEST VOLTAGE = 800V WORKING VOLTAGE = 260V

RoHS COMPLIANT



THESE DRAWINGS AND SPECIFICATIONS ARE THE PROPERTY OF NorComp AND SHALL NOT BE REPRODUCED, COPIED OR USED AS THE BASIS FOR THE MANUFACTURE OR SALE OF APPARATUS WITHOUT WRITTEN PERMISSION.

NorComp

DRAWN: M. SIGMON	DATE: 02-05-16	SCALE: N.T.S.	SHEET 1 OF 1	REV: 3
DWG NO. 821BYYY-103R001				

X-ON Electronics

Largest Supplier of Electrical and Electronic Components

Click to view similar products for [Circular Push Pull Connectors](#) category:

Click to view products by [NorComp](#) manufacturer:

Other Similar products are found below :

[6407-249V-11273P](#) [6408-201V-13273](#) [6408-202V-13343](#) [6408-202V-17343](#) [EZG.0B.309.CLN](#) [FFA.2S.310.ZLA](#) [FGJ.1B.304.CLLD76](#)
[FGJ.1B.306.CWLD72](#) [FGJ.3B.304.CYMD10Z](#) [FGJ.3B.304.CYMD82Z](#) [FHG.1B.303.CYCZ](#) [PCS.01.250.DLLE24](#) [PHG.0K.305.CYMC40Z](#)
[PHG.1K.308.CLLK85](#) [PKG.M0.6BL.LZ](#) [PLC.M1.0SL.LA](#) [GMA.10.290.DN](#) [GMA.3B.090.DA](#) [PRG.M0.6GL.LC52GZ](#) [PSA.1S.275.CTLC66](#)
[ABF.1S.250.NTA](#) [133020F](#) [1331ER193MZ](#) [1332M107MZ](#) [DTS26Z19-32JA-LC](#) [DTS26Z19-32SA](#) [DTS26Z19-32SA-LC](#) [EAJ.1B.306.CWA](#)
[ECG.XB.312.CLL](#) [1589430-2](#) [EEA.0B.305.CLN](#) [EEA.0B.309.CLL](#) [ELF.00.250.NTL](#) [ERA.01.250.DLL](#) [BRR.2S.200.PZVG](#) [HR10A-P](#)
[CAH.M34.SLL.C72GZ](#) [CAJ.M34.SLL.C72GZ](#) [300500](#) [ESB.00.303.NLL](#) [EXG.0B.309.HLN](#) [FFB.1S.250.CLAC27](#) [FGA.2B.306.CYCD92](#)
[FGA.2B.306.CYCD92Z](#) [FGJ.1B.302.CYMD62](#) [FGJ.3B.308.CLLD72Z](#) [FHG.1B.303.CYCD62](#) [FLC.00.250.CTAC31](#) [PCS.01.250.DLLE31](#)
[PKA.M1.0TL.LG](#)