

TFT LCD Module with MPCT (Metallised Projective Capacitive Touch)

Hardware Specification

Model: GT800X480A-C903P

Specification No:	DS-1940-0001-04	
Date of Issue:	January 29, 2016	(00)
Revision:	February 19, 2016	(01)
	March 18 2016	(02)
	June 13 2016	(03)
	July 21 2016	(04)

Published by
NORITAKE ITRON Corp. / Japan
<http://www.noritake-itron.jp>

This specification is subject to change without prior notice.

This product complies with RoHS Directive
Please contact our sales consultant for details and to confirm the current status

Contents

1	General Description	2
1.1	Scope.....	2
1.2	Construction	2
1.3	Outline	2
1.4	Block Diagram	2
2	General Purpose I/O Port.....	3
3	Electrical Specifications	3
3.1	Absolute Maximum Ratings.....	3
3.2	Electrical Ratings.....	3
3.3	Electrical Characteristics	4
4	Environmental Specifications	5
5	Optical Specifications (at 25°C)	5
6	Physical Specifications.....	5
7	Applicable Specifications	5
8	Interface Details.....	6
8.1	USB Interface (CN3).....	6
8.1.1	USB Interface – Summary	6
8.1.2	USB Interface – Technical Details	6
8.1.3	USB Interface – Power	6
8.2	Serial Interface (CN9).....	7
8.2.1	UART Mode (J5 = SHORT, J6 = SHORT)	7
8.2.2	SPI Mode (J5 = OPEN, J6 = OPEN)	8
8.2.3	I ² C Mode (J5 = SHORT, J6 = OPEN)	9
8.3	Transmit data interface.....	11
8.4	Reset	11
9	Touch Panel.....	12
9.1	Outline	12
9.2	Basic Operation	12
9.3	Coordinates Correction (calibration).....	13
9.3.1	Correction Procedure.....	13
9.4	Warnings.....	14
10	Setup.....	14
10.1	Jumper.....	14
11	Connectors.....	15
11.1	Serial Interface & Power through-holes (CN9).....	15
11.2	General Purpose I/O Port through-holes & Power through-holes (CN11).....	15
11.3	Extension General Purpose I/O Port through-holes & Power through-holes (CN10)	15
11.4	USB Interface (CN3).....	15
11.5	Power through-holes (CN8).....	15
11.6	Connector Position	16
12	Physical Dimensions.....	17
	Notice for the Cautious Handling of LCD Modules	18
	Revision history.....	19

1 General Description

1.1 Scope

This specification covers the hardware aspects of the GT800X480A-C903P TFT-LCD graphic display module with a projected-capacitive touch panel.

1.2 Construction

The module consists of a 800 × 480 × RGB color graphic TFT-LCD with touch panel, refresh RAM, character generator, DC/DC converter, Microcontroller, and all necessary control logic. The module can simultaneously display graphic patterns, images, and text characters on the screen.

1.3 Outline

Display: 800×480 pixels, 65K colors (16-bit color (RGB 5-5-5 + 1bit Intensity))
 Power supply: Single 5 V_{DC}
 Serial interface (UART / I²C / SPI CMOS 3 / 3.3V)
 USB interface (High-speed / Full-speed)
 I/O port: 26 bits General-purpose I/O port
 Function: Character display
 Graphic display
 Control command
 Display action command
 Window function
 General-purpose I/O port control
 Macro, Program Macro function
 Character and Image download function
 Memory SW, Data storage
 Touch panel input

Related specifications:

DS-1940-0003-xx: "General Function" Software Specification.

DS-1940-0005-xx: "Program Macro" Software Specification.

1.4 Block Diagram

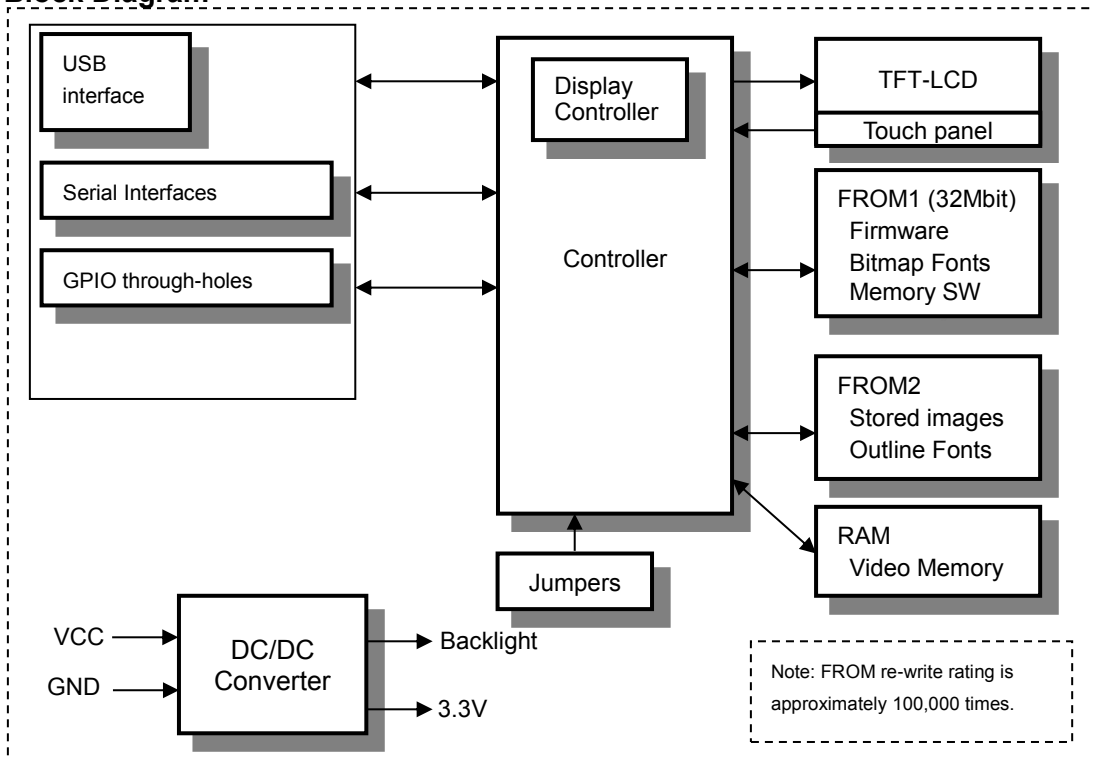

2 General Purpose I/O Port

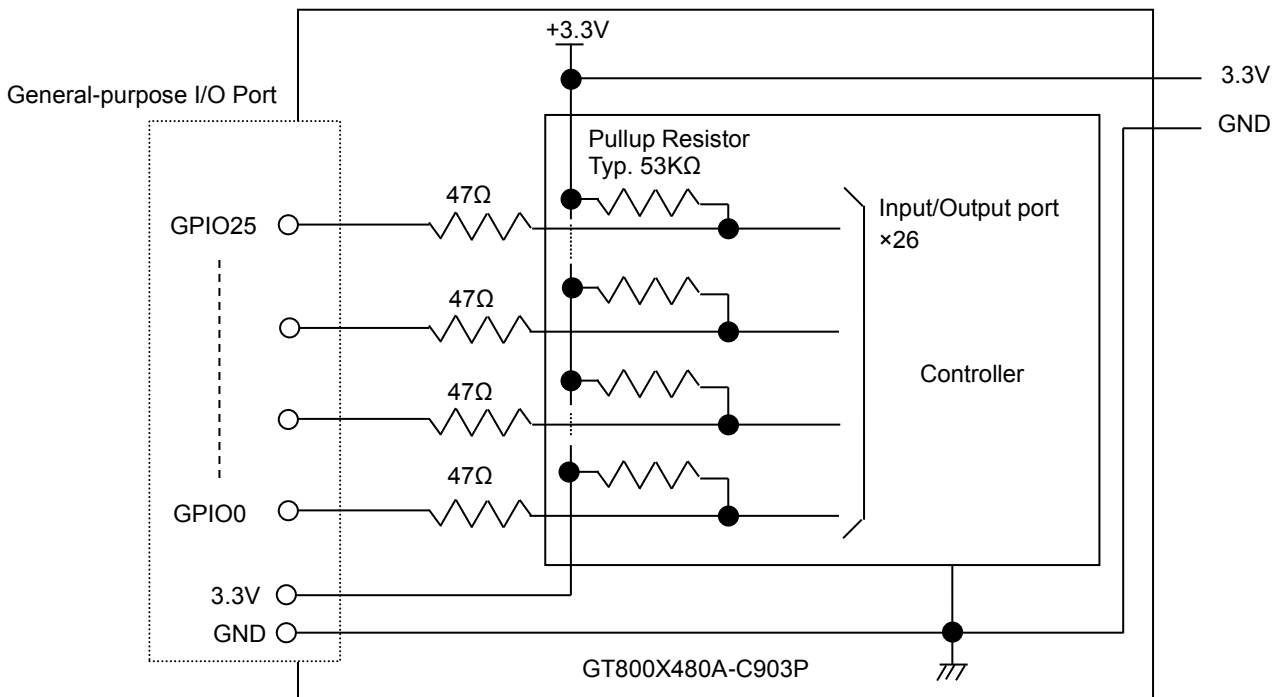

Refer to 3.3 Electrical Characteristics, “General Purpose I/O Port Voltage”.

For controlling, refer to “General Function” Software Specification, “I/O Port Input / Output Setting”, “I/O Port Output”, and “I/O Port Input”.

3 Electrical Specifications

3.1 Absolute Maximum Ratings

Power Supply Voltage

Parameter	Symbol	Min.	Typ.	Max.	Unit	Note
Power Supply Voltage	VCC	-0.3	-	+6.0	VDC	

Logic Voltage

Parameter	Symbol	Min.	Typ.	Max.	Unit	Note
UART RXD, DSR	VsIN1	-0.3	-	3.6	VDC	
I ² C I/F SCL, SDA,*RESET	VsIN2	-0.3	-	3.6	VDC	
SPI SCK, MOSI, SSEL, *RESET	VsIN3	-0.3	-	3.6	VDC	

I/O Port Voltage

Parameter	Symbol	Min.	Typ.	Max.	Unit	Note
I/O port Port 0, Port 1 Port 2, Port3	ViIN	-0.3	-	3.3+0.3	VDC	

3.2 Electrical Ratings

Parameter	Symbol	Min.	Typ.	Max.	Unit	Note
Power supply voltage	VCC	4.75	5.0	5.25	VDC	

All driving voltage for the TFT-LCD is generated from the on-board DC/DC converter.

3.3 Electrical Characteristics

Logic Input/Output Condition

Measuring Conditions: Ambient temperature = 25 °C, VCC=5.0VDC

Parameter		Symbol	Min.	Typ.	Max.	Unit	Condition	Note
UART	Logic input voltage RXD, DSR, *Reset	VsIH1	2.7	-	3.5	VDC	-	-
		VsIL1	0	-	0.6	VDC	-	-
	Logic output voltage TXD, DTR	VsOH1	2.8	-	-	VDC	RL=3kΩ	-
		VsOL1	0	-	0.4	VDC		-
I ² C I/F	Logic input voltage SCL, SDA, *RESET	VsIH2	2.7	-	3.5	VDC	-	-
		VsIL2	0	-	0.6	VDC	-	-
	Logic output voltage TRDY, SBUSY	VsOH2	2.8	-	-	VDC	-	-
		VsOL2	0	-	0.4	VDC	-	-
Internal pull-up resistance SDA,SCL		Rp		10		kΩ	-	-
SPI	Logic input voltage SCK, MOSI, *RESET,SSEL	VsIH3	2.7	-	3.5	VDC	-	-
		VsIL3	0	-	0.6	VDC	-	-
	Logic output voltage TRDY, SBUSY, MISO	VsOH3	2.8	-	-	VDC	-	-
		VsOL3	0	-	0.4		-	-

General Purpose I/O Port Voltage

Measuring Conditions: Ambient temperature = 25 °C, VCC=5.0VDC

Parameter		Symbol	Min.	Typ.	Max.	Unit	Condition	Note
General-purpose I/O port	Logic input current Port 0,1,2,3	IiIH	-	-	1.0	μADC	-	-
		IiIL	-	-	-200	μADC	-	-
	Logic input voltage Port 0,1,2,3	ViIH	2.4	-	3.3	VDC	-	-
		ViIL	0	-	0.8	VDC	-	-
	Logic output voltage Port 0,1,2,3	ViOH	2.8	-	-	VDC	IOH=-200μA	-
		ViOL	-	-	0.4	VDC	IOL=1.6mA	-

General Purpose I/O Port Output Permissible Current

Measuring Conditions: Ambient temperature = 25 °C, VCC=5.0VDC

Parameter		Symbol	Min.	Typ.	Max.	Unit	Condition	Note
General-purpose I/O port	Output permissible current Port 0,1,2,3 (Single port)	IiOHp	0	-	-5	mADC	-	-
		IiOLp	0	-	5	mADC	-	-
	Output permissible current Port 0,1,2,3 (Sum of all port)	IiOht	0	-	-80	mADC		
		IiOLt	0	-	80	mADC		

Output current should exceed the above values.

If driving LEDs or other devices directly, insert current limiter into the output line.

Power Supply Condition

Measuring Conditions: Ambient temperature = 25 °C, VCC=5.0VDC

Parameter		Symbol	Min.	Typ.	Max.	Unit	Condition	Note
Power Supply current		ICC1	-	0.7	0.9	ADC	Display power ON 100% Brightness	-
Power Supply current		ICC2	-	0.3	0.45	ADC	Display power OFF	-
Power Consumption			-	3.5	4.5	W	Display power ON 100% Brightness	-

Note:

The rise time of supply voltage should not exceed 100ms.

Inrush current at power-on may exceed twice normal current.

Display power OFF: Refer to “General Function” Software Specification, “Display power ON/OFF” command.

4 Environmental Specifications

Operating temperature: -20 to +70 °C

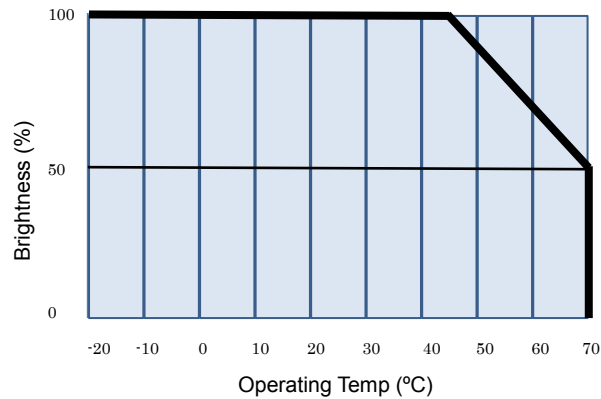

Storage temperature: -30 to +80 °C

Operating humidity: 20 to 80 % R.H (Non-condensing) (Temp. ≤ +60 °C)
45 % R.H (Non-condensing) (Temp. > +60 °C)

Storage humidity: 20 to 80 % R.H (Non-condensing) (Temp. ≤ +60 °C)
45 % R.H (Non-condensing) (Temp. > +60 °C)

Vibration (non-operating): 10-55-10Hz, all amplitude 1mm, 30 minutes, X-Y-Z

Shock (non-operating): 392m/s² (40G) 9ms X-Y-Z, 3 times each direction

5 Optical Specifications (at 25°C)

LCD Type: TFT, Negative, Transmission

Brightness TFT with touch panel: Min. 240 cd/ m² (nit), Typ. 400 cd/ m² (nit)
(White screen at the center of display, 100% Brightness)

Color: RGB

View Direction: 12 o'clock

Gray Scale Inversion Direction: 6 o'clock

6 Physical Specifications

Number of pixels: 800 × RGB × 480

Display area: 152.4mm × 91.44mm (X × Y)

Pixel pitch: 0.19mm × 0.19mm (X × Y)

Weight: Approximately 275g

7 Applicable Specifications

Applicable reliability specification: TT-99-3102x

Applicable production specification: TT-98-3413x

8 Interface Details

USB, UART, I²C, and SPI serial interfaces are included on this module. The module will accept data from any configured interface. Response data is generally transmitted via the USB interface if it is active or via the configured serial interface otherwise (refer to 8.3 Transmit data interface).

8.1 USB Interface (CN3)

8.1.1 USB Interface – Summary

The USB interface is USB 2.0 High-speed (480Mbps) / Full-speed (12 Mbps) capable. Typically, the supplied USB driver is used, and the display module is accessed via a “Virtual COM port” (refer to **USB VCOM Driver Installation Manual DS-1972-0000-xx**). The display module can also be used as a *WinUSB* device, using the standard *WinUSB* driver. Alternatively, refer to USB Interface – Technical Details (below) if using the USB interface with a custom driver or embedded system, etc. Refer to the [USB 2.0 Specification](#) for further details.

8.1.2 USB Interface – Technical Details

The device has a single configuration, with a single interface, supporting two endpoints for data transfer:

Endpoint	Type	Maximum packet size
Endpoint 0	Control	64 bytes
Endpoint 1	Bulk IN	Full speed: 64 bytes, High speed: 512 bytes
Endpoint 2	Bulk OUT	Full speed: 64 bytes, High speed: 512 bytes

Vendor ID: 0EDA (hex)

Product ID: 1200 (hex)

Device Class and Interface Class: FF (hex) (vendor-specific)

USB Serial Number: Firmware F1.00 onwards: Unique serial number

Prior firmware: Not supported

WinUSB compatibility:

Firmware versions F1.00 onwards support *Microsoft OS String Descriptors*, which enable automatic recognition of *WinUSB* compatibility for applicable operating systems (manual configuration, using an .inf file, is also possible). The Device Interface GUID reported by the device is {6120D798-D192-4463-B0DE-2B65ED2F4870}. This GUID is used by applications on the host in order to access the device.

8.1.3 USB Interface – Power

The power supply current-draw during normal operation (900mA maximum – refer to 3.3 Electrical Characteristics) is more than the maximum 500mA available from a USB port, as provided by the USB specification. This means that USB “bus-powered” operation from a standard USB port cannot be guaranteed so power must be provided separately by a 5-volt power supply of adequate capacity.

However, for an embedded system, or custom USB host/hub, etc, if it can be determined that sufficient current can be supplied, the TFT module can be powered via the USB connector (CN3) by shorting the through-hole jumper JP1. If using a separate power supply, leave JP1 open so that voltage is not applied towards the USB host.

In all cases, in the USB configuration descriptor, the power requirements are reported to the host as “bus-powered” 100mA. This helps to ensure USB connectivity can be established if connected to a “low-power port” (for example, the downstream port of a bus-powered hub).

8.2 Serial Interface (CN9)

One of three modes is selected by Jumpers J5 and J6. For all modes, the SBUSY/ DTR signal reflects the state of the receive buffer. This can be used for flow control if necessary. Data received is stored in the internal receive buffer, and processed in order of receipt. The TRDY signal indicates whether or not there is data currently held in the transmit buffer.

Buffer Capacity

Receive buffer	2,047 bytes
Transmit buffer	127 bytes

SBUSY / DTR Signal Change Timing

SBUSY change	'L'(READY)→'H'(BUSY)	'H'(BUSY) →'L'(READY)
Receive buffer space	62 bytes or less	128 bytes or more

TRDY signal change timing

TRDY	READY('H')	EMPTY('L')
Condition	Data in transmit buffer	No data in transmit buffer

8.2.1 UART Mode (J5 = SHORT, J6 = SHORT)

Interface Conditions:

Baud rate	4800 to 115200bps (set by Jumper and Memory SW) Default setting: 38400bps
Parity	None, Even, Odd (set by Memory SW) Default setting: None
Format	Start (1 bit) + Data (8 bit) + Parity (0 or 1 bit) + Stop (1 bit)
Communication control signal	DSR, DTR, /TRDY

- Data transmitted from the display is placed in the internal transmit buffer and sent, in order, when DSR = READY.

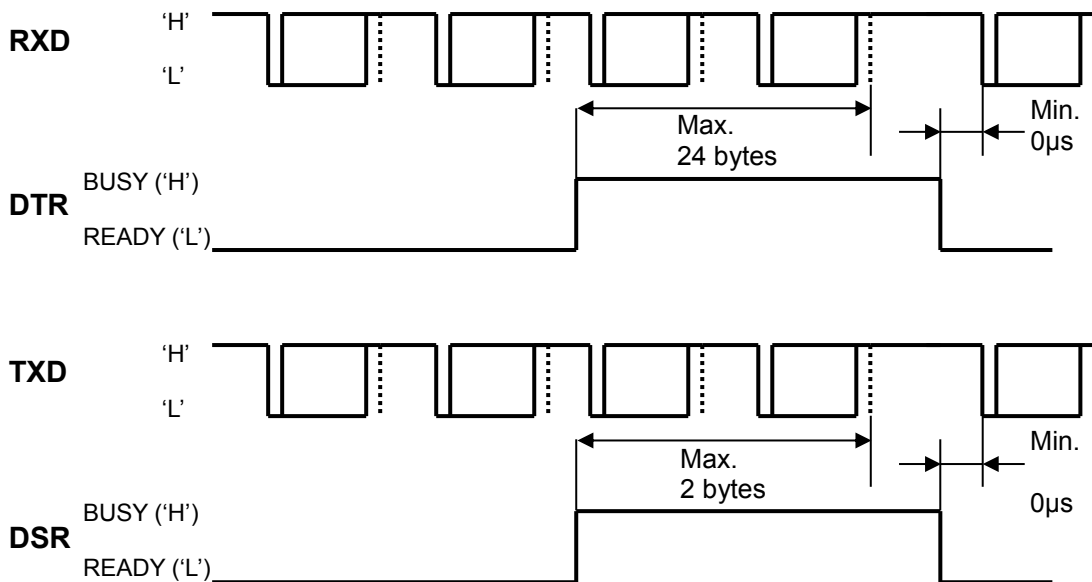

8.2.2 SPI Mode (J5 = OPEN, J6 = OPEN)

Display module operates as an SPI slave; data is sent and received in response to host (master) operations.

SSEL= 1 → 0 → 1 is one command sequence.

1st BYTE	Operation Mode
44h	Data Write (Host → Module)
54h	Data Read (Host ← Module)
58h	Status Read (Host ← Module)

Data Write

When 44h is input as the first byte, the module receives the 2nd and subsequent bytes as data.

	1st BYTE	2nd BYTE	3rd BYTE	---	n BYTE
MOSI	44h	Data(1)	Data(2)	---	Data(n-1)
MISO	-	-	-	---	-

Data Read

When 54h is input as the first byte, the module outputs valid data on the 3rd and subsequent bytes.

The host must read the number of bytes reported by the immediately preceding Status Read command. **The number of bytes reported by the Status read command will be transmitted, with any unread bytes discarded.**

	1st BYTE	2nd BYTE	3rd BYTE	---	n BYTE
MOSI	54h	-	-	---	-
MISO	-	00h	Data(1)	---	Data(n-2)

Status Read

When 58h is input as the first byte, the module outputs status data. **For the 3rd and any subsequent bytes, the most recent status data is provided.**

	1st BYTE	2nd BYTE	---	n BYTE
MOSI	58h	-	---	-
MISO	-	Status	Status	Status

Status bit assignment

b7	b6	b5	b4	b3	b2	b1	b0
SBUSY	0*	TL(b5)	TL(b4)	TL(b3)	TL(b2)	TL(b1)	TL(b0)

SBUSY : SBUSY signal

TL : Number of Transmit data bytes available (maximum 63 bytes)

*: If b6 is 1, the Status byte is invalid.

SPI Timing

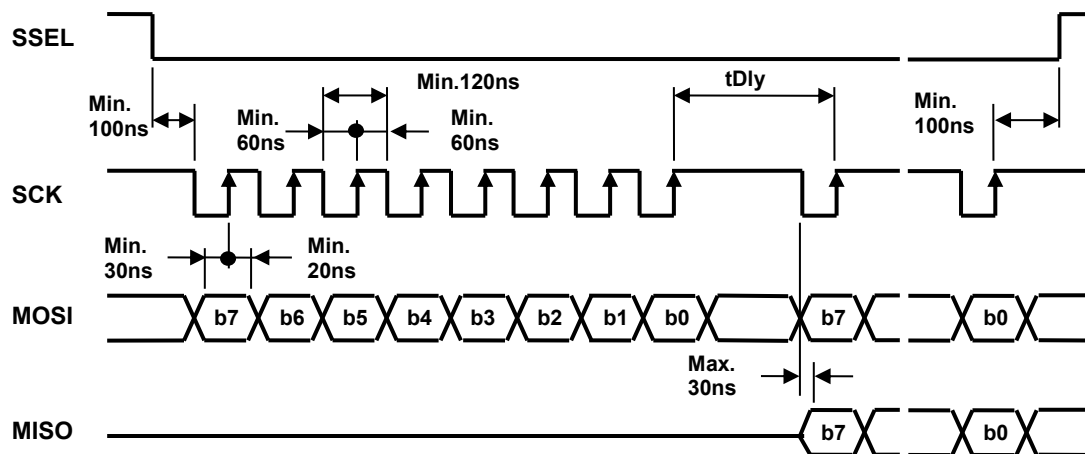

tDly: Data write Min. 120ns
Data Read/Status Read Min. 40µs

8.2.3 I²C Mode (J5 = SHORT, J6 = OPEN)

Slave address is set by Jumpers J0 and J1.

J0	J1	Function
OPEN	OPEN	I ² C Slave Address = 50h
SHORT	OPEN	I ² C Slave Address = 51h
OPEN	SHORT	I ² C Slave Address = 52h
SHORT	SHORT	I ² C Slave Address = 53h

Note: Module does not respond to the General call address (00h).

Communication Parameters

Baud rate	Max. 400kbps
Format	I ² C
Slave address	Set by J0 and J1 (Default setting: 50h)
Supported functions	ACK response, Clock stretch
Communication control signals	SBUSY, TRDY

*Note: If clock stretch is applied during processing of a command, the host (master) will not be able to send or receive any more data until command processing has finished.

If TRDY = EMPTY, FFh is transmitted from the module in response to a read sequence. In addition to the Clock stretch function, flow can also be controlled by monitoring the MBUSY signal. MBUSY signal changes according to the receive buffer state. The host should send data when MBUSY=READY (refer to 8.2 Serial Interface (CN9)).

Data write sequence

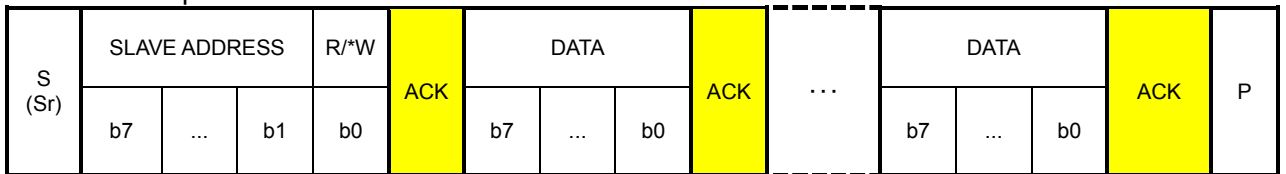

Data read sequence

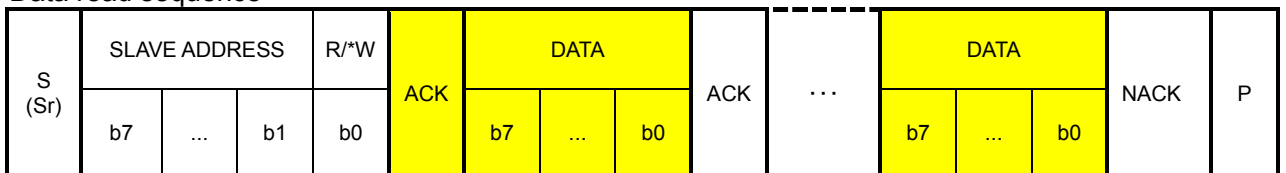

Host (master) is transmitter, display module (slave) is receiver

Host (master) is receiver, display module (slave) is transmitter

I²C Timing

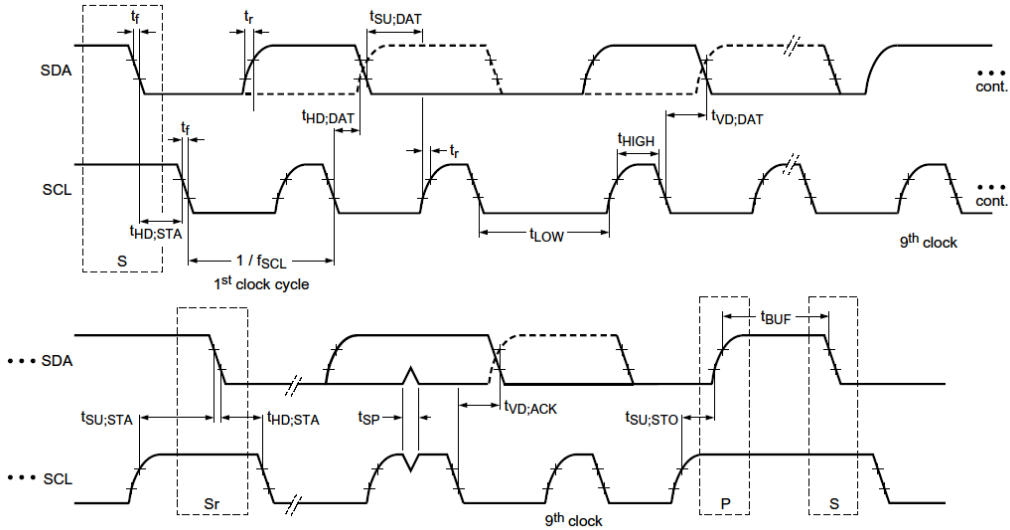

Parameter	Symbol	Condition	Min.	Typ.	Max.	Unit
SCL clock frequency	f_{SCL}	-	0	-	400	kHz
Start condition hold time	$t_{HD:STA}$	-	0.6	-	-	μs
SCL 'L' time	t_{LOW}	-	1.3	-	-	μs
SCL 'H' time	t_{HIGH}	-	0.6	-	-	μs
Start condition setup time	$t_{SU:STA}$	-	0.6	-	-	μs
Data hold time	$t_{HD:DAT}$	-	0	-	-	μs
Data setup time	$t_{SU:DAT}$	-	100	-	-	ns
SCL, SDA rise time	t_r	-	20	-	300	ns
SCL, SDA fall time	t_f	-	-	-	300	ns
Stop condition setup time	$t_{SU:STO}$	-	0.6	-	-	μs
Stop condition – start condition bus idle time	t_{BUF}	-	20	-	-	μs

Data Write Sequence

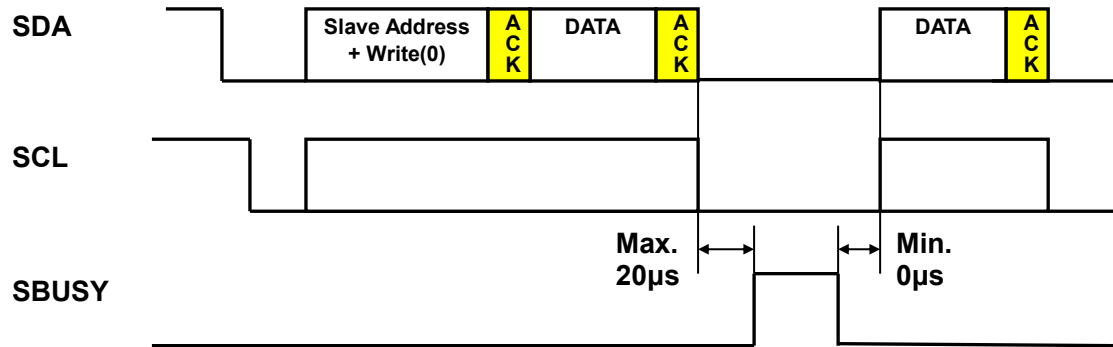

Data Read Sequence

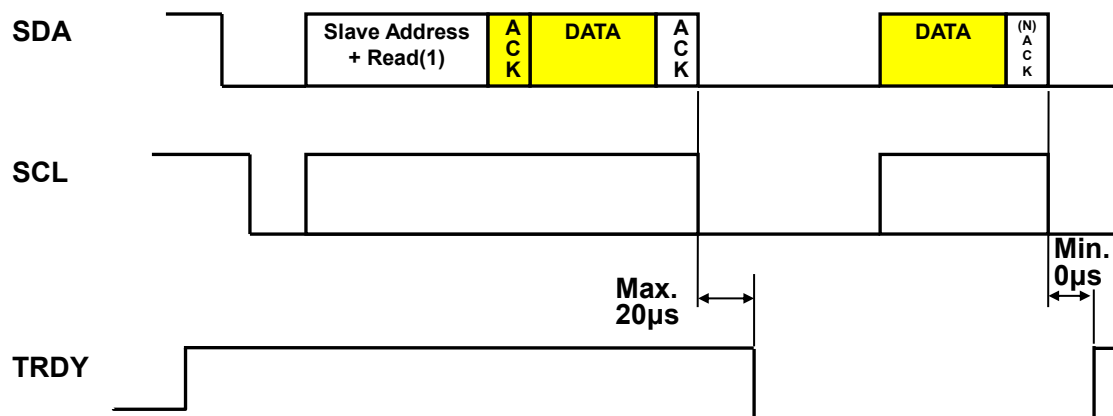

8.3 Transmit data interface

If the USB interface is used in addition to a Serial interface, confusion can arise over which interface data transmitted from the display module is sent via.

Initially, the configured Serial interface is selected for transmit data.

If the USB interface is active and a USB read is attempted by the host (ie, a USB bulk-IN transaction is directed at the device's Endpoint 1), the USB interface is selected for transmit data.

However, if data is subsequently received on the configured Serial port, the configured Serial port is then used instead, from that point onwards, for all transmit data (regardless of USB activity). This state continues until an external reset, power cycle, or "User setup mode end" command.

8.4 Reset

Display module can be reset by inputting a LO signal to *RESET (connector CN9, pin 1).

Note that, while *RESET is held LO, and for up to 200ms after *RESET release (including initial power-on time), pin 2 of connector CN9 (I²C signal SCL / SPI signal SCK) is held LO. To avoid overcurrent due to signal contention, ensure that any line connected to this pin is not driven HI during this time.

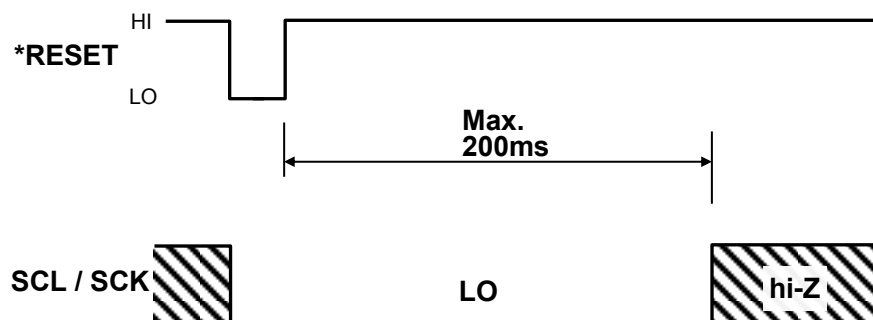

9 Touch Panel

9.1 Outline

Detection method: MPCT (Metallised Projective Capacitive Touch) supporting multi-touch.

9.2 Basic Operation

The display module features a touch panel for handling input by fingertip or touch pen, etc. The touch panel function sends data for the input position or operation of user-defined switch buttons.

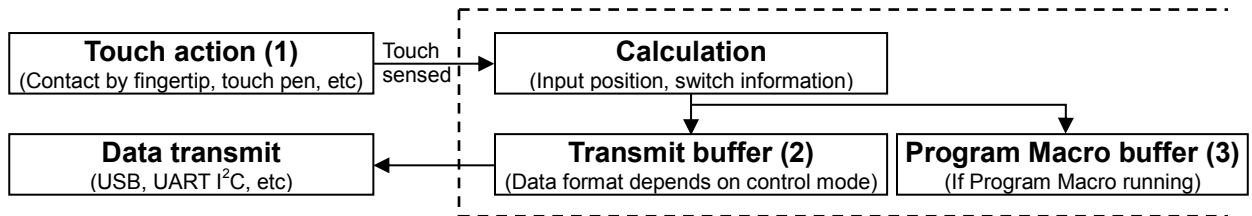

Refer to “General Function” Software Specification for details.

9.3 Coordinates Correction (calibration)

The display module includes a touch position correction function, for minimizing any inconsistency between the actual touch position and the internally-calculated position information.

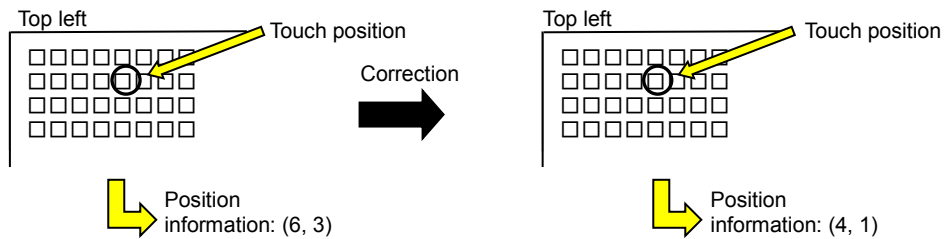

The correction function requires a touch on a single-dot position 5 times with a small finger point. Note: The display module is shipped from the factory in a correctly-adjusted state.

9.3.1 Correction Procedure

1. Short jumper J10 and power ON. The screen shown on the right is displayed. (For jumper details, refer to 10.1 Jumper.)

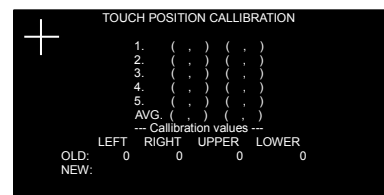

2. Touch the center of the upper left cross 5 times.

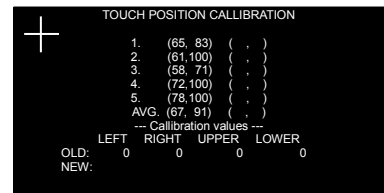

3. Touch the center of the bottom-right cross 5 times.

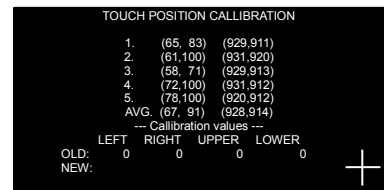

4. To commit the calculated calibration values, press and hold "YES". To discard the values, press "NO".

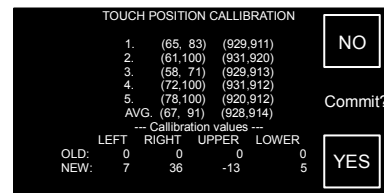

5. The module will restart. Confirm touch operation with J10 open.

9.4 Warnings

Because this touch panel is capacitive type, touch won't work if a conductive material is placed on the touch area or bezel area. We recommend the use of non-conductive material like an acrylic panel. An example is shown below.

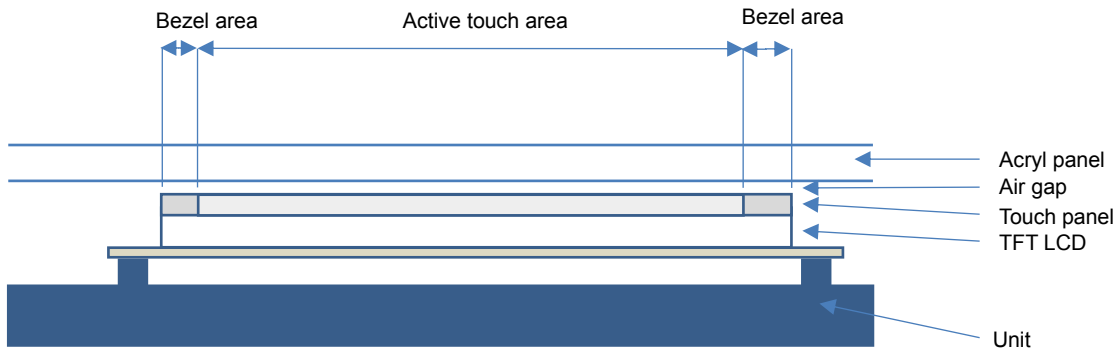

When installing, be careful not to pinch the backlight power cable near the lower left corner, or the FPC cables on the lower edge (refer to 12 Physical Dimensions).

10 Setup

10.1 Jumper

Jumper	Function	Default
J0	I ² C Slave Address	Open
J1		Open
J2	Reserved	Open
J3	Baud Rate	Open
J4		Open
J5	Serial Interface (CN9) mode	Open
J6		Open
J7	Macro Start	Open
J8	Reserved	Open
J9	Reserved	Open
J10	Touch panel calibration mode	Open

Open = "H", Short = "L"

Refer to Software Specification for Jumper setting details.

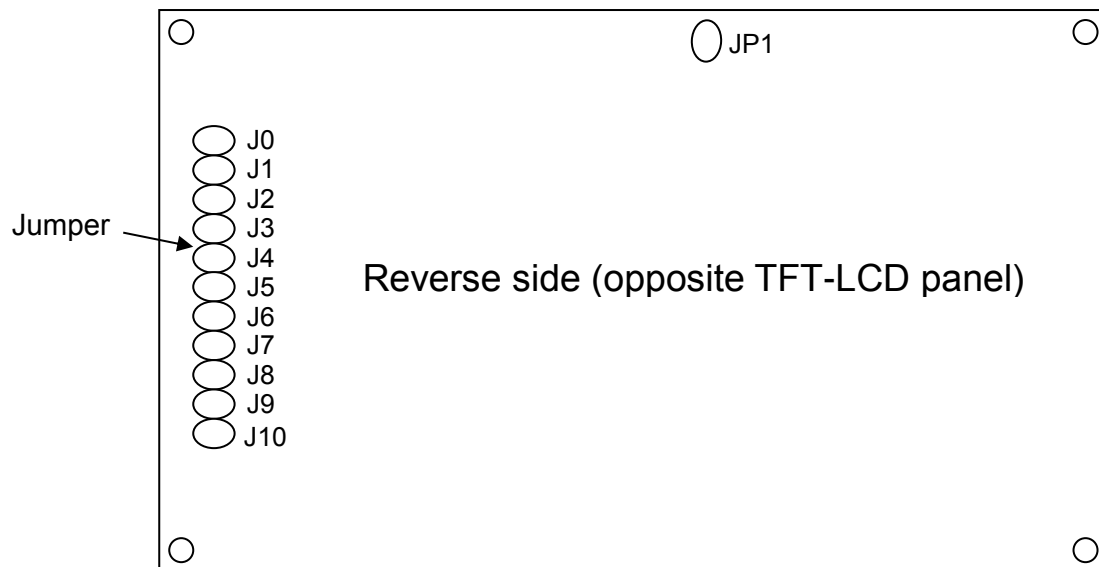

11 Connectors

11.1 Serial Interface & Power through-holes (CN9)

Pin No.	Signal name			Function	Direction
	UART	SPI	I ² C		
1	*RESET	*RESET	*RESET	Reset	Input
2	-	SCK	SCL	Serial Clock	Input
3	RxD	MOSI	SDA	Data Receive	Input/ Output
4	DTR	SBUSY	SBUSY	Display Busy	Output
5	DSR	SSEL	-	Host Busy	Input
6	TXD	MISO	-	Data Send	Output
7	TRDY	TRDY	TRDY	Target Ready	Output
8	VCC	VCC	VCC	Power Supply (5V)	-
9	GND	GND	GND	Ground	-

11.2 General Purpose I/O Port through-holes & Power through-holes (CN11)

Pin No.	Signal name	Function	Direction	Pin No.	Signal name	Function	Direction
1	VCC	Power supply (5V)	Input	2	3.3V	3.3V	Output
3	GPIO 15	Port 1	Input/Output	4	GPIO 14	Port 1	Input/Output
5	GPIO 13						
7	GPIO 11						
9	GPIO 9						
11	GPIO 7	Port 0	Input/Output	12	GPIO 6	Port 0	Input/Output
13	GPIO 5						
15	GPIO 3						
17	GPIO 1						
19	GND	Ground	Input	18	GPIO 0	Ground	Input
				20	GND	Ground	Input

11.3 Extension General Purpose I/O Port through-holes & Power through-holes (CN10)

Pin No.	Signal name	Function	Direction	Pin No.	Signal name	Function	Direction
1	VCC	Power supply (5V)	Input	2	3.3V	3.3V	Output
3	GPIO 25	Port 3	Input/Output	4	GPIO 24	Port 3	Input/Output
5	GPIO 23	Port 2					
7	GPIO 21						
9	GPIO 19						
11	GPIO 17			10	GPIO 18		
13	GND	Ground	Input	12	GPIO 16		
				14	GND	Ground	Input

11.4 USB Interface (CN3)

Pin No.	Signal name
1	VBUS
2	D-
3	D+
4	ID
5	GND

Note: To connect VBUS to Vcc (for 5V power supply), short JP1 (for CN3 VBUS).

11.5 Power through-holes (CN8)

Pin No.	Signal name	Function
1	Vcc	Power Supply (5V)
2	NC(*TEST)	No Connection (Factory test use only)
3	GND	Ground

* Factory use only (leave this pin open)

11.6 Connector Position

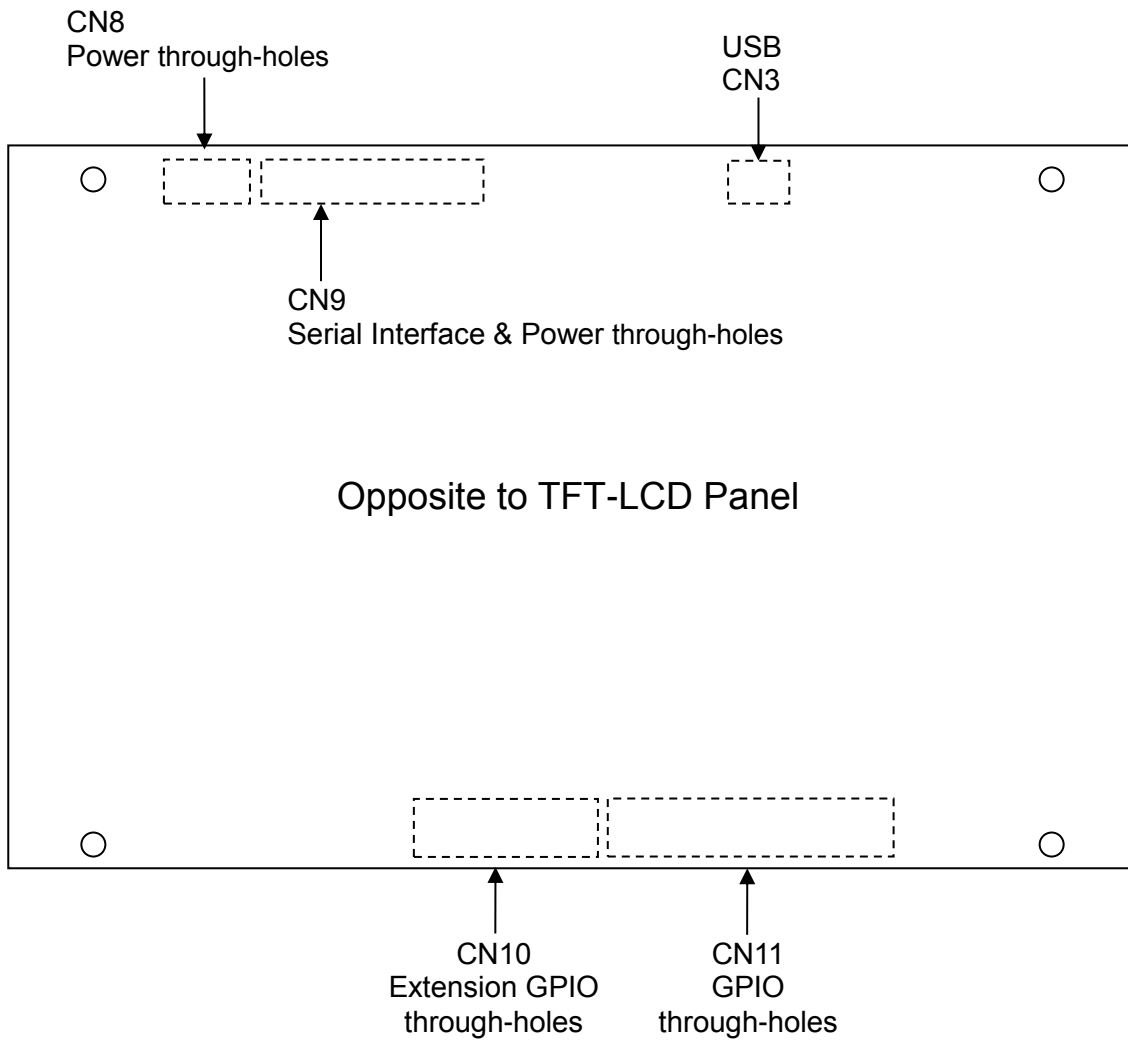

Notice for the Cautious Handling of LCD Modules

Handling and Usage Precautions:

Please carefully follow the appropriate product application notes and operation standards for proper usage, safe handling, and maximum performance.

[LCD panel is made of glass]

- Use caution to avoid breaking the LCD glass envelope, to prevent injury from sharp glass particles.
- Please design the PCB for the LCD module within 0.3 mm warping tolerance to avoid any forces that may damage the display due to PCB distortion causing a breakdown of the electrical circuit leading to LCD failure.

[Cable Connection]

- Do not unplug the power and/or data cables of LCD modules during operation, because unrecoverable damage may result.
- Sending input signals to the LCD module when it is not powered can cause I/O port damage.
- It is recommended to use a 30cm or shorter signal cable to prevent functional failures.

[Electrostatic Charge]

- LCD modules need electrostatic-free packaging and protection from electrostatic charges during handling and usage.

[Structure]

- During operation, LCD and LCD modules generate heat. Please consider sufficient heat radiation dissipation using heat sink solutions.
- Preferably, use UL-grade materials or components in conjunction with LCD modules.
- Warp and twist movement causes stress and may break LCDs and LCD modules. Please adhere to allowances within 0.3mm at the point of attachment.

[Power]

- Apply regulated power to the LCD module within specified voltages to protect from failures.
- LCD modules may draw in-rush current exceeding twice the typical current at power-on, so a power supply with sufficient capacity and quick starting of the power regulator is recommended.
- LCD module needs a specified voltage at the point of connection. Please use an adequate power cable to avoid a decrease in voltage. As a safety measure, a fuse or other over-current protection is recommended.

[Operating Consideration]

- A signal cable 30cm or less is recommended to avoid possible disturbances to the signal.

[Storage and Operating Environment]

- Please use LCD modules under the recommended specified environmental conditions. Salty, sulfuric and dusty environments may damage the LCD module even during storage.

[Disposal]

- LCD uses lead-containing materials (RoHS directive exempts these lead compounds in the glass for electronic devices). When discarding LCDs or LCD modules, please adhere to applicable laws and regulations.

[Other Cautions]

- Although the LCD module is designed to be protected from electrical noise, please plan your circuitry to exclude as much noise as possible.
- Do not reconstruct or repair the LCD module without our authorization. We cannot assure the quality or reliability of unauthorized reconstructed LCD modules.

Notice:

- We do not authorize the use of any patents that may be inherent in these specifications.
- Neither whole nor partial copying of these specifications is permitted without our approval. If necessary, please ask for assistance from our sales consultant.
- This product is not designed for military, aerospace, medical or other life-critical applications. If you choose to use this product for these applications, please ask us for prior consultation or we cannot accept responsibility for problems that may occur.

Revision history

Specification number	Date	Revision
DS-1940-0001-00	Jan. 29, 2016	Initial issue
DS-1940-0001-01	Feb. 19, 2016	<p>3.3 Electrical Characteristics General purpose I/O port MAX logic input voltage corrected: 5.5VDC → 3.3 VDC General purpose I/O port output permissible current, lower limits set to 0, upper limits changed, upper limits shown with minus sign where applicable. General purpose I/O port output permissible current symbols changed: liOH → liOHp, liOht, liOLp → liOLp, liOLt Power Supply condition descriptions added and symbols changed.</p> <p>4 Environmental Specifications Operating temperature description changed, and relative brightness graph added. Storage humidity range changed. Operating humidity range added.</p> <p>7 Applicable Specifications Document numbers corrected.</p> <p>8.2 Serial interface (CN9) Various clarifications.</p>
DS-1940-0001-02	Mar. 18, 2016	<p>8.1.1 USB Interface – Summary Added reference of USB VCOM Driver Installation Manual.</p>
DS-1940-0001-03	Jun. 13, 2016	<p>8.1.1 USB Interface – Summary Added reference to USB 2.0 Specification.</p> <p>8.1.3 USB Interface – Power Clarification of power-supply options Clarification of explanation</p>
DS-1940-0001-04	Jul. 21, 2016	<p>8.1 USB Interface (CN3) Automatic WinUSB support added. USB Serial number support added.</p> <p>8.2 Serial Interface (CN9) Buffer Capacity and SBUSY / DTR Signal Change Timing corrected.</p> <p>8.2.3 I2C Mode (J5 = SHORT, J6 = OPEN) Correction: General call address (00h) not supported. Data Read Sequence TRDY signal correction.</p> <p>8.3 Transmit data interface Added</p> <p>8.4 Reset Added</p>

X-ON Electronics

Largest Supplier of Electrical and Electronic Components

Click to view similar products for [TFT Displays & Accessories category](#):

Click to view products by [Noritake manufacturer](#):

Other Similar products are found below :

[F3ET2-005-150](#) [HDA430T-3G1H](#) [NB7W-KBA04](#) [NB-ATT01](#) [NB5Q-ATT01](#) [NB5Q-KBA04](#) [NB-CN001](#) [OAI-80038AA-2008-A](#) [315-U004B15300](#) [UMSH-8596MD-34T \(REV D\)](#) [TCG121WXLRXVNNANX35](#) [EIC-LCD-1080P](#) [T-55619GD065J-LW-ABN](#)
[TCG104SVLPEANN-AN30](#) [NL6448BC33-70](#) [NL6448BC20-30D](#) [NL10276BC16-06](#) [NL192108AC10-01D](#) [NL12880BC20-05BD](#)
[NL8060BC26-35BA](#) [NL8060BC31-50F](#) [TM070DDHG03-40](#) [PTPW16-070WV1S02](#) [PTPW17-070WV1S02](#) [PTPW16-084SV1S02](#)
[MTD0300ECP06DF-1](#) [DEM 320240T VMX-PW-N \(A-TOUCH\)](#) [DEM 480128B TMH-PW-N \(A-TOUCH\)](#) [DEM 480272P VMX-PW-N \(C-TOUCH\)](#) [DEM 480272Q VMX-PW-N \(A-TOUCH\)](#) [DEM 480272Q VMX-PW-N \(C-TOUCH\)](#) [DEM 640480E TMH-PW-N \(A-TOUCH\)](#)
[DEM 800480K1 TMH-PW-N \(A-TOUCH\)](#) [DEM 800480K1 TMH-PW-N \(C-TOUCH\)](#) [DEM 800480K2 TMH-PW-N \(A-TOUCH\)](#) [DEM 800480K3 TMH-PW-N \(C-TOUCH\)](#) [DEM 800480K4 TMH-PW-N \(A-TOUCH\)](#) [DEM 800480K4 TMH-PW-N \(C-TOUCH\)](#) [4DLCD-35480320-CTP-IPS](#) [4DLCD-35480320-IPS](#) [4DLCD-35480320-RTP-IPS](#) [4DLCD-50800480-CTP-IPS](#) [RFA6400E-AWH-DNG](#) [RFA6400E-AWH-MNN](#) [RFE430V-AZW-DNS](#) [RFF70VA2-1IW-DHS](#) [RFH700A8-AYH-MNN](#) [RFK101VF-1YH-LHG](#) [RFS390C-AIW-DNN](#) [RFS390C-AIW-DNS](#)