



序号 No	目 录 INDEX	页 page
1	概述 SCOPE	5
2	订货方式 HOW TO ORDER	5
3	主要特性表 MAIN SPECIFICATIONS	6
4	产品结构 PRODUCT STRUCTURE	7
5	纹波电流频率因子 RIPPLE CURRENT FREQUENCY COEFFICIENT	9
6	尺寸表、允许纹波电流 DIMENSIONS AND RIPPLE CURRENT	10
7	包装 PACKING	10
8	贮存方法 STORAGE METHODS	11
9	其他说明 OTHERS	12



产品特性 CHARACTERISTIC:

系列 Series	规格 Specification	尺寸 Size	容量偏差 Capacitance tolerance	纹波电流(mA rms) Ripple current(120Hz)	产品寿命 (hours) Load life	漏电流 (μ A) Leakage Current	损耗角正切 DF Dissipation Factor(25 $^{\circ}$ C,120Hz)
RX	47 μ F 35 V	5 \times 11	M (\pm 20%)	94 mA	1000 小时	16.45 μ A	0.14



1. 概述 SCOPE

1.1 概述 SCOPE

本承认书规定了铝电解电容器的技术规范。

This specification contains descriptions of the quality of aluminum electrolytic capacitors.

1.2 参考标准 APPLICABLE SPECIFICATION

本承认书参考 JISC-5141 和 JISC-5102 制定。

This specification is made based on the Japanese Industrial Standard JISC-5141 Characteristics and JIS C-5102.

1.3 工作温度范围 OPERATING TEMPERATURE RANGE

工作温度范围是电容器在施加额定工作电压条件下，可以长期可靠工作的环境温度范围。

Operating temperature range is the range of ambient temperature at which the capacitor can be operated continuously at rated voltage.

2. 订货方式 HOW TO ORDER

2.1 订货方式 HOW TO ORDER

①	②	③	④	⑤	⑥	⑦	⑧	⑨	⑩																																																																																																																																																		
8	470	LE	M	0511	RX	N	0	11	F																																																																																																																																																		
<table border="1" style="width: 100%; border-collapse: collapse;"> <thead> <tr> <th>代码 Code</th> <th>产品类别 Type</th> </tr> </thead> <tbody> <tr> <td>8</td> <td>成品 Product</td> </tr> <tr> <td>1</td> <td>素子 Element 裸品</td> </tr> <tr> <td>2</td> <td>Semifinished Product</td> </tr> </tbody> </table>	代码 Code	产品类别 Type	8	成品 Product	1	素子 Element 裸品	2	Semifinished Product	<table border="1" style="width: 100%; border-collapse: collapse;"> <thead> <tr> <th>代码 Code</th> <th>电压 Voltage</th> </tr> </thead> <tbody> <tr><td>LA</td><td>6.3</td></tr> <tr><td>LB</td><td>10</td></tr> <tr><td>LC</td><td>16</td></tr> <tr><td>LD</td><td>25</td></tr> <tr><td>LE</td><td>35</td></tr> <tr><td>LF</td><td>50</td></tr> <tr><td>LG</td><td>63</td></tr> <tr><td>LH</td><td>80</td></tr> <tr><td>MA</td><td>100</td></tr> <tr><td>MB</td><td>160</td></tr> <tr><td>MC</td><td>200</td></tr> <tr><td>MJ</td><td>220</td></tr> <tr><td>MD</td><td>250</td></tr> <tr><td>MF</td><td>350</td></tr> <tr><td>VA</td><td>400</td></tr> <tr><td>VB</td><td>450</td></tr> <tr><td>VC</td><td>500</td></tr> </tbody> </table>	代码 Code	电压 Voltage	LA	6.3	LB	10	LC	16	LD	25	LE	35	LF	50	LG	63	LH	80	MA	100	MB	160	MC	200	MJ	220	MD	250	MF	350	VA	400	VB	450	VC	500	<table border="1" style="width: 100%; border-collapse: collapse;"> <thead> <tr> <th>代码 Code</th> <th>尺寸 Dimensions Φ DxL(mm)</th> </tr> </thead> <tbody> <tr><td>0511</td><td>Φ 5x11</td></tr> <tr><td>AA12</td><td>Φ 6.3x12</td></tr> <tr><td>0812</td><td>Φ 8x12</td></tr> <tr><td>1012</td><td>Φ 10x12</td></tr> <tr><td>1016</td><td>Φ 10x16</td></tr> <tr><td>AB20</td><td>Φ 12.5x20</td></tr> <tr><td>1625</td><td>Φ 16x25</td></tr> <tr><td>1835</td><td>Φ 18x35</td></tr> </tbody> </table>	代码 Code	尺寸 Dimensions Φ DxL(mm)	0511	Φ 5x11	AA12	Φ 6.3x12	0812	Φ 8x12	1012	Φ 10x12	1016	Φ 10x16	AB20	Φ 12.5x20	1625	Φ 16x25	1835	Φ 18x35	<table border="1" style="width: 100%; border-collapse: collapse;"> <thead> <tr> <th>代码 Code</th> <th>商标 Trademark</th> </tr> </thead> <tbody> <tr> <td>N</td> <td>LH.NOVA</td> </tr> </tbody> </table>	代码 Code	商标 Trademark	N	LH.NOVA	<table border="1" style="width: 100%; border-collapse: collapse;"> <thead> <tr> <th>代码 Code</th> <th>内码 Internal Code</th> </tr> </thead> <tbody> <tr> <td>11</td> <td>105℃普通品 105℃ regular</td> </tr> <tr> <td>1S</td> <td>105℃特殊品 105℃ Special</td> </tr> <tr> <td>1E</td> <td>105℃普通品 PET 胶管 105℃ regular & PET Sleeve</td> </tr> <tr> <td>1F</td> <td>105℃凸台胶粒 PET 胶管 105℃ convex rubber & PET Sleeve</td> </tr> </tbody> </table>	代码 Code	内码 Internal Code	11	105℃普通品 105℃ regular	1S	105℃特殊品 105℃ Special	1E	105℃普通品 PET 胶管 105℃ regular & PET Sleeve	1F	105℃凸台胶粒 PET 胶管 105℃ convex rubber & PET Sleeve	<table border="1" style="width: 100%; border-collapse: collapse;"> <thead> <tr> <th>代码 Code</th> <th>标称容量 Nominal Capacitance</th> </tr> </thead> <tbody> <tr><td>R22</td><td>0.22uF</td></tr> <tr><td>1R0</td><td>1uF</td></tr> <tr><td>2R2</td><td>2.2uF</td></tr> <tr><td>220</td><td>22uF</td></tr> <tr><td>221</td><td>220uF</td></tr> <tr><td>223</td><td>22000uF</td></tr> <tr><td>470</td><td>47uF</td></tr> </tbody> </table>	代码 Code	标称容量 Nominal Capacitance	R22	0.22uF	1R0	1uF	2R2	2.2uF	220	22uF	221	220uF	223	22000uF	470	47uF	<table border="1" style="width: 100%; border-collapse: collapse;"> <thead> <tr> <th>代码 Code</th> <th>误差 Tolerance</th> </tr> </thead> <tbody> <tr><td>J</td><td>±5%</td></tr> <tr><td>K</td><td>±10%</td></tr> <tr><td>V</td><td>±²⁰/₁₀%</td></tr> <tr><td>M</td><td>±20%</td></tr> <tr><td>Q</td><td>±³⁰/₁₀%</td></tr> <tr><td>T</td><td>±⁵⁰/₁₀%</td></tr> <tr><td>A</td><td>特殊</td></tr> </tbody> </table>	代码 Code	误差 Tolerance	J	±5%	K	±10%	V	± ²⁰ / ₁₀ %	M	±20%	Q	± ³⁰ / ₁₀ %	T	± ⁵⁰ / ₁₀ %	A	特殊	<table border="1" style="width: 100%; border-collapse: collapse;"> <thead> <tr> <th>代码 Code</th> <th>型号 Series</th> </tr> </thead> <tbody> <tr> <td>RX</td> <td>CD81</td> </tr> </tbody> </table>	代码 Code	型号 Series	RX	CD81	<table border="1" style="width: 100%; border-collapse: collapse;"> <thead> <tr> <th>代码 Code</th> <th>产品脚型 Lead Forming Type</th> </tr> </thead> <tbody> <tr><td>0</td><td>散装品 Bulk</td></tr> <tr><td>T</td><td>5mm 贴片编带品 5mm Chip tape</td></tr> <tr><td>A</td><td>(Φ4-Φ6.3)2.5mm 脚距 编带品; 2.5mmTape</td></tr> <tr><td>F</td><td>(Φ4-Φ8)5mm 脚距编 带品; 5mmTape</td></tr> <tr><td>P</td><td>直径Φ≥Φ8mm 直脚 方式编带品 original type(vertical) tape</td></tr> <tr><td>M</td><td>5mm 成型剪脚品 5mm Lead forming</td></tr> <tr><td>C</td><td>原脚距型成型剪脚品 C Lead forming</td></tr> <tr><td>B</td><td>B 型成型剪脚品 B Lead forming</td></tr> <tr><td>D</td><td>(Φ4-Φ5)2.5mm 成型 剪脚品 Lead forming</td></tr> </tbody> </table>	代码 Code	产品脚型 Lead Forming Type	0	散装品 Bulk	T	5mm 贴片编带品 5mm Chip tape	A	(Φ4-Φ6.3)2.5mm 脚距 编带品; 2.5mmTape	F	(Φ4-Φ8)5mm 脚距编 带品; 5mmTape	P	直径Φ≥Φ8mm 直脚 方式编带品 original type(vertical) tape	M	5mm 成型剪脚品 5mm Lead forming	C	原脚距型成型剪脚品 C Lead forming	B	B 型成型剪脚品 B Lead forming	D	(Φ4-Φ5)2.5mm 成型 剪脚品 Lead forming	<table border="1" style="width: 100%; border-collapse: collapse;"> <thead> <tr> <th>代码 Code</th> <th>胶管颜色 Sleeve Color</th> </tr> </thead> <tbody> <tr><td>0</td><td>黑色 Black</td></tr> <tr><td>1</td><td>深蓝色 Deep-blue</td></tr> <tr><td>4</td><td>紫色 Purple</td></tr> <tr><td>5</td><td>墨绿色 Black-green</td></tr> <tr><td>7</td><td>棕色 Brown</td></tr> <tr><td>9</td><td>绿色 Green</td></tr> </tbody> </table>	代码 Code	胶管颜色 Sleeve Color	0	黑色 Black	1	深蓝色 Deep-blue	4	紫色 Purple	5	墨绿色 Black-green	7	棕色 Brown	9	绿色 Green
代码 Code	产品类别 Type																																																																																																																																																										
8	成品 Product																																																																																																																																																										
1	素子 Element 裸品																																																																																																																																																										
2	Semifinished Product																																																																																																																																																										
代码 Code	电压 Voltage																																																																																																																																																										
LA	6.3																																																																																																																																																										
LB	10																																																																																																																																																										
LC	16																																																																																																																																																										
LD	25																																																																																																																																																										
LE	35																																																																																																																																																										
LF	50																																																																																																																																																										
LG	63																																																																																																																																																										
LH	80																																																																																																																																																										
MA	100																																																																																																																																																										
MB	160																																																																																																																																																										
MC	200																																																																																																																																																										
MJ	220																																																																																																																																																										
MD	250																																																																																																																																																										
MF	350																																																																																																																																																										
VA	400																																																																																																																																																										
VB	450																																																																																																																																																										
VC	500																																																																																																																																																										
代码 Code	尺寸 Dimensions Φ DxL(mm)																																																																																																																																																										
0511	Φ 5x11																																																																																																																																																										
AA12	Φ 6.3x12																																																																																																																																																										
0812	Φ 8x12																																																																																																																																																										
1012	Φ 10x12																																																																																																																																																										
1016	Φ 10x16																																																																																																																																																										
AB20	Φ 12.5x20																																																																																																																																																										
1625	Φ 16x25																																																																																																																																																										
1835	Φ 18x35																																																																																																																																																										
代码 Code	商标 Trademark																																																																																																																																																										
N	LH.NOVA																																																																																																																																																										
代码 Code	内码 Internal Code																																																																																																																																																										
11	105℃普通品 105℃ regular																																																																																																																																																										
1S	105℃特殊品 105℃ Special																																																																																																																																																										
1E	105℃普通品 PET 胶管 105℃ regular & PET Sleeve																																																																																																																																																										
1F	105℃凸台胶粒 PET 胶管 105℃ convex rubber & PET Sleeve																																																																																																																																																										
代码 Code	标称容量 Nominal Capacitance																																																																																																																																																										
R22	0.22uF																																																																																																																																																										
1R0	1uF																																																																																																																																																										
2R2	2.2uF																																																																																																																																																										
220	22uF																																																																																																																																																										
221	220uF																																																																																																																																																										
223	22000uF																																																																																																																																																										
470	47uF																																																																																																																																																										
代码 Code	误差 Tolerance																																																																																																																																																										
J	±5%																																																																																																																																																										
K	±10%																																																																																																																																																										
V	± ²⁰ / ₁₀ %																																																																																																																																																										
M	±20%																																																																																																																																																										
Q	± ³⁰ / ₁₀ %																																																																																																																																																										
T	± ⁵⁰ / ₁₀ %																																																																																																																																																										
A	特殊																																																																																																																																																										
代码 Code	型号 Series																																																																																																																																																										
RX	CD81																																																																																																																																																										
代码 Code	产品脚型 Lead Forming Type																																																																																																																																																										
0	散装品 Bulk																																																																																																																																																										
T	5mm 贴片编带品 5mm Chip tape																																																																																																																																																										
A	(Φ4-Φ6.3)2.5mm 脚距 编带品; 2.5mmTape																																																																																																																																																										
F	(Φ4-Φ8)5mm 脚距编 带品; 5mmTape																																																																																																																																																										
P	直径Φ≥Φ8mm 直脚 方式编带品 original type(vertical) tape																																																																																																																																																										
M	5mm 成型剪脚品 5mm Lead forming																																																																																																																																																										
C	原脚距型成型剪脚品 C Lead forming																																																																																																																																																										
B	B 型成型剪脚品 B Lead forming																																																																																																																																																										
D	(Φ4-Φ5)2.5mm 成型 剪脚品 Lead forming																																																																																																																																																										
代码 Code	胶管颜色 Sleeve Color																																																																																																																																																										
0	黑色 Black																																																																																																																																																										
1	深蓝色 Deep-blue																																																																																																																																																										
4	紫色 Purple																																																																																																																																																										
5	墨绿色 Black-green																																																																																																																																																										
7	棕色 Brown																																																																																																																																																										
9	绿色 Green																																																																																																																																																										



2.2 标记 MARKING

2.2.1 在电容器体上应注明如下内容 The following items shall be marked indelibly on the surface of capacitor:

- (1) 生产厂商商标 Manufacturer's name or trade mark. _____ →
- (2) 电容量 Capacitance. _____ →
- (3) 工作电压 Rated voltage. _____ →
- (4) 负极标志 Polarity of the terminals. _____ →

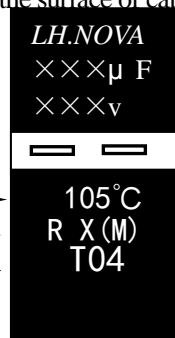

- (5) 上限工作温度 Maximum operating temperature. 示例 Sample: 105°C →
- (6) 系列代码及容量偏差代码 Series Code & Capacitance tolerance Code →

示例 Sample: RX (M)
系列代码 容量偏差代码

- (7) 生产日期 Produce date 示例 Sample: T 04
YEAR MONTH

I、年份代码表示原则: YEAR CODE:

年份 Year	2001	2002	2003	2004	2020	2026	2027	2028	2052
代码 Code	A	B	C	D		T		Z	A	B		Z

II、月份代码表示原则: MONTH CODE:

月份 Month	1 月份	4 月份	7 月份	10 月份
代码 Code	01	04	07	10

(8) PVC 胶管 PVC SLEEVE

2.2.2 标记颜色 Marking color

套管颜色 Sleeve color: 黑色 Black

标记颜色 Marking color: 白色 White.

3、主要特性表 MAIN SPECIFICATIONS

项目 Item	主要特性 Performance Characteristics	
额定工作电压范围 Rated Voltage Range	6.3~100V.DC	160~500V.DC
使用温度范围 Operating Temperature Range	-40°C~+105°C	-40°C~+105°C
标称静电容量范围 Nominal Capacitance Range	0.1~22000μ F	0.47~220μ F
静电容量允许偏差 Capacitance Tolerance	±20% (M, +25°C, 120Hz)	
漏电流 Leakage Current (25°C)	额定工作电压(V) Rated working voltage	6.3~100 160~500
	漏电流 Leakage current	2 分钟后 I≤0.01CV 或 3(μ A),取 最大值 After 2 min. I≤0.01CV or 3(μ A), Whichever is greater.
C: 标称静电容量 (μ F) Nominal Capacitance in μ F V: 额定工作电压 (V) Rated working voltage in V		
损耗角正切 DF Dissipation Factor	额定工作电压(V) Rated working voltage	6.3 10 16 25 35 50 63 100 160~500
	DF(MAX) (25°C,120Hz)	0.26 0.22 0.18 0.16 0.14 0.12 0.10 0.08 0.15
当容量值大于 1000μ F 时, 每增加 1000μ F, DF 值加 0.02 For capacitance of more than 1000μ F, add 0.02 for every increase of 1000μ F.		



项目 Item	主要特性 Performance Characteristics																
浪涌电压 Surge Voltage	额定工作电压(V) Rated working voltage	6.3	10	16	25	35	50	63	100	160	200	250	350	400	450	500	
	浪涌电压(V) Surge voltage	8	13	20	32	44	63	79	125	200	250	300	400	450	500	550	
温度特性 Temperature Stability	额定工作电压(V) Rated working voltage		6.3	10	16	25	35	50	63	100	160~250	350~500					
	阻抗比(120Hz) Impedance Ratio	z-25°C/z+25°C	4	3	2	2	2	2	2	2	2	3	6				
		z-40°C/z+25°C	8	6	4	4	3	3	3	3	3	--	--				
高温负荷特性 Load life	<p>在+105°C 环境中施加额定工作电压和最大允许纹波电流 1000 小时后,电容器的性能符合下面要求:</p> <p>After application of rated working voltage with max permissible ripple current specified at +105°C for 1000 hours, capacitors meet the characteristics requirements measured at +25°C listed at below:</p> <p>1、电容量变化率:±25%初始测量值以内 Capacitance change : ±25% initial measured value</p> <p>2、漏电流: ≤初始规定值 Leakage current: ≤initial specified value</p> <p>3、损耗角正切值≤200%倍初始规定值 Dissipation factor: ≤200% initial specified value</p>																
	高温贮存特性 Shelf life	<p>在+105°C环境无负荷放置 1000 小时后, 电容器的性能符合下面要求</p> <p>After leaving capacitors under no load at +105°C for 1000 hours, capacitors meet the characteristics listed as below:</p> <p>1、电容量变化率:±20%初始测量值以内 Capacitance change : ±20% initial measured value</p> <p>2、漏电流: ≤200%初始规定值 Leakage current: ≤200% initial specified value</p> <p>3、损耗角正切值≤200%倍初始规定值 Dissipation factor: ≤200% initial specified value</p>															

4. 产品结构 PRODUCT STRUCTURE (mm)

4.1 外形尺寸 SHAPE AND DIMENSIONS

β	±0.5			±1.0					
ΦD	5	6.3	8	10	12.5	16	18	22	
F±0.5	2.0	2.5	3.5	5.0			7.5		10.0
Φd±0.1	0.5		0.6			0.8			
L	11,12	12,16	12,16,20	16,20,25,30	16,20,25,30,35	20,25,30,35,40	25,30,35,40		
	L±2.0								

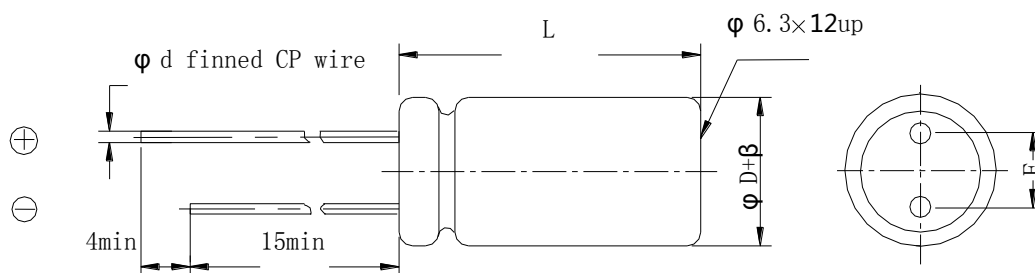



4. 1. 1 内部构造图及构成材料 INTERNAL CONSTRUCTION AND COMPONENTS

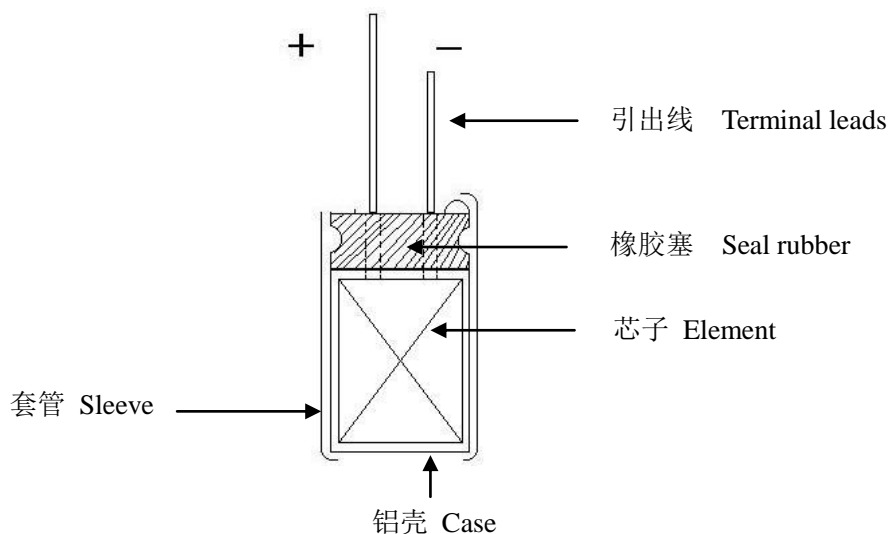

芯子分解图 Dicomposing figure of clement

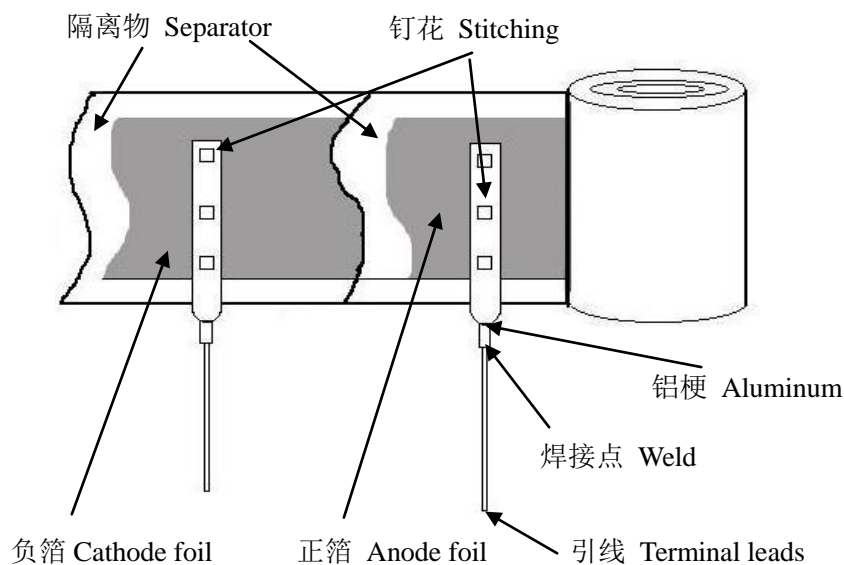

序号 Components	材料.规格.处理 Materials.Finish/Specification	序号 Components	材料.规格.处理 Materials.Finish/Specification
1 铝壳 Case	铝 Aluminum	5 隔离物 Separator	电解纸 Paper
2 套管 Sleeve	胶管(PVC) Sleeve(PVC)	6 正箔 Anode foil	高纯铝 Fine Aluminum
3 封口塞 Seal	合成橡胶 Synthesized rubber	7 负箔 Cathode foil	铝 Aluminum
4 引线 Terminal lead	CP线(铁+锡) CP wire (Fe+Sn)	8 电解液 Electrolyte	有机溶剂 Organic Solvent etc



4.2 引线编带 TAPING METHOD (mm)

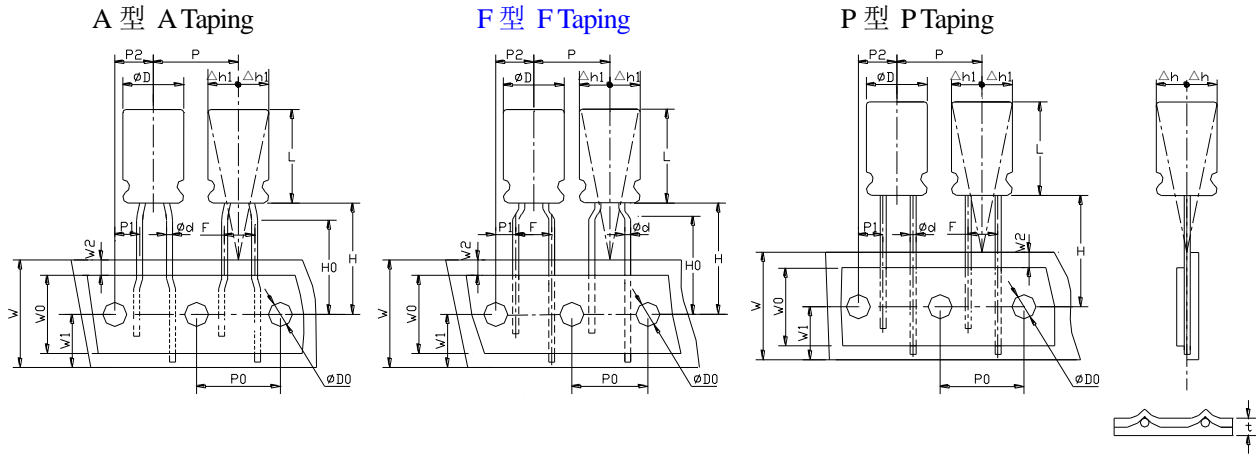

单位: mm

外径 Case Dia 项目及误差 Item Tolerance	Φ4	Φ5	Φ6.3	Φ4	Φ5	Φ6.3	Φ8	Φ8	Φ10	Φ12~Φ13	Φ16~Φ18
L+2max	5~16		5~16			7~20	7~20	9~20	16-25	16-25	
代码 Taping code	A		F			P					
Φd±0.05	0.45~0.50		0.45~0.50			0.60		0.60	0.60	0.60	0.8
P±1.0	12.70		12.70			12.70		12.70	15.0	30.0	
P ₀ ±0.2	12.70		12.70			12.70		15.0	15.0		
P ₁ ±0.5	5.10		3.85			4.60	3.85	5.00	3.75		
P ₂ ±0.5	6.35		6.35			6.35		7.50			
F± ^{0.5} _{0.2}	2.50		5.00			3.50	5.00±0.5		7.5±0.5		
H±0.5	18.5										
H ₀ ±0.5	16.5		16.5								
W±0.3	18.00										
W ₀ min	10.00										
W ₁ ±0.5	9.00										
W ₂ max	3.00										
ΦD ₀ ±0.2	4.00										
Δh max	0.50										
Δh ₁ max	0.50										
t±0.2	0.60										

5. 纹波电流频率因子 RIPPLE CURRENT FREQUENCY COEFFICIENT

Freq (Hz) C.V(μ F.V)	50 (60)	100 (120)	1K	≥10K
0.1~1.5	0.50	1.00	1.30	1.50
2.2~6.8	0.65	1.00	1.30	1.50
10~82	0.80	1.00	1.30	1.50
100~1500	0.80	1.00	1.15	1.20
2200~3300	0.80	1.00	1.10	1.15



6. 尺寸表、允许纹波电流 DIMENSIONS AND RIPPLE CURRENT (RX)

系列 Series	规格 Specification	尺寸(mm) Size	容量偏差 Capacitance tolerance	纹波电流(mA rms) Ripple current(120Hz)
RX	47 μ F 35V	$\Phi 5 \times 11$	M ($\pm 20\%$)	94 mA

(1) 外形尺寸 Case Size D \times L(mm)

(2) 最大允许纹波电流 Max allowable ripple current (mA rms +105 $^{\circ}$ C,120Hz)

6.1 客户料号与风华物料对照表 Customer P/N and Fenghua P/N collate list

客户 P / N	风华 P / N
--	8470LEM0511RXN011F

7. 包装 PACKING

7.1 包装标签 PACKING LABEL

(标签样版)



规格、尺寸 Specification and dimensions →

批号的填写 LOT:

1	2	3	4	5	6	7	8	9	10	11	12	13	14
---	---	---	---	---	---	---	---	---	----	----	----	----	----

类别 年份 月份 日期 区别号
Sort Year Month Date Discriminate mark

流传单号码
Sequence number

7.2 编带产品按下图包装 Taped capacitors are packed into carton, according to the following drawing.

Φ D	Qty. (Pcs)	L(电容高度) ≤ 22 mm	L(电容高度) $= 25 \pm 2$ mm
		L \times W \times H(mm)	L \times W \times H(mm)
$\Phi 5$	2000	328 \times 235 \times 50	328 \times 235 \times 57
$\Phi 6.3$	1500		
$\Phi 8$	1000		
$\Phi 10$	600		
$\Phi 12.5$	400		
$\Phi 16$	250		
$\Phi 18$	200		

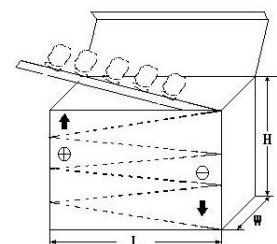



7.3 散包装按下图包装方式

Bulk packing capacitors are packed into PVC bag, inner box and carton according to the following drawings.

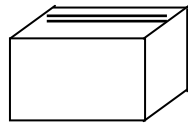

内盒
inner box



外箱
carton

7.4 散装、编带品外包装箱不干胶标签，实用尺寸为 167.5mmX97.5mm。

The dimension of the label on the carton is 167.5mmX97.5mm

(标签样版)



8. 贮存方法 STORAGE METHODS

8.1 请保管在室温 5~35℃，湿度 75% 以下的环境。

We recommend the following conditions for storage: Ambient temperature: 5~35℃, Ambient humidity: Less than 75% RH;

(1) 产品储存期限: ≤12 个月; Storage life: ≤12 months;

(2) 产品储存期限超 12 个月时, 需充电后再使用; If storage life time is over 12 months, the products need to be recharged;

(3) 产品储存时间超过 3 年的应报废处理; If storage life time is over three years, the product need to be discarded;

(4) 库存有效期以套管上印刷的时间开始计算; Expiry date: calculating from the date marked on the sleeve;

(5) 请尽量以包装状态保管; Please keep capacitors in the original package;

(6) 请避免在以下环境中保管: Avoid storing the capacitors under such circumstances:

*① 溅水、高温高湿及结露的环境。Environment of water splashing, high temperature, high humidity and dewing;

* 溅油、或者充满气体油成分的环境。The environment that splashes oil, or is filled with gas oil;

*③ 充满酸性有毒气体 (硫化氢、亚硫酸、亚硝酸、氯、溴、溴化甲烷等) 的环境。With full of acid toxic gases environment such as (hydrogen sulfide, sulfurous acid, nitrous acid, chlorine, bromine, methyl bromide, etc.)

8.2 当电容器长期储存后, 漏电流会升高, 温度越高, 漏电流上升越快, 因此应注意储存环境。如铝电解电容器的漏电流上升对电路有不良影响, 请在使用前充电处理。

Leakage current tends to increase when capacitors have been stored for long period of time. The higher temperature, the higher leakage current increase. Please take caution when selecting the storage location. The leakage decrease gradually as voltage is applied to the capacitor. The capacitor is subjected to aging before using, leakage may cause problems in the circuit.

8.3 如果没有其他规定, 标准的测试、检验环境条件如下所示:

环境温度: 5 至 35℃; 相对湿度: 45 至 75%; 大气压力: 86kpa 至 106kpa。

如果对测试结果有异议, 可以在以下条件测试:

环境温度: 25±2℃; 相对湿度: 60 至 70%; 大气压力: 86kpa 至 106kpa。

Unless otherwise specified, the standard range of atmospheric conditions for making measurements and tests are as follows.

Ambient temperature: 5 to 35℃ Relative humidity: 45 to 75% Air pressure: 86kpa to 106kpa.

If there may be doubt on the results, measurements shall be made within the following limits.

Ambient temperature: 25±2℃ Relative humidity: 60 to 70% Air pressure: 86kpa to 106kpa.



9. 其它说明 OTHERS

9.1 铝电解电容器使用注意事项 Important information on the application of aluminium electrolytic capacitors

(1). 直流铝电解电容器应按正确的极性使用 DC electrolytic capacitors are polarized

当直流铝电解电容器被反极性接入电路时, 电容器会导致电子线路短路, 由此产生的电流会引致电容器损坏。若电路中有可能在负引线施加正极电压, 请选用无极性产品。

When reverse voltage is applied on DC electrolytic capacitor, the capacitor will become short-circuited please use non-polarized capacitors in the circuit or the capacitor will be damage due to abnormal current flows through the capacitors since the circuit where the positive voltage may be applied to the cathode terminal.

(2). 在额定工作电压以下作用 Use capacitor within rated voltage

当电容器上所施加电压高于额定工作电压时, 电容器的漏电流将上升, 其电气特性将在短时期内劣化直至损坏。请注意电压峰值勿超出额定工作电压。

When capacitor is used at higher voltage than the rated voltage, leakage current increases, characteristics drastically deteriorate and damage in a short period may occur as a result. Please take extra caution that the peak voltage should not exceed the rated voltage.

(3). 作快速充放电使用 Charge and discharge application.

当常规电容器被用作快速充电用途。其使用寿命可能会因为容量下降, 温度急剧上升等而缩减

When aluminum electrolytic capacitors for general purpose are employed in rapid charge and discharge application, its life may be shorted by capacitance decreasing, heat rising, etc.

(4). 电容器贮存 Store the capacitor.

当铝电解电容器作了长期贮存后, 其漏电流通常升高, 贮存温度愈高, 漏电流上升愈快。因此应注意贮存环境的选择, 在电容器上施加电压后, 漏电流值将不断下降, 在铝电解电容器的漏电流值上升对电路有不良影响的, 请在使用前充电处理。

I creased leakage current is common in aluminum capacitors which have been stored for long period of time. The Higher the storage temperature, the higher the leakage current increase, therefore please take precautions concerning the storage location. The leakage current decreases gradually as voltage is applied to the capacitor. In cases where increased leakage current causes problems in the circuit, apply voltage (aging) before using.

(5). 施加纹波电流应小于额定值 Ripple current applied to capacitor should not exceed the rated value.

施加纹波电流超过额定值后, 会导致电容器体过热, 容量下降, 寿命缩短。所施加纹波电压的峰值应小于额定工作电压。

Excessive heat will reduce capacitance and result in shortened life of capacitor if ripple currents exceeding the specified rated value are applied. The peak value of the ripple voltage should be less than the rated voltage.

(6). 使用环境温度 Ambient temperature.

铝电解电容器的使用寿命会受到环境温度的影响。据科学统计, 使用环境温度下降 10℃ 其使用寿命增加 1 倍。

Its ambient temperature closely affects the life of an aluminum electrolytic capacitor. It is generally stated, that life doubles for each 10℃ decrease in temperature.

(7). 引出线强度 Lead stress

当拉力施加到电容器引出线, 该拉力将作用于电容器内部, 这将导致电容器内部短路, 开路或漏电流上升。在电容器焊装到电路板, 请勿强烈摇动电容器。

When a strong force is applied to the lead wires or terminals, stress is put on the internal connections. This may result in short circuit, open circuit or increased leakage current. It is not advisable to bend or handle a capacitor after it has been soldered to the PCB board.

(8). 焊接过程耐热性 Heat resistance at the soldering process

铝电解电容器装至电路板进行浸焊或波峰焊时, 其塑料套管可能因焊接时间过长、温度过高而发生破裂或二次收缩。

In the dip soldering process of PCB board with aluminum electrolytic capacitors mounted, secondary shrinkage or crack of PVC sleeve may be observed when solder temperature is too high or dipping time is too long.

(9). 电路板的安装孔距及安装位置 Hole pitch and position of PCB board.

电路板安装孔的设计应与产品说明书的引脚间距相一致, 如果将电容器强行插入孔距不配套的电路板, 那么会有应力作用于引出线, 这将导致短路或漏电流上升。

PCB board must be designed so its hole coincides with the lead pitch (lead spacing) of the capacitor specified by the catalog or specifications. When a capacitor is forcibly inserted into an unmatched hole, a stress is put on the leads. This could result in a short circuit or increased leakage current.

9.2 本产品不含铅、镉等元素 This product does not include Plumbum or Cadmium.

X-ON Electronics

Largest Supplier of Electrical and Electronic Components

Click to view similar products for [nova manufacturer](#):

Other Similar products are found below :

[CCR-121](#) [SMC-36](#) [CCC-21](#) [8101LGM1012WPN081P](#) [8470LEMAA07SSN0110](#) [8102LAM0812LEN011P](#) [8470LEM0511RXN011F](#)
[8101LFM0812RXN0110](#)