

Bearing Replacement Guide

Customer Service • Manufacturing • Technical Support • Warehousing



AM7B



Bearing Replacement Guide



Worldwide Sales Offices

NSK Ltd.—Headquarters, Tokyo, Japan Americas & Europe Department Asia Marketing & Sales Department	www.nsk.com tel: 03-3779-7120 tel: 03-3779-7121	Auckland 4992	tel: (09) 276-	Turkey: NSK Bearings Middle East Trading Co., Ltd. Istanbul	tel: 90-216-442-7106
Africa South Africa: NSK South Africa (Pty) Ltd. Johannesburg	tel: (011) 458 3600	Philippines: NSK representative office Manila	tel: 02-759-6246	United Kingdom: NSK Bearings Europe Ltd. Peterlee, England	tel: 0191-586-6111
Asia and Oceania Australia: NSK Australia Pty. Ltd. Melbourne	www.nskaustralia.com.au tel: (03) 9764-8302	Singapore: NSK International (Singapore) Pte Ltd. Singapore	tel: (65) 273 0357	NSK European Technology Center., Ltd. Newark, England	tel: 0163-660-5123
China: NSK Hong Kong Ltd. Hong Kong	www.cn.nsk.com tel: 2 7 3 9 - 9 9 3 3	Taiwan: Taiwan NSK Precision Co., Ltd. Taipei	tel: (65) 278 1711	NSK UK Ltd. Newark, England	tel: 0163-660-5123
Kunshan NSK Co., Ltd. Kunshan	tel: 0520-7305654	Thailand: NSK Bearings (Thailand) Co., Ltd. Bangkok	tel: 02-2591-0656	NSK Steering Systems Europe Ltd. Coventry, England	tel: 024-76-588588
Guizhou HS NSK Bearings Co., Ltd. Anshun	tel: 0853-3521505	Chonburi	tel: 02-6412150-58 tel: (038) 214-317-8	North and South America NSK Americas, Inc. (American Headquarters) Ann Arbor, Michigan, U.S.A.	tel: 734-913-7500
NSK (Shanghai) Trading Co., Ltd. Shanghai	tel: 021-62099051	SNNS Co., Ltd. Chachoengsao 343-350	tel: (038) 522-	Argentina: NSK Argentina SRL Buenos Aires	tel: 011-4762-6556 www.br.nsk.com
NSK representative office Beijing	tel: 010-6590-8161	Europe NSK Europe Ltd. (European Headquarters) (Maidenhead, England)	www.eu.nsk.com tel: 0162-850-9800	Brazil: NSK Brasil Ltda. São Paulo	tel: 011-3269-4700 www.ca.nsk.com
NSK representative office Shanghai	tel: 21-6209-9051	France: NSK France S.A. Paris	tel: 01 30 57 39 39	Canada: NSK Canada Inc. Toronto	tel: 905-890-0740
NSK representative office Guangzhou	tel: 020-8732-0583	Germany: NSK Deutschland GmbH Düsseldorf	tel: 02102-481-0	Mexico: NSK Rodamientos Mexicana, S.A. de C.V. Mexico City	tel: 5-301-2741 www.us.nsk.com
NSK representative office Anshun	tel: 0853-3522522	Stuttgart	tel: 0771-79082-277	United States of America: NSK Corporation Ann Arbor, Michigan	tel: 734-913-7500
India: Rane NASTECH Ltd. Chennai	tel: 04114-65313, 65314, 65365, 66002	Munderkingen	tel: 0 7 3 9 3 - 5 4 0	Sales Offices: Ann Arbor, Michigan	tel: 734-913-7500
NSK representative office Chennai	tel: 044-4334732	Italy: NSK Italia S.P.A. Milano	tel: 02-995-191	Cerritos, California	tel: 562-926-2975
Indonesia: P.T. NSK Bearings Manufacturing Indonesia Jakarta	tel: 021-898-0155	Poland: NSK Europe Ltd. Warsaw Liaison Office Warsaw	tel: 48-22-645-1525, 1526	NSK American Technical Center Ann Arbor, Michigan	tel: 734-913-7500
Korea: NSK Korea Co., Ltd. Seoul	www.kr.nsk.com tel: 02-3287-0300	NSK Iskra S.A. Kielce	tel: 48-41-366-6111	NSK Precision America, Inc. Addison, Illinois	www.npa.nsk.com tel: 630-620-8500
NSK Korea Co., Ltd., Changwon Plant Changwon	tel: 0551-287-6001	Spain: NSK Spain S.A. Barcelona	tel: 93-575-4041	NSS America Bennington, Vermont	tel: 802-442-5448
Malaysia: NSK Bearings (Malaysia) Sdn. Bhd. Kuala Lumpur	tel: 03-7958-4396			NSK Latin America Inc. Miami, Florida	www.la.nsk.com tel: (305) 477-0605
NSK Micro Precision (M) Sdn. Bhd. Kuala Lumpur	tel: 03-961-6288				
New Zealand: NSK New Zealand Ltd.	www.nsk.co.nz				

NSK Ltd. has a basic policy not to export any products or technology designated as controlled items by export-related laws. When exporting the products in this brochure, the laws of the exporting country must be observed. Specifications are subject to change without notice and without any obligation on the part of the manufacturer. Every care has been taken to ensure the accuracy of the data contained in this brochure, but no liability can be accepted for any loss or damage suffered through errors or omissions. We will gratefully acknowledge any additions or corrections.

DISTRIBUTED BY

NSK Corporation Sales Locations

www.us.nsk.com

Ann Arbor
4200 Goss Road
Ann Arbor, MI 48105
800-675-9930

Cerritos
13921 Bettencourt Street
Cerritos, CA 90703
800-421-1458

www.tec.nsk.com

Product Service Guide

INTRODUCTION

How to Order Replacement Bearings 2
 Things You Should Know About NSK 3
 Other Product Capabilities 5

BALL BEARINGS

Table of Contents 6
 Introduction 7
 Nomenclature & Interchange 8
 Application Information 11
 Bearing Tables 12

CYLINDRICAL ROLLER BEARINGS

Table of Contents 48
 Introduction 49
 Nomenclature & Interchange 50
 Application Information 51
 Bearing Tables 52

SPHERICAL ROLLER BEARINGS

Table of Contents 64
 Introduction 65
 Nomenclature & Interchange 66
 Application Information 69
 Bearing Tables 70

TAPERED ROLLER BEARINGS

Table of Contents 100
 Introduction 100
 Nomenclature & Interchange 102
 Application Information 103
 Bearing Tables 104

THRUST BEARINGS

Table of Contents 138
 Introduction 138
 Nomenclature & Interchange 139
 Application Information 141
 Bearing Tables 142

SPLIT PILLOW BLOCKS

Table of Contents 154
 Introduction 155
 Nomenclature & Interchange 156
 Application Information 157
 Bearing Tables 158

SUPER PRECISION BEARINGS

Table of Contents 182
 Introduction 183
 Nomenclature & Interchange 184
 Application Information 189
 Bearing Tables 190

LINEAR MOTION

Table of Contents 228
 Introduction 229
 Nomenclature & Interchange 231
 Application Information 233
 Bearing Tables 234

ROLLING MILL BEARINGS

Table of Contents 282
 Introduction 283
 Nomenclature 284
 Description and Features 286
 Application Drawings 286

ENGINEERING SECTION

Table of Contents 298
 Appendices 356
 Part Number Index 360
 Conversion Factors 366

How to Order Replacement Bearings

Ordering the correct replacement bearing is a critical task – but one that is not difficult if you take time to gather the right information. Just follow these steps:

- **First** — IDENTIFY — the type of bearing you need to replace.
 - Ball Bearing – Single Row, Double Row, Angular Contact
 - Roller Bearing – Cylindrical, Spherical, Tapered
 - Thrust Bearing – Ball or Roller
 - Split Pillow Block – Pillow Blocks
 - Super Precision – Angular Contact Ball, Cylindrical Roller, Ball Screw Support
 - Linear Motion – Linear Guides, Ball Screws, Mono Carriers

- **Second** — LOCATE — the identification number on the bearing.

Bearing identification numbers are usually located on the inner ring face, outer ring face or bearing O.D. Mounted units are identified by a number tag fastened to the unit or by a housing number cast into the housing cap.

- **Third** — MEASURE — if you need to.
 - If a bearing identification number is not legible, you will need to determine the following:
 1. Inner ring bore (inside diameter)
 2. Outer ring outside diameter
 3. Inner width and outer width (these may be different)
 4. Shape of the bore and/or outside diameter of bearing – spherical, tapered or cylindrical

- **Fourth** — RECORD — additional relevant information.
 - The more information available, the easier it will be to identify the replacement bearing needed. Record:
 1. Unique features such as lubrication holes, snap ring grooves, machined shoulders, etc.
 2. Application/equipment data

- **Fifth** — LOOK — in the appropriate section of the catalog.
 1. Ball Bearings
 2. Cylindrical Roller Bearings
 3. Spherical Roller Bearings
 4. Tapered Roller Bearings
 5. Thrust Bearings
 6. Split Pillow Blocks
 7. Super Precision Bearings
 8. Linear Motion
 9. Rolling Mill Bearings
 10. Engineering information, for all bearing types, is in section 9.

If you are still unable to identify the bearing you need, call your NSK Distribution Center.

Things You Should Know About NSK...

NSK is a world-class producer of ball and roller bearings. Established in 1916, NSK became one of the leaders in the bearing industry because of an intense commitment to engineering research, dedication to modern manufacturing processes and an obsession for quality.

Our worldwide network of modern manufacturing facilities and distribution centers is linked by an elaborate computer network that gives us the ability to provide fast service and delivery to our customers.

Our innovative engineering methods give us the flexibility to keep pace with the ever-changing technical needs of our customers. As a result, we produce bearings designed to operate at higher speeds, with greater precision and greater durability.

NSK has more than 85 years experience in the design, development and manufacture of nearly every kind of anti-friction bearing. This experience combined with up-to-date research methods and close attention to quality control have made NSK a world-class supplier of bearings to all the major industries.

ABOUT THIS CATALOG

We have prepared this catalog to provide you with an accurate, easy-to-use tool for selecting or replacing bearings.

This catalog contains dimensions, tolerances and load ratings for commonly used bearings. It also contains engineering information describing how to fit bearings for housings and shafts, and other features of the various types of bearings.

We have tried to make this catalog as helpful as possible. It is a general purpose “user’s” catalog and will probably provide all the information you need. However, no catalog can include all the factors necessary for all combinations of bearing selection or application. Call us whenever you need more information.

ABOUT BEARINGS, BEARING LIFE, AND ENGINEERING

Bearings - Rolling bearings (as opposed to plain bearings which have no rolling elements) use balls or other rolling elements, located between bearing rings, to minimize friction. The rolling elements are separated and held in position by “cages” or other retaining devices.

Depending on the shape of their rolling elements, bearings fall into two main classes – ball bearings and roller bearings. Bearings are further classified by the specific shape of their rolling elements as ball, cylindrical, spherical, tapered.

Bearings are also classified by function. For example, they can be classified as “radial,” “thrust” or both, depending on the direction of the applied load.

Bearing Life - Many factors affect the life of rolling bearings. These include assembly and mounting practices, preloading, lubrication, alignment and exposure to contamination or moisture. Adverse conditions in any of these areas may cause bearing failure. However, if precautions are taken to eliminate these potential trouble spots, the ultimate life of the bearing will be quite predictable. Detailed information about bearing life is provided in the Engineering Section of this catalog.

Bearing Engineering - Bearing engineering ranges from research engineering to design engineering to application engineering. The Engineering Section in this catalog is presented as a useful guide for bearing selection and application. The topics covered within this section include:

- Bearing Selection
- Bearing Identification
- Bearing Clearances
- Bearing Tolerances
- Shaft and Housing Fits
- Bearing Preloads
- Bearing Lubrication Methods and Materials

If you need additional information, please contact your NSK Distribution Center for help.

About Warranty and Liability

Conditions of Sale – All products described in this catalog are subject to NSK’s Distributor Policy Terms and Conditions.

NSK has no responsibility for loss or damage occasioned by delay in delivery, whether such delay is caused by our own acts, our agents or otherwise. In addition, NSK will not be liable for loss or damage arising from circumstance beyond our control, such as “acts of God,” fires, accidents, strikes, lockouts or any similar cause.

Warranty - NSK prides itself on its close attention to the smallest details of product quality and NSK products are warranted to be free from defects in materials and workmanship. Our obligation under this warranty is limited to replacing any NSK products which prove to be defective within one year from the date of purchase, and which NSK is notified of within one (1) year from the date of delivery.

Replacement of bearings under this warranty because of application failure will also be considered, provided the application of the product was approved by us and our inspection discloses that the product has been properly mounted, housed, lubricated and not subject to abuse.

To receive credit or replacement, claim for defective material or workmanship must be verified by an authorized representative of NSK Corporation, and all products subject to claim must be delivered to the designated destination, transportation charges prepaid. NSK specifically disclaims any implied warranties or merchantability and/or fitness for a particular purpose.

Warning - NSK bearings are precision products. Any misuse, and/or misapplication may result in property damage and/or serious personal injury. For proper use and application refer to this catalog or consult NSK for engineering assistance.

Other Product Capabilities

NSK is a world leader in motion and control technology. With manufacturing facilities in the United States, Europe, Japan and South America, NSK produces many different types and sizes of ball and roller bearings — over 100,000 configurations in all — as well as related products, such as ball screws, linear guides, and various automotive subassemblies.

From miniature bearings no larger than the head of a match to giant slewing ring bearings with outside diameters in excess of 16 feet, NSK products are designed for high accuracy, rugged dependability, and minimum maintenance. From bearings for aircraft engines and machine tools, to “sealed-clean” bearings for automobiles and rolling mills, to bearings for computers and home appliances, NSK delivers quality the world over.

This catalog provides information on just a few of the vast array of products available from NSK. For information on the following bearings not included, please contact one of your nearby NSK representatives.

- Linear Guides
- Miniature and Instrument Bearings
- Disk Drive Spindle Bearings
- Railroad Journal (AP) Bearings
- Cylindrical and Tapered Thrust
- Split Water Cooled Plummer Blocks
- Four Point Angular Contact Bearings
- Automotive Transmission Bearings
- Slewing Ring Bearings
- One Way Clutches
- Extra Thin Ball Bearings
- Bearing Monitors
- Tension Leveler Bearings
- Magneto Bearings
- Wheel Hub Bearings
- And Much More...

Table of Contents

Ball Bearings

Introduction
Ball Bearings
Cylindrical Roller Bearings
Spherical Roller Bearings
Tapered Roller Bearings
Thrust Bearings
Split Pillow Blocks
Super Precision Bearings
Linear Motion
Rolling Mill Bearings
Engineering Section

INTRODUCTION

About NSK Ball Bearings7

NOMENCLATURE/INTERCHANGE

Single Row Deep Groove Nomenclature . . .8

Single Row Deep Groove Interchange8

Angular Contact Nomenclature9

Angular Contact Interchange9

Double Row Nomenclature10

Double Row Interchange10

APPLICATION

Single Row Deep Groove11

Angular Contact11

Double Row11

BEARING TABLES

Series R12

Series 60013

Series 600014

Series 620016

Series 630018

Series 680020

Series 690022

Series 6320024

Series 6330025

Series 1200/130026

Series 2200/230028

Series 3200/330030

Series 5200/530032

Series 720036

Series 730038

Series 740040

Series BL 200/30042

Special Ball Bearings44

Integral Shaft Bearings45

Mast Guide Bearings46

Introduction

ABOUT NSK BALL BEARINGS

- Radial Ball Bearings
- Angular Contact Bearings
- Double Row Bearings
- Self-Aligning Ball Bearings
- Maximum Capacity Bearings
- Mast Guide Bearings
- Integral Shaft Bearings
- Special Bearings

NSK ball bearings can be categorized as Deep Groove Bearings or Angular Contact Bearings. Deep groove bearings are further identified as single or double row, and Conrad type or filling slot type. Specific characteristics of each type are identified by the bearing number.

Radial ball bearings will accommodate moderate to heavy radial loads and low to moderate thrust loads in either direction.

Deep groove radial bearings are manufactured as open type bearings for oil or grease lubrication. They are also available with metal shields and/or seals for use where moderate contamination is present in the operation.

Angular contact bearings are single row types used where radial and thrust loads are combined in the same application. They provide sufficient internal clearances to assume a specific contact angle under thrust loading and are available with angles of 15°, 30° and 40°.

Double row bearings are manufactured both as filling slot and Conrad types, in light and medium series. The filling slot type has higher load capacity but the Conrad type provides a quieter operation and should be used when noise is a consideration.

Self-Aligning bearings are manufactured with two rows of balls and one continuous spherical raceway in the outer ring. This allows for limited misalignment of the shaft and housing.

Maximum capacity bearings are filling slot type bearings used in applications involving heavy radial loads and low speeds where thrust loads are comparatively low. They incorporate filling slots in the inner and outer rings so they can be loaded with additional balls for greater capacity.

Mast Guide bearings are bearings with a high load capacity, specially designed for use in fork lift trucks. These bearings are similar to single row or double row deep groove bearings but the outer race has a very thick cross-section which performs as a wheel or tire. Mast guide bearings can withstand heavy radial loads and occasional thrust loads. Mounted on the fork carriage they provide smooth action as the forks are raised and lowered.

Integral shaft bearings include a shaft with bearing races machined on its O.D. The outer bearing ring, cage and rolling elements are mounted directly on the shaft and an inner ring is not required. These are commonly referred to as water pump bearings since that is a major application for them.

Special bearings include Inch Series bearings, bearings made specifically for automotive air compressor applications and bearings made with special bore, width, or O.D.

Nomenclature — Single Row Deep Groove Ball Bearings

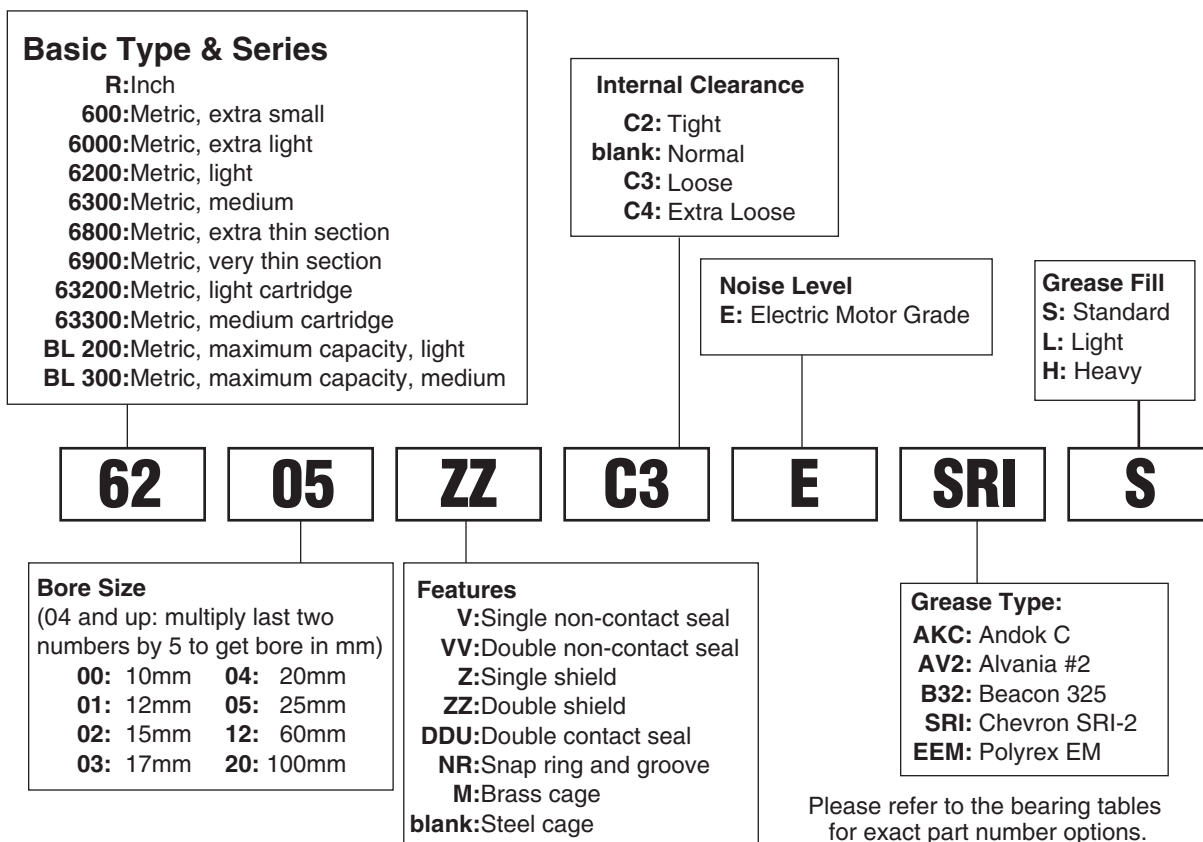

Interchange — Single Row Deep Groove Ball Bearings

DESCRIPTION		INTERCHANGE				
		NSK	SKF	TORR/FAF	FAG	MRC
Part Number	INCH	Rxx	Rxx	Sxx	Rxx	Rxx
	EXTRA SMALL	6xx	6xx	3x	6xx	3x
	EXTRA LIGHT	60xx	60xx	91xxK	60xx	1xxK
	LIGHT	62xx	62xx	2xx	62xx	2xxS
	MEDIUM	63xx	63xx	3xx	63xx	3xxS
	EXTRA THIN SECTION	68xx	618xx	--	618xx	--
	VERY THIN SECTION	69xx	619xx	93xxK	619xx	--
	THIN SECTION	16xxx	16xxx	--	16xxx	--
	MAXIMUM CAPACITY, LIGHT	BL2xx	2xx	2xxW	2xx	2xxM
	MAXIMUM CAPACITY, MEDIUM	BL3xx	3xx	3xxW	3xx	3xxM
Part Number Suffix	TWO SEALS (NON CONTACT)	VV	--	--	--	--
	TWO SEALS (CONTACT)	DDU	2RS	PP	2RSR	ZZ
	ONE SEAL (CONTACT)	DU	RS	P	RSR	Z
	TWO SHIELDS	ZZ	2Z	DD	2ZR	FF
	ONE SHIELD	Z	Z	D	ZR	F
	SNAP RING	NR	NR	G	NR	G
	STEEL CAGE	BLANK	J	BLANK	BLANK	BLANK
	BRASS CAGE	M	M	MBR	M	BRZ
	HEAT STABILIZED 200C	X28	S1	--	S1	--
	TIGHT CLEARANCE	C2	C2	H	C2	Tight
	NORMAL CLEARANCE	BLANK	BLANK	R	BLANK	Normal
	LOOSE CLEARANCE	C3	EM(C3)	P	C3	Loose
	EXTRA LOOSE CLEARANCE	C4	C4	J	C4	Extra Loose
ELECTRIC MOTOR GRADE	E	QE6	--	--	--	

The competitive manufacturers are provided for a convenient source of unit substitution. They can be considered interchangeable in most instances, but for special applications, please consult NSK Engineering. NSK assumes no liability with respect to errors or omissions.

Nomenclature — Angular Contact Ball Bearings (ABEC 1&3)

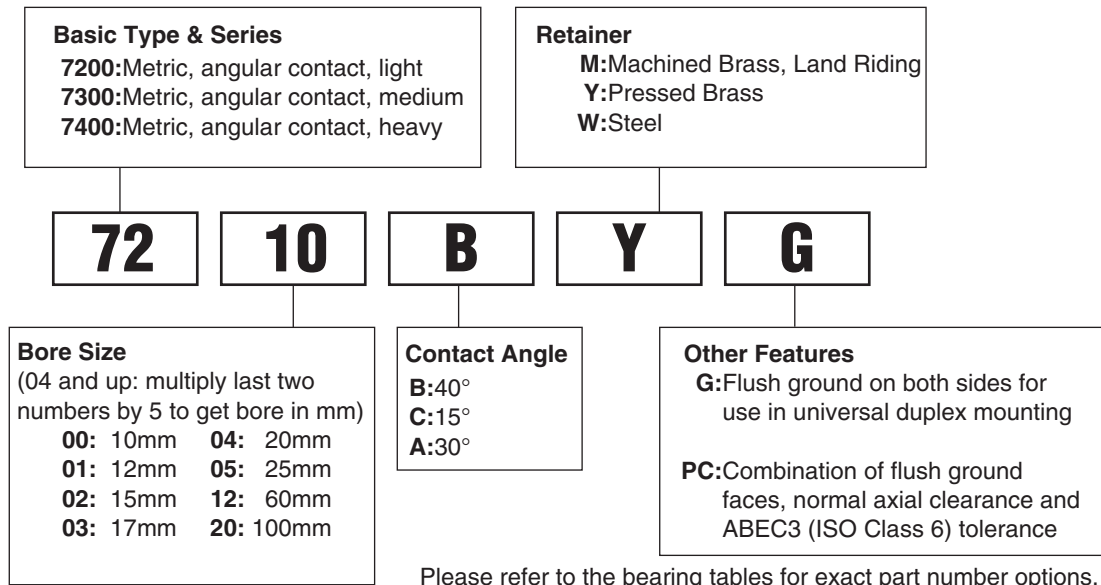

Interchange — Angular Contact Ball Bearings (ABEC 1&3)

DESCRIPTION		INTERCHANGE				
		NSK	SKF	TORR/FAF	FAG	MRC
Part No.	LIGHT	72xx	72xx	72xx	72xx	72xx
	MEDIUM	73xx	73xx	73xx	73xx	73xx
	HEAVY	74xx	74xx	74xx	74xx	74xx
Part No. Suffix	40 deg. CONTACT	B	B	WN	B	PJ
	30 deg. CONTACT	A	--	--	--	BLANK
	25 deg. CONTACT	A5	ACD	--	E	--
	15 deg. CONTACT	C	CD	--	C	R
	MACHINED BRASS CAGE	M	M	MBR	MP	BRZ
	PRESSED BRASS CAGE	Y	Y	BLANK	YP	--
	POLYAMIDE CAGE	TY	P	PRC	TVP	BKE
	STEEL CAGE	W	J	--	JP	BLANK
	FLUSH GROUND FACES	G	G	BLANK	UO,UA	DU
PETROCHEMICAL	BMPC	BECBM	--	--	PumpPac*	

The competitive manufacturers are provided for a convenient source of unit substitution. They can be considered interchangeable in most instances, but for special applications, please consult NSK Engineering. NSK assumes no liability with respect to errors or omissions. *PumpPac is a registered trademark of SKF USA.

Nomenclature — Double Row Ball Bearings

Introduction
Ball Bearings
Cylindrical Roller Bearings
Spherical Roller Bearings
Tapered Roller Bearings
Thrust Bearings
Split Pillow Blocks
Super Precision Bearings
Linear Motion
Rolling Mill Bearings
Engineering Section

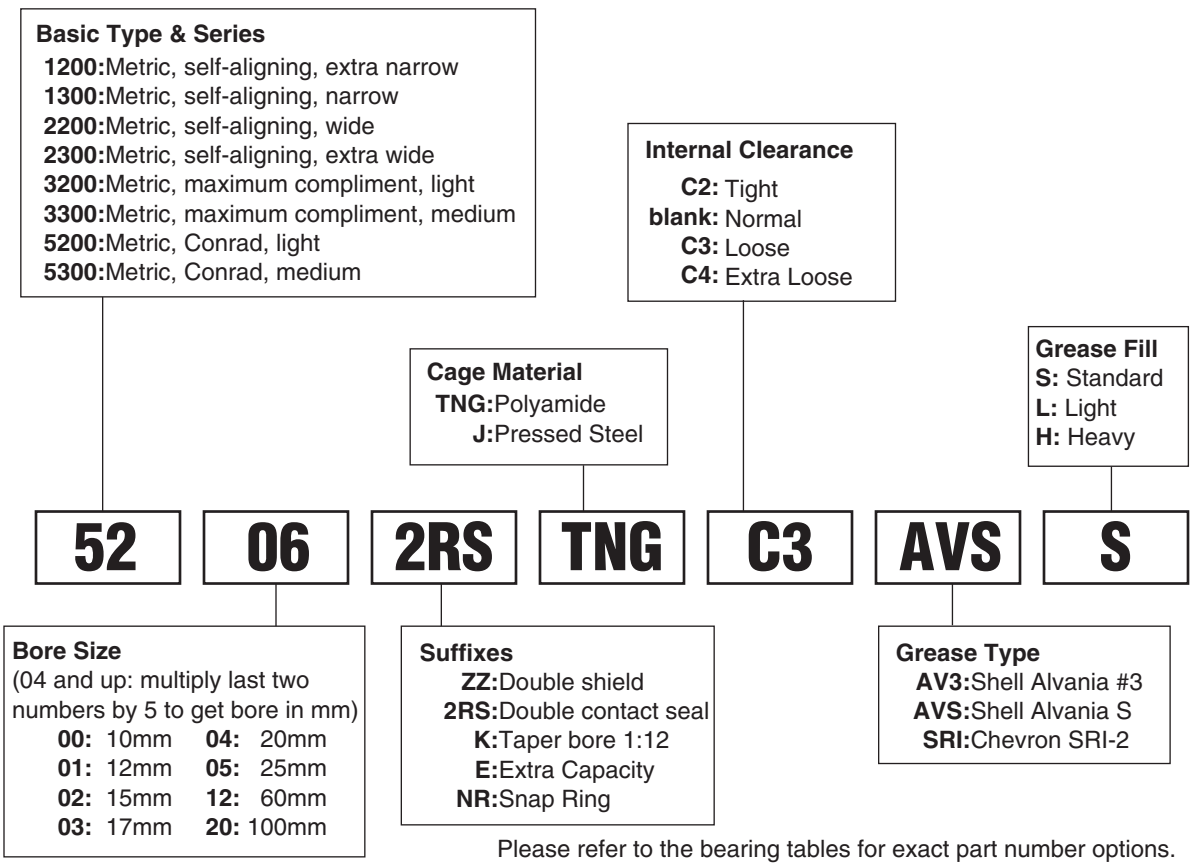

Interchange — Double Row Ball Bearings

DESCRIPTION		INTERCHANGE			
		NSK	SKF	TORR/FAF	MRC
Part Number	SELF-ALIGNING, EXTRA NARROW	12xx	12xx	--	--
	SELF-ALIGNING, NARROW	13xx	13xx	--	--
	SELF-ALIGNING, WIDE	22xx	22xx	--	--
	SELF-ALIGNING, EXTRA WIDE	23xx	23xx	--	--
	DOUBLE ROW, MAXIMUM CAPACITY, LIGHT	32xx	52xxE	52xxW	52xxM (K)
	DOUBLE ROW, MAXIMUM CAPACITY, MEDIUM	33xx	53xxE	53xxW	53xxM (K)
	DOUBLE ROW, CONRAD, LIGHT	52xx	52xxA	52xxK	52xxC (SBK)
DOUBLE ROW, CONRAD, MEDIUM	53xx	53xxA	53xxK	53xxC (SB)	
Part Number Suffix	TWO SEALS	2RS	2RS1	--	--
	TWO SHIELDS	ZZ	2Z	--	FF
	SNAP RING	NR	NR	G	G
	POLYAMIDE CAGE	TNG	TN9	PRB	--
	STEEL CAGE	J	BLANK	BLANK	BLANK
	TAPERED BORE	K	K	--	--
	EXTRA CAPACITY	E	E	--	--
	TIGHT CLEARANCE	C2	C2	H	C2
	NORMAL CLEARANCE	BLANK	BLANK	R	BLANK
	LOOSE CLEARANCE	C3	C3	P	C3
	EXTRA LOOSE CLEARANCE	C4	C4	J	C4

The competitive manufacturers are provided for a convenient source of unit substitution. They can be considered interchangeable in most instances, but for special applications, please consult NSK Engineering. NSK assumes no liability with respect to errors or omissions.

Ball Bearing Applications

General ball bearing applications are listed below. The size and style of the bearing is dependent on the loads applied and the speeds that the application requires. When appropriate, the bearing style will be indicated in parenthesis for an exclusive application, but for most applications listed, a variety of ball bearing styles may be used.

Deep Groove Ball Bearings

- *Transmissions*
- *Electric Motors & Generators*
- *Electrical Appliances*
- *Pumps & Compressors*
- *Blowers & Fans*
- *Speed Changers*
- *Gear Boxes & Drives*
- *Woodworking Machinery*
- *Lawn & Garden Equipment*
- *Turbines*
- *Farm Machinery*
- *Construction Machinery*
- *Oil Field Machinery*
- *Elevators*
- *Conveying Equipment*
- *Hoists & Cranes*
- *Power Hand Tools*
- *Industrial Valves*
- *Rolling Mill Machinery*
- *Textile Machinery*
- *Paper Machinery*
- *Printing Machinery*
- *Food Products Machinery*
- *Packaging Machinery*
- *Medical & Dental Equipment*
(Extra Small)
- *Robotics Equipment (Thin)*
- *Industrial Clutches*
- *Slip Joints*
- *Skate Boards (608ZZ)*
- *Inline Skates (608ZZ)*

Angular Contact (Standard)

- *Metal Rolling Mills*
- *Oil Field Equipment*
- *Gear Boxes & Drives*
- *Deep Well Pumps*
- *Centrifugal Pumps*
- *Electric Motors & Generators*
- *Blowers and Fans*
- *Gear Reducers*

Double Row

- *Petrochemical Equipment*
- *Centrifugal Pumps (Conrad)*
- *Electric Motors (Conrad)*
- *Transmissions*
- *Worm Drives*
- *Blowers & Fans*
- *Film Processing Equipment*
(Self-Aligning)
- *Vertical Spinning Equipment*
(Self-Aligning)
- *Vertical Weaving Equipment*
(Self-Aligning)
- *Paper Making – Fourdrinier*
(Self-Aligning)
- *Industrial Countershafts*
(Self-Aligning)

Ball Bearings

R Series
Single Row, Inch Dimension

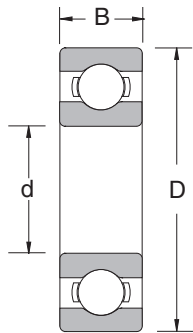

Common Options	
V	: One Non-Contact Seal
VV	: Two Non-Contact Seals
Z	: One Shield
ZZ	: Two Shields
NR	: Snap Ring
CO†	: Normal Clearance
C3	: Looser than Normal
E	: Electric Motor Quality
† Not shown in part number	

Bearing Number	Nominal Bearing Dimensions			Preferred Shoulder Diameters			Basic Load Ratings (lbs)		Limiting Speeds (1000 RPM)	Bearing Weight (Approx.)
	<i>d</i>	<i>D</i>	<i>B</i>	<i>r</i> *	Shaft	Housing	<i>C_r</i>	<i>C_{or}</i>	Grease	lbs
	inch	inch	inch	inch	inch	inch				
R2	0.1250	0.3750	0.1562	0.012	0.188	0.313	141	49	56	0.003
R2A	0.1250	0.5000	0.1719	0.012	0.188	0.438	143	51	56	0.006
R3	0.1875	0.5000	0.1562	0.012	0.250	0.438	293	108	53	0.005
R3ZZ	0.1875	0.5000	0.1960	0.012	0.250	0.438	293	108	53	0.006
R4B	0.2500	0.6250	0.1960	0.012	0.313	0.563	362	150	38	0.010
R4AA	0.2500	0.7500	0.2188	0.016	0.344	0.656	589	238	36	0.015
R4AAZZ	0.2500	0.7500	0.2812	0.016	0.344	0.656	589	238	36	0.018
R6	0.3750	0.8750	0.2188	0.016	0.469	0.781	750	317	38	0.020
R6ZZVV	0.3750	0.8750	0.2812	0.016	0.469	0.781	750	317	38	0.026
R8	0.5000	1.1250	0.2500	0.016	0.594	1.031	1150	538	30	0.040
R8ZZVV	0.5000	1.1250	0.3125	0.016	0.594	1.031	1150	538	30	0.050
R10	0.6250	1.3750	0.2812	0.031	0.750	1.250	1340	728	24	0.060
R10ZZVV	0.6250	1.3750	0.3438	0.031	0.750	1.250	1340	728	24	0.070
R12	0.7500	1.6250	0.3125	0.031	0.906	1.469	2110	1120	20	0.100
R12ZZVV	0.7500	1.6250	0.4375	0.031	0.906	1.469	2110	1120	20	0.120
R14	0.8750	1.8750	0.3750	0.031	1.031	1.719	2270	1310	18	0.160
R14ZZ	0.8750	1.8750	0.5000	0.031	1.031	1.719	2270	1310	18	0.180
R16	1.0000	2.0000	0.3750	0.031	1.156	1.844	2270	1310	18	0.170
R16ZZ	1.0000	2.0000	0.5000	0.031	1.156	1.844	2270	1310	18	0.190
R18	1.1250	2.1250	0.3750	0.031	1.281	1.969	2980	1860	15	0.190
R18ZZ	1.1250	2.1250	0.5000	0.031	1.281	1.969	2980	1860	15	0.210
R20	1.2500	2.2500	0.3750	0.031	1.406	2.094	2980	1860	15	0.210
R20ZZ	1.2500	2.2500	0.5000	0.031	1.406	2.094	2980	1860	15	0.230
R22	1.3750	2.5000	0.4375	0.031	1.531	2.344	3590	2320	13	0.270
R22ZZ	1.3750	2.5000	0.5625	0.031	1.531	2.344	3590	2320	13	0.290
R24	1.5000	2.6250	0.4375	0.031	1.656	2.469	3770	2600	12	0.300

*Maximum fillet which corner radius of bearing will clear.

C_r = Dynamic Radial Load Rating
C_{or} = Static Radial Load Rating

Note: Limiting speeds are lower with contact seals. For more information, contact NSK Engineering.

Application Data	
Radial Internal Clearance	— Table 10.35 page 330
Bearing Tolerances	— Table 10.12 thru Table 10.16 pages 314-17
Snap Ring Dimensions	— Table 10.9 page 310
Shaft & Housing Fits	— Table 10.31 and Table 10.33 pages 328-29

Ball Bearings

600 Series
Single Row, Extra Small

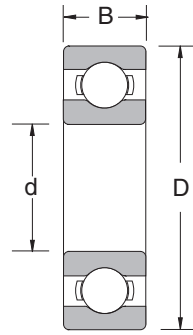

V	: One Non-Contact Seal
VV	: Two Non-Contact Seals
Z	: One Shield
ZZ	: Two Shields
MC3	: Normal Clearance
MC5	: Equivalent to ISO C3
E	: Electric Motor Quality

Bearing Number	Nominal Bearing Dimensions						Preferred Shoulder Diameters			Basic Load Ratings (lbs)		Limiting Speeds (1000 RPM)		lbs
	d		D		B		r*	Shaft	Housing	C _r	C _{or}	Grease	Oil	
	mm	inch	mm	inch	mm	inch	inch	inch	inch					
693	3.00	0.1181	8	0.3150	3.00	0.1181	0.006	0.169	0.287	126	40	60.0	67.0	0.001
693ZZVV	3.00	0.1181	8	0.3150	4.00	0.1575	0.006	0.165	0.268	126	40	60.0	67.0	0.002
623	3.00	0.1181	10	0.3937	4.00	0.1575	0.006	0.165	0.346	141	49	50.0	60.0	0.003
684	4.00	0.1575	9	0.3543	2.50	0.0984	0.004	0.205	0.319	143	51	53.0	63.0	0.001
684ZZVV	4.00	0.1575	9	0.3543	4.00	0.1575	0.004	0.189	0.323	143	51	53.0	63.0	0.002
694	4.00	0.1575	11	0.4331	4.00	0.1575	0.006	0.205	0.386	216	77	48.0	56.0	0.003
604	4.00	0.1575	12	0.4724	4.00	0.1575	0.008	0.220	0.409	216	77	48.0	56.0	0.004
624	4.00	0.1575	13	0.5118	5.00	0.1969	0.008	0.220	0.449	293	108	40.0	48.0	0.006
634	4.00	0.1575	16	0.6299	5.00	0.1969	0.012	0.236	0.551	390	151	36.0	43.0	0.015
685	5.00	0.1969	11	0.4331	3.00	0.1181	0.006	0.244	0.390	161	64	45.0	53.0	0.002
685ZZVV	5.00	0.1969	11	0.4331	5.00	0.1969	0.006	0.244	0.386	161	64	45.0	53.0	0.004
695	5.00	0.1969	13	0.5118	4.00	0.1575	0.008	0.260	0.449	243	97	43.0	50.0	0.005
605	5.00	0.1969	14	0.5512	5.00	0.1969	0.008	0.260	0.488	298	115	40.0	50.0	0.007
625	5.00	0.1969	16	0.6299	5.00	0.1969	0.012	0.276	0.551	390	150	36.0	43.0	0.010
635	5.00	0.1969	19	0.7480	6.00	0.2362	0.012	0.276	0.669	526	199	32.0	40.0	0.022
686	6.00	0.2362	13	0.5118	3.50	0.1378	0.006	0.291	0.461	243	99	40.0	50.0	0.004
686ZZVV	6.00	0.2362	13	0.5118	5.00	0.1969	0.006	0.283	0.465	243	99	40.0	50.0	0.005
696	6.00	0.2362	15	0.5906	5.00	0.1969	0.008	0.299	0.528	390	150	40.0	45.0	0.008
606	6.00	0.2362	17	0.6693	6.00	0.2362	0.012	0.315	0.591	509	187	38.0	45.0	0.012
626	6.00	0.2362	19	0.7480	6.00	0.2362	0.012	0.315	0.669	526	199	32.0	40.0	0.021
687	7.00	0.2756	14	0.5512	3.50	0.1378	0.006	0.335	0.500	265	115	40.0	45.0	0.004
687ZZVV	7.00	0.2756	14	0.5512	5.00	0.1969	0.006	0.323	0.504	265	115	40.0	45.0	0.006
697	7.00	0.2756	17	0.6693	5.00	0.1969	0.012	0.354	0.591	362	161	36.0	43.0	0.011
607	7.00	0.2756	19	0.7480	6.00	0.2362	0.012	0.354	0.669	525	198	36.0	43.0	0.015
627	7.00	0.2756	22	0.8661	7.00	0.2756	0.012	0.354	0.787	741	308	30.0	36.0	0.031
608-5	7.90	0.3123	22	0.8661	7.00	0.2756	0.012	0.394	0.787	741	308	34.0	40.0	0.030
698	8.00	0.3150	19	0.7480	6.00	0.2362	0.012	0.394	0.650	503	205	36.0	43.0	0.014
608	8.00	0.3150	22	0.8661	7.00	0.2756	0.012	0.394	0.787	741	308	34.0	40.0	0.030
628	8.00	0.3150	24	0.9449	8.00	0.3150	0.012	0.394	0.669	750	322	28.0	34.0	0.034
638	8.00	0.3150	28	1.1024	9.00	0.3543	0.012	0.394	1.024	1030	443	28.0	34.0	0.057
689	9.00	0.3543	17	0.6693	4.00	0.1575	0.008	0.421	0.598	300	150	36.0	43.0	0.007
689ZZVV	9.00	0.3543	17	0.6693	5.00	0.1969	0.008	0.417	0.606	300	150	36.0	43.0	0.009
609	9.00	0.3543	24	0.9449	7.00	0.2756	0.012	0.433	0.866	750	322	32.0	38.0	0.029
629	9.00	0.3543	26	1.0236	8.00	0.3150	0.024	0.453	0.945	1030	444	28.0	34.0	0.044

*Maximum fillet which corner radius of bearing will clear.

C_r = Dynamic Radial Load Rating
C_{or} = Static Radial Load Rating

Note: Limiting speeds are lower with contact seals. For more information, contact NSK Engineering.

Application Data	
Radial Internal Clearance	— Table 10.35 on page 330
Bearing Tolerances	— Table 10.12 thru Table 10.16 on pages 314-17
Shaft & Housing Fits	— Table 10.31 and Table 10.33 on pages 328-29

Introduction

Ball Bearings

Cylindrical Roller Bearings

Spherical Roller Bearings

Tapered Roller Bearings

Thrust Bearings

Split Pillow Blocks

Super Precision Bearings

Linear Motion

Rolling Mill Bearings

Engineering Section



Ball Bearings

6000 Series
Single Row, Deep Groove, Conrad Type

Bearing Number	Nominal Bearing Dimensions						Preferred Shoulder Diameters			
	<i>d</i>		<i>D</i>		<i>B</i>		<i>r</i> *	<i>da</i> (in)		<i>Da</i> (in)
	mm	inch	mm	inch	mm	inch	inch	min	max	max
6000	10	0.3937	26	1.0236	8	0.3150	0.012	0.472	0.512	0.949
6001	12	0.4724	28	1.1024	8	0.3150	0.012	0.551	0.611	1.024
6002	15	0.5906	32	1.2598	9	0.3543	0.012	0.669	0.749	1.181
6003	17	0.6693	35	1.3780	10	0.3937	0.012	0.748	0.847	1.299
6004	20	0.7874	42	1.6535	12	0.4724	0.024	0.945	1.005	1.496
6005	25	0.9843	47	1.8504	12	0.4724	0.024	1.142	1.182	1.693
6006	30	1.1811	55	2.1654	13	0.5118	0.039	1.378	1.438	1.969
6007	35	1.3780	62	2.4409	14	0.5512	0.039	1.575	1.635	2.244
6008	40	1.5748	68	2.6772	15	0.5906	0.039	1.772	1.872	2.480
6009	45	1.7717	75	2.9528	16	0.6299	0.039	1.969	2.108	2.756
6010	50	1.9685	80	3.1496	16	0.6299	0.039	2.165	2.305	2.953
6011	55	2.1654	90	3.5433	18	0.7087	0.039	2.421	2.528	3.287
6012	60	2.3622	95	3.7402	18	0.7087	0.039	2.618	2.719	3.484
6013	65	2.5591	100	3.9370	18	0.7087	0.039	2.815	2.876	3.681
6014	70	2.7559	110	4.3307	20	0.7874	0.039	3.012	3.172	4.075
6015	75	2.9528	115	4.5276	20	0.7874	0.039	3.209	3.369	4.272
6016	80	3.1496	125	4.9213	22	0.8661	0.039	3.406	3.585	4.665
6017	85	3.3465	130	5.1181	22	0.8661	0.039	3.602	3.782	4.862
6018	90	3.5433	140	5.5118	24	0.9449	0.059	3.858	4.058	5.197
6019	95	3.7402	145	5.7087	24	0.9449	0.059	4.055	4.275	5.394
6020	100	3.9370	150	5.9055	24	0.9449	0.059	4.252	4.452	5.591
6021	105	4.1339	160	6.2992	26	1.0236	0.079	4.528	4.728	5.906
6022	110	4.3307	170	6.6929	28	1.1024	0.079	4.724	4.905	6.299
6024	120	4.7244	180	7.0866	28	1.1024	0.079	5.118	5.299	6.693
6026	130	5.1181	200	7.8740	33	1.2992	0.079	5.512	5.851	7.480
6028	140	5.5118	210	8.2677	33	1.2992	0.079	5.906	6.245	7.874
6030	150	5.9055	225	8.8583	35	1.3780	0.079	6.339	6.698	8.425
6032	160	6.2992	240	9.4488	38	1.4961	0.079	6.732	7.131	9.016
6034	170	6.6929	260	10.2362	42	1.6535	0.079	7.126	7.663	9.803
6036	180	7.0866	280	11.0236	46	1.8110	0.079	7.520	8.195	10.591
6038	190	7.4803	290	11.4173	46	1.8110	0.079	7.913	8.589	10.984
6040	200	7.8740	310	12.2047	51	2.0079	0.079	8.307	9.121	11.772

*Maximum fillet which corner radius of bearing will clear.

Note: Limiting speeds are lower with contact seals. For more information, contact NSK Engineering.

Application Data

Radial Internal Clearance — Table 10.35 page 330
 Bearing Tolerances — Table 10.12 thru Table 10.16 pages 314-17
 Snap Ring Dimensions — Table 10.9 page 310
 Shaft & Housing Fits — Table 10.31 and Table 10.33 pages 328-29

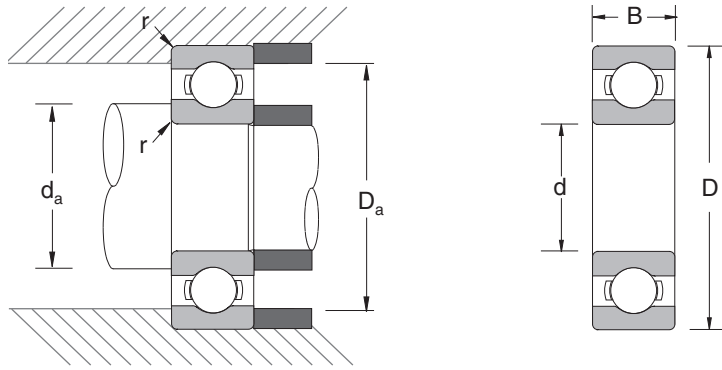

Common Options	
V	: One Non-Contact Seal
VV	: Two Non-Contact Seals
Z	: One Shield
ZZ	: Two Shields
DU	: One Contact Seal
DDU	: Two Contact Seals
NR	: Snap Ring
M††	: Brass Cage
CO†	: Normal Internal Clearance
C3	: Greater Than Normal
E	: Electric Motor Quality

† Not shown in part number
 †† Not available on small sizes.
 Consult NSK for availability.

Bearing Number	Basic Load Ratings (lbs)		Factor f_o	Limiting Speeds (1000 RPM)		Bearing Weight (Approx.) lbs
	C_r	C_{or}		Grease	Oil	
6000	1030	443	12.4	30.0	36.0	0.04
6001	1150	531	13.0	28.0	32.0	0.05
6002	1260	637	13.9	24.0	28.0	0.07
6003	1350	732	14.4	22.0	26.0	0.09
6004	2110	1130	13.8	18.0	20.0	0.16
6005	2270	1310	14.5	15.0	18.0	0.18
6006	2980	1860	14.7	13.0	15.0	0.26
6007	3590	2315	14.8	11.0	13.0	0.35
6008	3770	2600	15.3	10.0	12.0	0.43
6009	4720	3420	15.3	9.0	11.0	0.54
6010	4900	3750	15.6	8.5	10.0	0.58
6011	6350	4780	15.3	7.5	9.0	0.85
6012	6610	5230	15.6	7.1	8.5	0.92
6013	6880	5670	15.8	6.7	8.0	0.96
6014	8550	6970	15.6	6.0	7.1	1.33
6015	8890	7540	15.8	5.6	6.7	1.41
6016	11000	8950	15.6	5.3	6.3	1.87
6017	11100	9680	15.8	5.0	6.0	1.96
6018	13100	11200	15.6	4.8	5.6	2.56
6019	13600	12100	15.8	4.5	5.3	2.67
6020	13500	12200	15.9	4.3	5.3	2.76
6021	16300	14800	15.8	4.0	4.8	3.51
6022	19000	16400	15.5	3.8	4.5	4.32
6024	19900	18000	15.7	3.6	4.3	5.34
6026	23800	22700	15.8	3.0	3.6	8.16
6028	24700	24300	16.0	2.8	3.4	8.62
6030	28200	28200	15.9	2.6	3.0	10.60
6032	30600	30400	15.9	2.4	2.8	13.00
6034	36200	36200	15.8	2.2	2.6	17.50
6036	40600	41500	15.6	2.0	2.4	23.00
6038	42300	45200	15.8	2.0	2.4	24.50
6040	46500	50700	15.6	1.9	2.2	31.00

C_r = Dynamic Radial Load Rating
 C_{or} = Static Radial Load Rating Engineering.

Note: Limiting speeds are lower with contact seals. For more information, contact NSK Engineering.



Ball Bearings

6200 Series
Single Row, Deep Groove, Conrad Type

Bearing Number	Nominal Bearing Dimensions						Preferred Shoulder Diameters			
	<i>d</i>		<i>D</i>		<i>B</i>		<i>r</i> *	<i>da</i> (in)		<i>Da</i> (in)
	mm	inch	mm	inch	mm	inch	inch	min	max	max
6200	10	0.3937	30	1.1811	9	0.3543	0.024	0.500	0.630	0.984
6201	12	0.4724	32	1.2598	10	0.3937	0.024	0.578	0.670	1.063
6201-08	12.7	0.5000	32	1.2598	10	0.3937	0.024	0.595	0.670	1.063
6201-13 M	13	0.5118	32	1.2598	10	0.3937	0.024	0.610	0.670	1.063
6202	15	0.5906	35	1.3780	11	0.4331	0.024	0.703	0.749	1.181
6202-10	15.87	0.6250	35	1.3780	11	0.4331	0.024	0.730	0.749	1.181
6202-16 M	16	0.6299	35	1.3780	11	0.4331	0.024	0.740	0.749	1.181
6203	17	0.6693	40	1.5748	12	0.4724	0.024	0.787	0.926	1.380
6203-625	15.9	0.6250	40	1.5748	12	0.4724	0.024	0.750	0.926	1.380
6204	20	0.7874	47	1.8504	14	0.5512	0.039	0.969	1.044	1.614
6205	25	0.9843	52	2.0472	15	0.5906	0.039	1.172	1.261	1.811
6206	30	1.1811	62	2.4409	16	0.6299	0.039	1.406	1.517	2.205
6207	35	1.3780	72	2.8346	17	0.6693	0.039	1.614	1.753	2.559
6208	40	1.5748	80	3.1496	18	0.7087	0.039	1.811	1.990	2.874
6209	45	1.7717	85	3.3465	19	0.7480	0.039	2.008	2.187	3.071
6210	50	1.9685	90	3.5433	20	0.7874	0.039	2.205	2.364	3.268
6211	55	2.1654	100	3.9370	21	0.8268	0.059	2.441	2.620	3.602
6212	60	2.3622	110	4.3307	22	0.8661	0.059	2.717	2.935	3.996
6213	65	2.5591	120	4.7244	23	0.9055	0.059	2.913	3.152	4.390
6214	70	2.7559	125	4.9213	24	0.9449	0.059	3.110	3.310	4.587
6215	75	2.9528	130	5.1181	25	0.9843	0.059	3.307	3.546	4.783
6216	80	3.1496	140	5.5118	26	1.0236	0.079	3.504	3.763	5.118
6217	85	3.3465	150	5.9055	28	1.1024	0.079	3.740	4.019	5.512
6218	90	3.5433	160	6.2992	30	1.1811	0.079	3.937	4.236	5.906
6219	95	3.7402	170	6.6929	32	1.2598	0.079	4.213	4.492	6.220
6220	100	3.9370	180	7.0866	34	1.3386	0.079	4.409	4.787	6.614
6221	105	4.1339	190	7.4803	36	1.4173	0.079	4.606	5.024	7.008
6222	110	4.3307	200	7.8740	38	1.4961	0.079	4.803	5.280	7.402
6224	120	4.7244	215	8.4646	40	1.5748	0.079	5.197	5.752	7.992
6226	130	5.1181	230	9.0551	40	1.5748	0.098	5.669	6.206	8.504
6228	140	5.5118	250	9.8425	42	1.6535	0.098	6.063	6.757	9.291
6230	150	5.9055	270	10.6299	45	1.7717	0.098	6.457	7.328	10.079
6232	160	6.2992	290	11.4173	48	1.8898	0.098	6.850	7.959	10.886
6234	170	6.6929	310	12.2047	52	2.0472	0.118	7.362	8.471	11.535
6236	180	7.0866	320	12.5984	52	2.0472	0.118	7.758	8.786	11.929
6238	190	7.4803	340	13.3858	55	2.1654	0.118	8.150	9.298	12.717

*Maximum fillet which corner radius of bearing will clear.

Note: Limiting speeds are lower with contact seals. For more information, contact NSK Engineering.

Application Data

Bearing Tolerances — Table 10.12 thru Table 10.16 pages 314-17
 Snap Ring Dimensions — Table 10.9 page 310
 Shaft & Housing Fits — Table 10.31 and Table 10.33 pages 328-29

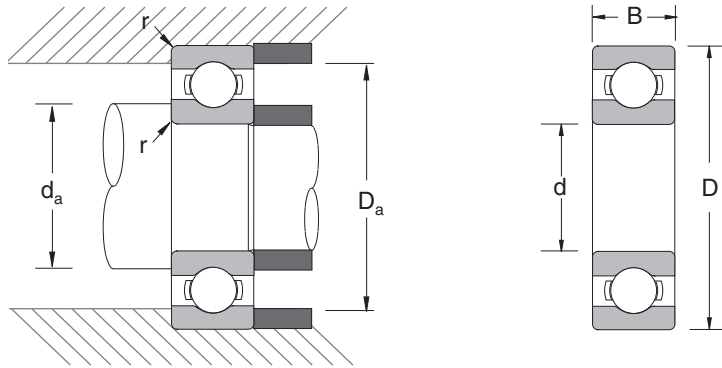

Common Options	
V	: One Non-Contact Seal
VV	: Two Non-Contact Seals
Z	: One Shield
ZZ	: Two Shields
DU	: One Contact Seal
DDU	: Two Contact Seals
NR	: Snap Ring
M††	: Brass Cage
CO†	: Normal Internal Clearance
C3	: Greater Than Normal
E	: Electric Motor Quality
† Not shown in part number	
†† Not available on small sizes, Consult NSK for availability.	

Bearing Number	Basic Load Ratings (lbs)		Factor f_o	Limiting Speeds (1000 RPM)		Bearing Weight (Approx.) lbs
	C_r	C_{or}		Grease	Oil	
6200	1150	538	13.2	24.0	30.0	0.07
6201	1530	685	12.3	22.0	28.0	0.08
6201-08	1530	685	12.3	22.0	28.0	0.08
6201-13 M	1530	685	12.3	22.0	28.0	0.08
6202	1720	839	13.2	20.0	24.0	0.10
6202-10	1720	839	13.2	20.0	24.0	0.10
6202-16 M	1720	839	13.2	20.0	24.0	0.10
6203	2150	1080	13.2	17.0	20.0	0.14
6203-625	2150	1080	13.2	17.0	20.0	0.14
6204	2880	1480	13.1	15.0	18.0	0.23
6205	3150	1770	13.9	13.0	15.0	0.29
6206	4380	2540	13.8	11.0	13.0	0.44
6207	5770	3440	13.8	9.5	11.0	0.64
6208	6550	4010	14.0	8.5	10.0	0.82
6209	7030	4580	14.4	7.5	9.0	0.89
6210	7890	5220	14.4	7.1	8.5	1.02
6211	9760	6580	14.3	6.3	7.5	1.36
6212	11800	8130	14.3	5.6	7.1	1.73
6213	12900	9010	14.4	5.3	6.3	2.18
6214	14000	9910	14.5	5.0	6.3	2.31
6215	14900	11100	14.7	4.8	5.6	2.64
6216	16300	11900	14.6	4.5	5.3	3.09
6217	18900	13900	14.5	4.3	5.0	3.97
6218	21600	16100	14.5	4.0	4.8	4.74
6219	24500	18400	14.4	3.8	4.5	5.73
6220	27500	20900	14.4	3.6	4.3	6.94
6221	29900	23500	14.4	3.4	4.0	8.15
6222	32400	26300	14.3	2.8	3.4	9.59
6224	34900	29500	14.4	2.6	3.2	11.40
6226	37500	32900	14.5	2.4	3.0	12.70
6228	37400	33700	14.9	2.2	2.8	19.60
6230	39600	37700	15.1	2.0	2.6	25.30
6232	41600	41800	15.4	1.9	2.4	28.16
6234	47700	50300	15.3	1.8	2.2	34.32
6236	51100	55000	15.1	1.7	2.0	34.76
6238	57300	63300	15.0	1.6	2.0	48.84

C_r = Dynamic Radial Load Rating
 C_{or} = Static Radial Load Rating Engineering.

Note: Limiting speeds are lower with contact seals. For more information, contact NSK Engineering.



Ball Bearings

6300 Series
Single Row, Deep Groove, Conrad Type

Bearing Number	Nominal Bearing Dimensions						Preferred Shoulder Diameters			
	<i>d</i>		<i>D</i>		<i>B</i>		<i>r</i> *	<i>da</i> (in)		<i>Da</i> (in)
	mm	inch	mm	inch	mm	inch	inch	min	max	max
6300	10	0.3937	35	1.3780	11	0.4331	0.024	0.563	0.650	1.181
6301	12	0.4724	37	1.4567	12	0.4724	0.039	0.656	0.709	1.220
6302	15	0.5906	42	1.6535	13	0.5118	0.039	0.781	0.887	1.417
6303	17	0.6693	47	1.8504	14	0.5512	0.039	0.875	1.005	1.614
6304	20	0.7874	52	2.0472	15	0.5906	0.039	1.016	1.103	1.772
6305	25	0.9843	62	2.4409	17	0.6693	0.039	1.220	1.418	2.165
6306	30	1.1811	72	2.8346	19	0.7480	0.039	1.469	1.675	2.559
6307	35	1.3780	80	3.1496	21	0.8268	0.059	1.688	1.852	2.795
6308	40	1.5748	90	3.5433	23	0.9055	0.059	1.929	2.088	3.189
6309	45	1.7717	100	3.9370	25	0.9843	0.059	2.126	2.423	3.583
6310	50	1.9685	110	4.3307	27	1.0630	0.079	2.362	2.679	3.937
6311	55	2.1654	120	4.7244	29	1.1417	0.079	2.559	2.857	4.331
6312	60	2.3622	130	5.1181	31	1.2205	0.079	2.835	3.113	4.646
6313	65	2.5591	140	5.5118	33	1.2992	0.079	3.031	3.369	5.039
6314	70	2.7559	150	5.9055	35	1.3780	0.079	3.228	3.625	5.433
6315	75	2.9528	160	6.2992	37	1.4567	0.079	3.425	3.881	5.827
6316	80	3.1496	170	6.6929	39	1.5354	0.079	3.622	4.117	6.220
6317	85	3.3465	180	7.0866	41	1.6142	0.098	3.898	4.354	6.535
6318	90	3.5433	190	7.4803	43	1.6929	0.098	4.094	4.610	6.929
6319	95	3.7402	200	7.8740	45	1.7717	0.098	4.291	4.866	7.323
6320	100	3.9370	215	8.4646	47	1.8504	0.098	4.488	5.240	7.913
6321	105	4.1339	225	8.8583	49	1.9291	0.098	4.685	5.437	8.307
6322	110	4.3307	240	9.4488	50	1.9685	0.098	4.882	5.851	8.898
6324	120	4.7244	260	10.2362	55	2.1654	0.098	5.276	6.343	9.685
6326	130	5.1181	280	11.0236	58	2.2835	0.118	5.827	6.895	10.315
6328	140	5.5118	300	11.8110	62	2.4409	0.118	6.220	7.368	11.102
6330	150	5.9055	320	12.5984	65	2.5591	0.118	6.614	7.998	11.890
6332	160	6.2992	340	13.3858	68	2.6772	0.118	7.008	-	12.677
6334	170	6.6929	360	14.1732	72	2.8346	0.118	7.402	-	13.465
6336	180	7.0866	380	14.9606	75	2.9528	0.118	7.795	-	14.252
6338	190	7.4803	400	15.7480	78	3.0709	0.157	8.346	-	14.882
6340	200	7.8740	420	16.5354	80	3.1496	0.157	8.740	-	15.669

*Maximum fillet which corner radius of bearing will clear.

Note: Limiting speeds are lower with contact seals. For more information, contact NSK Engineering.

Application Data

Radial Internal Clearance — Table 10.35 page 330
 Bearing Tolerances — Table 10.12 thru Table 10.16 pages 314-17
 Snap Ring Dimensions — Table 10.9 page 310
 Shaft & Housing Fits — Table 10.31 and Table 10.33 pages 328-29

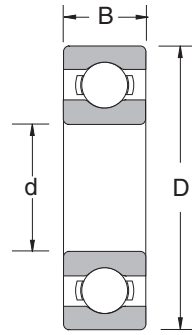
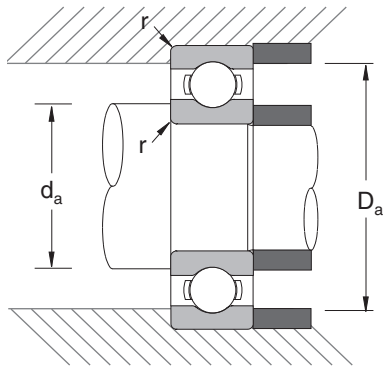

Common Options	
V	: One Non-Contact Seal
VV	: Two Non-Contact Seals
Z	: One Shield
ZZ	: Two Shields
DU	: One Contact Seal
DDU	: Two Contact Seals
NR	: Snap Ring
M††	: Brass Cage
CO†	: Normal Internal Clearance
C3	: Greater Than Normal
E	: Electric Motor Quality

† Not shown in part number
 †† Not available on small sizes,
 Consult NSK for availability.

Bearing Number	Basic Load Ratings (lbs)		Factor f_o	Limiting Speeds (1000 RPM)		Bearing Weight (Approx.) lbs
	C_r	C_{or}		Grease	Oil	
6300	1820	772	11.2	22.0	26.0	0.12
6301	2180	941	11.1	20.0	24.0	0.13
6302	2570	1220	12.3	17.0	20.0	0.18
6303	3060	1490	12.4	15.0	18.0	0.25
6304	3580	1770	12.4	14.0	17.0	0.32
6305	4630	2530	13.2	11.0	13.0	0.52
6306	5990	3380	13.3	9.5	12.0	0.76
6307	7490	4320	13.2	8.5	10.0	1.01
6308	9160	5400	13.2	7.5	9.0	1.40
6309	11900	7210	13.1	6.7	8.0	1.84
6310	13900	8610	13.2	6.0	7.5	2.42
6311	16100	10040	13.1	5.6	6.7	2.98
6312	18400	11680	13.1	5.3	6.3	3.75
6313	20800	13450	13.2	4.8	6.0	4.63
6314	23400	15300	13.2	4.5	5.3	5.51
6315	25500	17400	13.2	4.3	5.0	6.61
6316	27600	19500	13.3	4.0	4.8	7.93
6317	29800	21800	13.3	3.8	4.5	9.37
6318	32100	24100	13.3	3.6	4.3	10.80
6319	34400	26700	13.3	3.0	3.6	12.50
6320	38900	31800	13.2	2.8	3.4	15.30
6321	41300	34500	13.2	2.6	3.2	17.90
6322	46200	40300	13.2	2.4	3.0	21.00
6324	46500	41500	13.5	2.2	2.8	27.60
6326	51600	48200	13.6	2.2	2.6	40.80
6328	56800	55300	13.6	2.0	2.4	48.50
6330	61700	63800	13.9	1.8	2.2	57.30
6332	62400	64400	13.9	1.7	2.0	58.00
6334	73400	79800	13.6	1.6	2.0	84.00
6336	79600	91600	13.9	1.5	1.8	98.00
6338	79700	93200	14.1	1.4	1.7	112.00
6340	85300	100400	13.8	1.3	1.6	127.00

C_r = Dynamic Radial Load Rating
 C_{or} = Static Radial Load Rating Engineering.

Note: Limiting speeds are lower with contact seals. For more information, contact NSK Engineering.



Ball Bearings

6800 Series

Single Row, Deep Groove, Conrad Type

Bearing Number	Nominal Bearing Dimensions						Preferred Shoulder Diameters			
	<i>d</i>		<i>D</i>		<i>B</i>		<i>r</i> *	<i>da</i> (in)		<i>Da</i> (in)
	mm	inch	mm	inch	mm	inch	inch	min	max	max
6800	10	0.3937	19	0.7480	5	0.1969	0.012	0.551	0.551	0.700
6801	12	0.4724	21	0.8268	5	0.1969	0.012	0.551	0.551	0.748
6802	15	0.5906	24	0.9449	5	0.1969	0.012	0.669	0.669	0.866
6803	17	0.6693	26	1.0236	5	0.1969	0.012	0.748	0.748	0.945
6804	20	0.7874	32	1.2598	7	0.2756	0.012	0.866	0.866	1.181
6805	25	0.9843	37	1.4567	7	0.2756	0.012	1.063	1.063	1.378
6806	30	1.1811	42	1.6535	7	0.2756	0.012	1.260	1.260	1.575
6807	35	1.3780	47	1.8504	7	0.2756	0.012	1.457	1.457	1.772
6808	40	1.5748	52	2.0472	7	0.2756	0.012	1.654	1.654	1.969
6809	45	1.7717	58	2.2835	7	0.2756	0.012	1.850	1.870	2.205
6810	50	1.9685	65	2.5591	7	0.2756	0.012	2.047	2.067	2.480
6811	55	2.1654	72	2.8346	9	0.3543	0.012	2.244	2.323	2.756
6812	60	2.3622	78	3.0709	10	0.3937	0.012	2.441	2.520	2.992
6813	65	2.5591	85	3.3465	10	0.3937	0.024	2.717	2.717	3.189
6814	70	2.7559	90	3.5433	10	0.3937	0.024	2.913	2.933	3.386
6815	75	2.9528	95	3.7402	10	0.3937	0.024	3.110	3.130	3.583
6816	80	3.1496	100	3.9370	10	0.3937	0.024	3.307	3.327	3.780
6817	85	3.3465	110	4.3307	13	0.5118	0.039	3.543	3.563	4.134
6818	90	3.5433	115	4.5276	13	0.5118	0.039	3.740	3.760	4.331
6819	95	3.7402	120	4.7244	13	0.5118	0.039	3.937	3.957	4.528
6820	100	3.9370	125	4.9213	13	0.5118	0.039	4.134	4.154	4.724
6821	105	4.1339	130	5.1181	13	0.5118	0.039	4.331	4.350	4.921
6822	110	4.3307	140	5.5118	16	0.6299	0.039	4.528	4.606	5.315
6824	120	4.7244	150	5.9055	16	0.6299	0.039	4.921	5.000	5.709
6826	130	5.1181	165	6.4961	18	0.7087	0.039	5.374	5.433	6.240
6828	140	5.5118	175	6.8898	18	0.7087	0.039	5.768	-	6.634
6830	150	5.9055	190	7.4803	20	0.7874	0.039	6.161	-	7.224
6832	160	6.2992	200	7.8740	20	0.7874	0.039	6.555	6.713	7.618
6834	170	6.6929	215	8.4646	22	0.8661	0.039	6.949	7.165	8.209
6836	180	7.0866	225	8.8583	22	0.8661	0.039	7.343	-	8.602
6838	190	7.4803	240	9.4488	24	0.9449	0.059	7.795	7.972	9.134
6840	200	7.8740	250	9.8425	24	0.9449	0.059	8.189	-	9.528

*Maximum fillet which corner radius of bearing will clear.

Note: Limiting speeds are lower with contact seals. For more information, contact NSK Engineering.

Application Data

Radial Internal Clearance — Table 10.35 page 330
 Bearing Tolerances — Table 10.12 thru Table 10.16 pages 314-17
 Snap Ring Dimensions — Table 10.9 page 310
 Shaft & Housing Fits — Table 10.31 and Table 10.33 pages 328-29

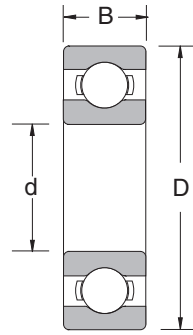
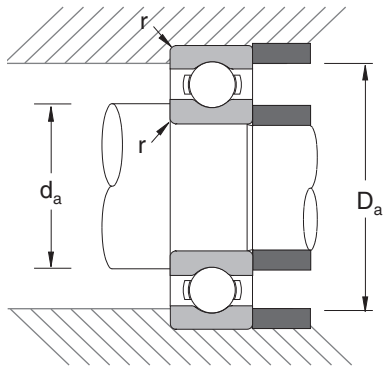

Common Options	
V	: One Non-Contact Seal
VV	: Two Non-Contact Seals
Z	: One Shield
ZZ	: Two Shields
DU	: One Contact Seal
DDU	: Two Contact Seals
NR	: Snap Ring
M††	: Brass Cage
CO†	: Normal Internal Clearance
C3	: Greater Than Normal
E	: Electric Motor Quality

† Not shown in part number
 †† Not available on small sizes,
 Consult NSK for availability.

Bearing Number	Basic Load Ratings (lbs)		Factor f_o	Limiting Speeds (1000 RPM)		Bearing Weight (Approx.) lbs
	C_r	C_{or}		Grease	Oil	
6800	385	189	14.8	34.0	40.0	0.01
6801	429	233	15.3	32.0	38.0	0.01
6802	466	282	15.8	28.0	34.0	0.02
6803	590	352	15.7	26.0	30.0	0.02
6804	902	554	15.5	22.0	26.0	0.04
6805	968	660	16.1	18.0	22.0	0.05
6806	1010	770	16.4	15.0	18.0	0.05
6807	1070	880	16.7	13.0	16.0	0.06
6808	1100	979	17.0	12.0	14.0	0.07
6809	1210	1180	17.2	11.0	13.0	0.08
6810	1440	1400	17.2	9.5	11.0	0.11
6811	1980	1900	17.0	8.5	10.0	0.18
6812	2570	2460	16.9	8.0	9.5	0.22
6813	2680	2710	17.0	7.5	8.5	0.28
6814	2710	2860	17.2	6.7	8.0	0.29
6815	2820	3100	17.3	6.3	7.5	0.32
6816	2840	3230	17.4	6.0	7.4	0.32
6817	4200	4490	17.1	5.6	6.7	0.56
6818	4270	4710	17.2	5.3	6.3	0.59
6819	4330	4930	17.2	5.0	6.0	0.63
6820	4400	5150	17.3	4.8	5.6	0.66
6821	4440	5370	17.4	4.8	5.6	0.69
6822	6290	7370	17.1	4.3	5.3	1.07
6824	6490	8030	17.3	4.0	4.8	1.16
6826	8250	9790	17.1	3.6	4.3	1.63
6828	8580	10700	17.3	3.4	4.0	1.79
6830	10700	10900	17.1	3.2	3.8	2.49
6832	10900	13800	17.2	2.6	3.2	3.08
6834	13400	16800	17.1	2.6	3.0	4.11
6836	13600	17600	17.2	2.4	2.8	4.36
6838	16400	21000	17.1	2.2	2.6	5.57
6840	16600	22000	17.2	2.2	2.6	5.85

C_r = Dynamic Radial Load Rating
 C_{or} = Static Radial Load Rating Engineering.

Note: Limiting speeds are lower with contact seals. For more information, contact NSK Engineering.



Ball Bearings

6900 Series

Single Row, Deep Groove, Conrad Type

Bearing Number	Nominal Bearing Dimensions						Preferred Shoulder Diameters			
	<i>d</i>		<i>D</i>		<i>B</i>		<i>r</i> *	<i>da</i> (in)		<i>Da</i> (in)
	mm	inch	mm	inch	mm	inch	inch	min	max	max
6900	10	0.3937	22	0.8661	6	0.2362	0.012	0.472	0.492	0.787
6901	12	0.4724	24	0.9449	6	0.2362	0.012	0.551	0.571	0.866
6902	15	0.5906	28	1.1024	7	0.2756	0.012	0.669	0.669	1.024
6903	17	0.6693	30	1.1811	7	0.2756	0.012	0.748	0.768	1.102
6904	20	0.7874	37	1.4567	9	0.3543	0.012	0.866	0.945	1.378
6905	25	0.9843	42	1.6535	9	0.3543	0.012	1.063	1.122	1.575
6906	30	1.1811	47	1.8504	9	0.3543	0.012	1.260	1.339	1.772
6907	35	1.3780	55	2.1654	10	0.3937	0.024	1.535	1.535	2.008
6908	40	1.5748	62	2.4409	12	0.4724	0.024	1.732	1.811	2.283
6909	45	1.7717	68	2.6772	12	0.4724	0.024	1.929	1.969	2.520
6910	50	1.9685	72	2.8346	12	0.4724	0.024	2.126	2.165	2.677
6911	55	2.1654	80	3.1496	13	0.5118	0.039	2.362	2.421	2.953
6912	60	2.3622	85	3.3465	13	0.5118	0.039	2.559	2.598	3.150
6913	65	2.5591	90	3.5433	13	0.5118	0.039	2.756	2.815	3.346
6914	70	2.7559	100	3.9370	16	0.6299	0.039	2.953	3.051	3.740
6915	75	2.9528	105	4.1339	16	0.6299	0.039	3.150	3.228	3.937
6916	80	3.1496	110	4.3307	16	0.6299	0.039	3.346	3.445	4.134
6917	85	3.3465	120	4.7244	18	0.7087	0.039	3.602	3.720	4.469
6918	90	3.5433	125	4.9213	18	0.7087	0.039	3.799	3.878	4.665
6919	95	3.7402	130	5.1181	18	0.7087	0.039	3.996	4.075	4.862
6920	100	3.9370	140	5.5118	20	0.7874	0.039	4.193	4.370	5.256
6921	105	4.1339	145	5.7087	20	0.7874	0.039	4.390	4.567	5.453
6922	110	4.3307	150	5.9055	20	0.7874	0.039	4.587	4.764	5.650
6924	120	4.7244	165	6.4961	22	0.8661	0.039	4.980	5.197	6.240
6926	130	5.1181	180	7.0866	24	0.9449	0.059	5.433	5.669	6.772
6928	140	5.5118	190	7.4803	24	0.9449	0.059	5.827	6.043	7.165
6930	150	5.9055	210	8.2677	28	1.1024	0.079	6.260	6.535	7.913
6932	160	6.2992	220	8.6614	28	1.1024	0.079	6.654	6.929	8.307
6934	170	6.6929	230	9.0551	28	1.1024	0.079	7.047	7.323	8.701
6936	180	7.0866	250	9.8425	33	1.2992	0.079	7.441	7.815	9.488
6938	190	7.4803	260	10.2362	33	1.2992	0.079	7.835	-	9.882
6940	200	7.8740	280	11.0236	38	1.4961	0.079	8.307	8.740	10.591

*Maximum fillet which corner radius of bearing will clear.

Note: Limiting speeds are lower with contact seals. For more information, contact NSK Engineering.

Application Data

Radial Internal Clearance — Table 10.35 page 330
 Bearing Tolerances — Table 10.12 thru Table 10.16 pages 314-17
 Snap Ring Dimensions — Table 10.9 page 310
 Shaft & Housing Fits — Table 10.31 and Table 10.33 pages 328-29

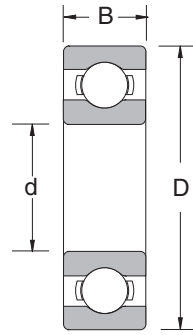
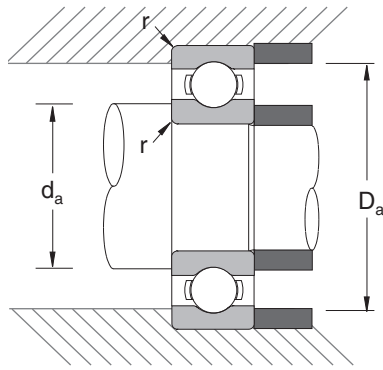

Common Options	
V	: One Non-Contact Seal
VV	: Two Non-Contact Seals
Z	: One Shield
ZZ	: Two Shields
DU	: One Contact Seal
DDU	: Two Contact Seals
NR	: Snap Ring
M††	: Brass Cage
CO†	: Normal Internal Clearance
C3	: Greater Than Normal
E	: Electric Motor Quality

† Not shown in part number
 †† Not available on small sizes,
 Consult NSK for availability.

Bearing Number	Basic Load Ratings (lbs)		Factor f_o	Limiting Speeds (1000 RPM)		Bearing Weight (Approx.) lbs
	C_r	C_{or}		Grease	Oil	
6900	605	284	14.0	32.0	38.0	0.02
6901	649	328	14.5	30.0	36.0	0.02
6902	968	506	14.3	26.0	30.0	0.03
6903	1030	572	14.7	24.0	28.0	0.04
6904	1430	825	14.7	19.0	22.0	0.08
6905	1570	1010	15.4	16.0	19.0	0.09
6906	1630	1120	15.8	14.0	17.0	0.11
6907	2380	1630	15.5	12.0	15.0	0.16
6908	3060	2240	15.7	11.0	13.0	0.24
6909	3170	2440	15.9	9.5	12.0	0.27
6910	3260	2640	16.1	9.0	11.0	0.29
6911	3590	2970	16.2	8.0	9.5	0.40
6912	4360	3650	16.2	7.5	9.0	0.41
6913	3890	3610	16.6	7.1	8.5	0.47
6914	5320	4750	16.3	6.3	7.5	0.75
6915	5460	5060	16.5	6.0	7.4	0.79
6916	5590	5390	16.6	5.6	6.7	0.84
6917	7150	6600	16.4	5.3	6.3	1.19
6918	7370	7040	16.5	5.0	6.0	1.25
6919	7590	7480	16.6	4.8	5.6	1.28
6920	9570	9350	16.4	4.5	5.3	1.78
6921	9460	9460	16.5	4.3	5.3	1.84
6922	9790	10000	16.6	4.3	5.0	1.91
6924	11900	12100	16.5	3.8	4.5	2.62
6926	14600	15100	16.5	3.4	4.0	3.41
6928	15000	16100	16.6	3.2	3.8	3.61
6930	19000	20200	16.5	2.6	3.2	6.56
6932	19500	21600	16.6	2.6	3.0	6.89
6934	19300	21700	16.7	2.4	2.8	7.28
6936	26600	28800	16.4	2.2	2.6	10.76
6938	25300	28600	16.6	2.2	2.6	11.31
6940	32100	35400	16.4	2.0	2.4	15.82

C_r = Dynamic Radial Load Rating
 C_{or} = Static Radial Load Rating Engineering.

Note: Limiting speeds are lower with contact seals. For more information, contact NSK Engineering.

Ball Bearings

63200 Series
Single Row, Deep Groove, Cartridge

Bearing Number	Nominal Bearing Dimensions					Preferred Shoulder Diameters			Basic Load Ratings (lbs)		Bearing Weight (Approx.) lbs
	<i>d</i>		<i>D</i>		<i>B</i>	<i>r*</i>	Shaft	Housing	<i>C_r</i>	<i>C_{or}</i>	
	mm	inch	mm	inch	inch	inch	inch	inch			
63204 DDU	20	0.7874	47	1.8504	0.8125	0.039	0.969	1.614	2870	1480	0.34
63205 DDU	25	0.9843	52	2.0472	0.8125	0.039	1.172	1.811	3150	1760	0.39
63206 DDU	30	1.1811	62	2.4409	0.9375	0.039	1.406	2.205	4370	2540	0.96
63207 DDU	35	1.3780	72	2.8346	1.0625	0.039	1.614	2.559	5780	3440	0.96
63208 DDU	40	1.5748	80	3.1496	1.1875	0.039	1.811	2.874	6550	4010	1.28
63209 DDU	45	1.7717	85	3.3465	1.1875	0.039	2.008	3.071	7050	4590	1.37

*Maximum fillet which corner radius of bearing will clear.

C_r = Dynamic Radial Load Rating
C_{or} = Static Radial Load

Note: Limiting speeds are lower with contact seals. For more information, contact NSK Engineering.

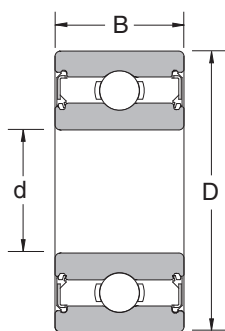

Introduction

Ball Bearings

Cylindrical Roller Bearings

Spherical Roller Bearings

Tapered Roller Bearings

Thrust Bearings

Split Pillow Blocks

Super Precision Bearings

Linear Motion

Rolling Mill Bearings

Engineering Section

Ball Bearings

63300 Series
Single Row, Deep Groove, Cartridge

Bearing Number	Nominal Bearing Dimensions					Preferred Shoulder Diameters			Basic Load Ratings (lbs)		Bearing Weight (Approx.)
	<i>d</i>		<i>D</i>		<i>B</i>	<i>r</i> *	Shaft	Housing	<i>C_r</i>	<i>C_{or}</i>	
	mm	inch	mm	inch	inch	inch	inch	inch			lbs
63304 DDU	20	0.7874	52	2.0472	0.8750	0.039	1.016	1.772	3580	1770	0.44
63305 DDU	25	0.9843	62	2.4409	1.0000	0.039	1.220	2.165	4630	2530	0.78
63306 DDU	30	1.1811	72	2.8346	1.1875	0.039	1.469	2.559	5990	3380	1.13
63307 DDU	35	1.3780	80	3.1496	1.3750	0.059	1.688	2.795	7490	4320	1.64
63308 DDU	40	1.5748	90	3.5433	1.4375	0.059	1.929	3.189	9160	5400	2.06
63309 DDU	45	1.7717	100	3.9370	1.5625	0.059	2.126	3.583	11910	7210	3.00
63310 DDU	50	1.9685	110	4.3307	1.7500	0.079	2.362	3.937	13940	8610	3.75
63311 DDU	55	2.1654	120	4.7244	1.9375	0.079	2.559	4.331	16070	10040	5.12
63312 DDU	60	2.3622	130	5.1181	2.1250	0.079	2.835	4.646	18400	11700	6.50

*Maximum fillet which corner radius of bearing will clear.

C_r = Dynamic Radial Load Rating
C_{or} = Static Radial Load

Note: Limiting speeds are lower with contact seals. For more information, contact NSK Engineering.

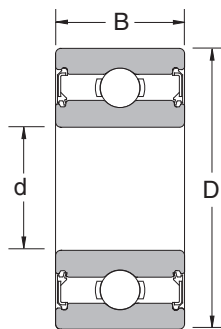



Ball Bearings

1200/1300 Series
Double Row, Self-Aligning

Bearing Number	Nominal Bearing Dimensions						Preferred Shoulder Diameters		
	<i>d</i>		<i>D</i>		<i>B</i>		<i>r</i> *	da (in)	Da (in)
	mm	inch	mm	inch	mm	inch	inch	min	max
1200	10	0.3937	30	1.1811	9	0.3543	0.024	0.552	1.024
1201	12	0.4724	32	1.2598	10	0.3937	0.024	0.630	1.103
1301	12	0.4724	37	1.4567	12	0.4724	0.039	0.670	1.261
1202	15	0.5906	35	1.3780	11	0.4331	0.024	0.749	1.221
1302	15	0.5906	42	1.6535	13	0.5118	0.039	0.788	1.458
1203	17	0.6693	40	1.5748	12	0.4724	0.024	0.827	1.418
1303	17	0.6693	47	1.8504	14	0.5512	0.039	0.867	1.655
1204	20	0.7874	47	1.8504	14	0.5512	0.039	0.985	1.655
1304	20	0.7874	52	2.0472	15	0.5906	0.039	1.044	1.793
1205	25	0.9843	52	2.0472	15	0.5906	0.039	1.182	1.852
1305	25	0.9843	62	2.4409	17	0.6693	0.039	1.241	2.187
1206	30	1.1811	62	2.4409	16	0.6299	0.039	1.379	2.246
1306	30	1.1811	72	2.8346	19	0.7480	0.039	1.438	2.581
1207	35	1.3780	72	2.8346	17	0.6693	0.039	1.635	2.581
1307	35	1.3780	80	3.1496	21	0.8268	0.059	1.694	2.837
1208	40	1.5748	80	0.3150	18	0.7087	0.039	1.832	2.896
1308	40	1.5748	90	3.5433	23	0.9055	0.059	1.891	3.231
1209	45	1.7717	85	3.3465	19	0.7480	0.039	2.029	3.093
1309	45	1.7717	100	3.9370	25	0.9843	0.059	2.088	3.625
1210	50	1.9685	90	3.5433	20	0.7874	0.039	2.226	3.290
1310	50	1.9685	110	4.3307	27	1.0630	0.079	2.325	3.979
1211	55	2.1654	100	3.9370	21	0.8268	0.059	2.482	3.625
1311	55	2.1654	120	4.7244	29	1.1417	0.079	2.522	4.373
1212	60	2.3622	110	4.3307	22	0.8661	0.059	2.679	4.019
1312	60	2.3622	130	5.1181	31	1.2205	0.079	2.797	4.689
1213	65	2.5591	120	4.7244	23	0.9055	0.059	2.876	4.413
1313	65	2.5591	140	5.5118	33	1.2992	0.079	2.994	5.083
1214	70	2.7559	125	4.9213	24	0.9449	0.059	3.073	4.610
1314	70	2.7559	150	5.9055	35	1.3780	0.079	3.191	5.477
1215	75	2.9528	130	5.1181	25	0.9843	0.059	3.270	4.807
1315	75	2.9528	160	6.2992	37	1.4567	0.079	3.388	5.871

*Maximum fillet which corner radius of bearing will clear.

Note: Limiting speeds are lower with contact seals. For more information, contact NSK Engineering.

Application Data

Bearing Tolerances — Table 10.12 thru Table 10.16 pages 314-17
 Snap Ring Dimensions — Table 10.9 page 310
 Shaft & Housing Fits — Table 10.31 and Table 10.33 pages 328-29

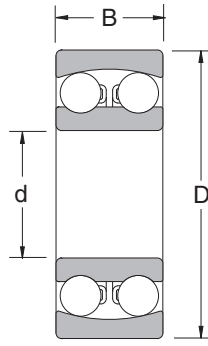
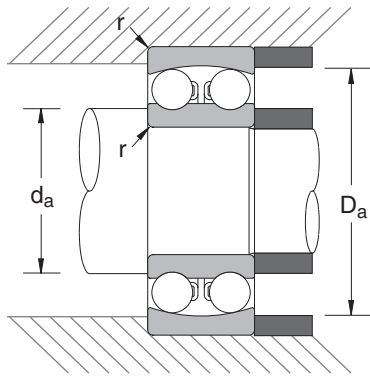

Common Options	
E	: Extra Capacity
K	: Tapered Bore
CO†	: Normal Internal Clearance
C3	: Looser than Normal
† Not shown in part number	

Bearing Number	Basic Load Ratings (lbs)		Limiting Speeds (1000 RPM)		Bearing Weight (Approx.)
	C_r	C_{or}	Grease	Oil	lbs
1200	1240	344	24.0	30.0	0.07
1201	1260	373	24.0	30.0	0.09
1301	2140	629	18.0	22.0	0.15
1202	1690	513	20.0	36.0	0.11
1302	2140	674	17.0	20.0	0.21
1203	1800	596	18.0	22.0	0.16
1303	2810	933	15.0	17.0	0.30
1204	2250	776	15.0	18.0	0.26
1304	2810	989	13.0	15.0	0.38
1205	2740	989	13.0	16.0	0.30
1305	4050	1510	11.0	13.0	0.61
1206	3510	1390	11.0	14.0	0.49
1306	4770	1910	9.0	11.0	0.90
1207	3600	1560	9.5	12.0	0.73
1307	5620	2380	8.0	9.5	1.18
1208	4340	1980	8.5	10.0	0.92
1308	6520	2900	7.0	8.5	1.64
1209	4950	2250	7.5	9.0	1.02
1309	8540	3820	6.3	7.5	2.19
1210	5130	2470	7.0	8.5	1.17
1310	9330	4340	5.6	6.7	2.84
1211	6070	3080	6.3	7.5	1.53
1311	11500	5400	5.0	6.0	3.62
1212	6740	3600	5.6	6.7	1.98
1312	12800	6290	4.5	5.3	4.48
1213	6970	3890	5.3	6.3	2.54
1313	13900	6970	4.3	5.0	5.56
1214	7760	4270	5.0	6.0	2.84
1314	16900	8430	4.0	4.8	6.79
1215	8770	3530	4.3	5.3	2.98
1315	18000	6740	3.8	4.5	7.83

C_r = Dynamic Radial Load Rating
 C_{or} = Static Radial Load RatingEngineering.

Note: Limiting speeds are lower with contact seals. For more information, contact NSK Engineering.



Ball Bearings

2200/2300 Series
Double Row, Self-Aligning

Bearing Number	Nominal Bearing Dimensions						Preferred Shoulder Diameters		
	<i>d</i>		<i>D</i>		<i>B</i>		<i>r</i> *	<i>da</i> (in)	<i>Da</i> (in)
	mm	inch	mm	inch	mm	inch	inch	min	max
2200	10	0.3937	30	1.1811	14	0.5512	0.024	0.552	1.024
2201	12	0.4724	32	1.2598	14	0.5512	0.024	0.630	1.103
2202	15	0.5906	35	1.3780	14	0.5512	0.024	0.749	1.221
2302	15	0.5906	42	1.6535	17	0.6693	0.039	0.788	1.458
2203	17	0.6693	40	1.5748	16	0.6299	0.024	0.827	1.418
2303	17	0.6693	47	1.8504	19	0.7480	0.039	0.867	1.655
2204	20	0.7874	47	1.8504	18	0.7087	0.039	0.985	1.655
2304	20	0.7874	52	2.0472	21	0.8268	0.043	1.044	1.793
2205	25	0.9843	52	2.0472	18	0.7087	0.039	1.182	1.852
2305	25	0.9843	62	2.4409	24	0.9449	0.043	1.241	2.187
2206	30	1.1811	62	2.4409	20	0.7874	0.039	1.379	2.246
2306	30	1.1811	72	2.8346	27	1.0630	0.043	1.438	2.581
2207	35	1.3780	72	2.8346	23	0.9055	0.043	1.635	2.581
2307	35	1.3780	80	3.1496	31	1.2205	0.059	1.694	2.837
2208	40	1.5748	80	3.1496	23	0.9055	0.043	1.832	2.896
2308	40	1.5748	90	3.5433	33	1.2992	0.059	1.891	3.231
2209	45	1.7717	85	3.3465	23	0.9055	0.043	2.029	3.093
2309	45	1.7717	100	3.9370	36	1.4173	0.059	2.088	3.625
2210	50	1.9685	90	3.5433	23	0.9055	0.043	2.226	3.290
2310	50	1.9685	110	4.3307	40	1.5748	0.079	2.325	3.979
2211	55	2.1654	100	3.9370	25	0.9843	0.059	2.482	3.625
2311	55	2.1654	120	4.7244	43	1.6929	0.079	2.522	4.373
2212	60	2.3622	110	4.3307	28	1.1024	0.059	2.679	4.019
2312	60	2.3622	130	5.1181	46	1.8110	0.079	2.797	4.689
2213	65	2.5591	120	4.7244	31	1.2205	0.059	2.876	4.413
2313	65	2.5591	140	5.5118	48	1.8898	0.079	2.994	5.083
2214	70	2.7559	125	4.9213	31	1.2205	0.059	3.073	4.610
2314	70	2.7559	150	5.9055	51	2.0079	0.079	3.191	5.477
2215	75	2.9528	130	5.1181	31	1.2205	0.059	3.270	4.807
2315	75	2.9528	160	6.2992	55	2.1654	0.079	3.388	5.871
2216	80	3.1496	140	5.5118	33	1.2992	0.079	3.507	5.161
2316	80	3.1496	170	6.6929	58	2.2835	0.079	3.585	6.265

*Maximum fillet which corner radius of bearing will clear.

Note: Limiting speeds are lower with contact seals. For more information, contact NSK Engineering.

Application Data

Bearing Tolerances — Table 10.12 thru Table 10.16 pages 314-17
 Snap Ring Dimensions — Table 10.9 page 310
 Shaft & Housing Fits — Table 10.31 and Table 10.33 pages 328-29

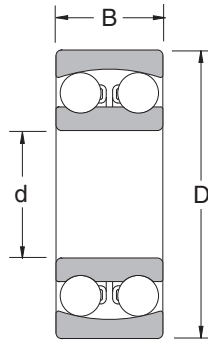
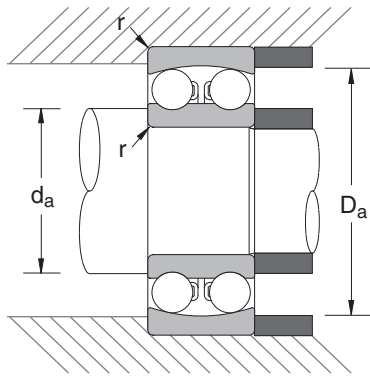

Common Options	
E	: Extra Capacity
K	: Tapered Bore
CO†	: Normal Internal Clearance
C3	: Looser than Normal
† Not shown in part number	
‡ Load ratings are lower, please consult NSK	

Bearing Number	Basic Load Ratings (lbs)		Limiting Speeds (1000 RPM)		Bearing Weight (Approx.) lbs
	C_r	C_{or}	Grease	Oil	
2200	1620	459	24.0	30.0	0.10
2201	1690	504	24.0	30.0	0.12
2202	1720	540	22.0	26.0	0.13
2302	2290	843	16.0	19.0	0.24
2203	2200	708	17.0	20.0	0.19
2303	3210	1020	14.0	17.0	0.39
2204	3210	1050	14.0	17.0	0.31
2304	4050	1370	13.0	16.0	0.52
2205	3820	1320	12.0	15.0	0.35
2305	5510	1910	10.0	13.0	0.82
2206	5730	2020	9.5	12.0	0.55
2306	7080	2560	8.5	10.0	1.22
2207	7190	2650	8.0	9.5	0.88
2307	8770	3280	7.5	9.0	1.64
2208	7080	2810	7.5	9.0	1.08
2308	10100	3960	6.7	8.0	2.20
2209	6290	2700	7.1	8.5	1.17
2309	12100	4950	6.0	7.1	2.91
2210	6290	2900	6.7	8.0	1.26
2310	14400	5960	5.3	6.3	3.92
2211	5960	3010	6.3	7.5	1.83
2311	16900	7080	4.8	5.6	5.05
2212	7640	3890	5.6	6.7	2.54
2312	19400	8430	4.3	5.0	6.24
2213	9890	5040	5.0	6.0	3.35
2313	21400	9670	4.0	4.8	7.56
2214	9890	5220	4.8	5.6	3.51
2314	24700	11200	3.6	4.5	9.19
2215	10000	4000	4.3	5.3	3.40
2315	28100	9670	3.4	4.3	10.30
2216	11000	4470	4.0	5.0	4.19
2316	29200	10100	3.2	4.0	11.99

C_r = Dynamic Radial Load Rating
 C_{or} = Static Radial Load Rating Engineering.

Note: Limiting speeds are lower with contact seals. For more information, contact NSK Engineering.



Ball Bearings

3200/3300 Series
Double Row, Maximum Capacity

Bearing Number	Nominal Bearing Dimensions						Preferred Shoulder Diameters		
	<i>d</i>		<i>D</i>		<i>B</i>		<i>r</i> *	<i>da</i> (in)	<i>Da</i> (in)
	mm	inch	mm	inch	mm	inch	inch	min	max
3200 J	10	0.3937	30	1.1811	14.0	0.5512	0.023	0.546	1.014
3201 J	12	0.4724	32	1.2598	15.9	0.6260	0.023	0.624	1.092
3202 J	15	0.5906	35	1.3780	15.9	0.6260	0.023	0.741	1.209
3302 J	15	0.5906	42	1.6535	19.0	0.7480	0.039	0.819	1.404
3203 J	17	0.6693	40	1.5748	17.5	0.6890	0.023	0.819	1.404
3303 J	17	0.6693	47	1.8504	22.2	0.8740	0.039	0.897	1.599
3204 J	20	0.7874	47	1.8504	20.6	0.8110	0.039	1.014	1.599
3304 J	20	0.7874	52	2.0472	22.2	0.8740	0.039	1.053	1.755
3205 J	25	0.9843	52	2.0472	20.6	0.8110	0.039	1.209	1.794
3305 J	25	0.9843	62	2.4409	25.4	1.0000	0.039	1.209	2.145
3206 J	30	1.1811	62	2.4409	23.8	0.9370	0.039	1.404	2.184
3306 J	30	1.1811	72	2.8346	30.2	1.1890	0.039	1.443	2.535
3207 J	35	1.3780	72	2.8346	27.0	1.0630	0.039	1.638	2.535
3307 J	35	1.3780	80	3.1496	34.9	1.3740	0.059	1.716	2.769
3208 J	40	1.5748	80	3.1496	30.2	1.1890	0.039	1.833	2.847
3308 J	40	1.5748	90	3.5433	36.5	1.4370	0.059	1.911	3.159
3209 J	45	1.7717	85	3.3465	30.2	1.1890	0.039	2.028	3.042
3309 J	45	1.7717	100	3.9370	39.7	1.5630	0.059	2.106	3.549
3210 J	50	1.9685	90	3.5433	30.2	1.1890	0.039	2.223	3.237
3310 J	50	1.9685	110	4.3307	44.4	1.7480	0.078	2.340	3.900
3211 J	55	2.1654	100	3.9370	33.3	1.3110	0.059	2.496	3.549
3311 J	55	2.1654	120	4.7244	49.2	1.9370	0.078	2.535	4.290
3212 J	60	2.3622	110	4.3307	36.5	1.4370	0.059	2.691	3.939
3312 J	60	2.3622	130	5.1181	54.0	2.1260	0.078	2.808	4.602
3213 J	65	2.5591	120	4.7244	38.1	1.5000	0.059	2.886	4.329
3313 J	65	2.5591	140	5.5118	58.7	2.3110	0.078	3.003	4.992
3214 J	70	2.7559	125	4.9213	39.7	1.5630	0.059	3.081	4.524
3314 J	70	2.7559	150	5.9055	63.5	2.5000	0.078	3.198	5.382

*Maximum fillet which corner radius of bearing will clear.

Note: Limiting speeds are lower with contact seals. For more information, contact NSK Engineering.

Application Data

Bearing Tolerances — Table 10.12 thru Table 10.16 pages 314-17
 Snap Ring Dimensions — Table 10.9 page 310
 Shaft & Housing Fits — Table 10.31 and Table 10.33 pages 328-29

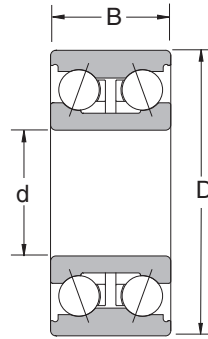
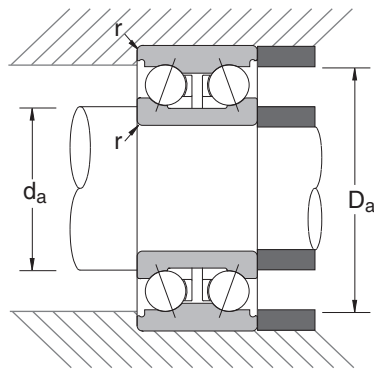

Common Options	
NR	: Snap Ring
CO†	: Normal Internal Clearance
C3	: Greater than Normal
† Not shown in part number	

Bearing Number	Basic Load Ratings (lbs)		Limiting Speeds (1000 RPM)		Bearing Weight (Approx.)
	C_r	C_{or}	Grease	Oil	lbs
3200 J	1820	1330	17.0	24.0	0.11
3201 J	2180	1620	15.0	20.0	0.14
3202 J	2470	1890	13.0	18.0	0.16
3302 J	3190	2380	12.0	17.0	0.29
3203 J	2880	2290	12.0	17.0	0.23
3303 J	4520	3420	10.0	15.0	0.42
3204 J	3960	3240	10.0	15.0	0.37
3304 J	4610	3570	9.5	14.0	0.51
3205 J	4360	3840	8.5	12.0	0.43
3305 J	6320	5150	7.5	10.0	0.81
3206 J	5940	5440	7.0	9.5	0.70
3306 J	8410	7010	6.3	8.5	1.29
3207 J	8410	7940	6.3	8.5	1.06
3307 J	10600	9130	5.6	7.5	1.80
3208 J	9290	8680	5.6	7.5	1.44
3308 J	13100	11900	4.8	6.3	2.35
3209 J	9890	10100	5.0	6.7	1.56
3309 J	16000	15100	4.3	5.6	3.08
3210 J	11100	11300	4.8	6.3	1.68
3310 J	19100	18300	4.0	5.3	4.29
3211 J	13200	12100	4.3	5.6	2.31
3311 J	22000	21400	3.6	4.8	5.61
3212 J	15600	16200	3.8	5.0	3.08
3312 J	25600	25200	3.4	4.5	7.15
3213 J	16500	18700	3.6	4.8	3.85
3313 J	29000	29000	3.2	4.3	9.02
3214 J	18300	20600	3.2	4.3	4.18
3314 J	32100	32800	2.8	3.8	11.11

C_r = Dynamic Radial Load Rating
 C_{or} = Static Radial Load Rating Engineering.

Note: Limiting speeds are lower with contact seals. For more information, contact NSK Engineering.

Introduction

Ball Bearings

Cylindrical Roller Bearings

Spherical Roller Bearings

Tapered Roller Bearings

Thrust Bearings

Split Pillow Blocks

Super Precision Bearings

Linear Motion

Rolling Mill Bearings

Engineering Section



Ball Bearings

5200/5300 Series
Double Row, Conrad Type

Bore Sizes: 10mm to 40mm

Bearing Number	Nominal Bearing Dimensions						Preferred Shoulder Diameters		
	<i>d</i>		<i>D</i>		<i>B</i>		<i>r</i> *	<i>da</i> (in)	<i>Da</i> (in)
	mm	inch	mm	inch	mm	inch	inch	min	max
5200 TNG	10	0.3937	30	1.1811	14.0	0.5512	0.023	0.585	0.984
5200 J	10	0.3937	30	1.1811	14.0	0.5512	0.023	0.585	0.984
5201 TNG	12	0.4724	32	1.2598	15.9	0.6260	0.023	0.663	1.063
5201 J	12	0.4724	32	1.2598	15.9	0.6260	0.023	0.663	1.063
5202 TNG	15	0.5906	35	1.3780	15.9	0.6260	0.023	0.787	1.170
5202 J	15	0.5906	35	1.3780	15.9	0.6260	0.023	0.787	1.404
5302 TNG	15	0.5906	42	1.6535	19.0	0.7480	0.039	0.819	1.404
5203 TNG	17	0.6693	40	1.5748	17.5	0.6890	0.023	0.866	1.380
5203 J	17	0.6693	40	1.5748	17.5	0.6890	0.023	0.866	1.380
5303 TNG	17	0.6693	47	1.8504	22.2	0.8740	0.039	0.906	1.615
5303 J	17	0.6693	47	1.8504	22.2	0.8740	0.039	0.906	1.615
5204 TNG	20	0.7874	47	1.8504	20.6	0.8110	0.039	1.014	1.614
5204 J	20	0.7874	47	1.8504	20.6	0.8110	0.039	1.014	1.614
5304 TNG	20	0.7874	52	2.0472	22.2	0.8740	0.039	1.053	1.772
5304 J	20	0.7874	52	2.0472	22.2	0.8740	0.039	1.053	1.772
5205 TNG	25	0.9843	52	2.0472	20.6	0.8110	0.039	1.220	1.811
5205 J	25	0.9843	52	2.0472	20.6	0.8110	0.039	1.220	1.811
5305 TNG	25	0.9843	62	2.4409	25.4	1.0000	0.039	1.260	2.165
5305 J	25	0.9843	62	2.4409	25.4	1.0000	0.039	1.260	2.165
5206 TNG	30	1.1811	62	2.4409	23.8	0.9370	0.039	1.404	2.205
5206 J	30	1.1811	62	2.4409	23.8	0.9370	0.039	1.404	2.205
5306 TNG	30	1.1811	72	2.8346	30.2	1.1890	0.039	1.457	2.559
5306 J	30	1.1811	72	2.8346	30.2	1.1890	0.039	1.457	2.559
5207 TNG	35	1.3780	72	2.8346	27.0	1.0630	0.039	1.638	2.559
5207 J	35	1.3780	72	2.8346	27.0	1.0630	0.039	1.638	2.559
5307 TNG	35	1.3780	80	3.1496	34.9	1.3740	0.059	1.716	2.795
5307 J	35	1.3780	80	3.1496	34.9	1.3740	0.059	1.716	2.795
5208 TNG	40	1.5748	80	3.1496	30.2	1.1890	0.039	1.833	2.874
5208 J	40	1.5748	80	3.1496	30.2	1.1890	0.039	1.833	2.874
5308 TNG	40	1.5748	90	3.5433	36.5	1.4370	0.059	1.911	3.189
5308 J	40	1.5748	90	3.5433	36.5	1.4370	0.059	1.911	3.189

*Maximum fillet which corner radius of bearing will clear.

Note: Limiting speeds are lower with contact seals. For more information, contact NSK Engineering.

Application Data

Bearing Tolerances — Table 10.12 thru Table 10.16 pages 314-17
 Snap Ring Dimensions — Table 10.9 page 310
 Shaft & Housing Fits — Table 10.31 and Table 10.33 pages 328-29

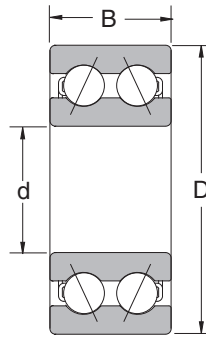
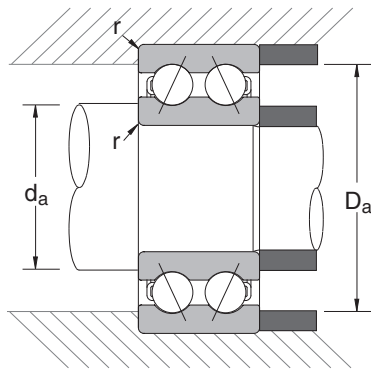

Common Options	
2RS††	: Two Seals
ZZ	: Two Shields
NR	: Snap Ring
J	: Steel Cage
TNG	: Polyamide Cage
CO†	: Normal Internal Clearance
C3	: Looser Than Normal
† Not shown in part number	
†† Available with TNG only	

Bearing Number	Basic Load Ratings (lbs)		Limiting Speeds (1000 RPM)		Bearing Weight (Approx.) lbs
	C_r	C_{or}	Grease	Oil	
5200 TNG	1750	877	16.0	22.0	0.09
5200 J	1610	878	17.0	22.0	0.10
5201 TNG	2380	1150	15.0	20.0	0.11
5201 J	2360	1300	15.0	20.0	0.12
5202 TNG	2650	1370	13.0	18.0	0.13
5202 J	2630	1580	13.0	17.0	0.14
5302 TNG	3660	1940	10.0	15.0	0.25
5203 TNG	3280	1750	10.0	15.0	0.19
5203 J	3290	2030	11.0	15.0	0.20
5303 TNG	4680	2380	9.5	14.0	0.35
5303 J	4730	2830	10.0	13.0	0.31
5204 TNG	4410	2430	9.0	13.0	0.31
5204 J	4410	2790	10.0	13.0	0.26
5304 TNG	5220	2900	8.5	12.0	0.43
5304 J	5530	3370	9.0	12.0	0.51
5205 TNG	4770	2860	8.0	11.0	0.35
5205 J	4790	3310	8.5	11.0	0.42
5305 TNG	6740	3890	7.5	10.0	0.70
5305 J	7330	4650	7.5	10.0	0.75
5206 TNG	6740	4110	7.1	9.0	0.58
5206 J	6650	4740	7.1	9.5	0.64
5306 TNG	9330	5510	6.2	7.9	1.09
5306 J	9150	6320	6.3	8.5	1.12
5207 TNG	8770	5620	5.6	7.1	0.91
5207 J	8770	6450	6.3	8.0	0.95
5307 TNG	11500	6740	5.1	6.5	1.46
5307 J	11500	8100	5.6	7.5	1.74
5208 TNG	10800	7080	5.0	6.3	1.21
5208 J	9930	7510	5.3	7.1	1.26
5308 TNG	13900	8770	4.7	5.8	1.99
5308 J	12700	9250	5.3	6.7	2.30

C_r = Dynamic Radial Load Rating
 C_{or} = Static Radial Load RatingEngineering.

Note: Limiting speeds are lower with contact seals. For more information, contact NSK Engineering.



Ball Bearings

5200/5300 Series (Continued)

Double row, Conrad Type

Bore Sizes: 45mm to 85mm

Bearing Number	Nominal Bearing Dimensions						Preferred Shoulder Diameters		
	<i>d</i>		<i>D</i>		<i>B</i>		<i>r</i> *	<i>da</i> (in)	<i>Da</i> (in)
	mm	inch	mm	inch	mm	inch	inch	min	max
5209 TNG	45	1.7717	85	3.3465	30.2	1.1890	0.039	2.047	3.071
5209 J	45	1.7717	85	3.3465	30.2	1.1890	0.039	2.047	3.071
5309 TNG	45	1.7717	100	3.9370	39.7	1.5630	0.059	2.126	3.583
5309 J	45	1.7717	100	3.9370	39.7	1.5630	0.059	2.126	3.583
5210 TNG	50	1.9685	90	3.5433	30.2	1.1890	0.039	2.224	3.268
5210 J	50	1.9685	90	3.5433	30.2	1.1890	0.039	2.224	3.268
5310 TNG	50	1.9685	110	4.3307	44.4	1.7480	0.078	2.362	3.937
5310 J	50	1.9685	110	4.3307	44.4	1.7480	0.078	2.362	3.937
5211 TNG	55	2.1654	100	3.9370	33.3	1.3110	0.059	2.520	3.602
5211 J	55	2.1654	100	3.9370	33.3	1.3110	0.059	2.520	3.602
5311 TNG	55	2.1654	120	4.7244	49.2	1.9370	0.078	2.559	4.331
5311 J	55	2.1654	120	4.7244	49.2	1.9370	0.078	2.559	4.331
5212 TNG	60	2.3622	110	4.3307	36.5	1.4370	0.059	2.717	3.996
5212 J	60	2.3622	110	4.3307	36.5	1.4370	0.059	2.717	3.996
5312 TNG	60	2.3622	130	5.1181	54.0	2.1260	0.078	2.835	4.646
5312 J	60	2.3622	130	5.1181	54.0	2.1260	0.078	2.835	4.646
5213 TNG	65	2.5591	120	4.7244	38.1	1.5000	0.059	2.913	4.370
5213 J	65	2.5591	120	4.7244	38.1	1.5000	0.059	2.913	4.370
5313 TNG	65	2.5591	140	5.5118	58.7	2.3110	0.078	3.034	5.039
5313 J	65	2.5591	140	5.5118	58.7	2.3110	0.078	3.034	5.039
5214 TNG	70	2.7559	125	4.9213	39.7	1.5630	0.059	3.110	4.567
5214 J	70	2.7559	125	4.9213	39.7	1.5630	0.059	3.110	4.567
5314 J	70	2.7559	150	5.9055	63.5	2.5000	0.078	3.228	5.433
5215 J	75	2.9528	130	5.1181	41.3	1.6260	0.059	3.307	4.764
5216 J	80	3.1496	140	5.5118	44.4	1.7480	0.078	3.543	5.118
5217 J	85	3.3465	150	5.9055	49.2	1.9370	0.078	3.740	5.512

*Maximum fillet which corner radius of bearing will clear.

Note: Limiting speeds are lower with contact seals. For more information, contact NSK Engineering.

Application Data

Bearing Tolerances — Table 10.12 thru Table 10.16 pages 314-17

Snap Ring Dimensions — Table 10.9 page 310

Shaft & Housing Fits — Table 10.31 and Table 10.33 pages 328-29

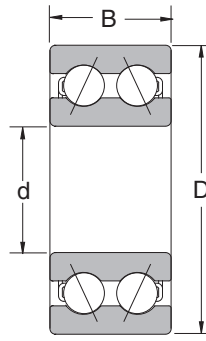
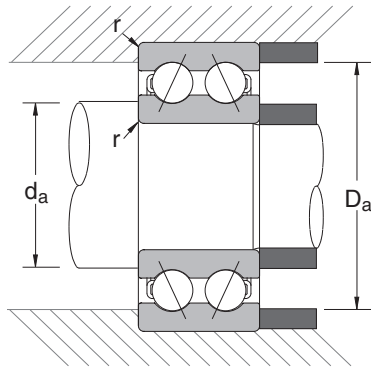

Common Options	
2RS††	: Two Seals
ZZ	: Two Shields
NR	: Snap Ring
J	: Steel Cage
TNG	: Polyamide Cage
CO†	: Normal Internal Clearance
C3	: Looser Than Normal
† Not shown in part number	
†† Available with TNG only	

Bearing Number	Basic Load Ratings (lbs)		Limiting Speeds (1000 RPM)		Bearing Weight (Approx.)
	C_r	C_{or}	Grease	Oil	lbs
5209 TNG	10800	7190	4.5	5.4	1.28
5209 J	11100	8580	5.0	6.7	1.37
5309 TNG	15300	9780	4.3	5.0	2.66
5309 J	15400	11400	4.5	6.0	3.10
5210 TNG	11500	8210	4.0	4.6	1.39
5210 J	11900	9740	4.8	6.0	1.48
5310 TNG	18200	11900	3.6	4.2	3.52
5310 J	18300	13800	4.3	5.6	4.30
5211 TNG	13200	9670	4.3	5.6	1.93
5211 J	12600	11000	4.3	5.6	2.12
5311 TNG	22900	15300	3.8	5.0	4.64
5311 J	21400	16400	3.8	5.0	5.10
5212 TNG	16200	11900	3.8	5.0	2.60
5212 J	15600	13900	3.8	5.0	2.98
5312 TNG	28100	19100	3.4	4.5	5.94
5312 J	28200	22100	3.4	4.5	7.00
5213 TNG	18000	14200	3.4	4.5	3.34
5213 J	17100	15500	3.6	4.5	3.64
5313 TNG	33700	22900	3.2	4.3	7.46
5313 J	25400	32000	3.2	4.3	8.49
5214 TNG	18700	15100	3.4	4.5	3.61
5214 J	21100	18500	3.4	4.5	4.00
5314 J	35700	28900	3.0	3.8	10.80
5215 J	21100	18700	3.2	4.3	4.19
5216 J	22300	20900	3.0	3.8	5.51
5217 J	26000	24700	2.8	3.6	7.50

C_r = Dynamic Radial Load Rating
 C_{or} = Static Radial Load Rating Engineering.

Note: Limiting speeds are lower with contact seals. For more information, contact NSK Engineering.



Ball Bearings

7200 Series
Angular Contact, 40° Contact Angle

Bearing Number	Nominal Bearing Dimensions						Preferred Shoulder Diameters		
	<i>d</i>		<i>D</i>		<i>B</i>		<i>r</i> *	<i>da</i> (in)	<i>Da</i> (in)
	mm	inch	mm	inch	mm	inch	inch	min	max
7200B	10	0.3937	30	1.1811	9	0.3543	0.024	0.591	0.984
7201B	12	0.4724	32	1.2598	10	0.3937	0.024	0.669	1.063
7202B	15	0.5906	35	1.3780	11	0.5331	0.024	0.787	1.181
7203B	17	0.6693	40	1.5748	12	0.4724	0.024	0.866	1.378
7204B	20	0.7874	47	1.8504	14	0.5512	0.039	1.024	1.614
7205B	25	0.9843	52	2.0472	15	0.5906	0.039	1.220	1.911
7206B	30	1.1811	62	2.4409	16	0.6299	0.039	1.417	2.205
7207B	35	1.3780	72	2.8346	17	0.6693	0.039	1.654	2.559
7208B	40	1.5748	80	3.1496	18	0.7087	0.039	1.850	2.874
7209B	45	1.7717	85	3.3465	19	0.7480	0.039	2.047	3.071
7210B	50	1.9685	90	3.5433	20	0.7874	0.039	2.244	3.268
7211B	55	2.1654	100	3.9370	21	0.8268	0.059	2.500	3.602
7212B	60	2.3622	110	4.3307	22	0.8661	0.059	2.697	3.996
7213B	65	2.5591	120	4.7244	23	0.9005	0.059	2.894	4.390
7214B	70	2.7559	125	4.9213	24	0.9449	0.059	3.091	4.587
7215B	75	2.9528	130	5.1181	25	0.9843	0.059	3.287	4.783
7216B	80	3.1496	140	5.5118	26	1.0236	0.079	3.543	5.118
7217B	85	3.3465	150	5.9055	28	1.1024	0.079	3.740	5.512
7218B	90	3.5433	160	6.2992	30	1.1811	0.079	3.937	5.906
7219B	95	3.7402	170	6.6929	32	1.2598	0.079	4.213	6.220
7220B	100	3.9370	180	7.0866	34	1.3386	0.079	4.409	6.614
7221B	105	4.1339	190	7.4803	36	1.4173	0.079	4.606	7.008
7222B	110	4.3307	200	7.8740	38	1.4961	0.079	4.803	7.402
7224B	120	4.7244	215	8.4646	40	1.5748	0.079	5.197	7.992
7226B	130	5.1181	230	9.0551	40	1.5748	0.098	5.669	8.504
7228B	140	5.5118	250	9.8425	42	1.6535	0.098	6.063	9.291
7230B	150	5.9055	270	10.6299	45	1.7717	0.098	6.457	10.079
7232B	160	6.2992	290	11.4173	48	1.8898	0.098	6.850	10.866
7234B	170	6.6929	310	12.2047	52	2.0472	0.118	7.402	11.496
7236B	180	7.0866	320	12.5984	52	2.0472	0.118	7.795	11.890
7238B	190	7.4803	340	13.3858	55	2.1654	0.118	8.190	12.677
7240B	200	7.8740	360	14.1732	58	2.2835	0.118	8.583	13.465

*Maximum fillet which corner radius of bearing will clear.

Note: Limiting speeds are lower with contact seals. For more information, contact NSK Engineering.

Application Data

Bearing Tolerances — Table 10.12 thru Table 10.16 pages 314-17
Shaft & Housing Fits — Table 10.31 and Table 10.33 pages 328-29

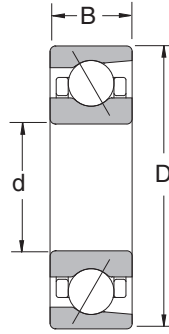
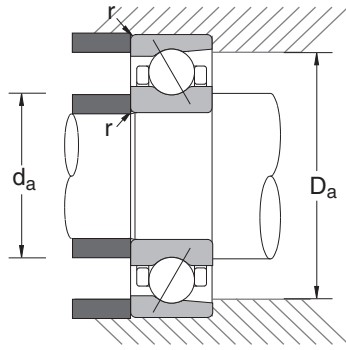

Common Options	
B	: 40° Contact Angle
C††	: 15° Contact Angle
TY	: Polyamide Cage
Y	: Pressed Brass Cage
M	: Machined Brass Cage
W	: Pressed Steel Cage
G	: Flush Ground Faces
PC	: Flush Ground Faces Normal Axial Clearance and ABEC6.

†† Load and speed ratings are not shown in the table below

Bearing Number	Basic Load Ratings (lbs)		Limiting Speeds (1000 RPM)		Bearing Weight (Approx.)
	C_r	C_{or}	Grease	Oil	lbs
7200B	1050	505	20.0	28.0	0.07
7201B	1550	761	18.0	26.0	0.08
7202B	1680	882	16.0	22.0	0.11
7203B	2090	1120	14.0	19.0	0.15
7204B	2800	1570	12.0	16.0	0.24
7205B	3150	1950	10.0	14.0	0.30
7206B	4370	2800	8.5	12.0	0.46
7207B	5780	3810	7.5	10.0	0.65
7208B	6830	4810	6.7	9.0	0.84
7209B	7720	5470	6.3	8.5	0.95
7210B	8050	6000	5.6	8.0	1.07
7211B	9920	7610	5.3	7.1	1.40
7212B	12000	9370	4.8	6.3	1.81
7213B	13700	11100	4.3	6.0	2.20
7214B	14900	12200	4.0	5.6	2.42
7215B	15400	13100	3.8	5.3	3.02
7216B	17300	14700	3.6	5.0	3.68
7217B	20100	17100	3.4	4.8	4.58
7218B	22900	19700	3.2	4.3	5.62
7219B	24900	21200	3.0	4.0	6.83
7220B	28000	24000	2.8	3.8	8.15
7221B	30400	27100	2.6	3.6	9.70
7222B	33100	30200	2.6	3.4	11.40
7224B	37300	36400	2.4	3.2	13.70
7226B	38400	39200	2.2	3.0	15.40
7228B	44300	47800	2.0	2.8	19.40
7230B	50500	57100	1.8	2.6	24.20
7232B	53400	62600	1.7	2.4	30.20
7234B	60000	72800	1.6	2.2	37.50
7236B	62000	78300	1.5	2.0	39.00
7238B	63700	83800	1.4	2.0	47.00
7240B	68300	91500	1.3	1.8	55.80

C_r = Dynamic Radial Load Rating
 C_{or} = Static Radial Load Rating Engineering.

Note: Limiting speeds are lower with contact seals. For more information, contact NSK Engineering.



Ball Bearings

7300 Series
Angular Contact, 40° Contact Angle

Bearing Number	Nominal Bearing Dimensions						Preferred Shoulder Diameters		
	<i>d</i>		<i>D</i>		<i>B</i>		<i>r</i> *	<i>da</i> (in)	<i>Da</i> (in)
	mm	inch	mm	inch	mm	inch	inch	min	max
7300B	10	0.3937	35	1.3780	11	0.4331	0.024	0.591	1.181
7301B	12	0.4724	37	1.4567	12	0.4724	0.039	0.709	1.221
7302B	15	0.5906	42	1.6535	13	0.5118	0.039	0.827	1.418
7303B	17	0.6693	47	1.8504	14	0.5512	0.039	0.906	1.614
7304B	20	0.7874	52	2.0472	15	0.5906	0.039	1.063	1.772
7305B	25	0.9843	62	2.4409	17	0.6693	0.039	1.260	2.165
7306B	30	1.1811	72	2.8346	19	0.7480	0.039	1.457	2.559
7307B	35	1.3780	80	3.1496	21	0.8268	0.059	1.712	2.815
7308B	40	1.5748	90	3.5433	23	0.9055	0.059	1.909	3.209
7309B	45	1.7717	100	3.9370	25	0.9843	0.059	2.106	3.602
7310B	50	1.9685	110	4.3307	27	1.0630	0.079	2.362	3.937
7311B	55	2.1654	120	4.7244	29	1.1417	0.079	2.559	4.331
7312B	60	2.3622	130	5.1181	31	1.2205	0.079	2.835	4.646
7313B	65	2.5591	140	5.5118	33	1.2992	0.079	3.031	5.039
7314B	70	2.7559	150	5.9055	35	1.3780	0.079	3.228	5.433
7315B	75	2.9528	160	6.2992	37	1.4567	0.079	3.425	5.827
7316B	80	3.1496	170	6.6929	39	1.5354	0.079	3.622	6.220
7317B	85	3.3465	180	7.0866	41	1.6142	0.098	3.898	6.535
7318B	90	3.5433	190	7.4803	43	1.6929	0.098	4.094	6.929
7319B	95	3.7402	200	7.8740	45	1.7717	0.098	4.291	7.323
7320B	100	3.9370	215	8.4646	47	1.8504	0.098	4.488	7.913
7321B	105	4.1339	225	8.8583	49	1.9291	0.098	4.685	8.307
7322B	110	4.3307	240	9.4488	50	1.9685	0.098	4.882	8.898
7324B	120	4.7244	260	10.2362	55	2.1654	0.098	5.276	9.685
7326B	130	5.1181	280	11.0236	58	2.2835	0.118	5.827	10.315
7328B	140	5.5118	300	11.8110	62	2.4409	0.118	6.220	11.102
7330B	150	5.9055	320	12.5984	65	2.5591	0.118	6.614	11.890
7332B	160	6.2992	340	13.3858	68	2.6772	0.118	7.008	12.677
7334B	170	6.6929	360	14.1732	72	2.8346	0.118	7.402	13.465
7336B	180	7.0866	380	14.9606	75	2.9528	0.118	7.795	14.252
7338B	190	7.4803	400	15.7480	78	3.0709	0.157	8.346	14.882
7340B	200	7.8740	420	16.5354	80	3.1496	0.157	8.740	15.669

*Maximum fillet which corner radius of bearing will clear.

Note: Limiting speeds are lower with contact seals. For more information, contact NSK Engineering.

Application Data

Bearing Tolerances — Table 10.12 thru Table 10.16 pages 314-17
Shaft & Housing Fits — Table 10.31 and Table 10.33 pages 328-29

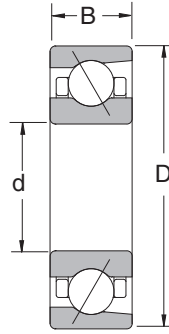
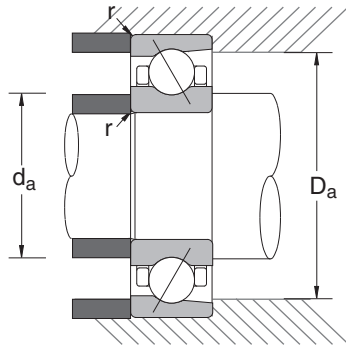

Common Options	
B	: 40° Contact Angle
C††	: 15° Contact Angle
TY	: Polyamide Cage
Y	: Pressed Brass Cage
M	: Machined Brass Cage
W	: Pressed Steel Cage
G	: Flush Ground Faces
PC	: Flush Ground Faces
	Normal Axial Clearance and ABEC6.
†† Load and speed ratings are not shown in the table below	

Bearing Number	Basic Load Ratings (lbs)		Limiting Speeds (1000 RPM)		Bearing Weight (Approx.)
	C_r	C_{or}	Grease	Oil	lbs
7300B	1960	904	18.0	24.0	0.12
7301B	1980	940	16.0	22.0	0.14
7302B	2600	1330	14.0	19.0	0.19
7303B	3110	1620	13.0	17.0	0.26
7304B	3640	1950	11.0	15.0	0.33
7305B	5160	3000	9.0	13.0	0.54
7306B	6550	3950	8.0	11.0	0.79
7307B	7830	4980	7.1	9.5	1.05
7308B	9480	6240	6.3	8.5	1.45
7309B	12300	8270	5.6	7.5	1.93
7310B	14400	9920	5.0	6.7	2.53
7311B	16800	11700	4.5	6.3	3.35
7312B	19100	13600	4.3	5.6	4.41
7313B	21600	15500	3.8	5.3	5.44
7314B	24300	17700	3.6	5.0	6.61
7315B	26500	20100	3.4	4.8	7.93
7316B	28700	22500	3.2	4.3	9.37
7317B	30900	25100	3.0	4.0	11.10
7318B	33100	27800	2.8	3.8	12.90
7319B	35500	30600	2.6	3.6	14.90
7320B	42800	39900	2.4	3.4	18.30
7321B	42800	39900	2.4	3.2	20.70
7322B	45200	44300	2.2	3.0	24.50
7324B	50700	52000	2.0	2.8	31.50
7326B	56200	60400	1.9	2.6	38.30
7328B	62000	69500	1.7	2.4	46.90
7330B	64800	76100	1.6	2.2	55.80
7332B	70600	87100	1.5	2.0	65.70
7334B	79400	100100	1.4	2.0	78.20
7336B	83800	110000	1.3	1.8	90.40
7338B	92600	123200	1.3	1.7	104.00
7340B	97000	135300	1.2	1.6	117.00

C_r = Dynamic Radial Load Rating
 C_{or} = Static Radial Load Rating Engineering.

Note: Limiting speeds are lower with contact seals. For more information, contact NSK Engineering.



Ball Bearings

7400 Series
Angular Contact, 40° Contact Angle

Bearing Number	Nominal Bearing Dimensions						Preferred Shoulder Diameters		
	<i>d</i>		<i>D</i>		<i>B</i>		<i>r</i> *	<i>da</i> (in)	<i>Da</i> (in)
	mm	inch	mm	inch	mm	inch	inch	min	max
7405B	25	0.9843	80	3.1496	21	0.8268	0.059	1.319	2.815
7406B	30	1.1811	90	3.5433	23	0.9055	0.059	1.516	3.209
7407B	35	1.3780	100	3.9370	25	0.9843	0.059	1.713	3.602
7408B	40	1.5748	110	4.3307	27	1.0630	0.079	1.969	3.937
7409B	45	1.7717	120	4.7244	29	1.1417	0.079	2.165	4.331
7410B	50	1.9685	130	5.1181	31	1.2205	0.079	2.441	4.646
7411B	55	2.1654	140	5.5118	33	1.2992	0.079	2.638	5.039
7412B	60	2.3622	150	5.9055	35	1.3780	0.079	2.835	5.433
7413B	65	2.5591	160	6.2992	37	1.4567	0.079	3.031	5.827
7414B	70	2.7559	180	7.0866	42	1.6535	0.098	3.307	6.535
7415B	75	2.9528	190	7.4803	45	1.7717	0.098	3.504	6.929
7416B	80	3.1496	200	7.8740	48	1.8898	0.098	3.701	7.323
7420B ¹	100	3.9370	250	9.8425	58	2.2835	0.118	4.646	9.134
A7420B ¹	100	3.9370	265	10.4331	60	2.3622	0.118	4.646	9.125

*Maximum fillet which corner radius of bearing will clear.

Note: Limiting speeds are lower with contact seals. For more information, contact NSK Engineering.

¹NSK part number 7420 conforms to ISO and ABMA standards. Part number 7420 of other manufacturers may be equivalent to NSK A7420.

Application Data

Bearing Tolerances — Table 10.12 thru Table 10.16 pages 314-17
Shaft & Housing Fits — Table 10.31 and Table 10.33 pages 328-29

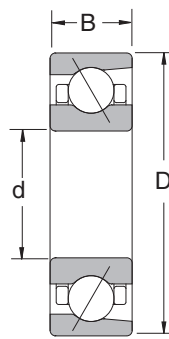
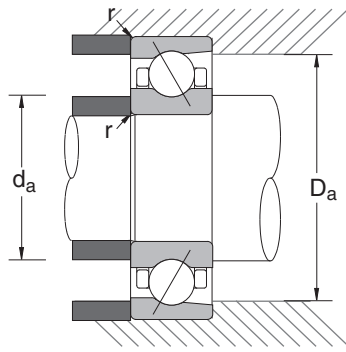

Common Options	
B	: 40° Contact Angle
C††	: 15° Contact Angle
TY	: Polyamide Cage
Y	: Pressed Brass Cage
M	: Machined Brass Cage
W	: Pressed Steel Cage
G	: Flush Ground Faces
PC	: Flush Ground Faces Normal Axial Clearance and ABEC6.
†† Load and speed ratings are not shown in the table below	

Bearing Number	Basic Load Ratings (lbs)		Limiting Speeds (1000 RPM)		Bearing Weight (Approx.) lbs
	C_r	C_{or}	Grease	Oil	
7405B	9700	5310	7.6	10.5	1.4
7406B	10700	6330	6.7	9.2	2.9
7407B	12600	7600	5.9	8.2	3.0
7408B	14600	9000	5.3	7.3	3.1
7409B	16600	10600	4.9	6.7	3.9
7410B	18900	12200	4.5	6.0	4.8
7411B	23200	15400	4.1	5.6	5.8
7412B	24900	17400	3.8	5.2	7.0
7413B	26900	19500	3.5	4.9	8.4
7414B	33300	26500	3.2	4.4	10.4
7415B	37700	31500	3.0	4.1	12.6
7416B	37900	32000	2.8	3.9	16.7
7420B ¹	49800	47800	2.2	3.1	33.0
A7420B ¹	53100	53400	2.1	2.9	40.1

C_r = Dynamic Radial Load Rating
 C_{or} = Static Radial Load Rating Engineering.

Note: Limiting speeds are lower with contact seals. For more information, contact NSK Engineering.

¹NSK part number 7420 conforms to ISO and ABMA standards. Part number 7420 of other manufacturers may be equivalent to NSK A7420.

Ball Bearings

BL200/300 Series
Maximum Capacity Type

Bearing Number	Nominal Bearing Dimensions						Preferred Shoulder Diameters			
	<i>d</i>		<i>D</i>		<i>B</i>		<i>r</i> *	<i>da</i> (in)		<i>Da</i> (in)
	mm	inch	mm	inch	mm	inch	inch	min	max	max
BL205	25	0.9843	52	2.0472	15	0.5906	0.039	1.182	1.261	1.852
BL305	25	0.9843	62	2.4409	17	0.6693	0.039	1.241	1.418	2.187
BL206	30	1.1811	62	2.4409	16	0.6299	0.039	1.379	1.517	2.246
BL306	30	1.1811	72	2.8346	19	0.7480	0.039	1.438	1.655	2.581
BL207	35	1.3780	72	2.8346	17	0.6693	0.039	1.635	1.753	2.581
BL307	35	1.3780	80	3.1496	21	0.8268	0.059	1.694	1.753	2.837
BL208	40	1.5748	80	3.1496	18	0.7087	0.039	1.832	1.970	2.896
BL308	40	1.5748	90	3.5433	23	0.9055	0.059	1.891	2.069	3.231
BL209	45	1.7717	85	3.3465	19	0.7480	0.039	2.029	2.187	3.093
BL309	45	1.7717	100	3.9370	25	0.9843	0.059	2.088	2.423	3.625
BL210	50	1.9685	90	3.5433	20	0.7874	0.039	2.226	2.364	3.290
BL310	50	1.9685	110	4.3307	27	1.0630	0.079	2.325	2.679	3.979
BL211	55	2.1654	100	3.9370	21	0.8268	0.059	2.482	2.620	3.625
BL311	55	2.1654	120	4.7244	29	1.1417	0.079	2.522	2.857	4.373
BL212	60	2.3622	110	4.3307	22	0.8661	0.059	2.679	2.935	4.019
BL312	60	2.3622	130	5.1181	31	1.2205	0.079	2.797	3.113	4.689
BL213	65	2.5591	120	4.7244	23	0.9055	0.059	2.876	3.152	4.413
BL313	65	2.5591	140	5.5118	33	1.2992	0.079	2.994	3.369	5.083
BL214	70	2.7559	125	4.9213	24	0.9449	0.059	3.073	3.310	4.610
BL314	70	2.7559	150	5.9055	35	1.3780	0.079	3.191	3.625	5.477
BL215	75	2.9528	130	5.1181	25	0.9843	0.059	3.270	3.546	4.807
BL315	75	2.9528	160	6.2992	37	1.4567	0.079	3.388	3.881	5.871
BL216	80	3.1496	140	5.5118	26	1.0236	0.079	3.507	3.763	5.161
BL316	80	3.1496	170	6.6929	39	1.5354	0.079	3.585	4.117	6.265
BL217	85	3.3465	150	5.9055	28	1.1024	0.079	3.704	4.019	5.555
BL317	85	3.3465	180	7.0866	41	1.6142	0.099	3.861	4.354	6.580
BL218	90	3.5433	160	6.2992	30	1.1811	0.079	3.901	4.236	5.949
BL318	90	3.5433	190	7.4803	43	1.6929	0.099	4.058	4.610	6.974
BL219	95	3.7402	170	6.6929	32	1.2598	0.079	4.176	4.492	6.265
BL319	95	3.7402	200	7.8740	45	1.7717	0.099	4.255	4.886	7.368
BL220	100	3.9370	180	7.0866	34	1.3386	0.079	4.373	4.787	6.659
BL221	105	4.1339	190	7.4803	36	1.4173	0.079	4.570	5.024	7.053

*Maximum fillet which corner radius of bearing will clear.

Note: Limiting speeds are lower with contact seals. For more information, contact NSK Engineering.

Application Data

Radial Internal Clearance — Table 10.35 page 330
 Bearing Tolerances — Table 10.12 thru Table 10.16 pages 314-17
 Snap Ring Dimensions — Table 10.9 page 310
 Shaft & Housing Fits — Table 10.31 and Table 10.33 pages 328-29

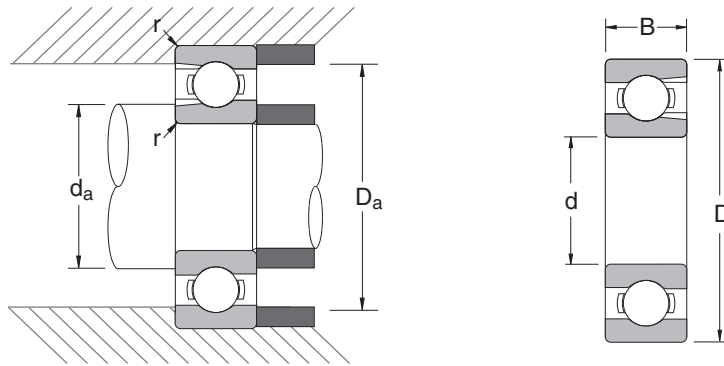

Common Options	
Z	: One Shield
ZZ	: Two Shields
NR	: Snap Ring
CO†	: Normal Internal Clearance
C3	: Greater Than Normal
† Not shown in part number	

Bearing Number	Basic Load Ratings (lbs)		Limiting Speeds (1000 RPM)		Bearing Weight (Approx.)
	C_r	C_{or}	Grease	Oil	lbs
BL205	3820	2360	13.0	15.0	0.29
BL305	5720	3470	11.0	13.0	0.54
BL206	5590	3670	11.0	13.0	0.47
BL306	7410	4650	9.5	12.0	0.80
BL207	7380	4970	9.5	11.0	0.68
BL307	9850	6540	8.5	10.0	1.07
BL208	9380	6480	8.0	10.0	0.87
BL308	12300	8040	7.5	9.0	1.47
BL209	9900	7140	7.5	9.0	0.99
BL309	14700	9910	6.7	8.0	1.94
BL210	10300	7830	7.1	8.5	1.11
BL310	17200	11800	6.0	7.5	2.51
BL211	12800	9880	6.3	7.5	1.46
BL311	19900	13800	5.6	6.7	3.23
BL212	15500	12200	5.6	7.1	1.88
BL312	22700	16100	5.3	6.3	4.07
BL213	16900	13500	5.3	6.3	2.40
BL313	27300	20200	4.8	6.0	5.10
BL214	18300	14900	5.0	6.3	2.62
BL314	30700	23000	4.5	5.3	6.23
BL215	19100	16100	4.8	5.6	2.84
BL315	33400	26000	4.3	5.0	7.44
BL216	22400	19100	4.5	5.3	3.48
BL316	36200	29200	4.0	4.8	8.89
BL217	24800	20900	4.3	5.0	4.29
BL317	39100	32600	3.8	4.5	10.36
BL218	28300	24100	4.0	4.8	5.30
BL318	42000	36200	3.6	4.3	11.84
BL219	32000	27600	3.8	4.5	6.38
BL319	45000	40000	3.0	3.6	14.08
BL220	36000	31400	3.6	4.3	7.68
BL221	39200	35300	3.4	4.0	9.20

C_r = Dynamic Radial Load Rating
 C_{or} = Static Radial Load Rating Engineering.

Note: Limiting speeds are lower with contact seals. For more information, contact NSK Engineering.



Special Ball Bearings

Bearing Number	Bore (Inch)	O.D. (Inch)	Width (Inch)		Description
			<i>IR</i>	<i>OR</i>	
X428	0.9843	2.0472	0.354	0.472	Automotive air compressor bearing
X540XL	0.9843	2.4409	0.445	0.445	Automotive air compressor bearing
40BD49VV	1.5748	2.4409	0.812	0.812	Automotive air compressor bearing (double row)
A99202-08A	0.5000	1.3750	0.438	0.438	Inch series-6202
Z9504B	0.7505	1.7805	0.615	0.615	Special bore, O.D., width-2 seals

Note: Limiting speeds are lower with contact seals. For more information, contact NSK Engineering.

Introduction

Ball Bearings

Cylindrical Roller Bearings

Spherical Roller Bearings

Tapered Roller Bearings

Thrust Bearings

Split Pillow Blocks

Super Precision Bearings

Linear Motion

Rolling Mill Bearings

Engineering Section



Integral Shaft Bearing

Bearing Number	Shaft O.D. (Inch)			D	F	X	Y	Z	H	W
	Standard		Step							
	A	B	B'							
885117	0.6267	0.6267	—	1.1811	1.531	6.375	2.297	2.547	2.328	—
885118	0.6267	0.6267	—	1.1811	1.531	4.688	1.469	1.688	1.438	—
	0.6267	0.6267	—	1.1811	1.531	5.625	1.578	2.516	—	—
885801	0.7465	0.7465	0.6267	1.5000	2.125	5.870	2.105	1.640	—	1.50
	0.7465	0.7465	—	1.5000	2.125	5.870	2.105	1.640	—	1.50
885807C	0.7465	0.7465	0.6267	1.5000	2.125	6.040	1.800	2.115	—	1.99
885586	0.6267	0.6267	—	1.1811	1.531	6.281	1.747	3.003	—	—
885801SE	0.7465	0.7465	0.6267	1.5000	2.125	5.870	2.104	1.641	—	1.50
885820	0.7465	0.7465	—	1.5000	2.125	6.625	2.000	2.500	—	—

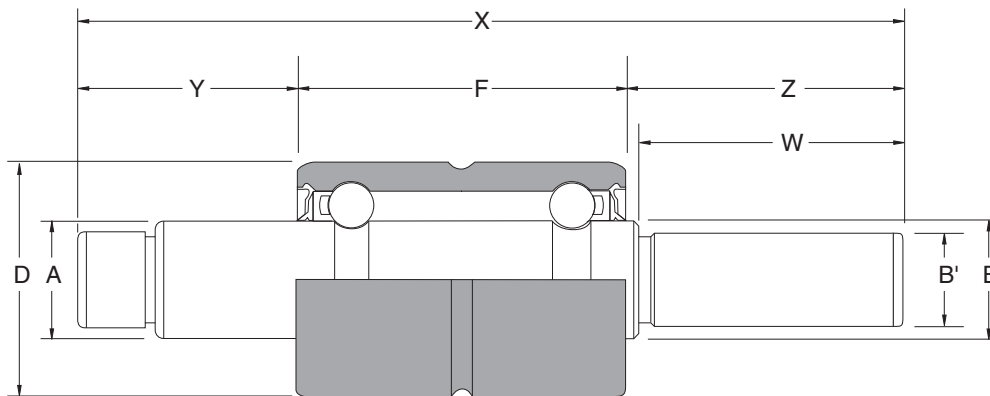

Mast Guide Bearings

Typical Applications

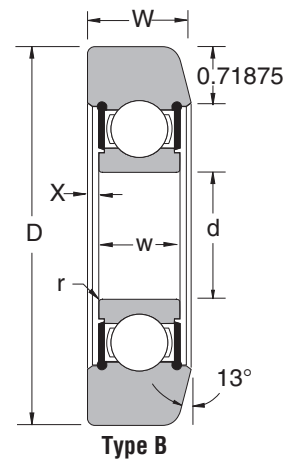
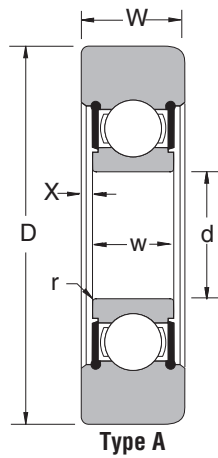
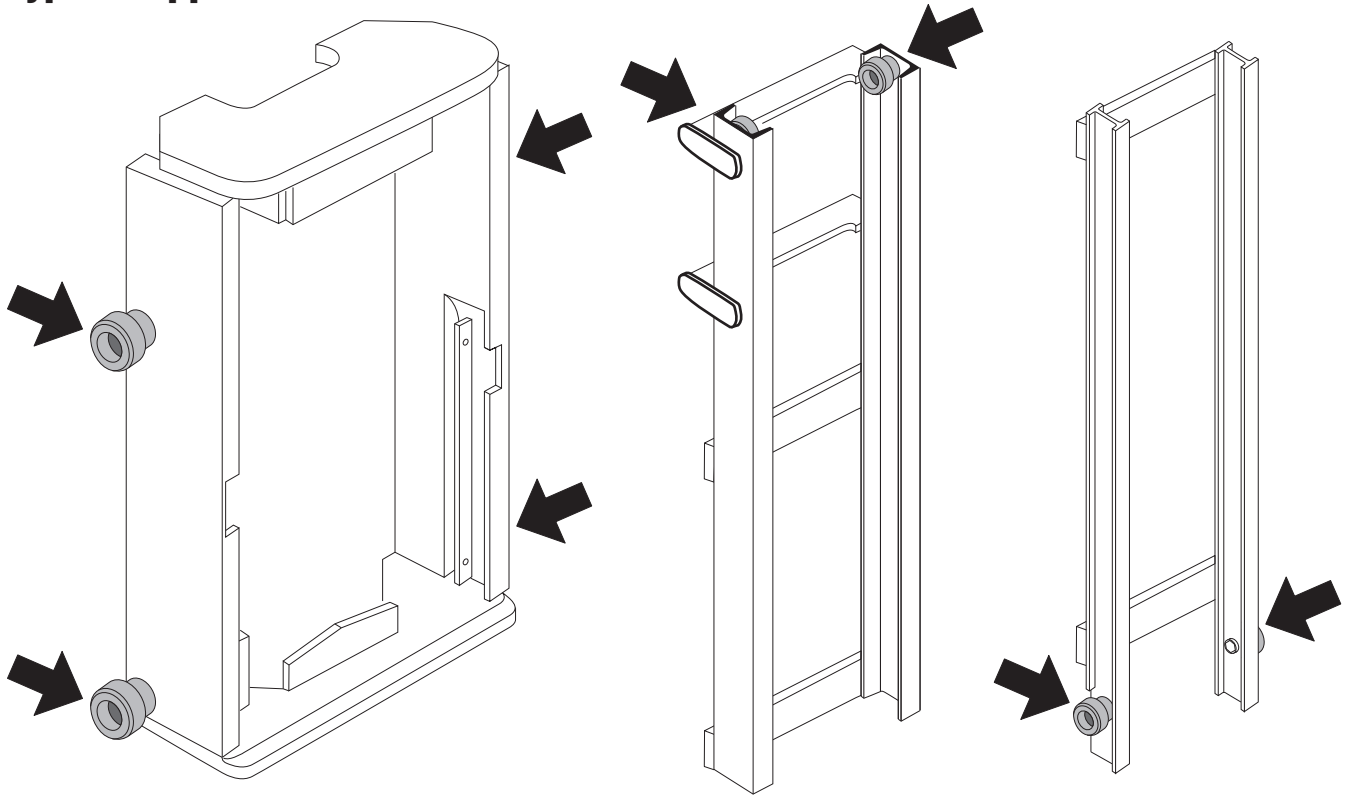

Introduction

Ball Bearings

Cylindrical Roller Bearings

Spherical Roller Bearings

Tapered Roller Bearings

Thrust Bearings

Split Pillow Blocks

Super Precision Bearings

Linear Motion

Rolling Mill Bearings

Engineering Section

Mast Guide Bearings

Dimensions

Bearing Number	Type	Bore (d)		O.D (D) inches	Outer Width (W) inches	Fillet Radius (r) inches	Ref. (X) inches
		mm	inches				
X421RS	A	25	0.9843	3.0000	1.000	1.000	0.040
X555	A	30	1.1811	3.5000	1.000	1.000	0.040
X549RS	A	35	1.3780	3.7250	1.000	1.000	0.060
X376RS	A	35	1.3780	3.9930	1.125	1.125	0.060
X501	B	45	1.7717	5.0025	1.250	1.250	0.060

Specifications

Bearing Number	Type	Dynamic Capacity (lbs)	Static Capacity (lbs)	Number of Balls	Diameter of Balls inches
X421RS	A	4630	2540	8	13/32
X555	A	6000	3370	8	15/32
X549RS	A	7500	4320	8	17/32
X376RS	A	7500	4320	8	17/32
X501	B	11900	7170	8	11/16

Interchange Table

NSK	MRC	BCA
X421RS	305SZZ3	MG305DD
X555	306SZZ5	MG306DD
X549RS	307SZZ9	MG307FFK
X376RS	307SZZ10	MG307FFH
X501	309SZZ4	MGA309DD

Table of Contents Cylindrical Roller Bearings

INTRODUCTION	
About NSK Cylindrical Roller Bearings . . .	49
NOMENCLATURE/INTERCHANGE	
Cylindrical Nomenclature	50
Cylindrical Interchange	50
APPLICATION	
Cylindrical Applications	51
BEARING TABLES	
Series 200 NU, N, NJ, NUP, NF & NH . . .	52
Series 300 NU, N, NJ, NUP, NF & NH . . .	54
Series 400 NU, N, NJ, NUP, NF & NH . . .	56
Series 1000 NU & N	58
Series 2200 NU, NJ, NUP & NH	60
Series 2300 NU, NJ, NUP & NH	62

Introduction

ABOUT NSK CYLINDRICAL ROLLER BEARINGS

- NU style single row
- N style single row
- NJ style single row
- NF style single row
- NH style single row
- NUP style single row
- Double row styles (NN, NNU)

Cylindrical roller bearings are designed to carry heavy radial loads and are suitable for high speed applications. Their rolling elements are ground to provide maximum contact with the raceway and are precisely crowned to avoid edge loading due to shaft misalignment.



NU style bearings have two machined flanges on the outer ring and no flanges on the inner ring. The rollers and cages are assembled in the outer ring. Because there are no flanges in the inner ring, this bearing cannot carry a thrust load.

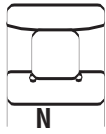

N style bearings have two machined flanges on the inner ring and no flanges on the outer ring, with rollers and cage on the inner ring. Like the NU style, the N has no thrust load carrying capability.

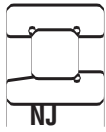

NJ style bearings have two machined flanges on the outer ring and a machined flange on one side of the inner ring. The roller and cage assembly is in the outer ring. The integral flange on the inner ring allows this bearing to carry an axial load.

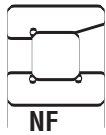

NF style bearings have two machined flanges on the inner ring and one flange on the outer ring, with roller and cage on the inner ring. Like the NJ bearing, these bearings have some thrust load capability.

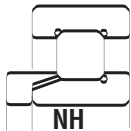

NH style bearings have two machined flanges on the outer ring and a machined flange on one side of the inner ring. A special-design inner ring allows use of a stabilizing ring on the non-flange side. As a result, these bearings can carry axial loads in both directions. The roller and cage assembly is mounted in the outer ring.



NUP style bearings are similar to the **NJ** style and come with a special ring often called a thrust collar. Mounted on the non-flange side of the inner ring, the thrust collar allows the bearing to carry an axial load in both directions. The thrust collar extends out of the bearing on one side, so the dimension across the inner ring is slightly greater than that of the outer ring.

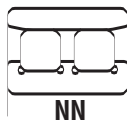

Double Row cylindrical roller bearings are denoted by two N's within the part number (e.g., **NN** or **NNU**). The dimensions for these can be found in the Super Precision section of this catalog and can be ordered with standard precision.

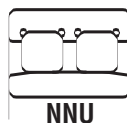

Nomenclature — Cylindrical Roller Bearings

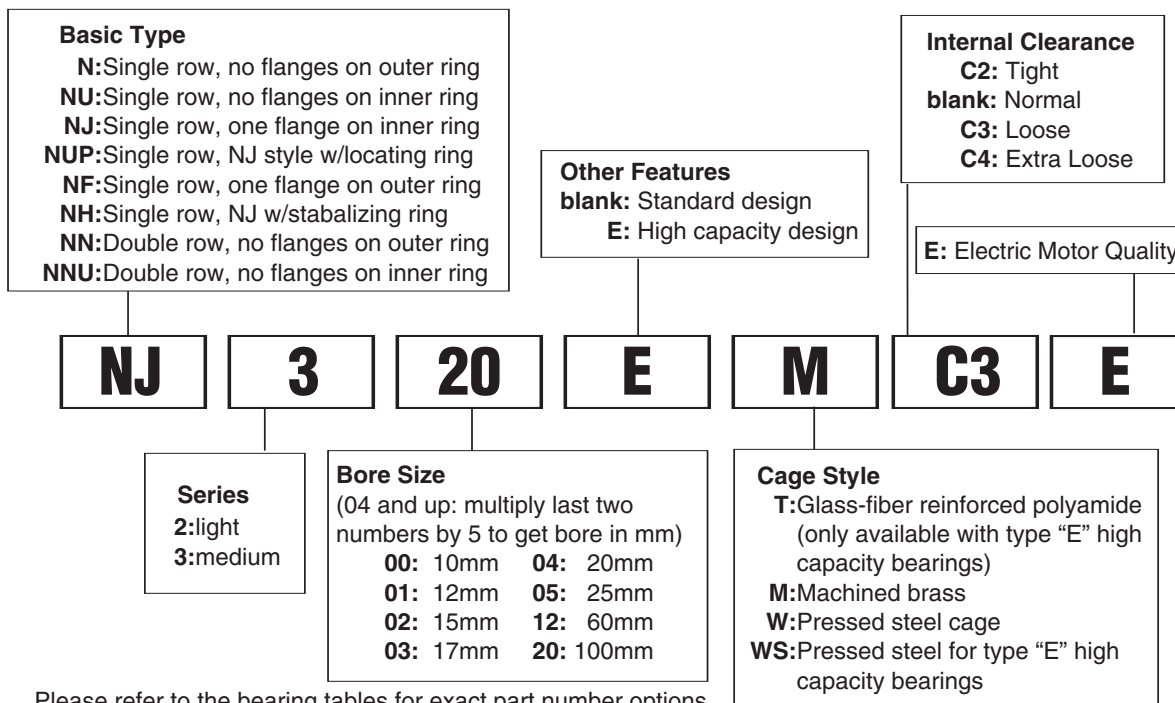

Interchange — Cylindrical Roller Bearings

DESCRIPTION		INTERCHANGE		
		NSK	SKF	FAG
Part Number Prefix	SINGLE ROW, NO FLANGES ON OUTER RING	N	N	N
	SINGLE ROW, NO FLANGES ON INNER RING	NU	NU	NU
	SINGLE ROW, 1 FLANGE INNER	NJ	NJ	NJ
	SINGLE ROW, 1 FLANGE OUTER	NF	NF	--
	SINGLE ROW, 1 FLANGE INNER, WITH RETAINING RING	NUP	NUP	NUP
	SINGLE ROW, 1 FLANGE INNER w/STABILIZING RING	NH	NH	NH
	STABILIZING RING	HJ	HJ	HJ
	DOUBLE ROW, FLANGES OUTER/FANGES INNER	NNU/NN	NNU/NN	NNU/NN
Part Number	LIGHT	2xx	2xx	2xx
	MEDIUM	3xx	3xx	3xx
	HEAVY	4xx	4xx	4xx
	EXTRA LIGHT	10xx	10xx	10xx
	LIGHT, WIDE	22xx	22xx	22xx
	MEDIUM, WIDE	23xx	23xx	23xx
Part Number Suffix	POLYAMIDE CAGE	T	P	TVP2
	COMPOSITE HIGH TEMP (200F) CAGE	T7	--	--
	MACHINED BRASS CAGE	M	M	M, M1
	PRESSED STEEL CAGE	W,WS	J	JP1
	HIGH CAPACITY DESIGN	E	EC	E
	FULL COMPLEMENT (NO CAGE)	V	V	V
	TIGHT CLEARANCE	C2	C2	C2
	NORMAL CLEARANCE	BLANK	BLANK	BLANK
	LOOSE CLEARANCE	C3	C3	C3
	EXTRA LOOSE CLEARANCE	C4	C4	C4

The competitive manufacturers are provided for a convenient source of unit substitution. They can be considered interchangeable in most instances, but for special applications, please consult NSK Engineering. NSK assumes no liability with respect to errors or omissions.

Cylindrical Roller Bearing Applications

Shown below are some common applications for cylindrical roller bearings. The bearing is designed with two flanges on one of the rings to hold the roller and cage assembly. The other ring is separable with either one flange or none at all. Designs with a flange on the separable ring can handle light axial loading against that flange. The choice of the ring configuration is determined by the mounting and assembly practices for the application. All designs have the same high radial load capacity and operate at the same limiting speeds.

Cylindrical Roller Bearings

- *Traction Motors (NH and NU)*
- *Electric Motors, medium to large size*
- *Pumps and Compressors*
 - *Centrifugal Pump*
 - *Deepwell Pump*
 - *Slurry Pump*
 - *Screw Compressor*
- *Plastic Forming Equipment*
- *Blowers and Fans*
- *Gears and Drives*
- *Coal Pulverizers (NN)*
- *Construction Equipment*
- *Heavy Equipment*
- *Machine Tool Spindle*
- *Calender Rolls of Paper Making Machines*
- *Transmissions*
- *Printing Presses*
- *Mold Oscillator Tables*
- *Continuous Casters, Float End*
- *Turbines*
- *Crushers*
- *Journal Boxes*
- *Speed Reducers*
- *Table Rollers for Steel Mills*
- *Oil Field Equipment*
 - *Pump Jack*



N Style

Cylindrical Roller Bearing

200 Series

NU, N, NJ, NUP, NF, NH and HJ Stabilizing Rings

Bearing Number		Nominal Bearing Dimensions						Preferred Shoulder Diameters (for shoulders that contact flanged rings)		
		<i>d</i>		<i>D</i>		<i>B</i>		<i>r_a</i> * (in)	<i>da</i> (in)	<i>Da</i> (in)
Prefix	Series	mm	inch	mm	inch	mm	inch	max	min	max
ADD PREFIX NU, N, NJ, NUP, NF OR NH FOR REQUIRED STYLE	205	25	0.9843	52	2.0472	15	0.5906	0.039	1.181	1.850
	206	30	1.1811	62	2.4409	16	0.6299	0.039	1.380	2.244
	207	35	1.3780	72	2.8346	17	0.6693	0.039	1.575	2.579
	208	40	1.5748	80	3.1496	18	0.7087	0.039	1.850	2.894
	209	45	1.7717	85	3.3465	19	0.7480	0.039	2.047	3.091
	210	50	1.9685	90	3.5433	20	0.7874	0.039	2.244	3.287
	211	55	2.1654	100	3.9370	21	0.8268	0.059	2.441	3.622
	212	60	2.3622	110	4.3307	22	0.8661	0.059	2.697	4.016
	213	65	2.5591	120	4.7244	23	0.9055	0.059	2.894	4.409
	214	70	2.7559	125	4.9213	24	0.9449	0.059	3.091	4.606
	215	75	2.9528	130	5.1181	25	0.9843	0.059	3.287	4.803
	216	80	3.1496	140	5.5118	26	1.0236	0.079	3.543	5.157
	217	85	3.3465	150	5.9055	28	1.1024	0.079	3.740	5.551
	218	90	3.5433	160	6.2992	30	1.1811	0.079	3.937	5.945
	219	95	3.7402	170	6.6929	32	1.2598	0.079	4.213	6.260
	220	100	3.9370	180	7.0866	34	1.3386	0.079	4.409	6.654
	221	105	4.1339	190	7.4803	36	1.4173	0.079	4.606	7.047
	222	110	4.3307	200	7.8740	38	1.4961	0.079	4.803	7.441
	224	120	4.7244	215	8.4646	40	1.5748	0.079	5.197	8.031
	226	130	5.1181	230	9.0551	40	1.5748	0.099	5.669	8.543
	228	140	5.5118	250	9.8425	42	1.6535	0.099	6.063	9.331
	230	150	5.9055	270	10.6299	45	1.7717	0.099	6.457	10.118
	232	160	6.2992	290	11.4173	48	1.8898	0.099	6.850	10.906
	234	170	6.6929	310	12.2047	52	2.0472	0.118	7.402	11.575
236	180	7.0866	320	12.5984	52	2.0472	0.118	7.795	11.969	
238	190	7.4803	340	13.3858	55	2.1654	0.118	8.189	12.756	
240	200	7.8740	360	14.1732	58	2.2835	0.118	9.409	13.543	
244	220	8.6614	400	15.7480	65	2.5591	0.118	10.394	15.118	
248	240	9.4488	440	17.3228	72	2.8346	0.118	11.378	16.693	
252	260	10.2362	480	18.8976	80	3.1496	0.157	12.362	18.110	
256	280	11.0236	500	19.6850	80	3.1496	0.157	13.150	18.898	
260	300	11.8110	540	21.2598	85	3.3465	0.157	14.094	20.472	

*Maximum fillet which corner radius of bearing will clear.

Application Data

- Radial Internal Clearance — Table 10.37 on page 331
- Bearing Tolerances — Table 10.12 thru Table 10.16 page 314-17
- Shaft & Housing Fits — Table 10.31 and Table 10.33 page 328-29

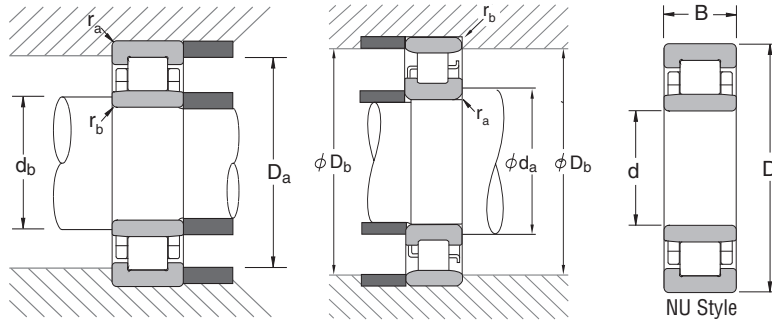

Common Options	
M	: Machined Brass Cage
W	: Pressed Steel Cage
ET	: High Capacity Polyamide Cage
C3	: Loose Internal Clearance
CO†	: Normal Internal Clearance
E	: Electric Motor Quality
† Not shown in part number	

Bearing Number		Preferred Shoulder Diameters (for shoulders that contact unflanged rings)					Basic Load Ratings (lbs)		Limiting Speeds (1000 RPM)		Bearing Weight (Approx.) lbs	Stabilizing Ring
		r _b * (in)	d _b (in)		D _b (in)							
Prefix	Series	max	min	max	min	max	C _r	C _{or}	Grease	Oil		
ADD PREFIX NU, N, NJ, NUP, NF OR NH FOR REQUIRED STYLE	205	0.024	1.142	1.181	1.811	1.890	3960	3520	13.0	16.0	0.03	HJ205
	206	0.024	1.339	1.457	2.165	2.283	5260	4840	11.0	13.0	0.47	HJ206
	207	0.024	1.535	1.654	2.480	2.677	7590	7040	9.5	11.0	0.66	HJ207
	208	0.039	1.831	1.890	2.835	2.894	9790	9570	8.5	10.0	0.85	HJ208
	209	0.039	2.028	2.087	3.031	3.091	10300	10600	7.5	9.0	0.97	HJ209
	210	0.039	2.224	2.283	3.228	3.287	10800	11400	7.1	8.5	1.10	HJ210
	211	0.039	2.421	2.520	3.583	3.681	13000	14000	6.3	7.5	1.44	HJ211
	212	0.059	2.677	2.795	3.937	4.016	15400	16800	6.0	7.1	1.85	HJ212
	213	0.059	2.874	3.031	4.252	4.409	18800	21200	5.3	6.3	2.27	HJ213
	214	0.059	3.071	3.228	4.449	4.606	18700	21300	5.0	6.3	2.54	HJ214
	215	0.059	3.268	3.386	4.685	4.803	21700	24900	4.8	6.0	2.69	HJ215
	216	0.079	3.504	3.622	5.039	5.157	23800	27500	4.5	5.3	3.40	HJ216
	217	0.079	3.701	3.898	5.394	5.551	27100	31500	4.3	5.0	4.23	HJ217
	218	0.079	3.898	4.094	5.748	5.945	34100	39800	4.0	4.8	5.18	HJ218
	219	0.079	4.173	4.370	6.102	6.260	35400	40900	3.8	4.5	6.06	HJ219
	220	0.079	4.370	4.606	6.417	6.654	40900	48800	3.6	4.3	7.50	HJ220
	221	0.079	4.567	4.843	6.772	7.047	45100	54100	3.4	4.0	8.93	HJ221
	222	0.079	4.764	5.079	7.165	7.441	51300	60900	3.2	3.8	10.30	HJ222
	224	0.079	5.157	5.512	7.717	8.031	55700	67100	3.0	3.4	12.00	HJ224
	226	0.098	5.630	5.984	8.189	8.543	58100	72600	2.6	3.2	14.00	HJ226
	228	0.098	6.024	6.496	8.858	9.331	67100	83600	2.4	3.0	18.00	HJ228
	230	0.098	6.417	6.969	9.528	10.118	77000	97900	2.2	2.8	25.00	HJ230
	232	0.098	6.811	7.480	10.276	10.906	95700	128000	2.2	2.6	32.00	HJ232
	234	0.118	7.323	7.992	10.945	11.575	107000	143000	2.0	2.4	40.00	HJ234
	236	0.118	7.717	8.386	11.339	11.969	111000	152000	1.9	2.2	42.00	HJ236
	238	0.118	8.110	8.898	12.008	12.756	124000	173000	1.8	2.2	49.00	HJ238
40	0.118	8.504	9.409	12.717	13.543	140000	195000	1.7	2.0	58.00	HJ240	
244	0.118	9.291	10.394	14.055	15.118	171000	242000	1.5	1.8	82.00	HJ244	
248	0.118	10.079	11.378	15.433	16.693	210000	299000	1.3	1.6	111.00	HJ248	
252	0.157	11.024	12.362	16.850	18.110	249000	354000	1.2	1.5	147.00	HJ252	
256	0.157	11.811	13.150	17.638	18.898	257000	376000	1.1	1.4	155.00	HJ256	
260	0.157	12.598	14.094	19.055	20.472	315000	464000	1.1	1.3	196.00	HJ260	

*Maximum fillet which corner radius of bearing will clear.

C_r = Dynamic Radial Load Rating

C_{or} = Static Radial Load Rating

Introduction

Ball Bearings

Cylindrical Roller Bearings

Spherical Roller Bearings

Tapered Roller Bearings

Thrust Bearings

Split Pillow Blocks

Super Precision Bearings

Linear Motion

Rolling Mill Bearings

Engineering Section



N Style

Cylindrical Roller Bearing

300 Series

NU, N, NJ, NUP, NF, NH and HJ Stabilizing Rings

Bearing Number		Nominal Bearing Dimensions						Preferred Shoulder Diameters (for shoulders that contact flanged rings)		
		<i>d</i>		<i>D</i>		<i>B</i>		<i>r_a</i> * (in)	<i>d_a</i> (in)	<i>D_a</i> (in)
Prefix	Series	mm	inch	mm	inch	mm	inch	max	min	max
ADD PREFIX NU, N, NJ, NUP, NF OR NH FOR REQUIRED STYLE	305	25	0.9843	62	2.4409	17	0.6693	0.039	1.240	2.185
	306	30	1.1811	72	2.8346	19	0.7480	0.039	1.437	2.579
	307	35	1.3780	80	3.1496	21	0.8268	0.059	1.693	2.835
	308	40	1.5748	90	3.5433	23	0.9055	0.059	1.890	0.126
	309	45	1.7717	100	3.9370	25	0.9843	0.059	2.087	0.142
	310	50	1.9685	110	4.3307	27	1.0630	0.079	2.323	0.155
	311	55	2.1654	120	4.7244	29	1.1417	0.079	2.520	0.171
	312	60	2.3622	130	5.1181	31	1.2205	0.079	2.795	0.183
	313	65	2.5591	140	5.5118	33	1.2992	0.079	2.992	0.198
	314	70	2.7559	150	5.9055	35	1.3780	0.079	3.189	5.433
	315	75	2.9528	160	6.2992	37	1.4567	0.079	3.386	5.827
	316	80	3.1496	170	6.6929	39	1.5354	0.079	3.583	6.220
	317	85	3.3465	180	7.0866	41	1.6142	0.099	3.858	6.535
	318	90	3.5433	190	7.4803	43	1.6929	0.099	4.055	6.929
	319	95	3.7402	200	7.8740	45	1.7717	0.099	4.252	7.323
	320	100	3.9370	215	8.4646	47	1.8504	0.099	4.449	7.913
	321	105	4.1339	225	8.8583	49	1.9291	0.099	4.646	8.307
	322	110	4.3307	240	9.4488	50	1.9685	0.099	4.843	8.898
	324	120	4.7244	260	10.2362	55	2.1654	0.099	5.236	9.685
	326	130	5.1181	280	11.0236	58	2.2835	0.118	5.748	10.315
	328	140	5.5118	300	11.8110	62	2.4409	0.118	6.142	11.102
	330	150	5.9055	320	12.5984	65	2.5591	0.118	6.535	11.890
	332	160	6.2992	340	13.3858	68	2.6772	0.118	6.929	12.677
	334	170	6.6929	360	14.1732	72	2.8346	0.118	7.323	13.543
	336	180	7.0866	380	14.9606	75	2.9528	0.118	7.717	11.969
	338	190	7.4803	400	15.7480	78	3.0709	0.157	8.268	14.961
	340	200	7.8740	420	16.5354	80	3.1496	0.157	8.661	15.748
	344	220	8.6614	460	18.1102	88	3.4646	0.157	9.449	17.323
	348	240	9.4488	500	19.6850	95	3.7402	0.157	10.236	18.898
	352	260	10.2362	540	21.2598	102	4.0157	0.197	11.260	20.236

*Maximum fillet which corner radius of bearing will clear.

Application Data

- Radial Internal Clearance — Table 10.37 on page 331
- Bearing Tolerances — Table 10.12 thru Table 10.16 page 314-17
- Shaft & Housing Fits — Table 10.31 and Table 10.33 page 328-29

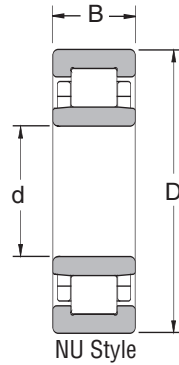
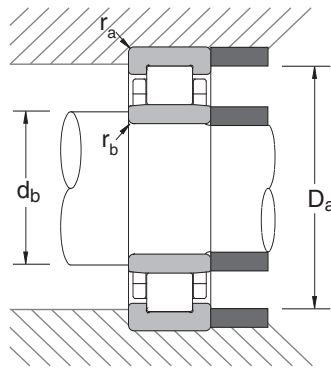

Common Options	
M	: Machined Brass Cage
W	: Pressed Steel Cage
ET	: High Capacity Polyamide Cage
C3	: Loose Internal Clearance
CO†	: Normal Internal Clearance
E	: Electric Motor Quality
† Not shown in part number	

NU Style

Bearing Number		Preferred Shoulder Diameters (for shoulders that contact unflanged rings)					Basic Load Ratings (lbs)		Limiting Speeds (1000 RPM)		Bearing Weight (Approx.) lbs	Stabilizing Ring
		r _b * (in)	d _b (in)		D _b (in)							
Prefix	Series	max	min	max	min	max	C _r	C _{or}	Grease	Oil		
ADD PREFIX NU, N, NJ, NUP, NF OR NH FOR REQUIRED STYLE.	305	0.039	1.240	1.299	2.165	2.185	6560	5650	10.0	13.0	0.53	HJ305
	306	0.039	1.437	1.575	2.520	2.520	8690	7920	8.5	11.0	0.79	HJ306
	307	0.039	1.634	1.732	2.756	2.894	11100	10600	8.0	9.5	0.99	HJ307
	308	0.059	1.890	2.008	3.110	3.228	13200	12800	6.7	8.5	1.44	HJ308
	309	0.059	2.087	2.205	3.504	3.622	16600	16000	6.3	7.5	1.94	HJ309
	310	0.079	2.323	2.480	3.819	3.819	19500	19400	5.6	6.7	2.50	HJ310
	311	0.079	2.520	2.677	4.213	4.370	24900	25100	5.0	6.3	3.20	HJ311
	312	0.079	2.795	2.953	4.528	4.685	27700	28400	4.8	5.6	4.50	HJ312
	313	0.079	2.992	3.189	4.921	5.079	30400	31200	4.3	5.3	4.90	HJ313
	314	0.079	3.189	3.425	5.236	5.472	35400	37800	4.0	5.0	6.00	HJ314
	315	0.079	3.386	3.661	5.630	5.866	40300	42500	3.8	4.8	7.10	HJ315
	316	0.079	3.583	3.937	5.906	6.260	42700	46400	3.6	4.3	8.50	HJ316
	317	0.079	3.701	4.134	6.260	6.575	47500	51300	3.4	4.0	10.00	HJ317
	318	0.098	4.055	4.409	6.614	6.969	53900	59600	3.2	3.8	12.00	HJ318
	319	0.098	4.252	4.646	6.969	7.362	58100	64900	3.0	3.6	14.00	HJ319
	320	0.098	4.449	4.961	7.480	7.953	67100	75900	2.8	3.4	17.00	HJ320
	321	0.098	4.764	5.157	7.835	8.346	71500	80300	2.6	3.2	19.00	HJ321
	322	0.098	4.843	5.472	8.307	8.937	80300	90200	2.6	3.0	22.00	HJ322
	324	0.098	5.236	5.906	9.055	9.724	101000	114000	2.2	2.8	29.00	HJ324
	326	0.118	5.748	6.417	9.724	10.394	112000	129000	2.2	2.6	35.00	HJ326
	328	0.118	6.142	6.929	10.472	11.181	123000	143000	2.0	2.4	42.00	HJ328
	330	0.118	6.535	7.402	11.142	11.969	133000	155000	1.8	2.2	58.00	HJ330
	332	0.118	6.929	7.992	11.732	12.756	156000	197000	1.7	2.0	68.00	HJ332
	334	0.118	7.323	8.465	12.441	13.543	179000	227000	1.6	2.0	82.00	HJ334
	336	0.118	7.717	8.937	13.189	14.331	202000	260000	1.5	1.8	95.00	HJ336
	338	0.157	8.268	9.449	13.858	14.961	219000	284000	1.4	1.7	109.00	HJ338
	340	0.157	8.661	10.000	14.449	15.748	219000	286000	1.3	1.6	124.00	HJ340
	344	0.157	9.449	10.945	15.866	17.323	268000	354000	1.2	1.5	165.00	HJ344
	348	0.157	10.236	11.850	17.244	18.898	306000	409000	1.1	1.3	207.00	HJ348
	352	0.197	11.260	12.992	18.583	20.236	345000	469000	1.0	1.2	257.00	HJ352

*Maximum fillet which corner radius of bearing will clear.

C_r = Dynamic Radial Load Rating
C_{or} = Static Radial Load Rating

Introduction

Ball Bearings

Cylindrical Roller Bearings

Spherical Roller Bearings

Tapered Roller Bearings

Thrust Bearings

Split Pillow Blocks

Super Precision Bearings

Linear Motion

Rolling Mill Bearings

Engineering Section



N Style

Cylindrical Roller Bearing

400 Series

NU, N, NJ, NUP, NF, NH and HJ Stabilizing Rings

Bearing Number	Nominal Bearing Dimensions						Preferred Shoulder Diameters (for shoulders that contact flanged rings)		
	<i>d</i>		<i>D</i>		<i>B</i>		<i>r_a</i> * (in)	<i>d_a</i> (in)	<i>D_a</i> (in)
Series	mm	inch	mm	inch	mm	inch	max	min	max
405	25	0.9843	80	3.1496	21	0.8268	0.059	1.299	2.835
406	30	1.1811	90	3.5433	23	0.9055	0.059	1.496	3.228
407	35	1.3780	100	3.9370	25	0.9843	0.059	1.693	3.622
408	40	1.5748	110	4.3307	27	1.0630	0.079	1.929	3.976
409	45	1.7717	120	4.7244	29	1.1417	0.079	2.126	4.370
410	50	1.9685	130	5.1181	31	1.2205	0.079	2.402	4.685
411	55	2.1654	140	5.5118	33	1.2992	0.079	2.598	5.079
412	60	2.3622	150	5.9055	35	1.3780	0.079	2.795	5.472
413	65	2.5591	160	6.2992	37	1.4567	0.039	2.992	5.866
414	70	2.7559	180	7.0866	42	1.6535	0.098	3.268	6.575
415	75	2.9528	190	7.4803	45	1.7717	0.098	3.465	6.969
416	80	3.1496	200	7.8740	48	1.8898	0.098	3.661	7.362
417	85	3.3465	210	8.2677	52	2.0472	0.118	3.976	7.638
418	90	3.5433	225	8.8583	54	2.1260	0.118	4.173	8.228
419	95	3.7402	240	9.4488	55	2.1654	0.118	4.370	8.819
420	100	3.9370	250	9.8425	58	2.2835	0.118	4.567	9.213
421	105	4.1339	260	10.2362	60	2.3622	0.118	--	9.606
422	110	4.3307	280	11.0236	65	2.5591	0.118	--	10.394
424	120	4.7244	310	12.2047	72	2.8346	0.157	5.512	11.417
426	130	5.1181	340	13.3858	78	3.0709	0.157	--	12.598
428	140	5.5118	360	14.1732	82	3.2283	0.157	6.299	13.386
430	150	5.9055	380	14.9606	85	3.3465	0.157	--	14.173

*Maximum fillet which corner radius of bearing will clear.

Application Data

- Radial Internal Clearance — Table 10.37 on page 331
- Bearing Tolerances — Table 10.12 thru Table 10.16 page 314-17
- Shaft & Housing Fits — Table 10.31 and Table 10.33 page 328-29

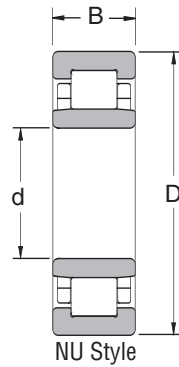
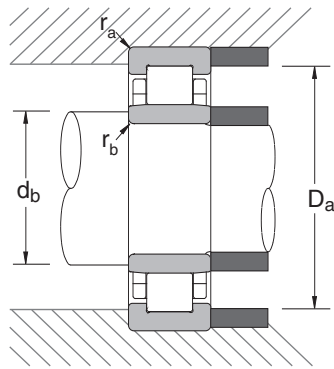

Common Options	
M	: Machined Brass Cage
W	: Pressed Steel Cage
ET	: High Capacity Polyamide Cage
C3	: Loose Internal Clearance
CO†	: Normal Internal Clearance
E	: Electric Motor Quality
† Not shown in part number	

Bearing Number		Preferred Shoulder Diameters (for shoulders that contact unflanged rings)					Basic Load Ratings (lbs)		Limiting Speeds (1000 RPM)		Bearing Weight (Approx.) lbs	Stabilizing Ring
		r_b * (in)	d_b (in)		D_b (in)							
Prefix	Series	max	min	max	min	max	C_r	C_{or}	Grease	Oil		
ADD PREFIX NU, N, NJ, NUP, NF OR NH FOR REQUIRED STYLE	405	0.059	1.299	1.457	2.520	2.835	10500	8910	9.0	11.0	1.225	HJ405
	406	0.059	1.496	1.693	2.953	3.228	14100	12300	7.5	9.5	1.632	HJ406
	407	0.059	1.693	2.008	3.346	3.622	16900	15500	6.7	8.0	2.193	HJ407
	408	0.079	1.929	2.205	3.701	3.976	21500	20000	6.0	7.5	2.794	HJ408
	409	0.079	2.126	2.441	4.055	4.370	24000	22900	5.6	6.7	3.542	HJ409
	410	0.079	2.402	2.677	4.449	4.685	29000	27700	5.0	6.0	4.312	HJ410
	411	0.079	2.598	2.953	4.685	5.079	31200	31000	4.5	5.6	5.412	HJ411
	412	0.079	2.795	3.150	5.118	5.472	37600	37800	4.3	5.3	6.60	HJ412
	413	0.079	2.992	3.386	5.433	5.866	40900	41800	4.0	4.8	7.876	HJ413
	414	0.098	3.268	3.819	6.102	6.575	51000	52800	3.6	4.3	12.00	HJ414
	415	0.098	3.465	4.016	6.457	6.969	59000	61400	3.4	4.0	14.00	HJ415
	416	0.098	3.661	4.213	6.811	7.362	67100	70400	3.2	3.8	16.00	HJ416
	417	0.118	3.976	4.331	7.087	7.638	74800	78100	3.0	3.8	21.00	HJ417
	418	0.118	4.173	4.724	7.717	8.228	83600	90200	2.8	3.4	25.00	HJ418
	419	0.118	4.370	5.118	8.110	8.740	90200	99000	2.6	3.2	30.00	HJ419
	420	0.118	4.567	5.315	8.465	9.213	100000	112000	2.6	3.0	34.00	HJ420
	421	0.118	4.764	5.551	--	--	111000	124000	2.4	3.0	38.00	HJ421
	422	0.118	4.961	5.945	--	--	123000	140000	2.2	2.8	48.00	HJ422
	424	0.157	5.512	6.535	10.472	11.417	151000	173000	2.0	2.4	66.00	HJ424
	426	0.157	5.906	7.087	--	--	185000	215000	1.8	2.2	87.00	HJ426
428	0.157	6.299	7.598	12.126	13.386	196000	229000	1.7	2.0	102.00	HJ428	
430	0.157	6.693	8.189	--	--	209000	253000	1.6	2.0	118.00	HJ430	

*Maximum fillet which corner radius of bearing will clear.

C_r = Dynamic Radial Load Rating
 C_{or} = Static Radial Load Rating



N Style

Cylindrical Roller Bearing

1000 Series
NU and N

Bearing Number		Nominal Bearing Dimensions						Preferred Shoulder Diameters (for shoulders that contact flanged rings)		
		<i>d</i>		<i>D</i>		<i>B</i>		<i>r_a</i> * (in)	<i>da</i> (in)	<i>Da</i> (in)
Prefix	Series	mm	inch	mm	inch	mm	inch	max	min	max
ADD PREFIX NU OR N FOR REQUIRED STYLE	1005	25	0.9843	47	1.8504	12	0.4724	0.024	--	1.693
	1006	30	1.1811	55	2.1654	13	0.5118	0.039	1.378	1.969
	1007	35	1.3780	62	2.4409	14	0.5512	0.039	1.575	2.244
	1008	40	1.5748	68	2.6772	15	0.5906	0.039	1.772	2.480
	1009	45	1.7717	75	2.9528	16	0.6299	0.039	1.969	2.756
	1010	50	1.9685	80	3.1496	16	0.6299	0.039	2.165	2.953
	1011	55	2.1654	90	3.5433	18	0.7087	0.039	2.421	3.287
	1012	60	2.3622	95	3.7402	18	0.7087	0.039	2.618	3.484
	1013	65	2.5591	100	3.9370	18	0.7087	0.039	2.815	3.681
	1014	70	2.7559	110	4.3307	20	0.7874	0.039	3.012	4.075
	1015	75	2.9528	115	4.5276	20	0.7874	0.039	3.209	4.272
	1016	80	3.1496	125	4.9213	22	0.8661	0.039	3.406	4.665
	1017	85	3.3465	130	5.1181	22	0.8661	0.039	3.602	4.862
	1018	90	3.5433	140	5.5118	24	0.9449	0.059	3.858	5.197
	1019	95	3.7402	145	5.7087	24	0.9449	0.059	4.055	5.394
	1020	100	3.9370	150	5.9055	24	0.9449	0.059	4.252	5.591
	1021	105	4.1339	160	6.2992	26	1.0236	0.079	4.488	5.945
	1022	110	4.3307	170	6.6929	28	1.1024	0.079	4.685	6.339
	1024	120	4.7244	180	7.0866	28	1.1024	0.079	5.079	6.732
	1026	130	5.1181	200	7.8740	33	1.2992	0.079	5.472	7.520
1028	140	5.5118	210	8.2677	33	1.2992	0.079	5.866	7.913	
1030	150	5.9055	225	8.8583	35	1.3780	0.079	6.339	8.425	
1032	160	6.2992	240	9.4488	38	1.4961	0.079	6.732	9.016	
1034	170	6.6929	260	10.2362	42	1.6535	0.079	7.126	9.803	
1036	180	7.0866	280	11.0236	46	1.8110	0.079	7.520	10.591	
1038	190	7.4803	290	11.4173	46	1.8110	0.079	7.913	10.984	
1040	200	7.8740	310	12.2047	51	2.0079	0.079	8.307	11.772	
1044	220	8.6614	340	13.3858	56	2.2047	0.098	9.173	12.874	
1048	240	9.4488	360	14.1732	56	2.2047	0.098	9.961	13.661	
1052	260	10.2362	400	15.7480	65	2.5591	0.118	10.866	14.449	
1056	280	11.0236	420	16.5354	65	2.5591	0.118	11.654	15.906	
1060	300	11.8110	460	18.1102	74	2.9134	0.118	12.441	17.480	

*Maximum fillet which corner radius of bearing will clear.

Application Data

- Radial Internal Clearance — Table 10.37 on page 331
- Bearing Tolerances — Table 10.12 thru Table 10.16 page 314-17
- Shaft & Housing Fits — Table 10.31 and Table 10.33 page 328-29

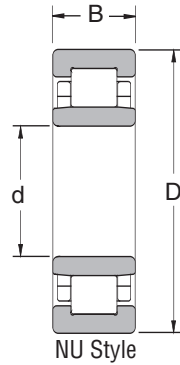
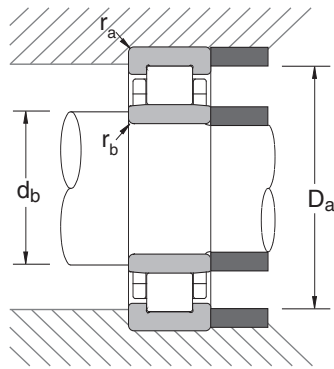

Common Options	
M	: Machined Brass Cage
W	: Pressed Steel Cage
ET	: High Capacity Polyamide Cage
C3	: Loose Internal Clearance
CO†	: Normal Internal Clearance
E	: Electric Motor Quality
† Not shown in part number	

Bearing Number		Preferred Shoulder Diameters (for shoulders that contact unflanged rings)					Basic Load Ratings (lbs)		Limiting Speeds (1000 RPM)		Bearing Weight (Approx.)
		r_b * (in)	d_b (in)		D_b (in)						
Prefix	Series	max	min	max	min	max	C_r	C_{or}	Grease	Oil	lbs
ADD PREFIX NU OR N FOR REQUIRED STYLE	1005	0.012	1.063	1.181	--	--	3210	2930	15.0	18.0	0.21
	1006	0.020	1.339	1.417	1.929	1.929	4400	4400	12.0	15.0	0.30
	1007	0.020	1.535	1.614	2.205	2.283	5080	5190	11.0	13.0	0.390
	1008	0.024	1.732	1.811	2.441	2.520	6120	6490	10.0	12.0	0.48
	1009	0.024	1.929	2.008	2.677	2.795	7260	8030	9.0	11.0	0.61
	1010	0.024	2.126	2.205	2.874	2.992	7260	8140	8.0	10.0	0.65
	1011	0.039	2.362	2.480	3.228	3.228	8470	9790	7.5	9.0	0.96
	1012	0.039	2.559	2.677	3.425	3.543	9020	10900	6.7	8.5	1.03
	1013	0.039	2.756	2.874	3.622	3.740	9240	11400	6.3	8.0	1.09
	1014	0.039	2.953	3.110	3.976	4.134	13100	15800	6.0	7.1	1.51
	1015	0.039	3.150	3.268	4.173	4.331	13400	16700	5.6	6.7	1.59
	1016	0.039	3.346	3.543	4.528	4.724	16300	20400	5.3	6.3	2.11
	1017	0.039	3.543	3.740	4.724	4.921	16700	21500	5.0	6.0	2.20
	1018	0.039	3.799	3.976	5.079	5.256	19800	25700	4.5	5.6	2.93
	1019	0.039	3.996	4.173	5.276	5.453	20400	27100	4.3	5.3	3.06
	1020	0.039	4.193	4.370	5.472	5.650	20900	28200	4.3	5.3	3.17
	1021	0.039	4.390	4.646	5.787	6.043	24400	33400	4.0	4.8	3.98
	1022	0.039	4.587	4.843	6.181	6.437	29500	38900	3.8	4.5	4.93
	1024	0.039	4.980	5.236	6.575	6.831	31000	42900	3.4	4.3	5.30
	1026	0.039	5.374	5.748	7.244	7.618	39600	52800	3.2	3.8	8.01
	1028	0.039	5.768	6.142	7.638	8.012	39400	56100	3.0	3.6	8.47
	1030	0.059	6.220	6.575	8.189	8.543	45300	65800	2.8	3.4	10.00
	1032	0.059	6.614	7.008	8.740	9.134	53200	77000	2.6	3.2	13.00
	1034	0.079	7.126	7.480	9.409	9.803	64200	93500	2.4	2.8	17.00
	1036	0.079	7.520	7.953	10.157	10.591	79200	114000	2.2	2.6	22.00
	1038	0.079	7.913	8.346	10.551	10.984	81400	120000	2.0	2.6	23.00
1040	0.079	8.307	8.898	11.181	11.772	88000	131000	2.0	2.4	31.00	
1044	0.098	9.173	9.724	12.323	12.874	112000	168000	1.8	2.2	40.00	
1048	0.098	9.961	10.472	13.110	13.661	119000	184000	1.6	2.0	43.00	
1052	0.118	10.866	11.496	14.449	15.118	144000	224000	1.5	1.8	64.00	
1056	0.118	11.654	12.283	15.236	15.906	147000	235000	1.4	1.7	67.00	
1060	0.118	12.441	13.228	16.693	17.480	198000	315000	1.3	1.5	96.00	

*Maximum fillet which corner radius of bearing will clear.

C_r = Dynamic Radial Load Rating
 C_{or} = Static Radial Load Rating

Introduction

Ball Bearings

Cylindrical Roller Bearings

Spherical Roller Bearings

Tapered Roller Bearings

Thrust Bearings

Split Pillow Blocks

Super Precision Bearings

Linear Motion

Rolling Mill Bearings

Engineering Section



N Style

Cylindrical Roller Bearing

2200 Series
NU, NJ, NUP, NH and HJ Stabilizing Rings

Bearing Number		Nominal Bearing Dimensions						Preferred Shoulder Diameters (for shoulders that contact flanged rings)		
		<i>d</i>		<i>D</i>		<i>B</i>		<i>r_a</i> * (in)	<i>d_a</i> (in)	<i>D_a</i> (in)
Prefix	Series	mm	inch	mm	inch	mm	inch	max	min	max
ADD PREFIX NU, NJ, NUP OR NH FOR REQUIRED STYLE	2205	25	0.9843	52	2.0472	18	0.7087	0.039	1.181	1.850
	2206	30	1.1811	62	2.4409	20	0.7874	0.039	1.378	2.244
	2207	35	1.3780	72	2.8346	23	0.9055	0.039	1.634	2.579
	2208	40	1.5748	80	3.1496	23	0.9055	0.039	1.831	2.894
	2209	45	1.7717	85	3.3465	23	0.9055	0.039	2.028	3.091
	2210	50	1.9685	90	3.5433	23	0.9055	0.039	2.224	3.287
	2211	55	2.1654	100	3.9370	25	0.9843	0.059	2.480	3.622
	2212	60	2.3622	110	4.3307	28	1.1024	0.059	2.677	0.047
	2213	65	2.5591	120	4.7244	31	1.2205	0.059	2.874	4.409
	2214	70	2.7559	125	4.9213	31	1.2205	0.059	3.071	4.606
	2215	75	2.9528	130	5.1181	31	1.2205	0.059	3.268	4.803
	2216	80	3.1496	140	5.5118	33	1.2992	0.079	3.504	5.157
	2217	85	3.3465	150	5.9055	36	1.4173	0.079	3.701	5.551
	2218	90	3.5433	160	6.2992	40	1.5748	0.079	3.898	5.945
	2219	95	3.7402	170	6.6929	43	1.6929	0.079	4.173	6.260
	2220	100	3.9370	180	7.0866	46	1.8110	0.079	4.370	6.654
	2222	110	4.3307	200	7.8740	53	2.0866	0.079	4.764	7.441
	2224	120	4.7244	215	8.4646	58	2.2835	0.079	5.157	8.031
	2226	130	5.1181	230	9.0551	64	2.5197	0.098	5.630	8.543
	2228	140	5.5118	250	9.8425	68	2.6772	0.098	6.024	9.331
	2230	150	5.9055	270	10.6299	73	2.8740	0.098	6.417	10.118
	2232	160	6.2992	290	11.4173	80	3.1496	0.098	6.811	10.906
	2234	170	6.6929	310	12.2047	86	3.3858	0.118	7.323	11.575
	2236	180	7.0866	320	12.5984	86	3.3858	0.118	7.717	11.969
	2238	190	7.4803	340	13.3858	92	3.6220	0.118	8.110	12.756
	2240	200	7.8740	360	14.1732	98	3.8583	0.118	8.504	13.543
	2244	220	8.6614	400	15.7480	108	4.2520	0.118	--	15.118
	2248	240	9.4488	440	17.3228	120	4.7244	0.118	--	16.693
2252	260	10.2362	480	18.8976	130	5.1181	0.157	--	18.110	

*Maximum fillet which corner radius of bearing will clear.

Application Data

- Radial Internal Clearance — Table 10.37 on page 331
- Bearing Tolerances — Table 10.12 thru Table 10.16 page 314-17
- Shaft & Housing Fits — Table 10.31 and Table 10.33 page 328-29

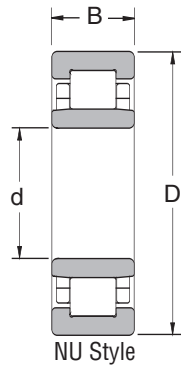
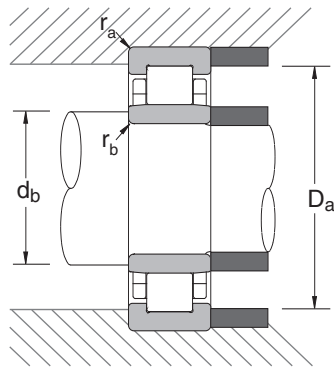

Common Options	
M	: Machined Brass Cage
W	: Pressed Steel Cage
ET	: High Capacity Polyamide Cage
C3	: Loose Internal Clearance
CO†	: Normal Internal Clearance
E	: Electric Motor Quality
† Not shown in part number	

Bearing Number		Preferred Shoulder Diameters (for shoulders that contact unflanged rings)			Basic Load Ratings (lbs)		Limiting Speeds (1000 RPM)		Bearing Weight (Approx.) lbs	Stabilizing Ring
		r_b * (in)	d_b (in)	D(in)						
Prefix	Series	max	min	This series is not available with unflanged outer rings, so only D_a is required	C_r	C_{or}	Grease	Oil		
	2205	0.024	1.142		5300	5130	12.0	14.0	0.36	HJ2205
	2206	0.024	1.339		7370	7480	10.0	12.0	0.58	HJ2206
	2207	0.024	1.535		11000	11600	8.5	10.0	0.90	HJ2207
	2208	0.039	1.831		13100	13900	7.5	9.0	1.08	HJ2208
	2209	0.039	2.028		13800	15200	7.1	8.5	1.18	HJ2209
	2210	0.039	2.224		14400	16500	6.3	8.0	1.26	HJ2210
	2211	0.039	2.421		16900	19600	6.0	7.1	1.70	HJ2211
	2212	0.059	2.677		21600	26000	5.3	6.3	2.35	HJ2212
	2213	0.059	2.874		26800	33400	4.8	6.0	3.19	HJ2213
	2214	0.059	3.071		26800	33900	4.5	5.6	3.32	HJ2214
	2215	0.059	3.268		29000	36300	4.3	5.3	3.41	HJ2215
	2216	0.079	3.504		33000	41800	4.0	5.0	4.25	HJ2216
	2217	0.079	3.701		38100	48800	3.8	4.5	5.46	HJ2217
	2218	0.079	3.898		46400	59400	3.6	4.3	6.95	HJ2218
	2219	0.079	4.173		51700	67100	3.4	4.0	8.45	HJ2219
	2220	0.079	4.370		55200	71500	3.2	3.8	10.00	HJ2220
	2222	0.079	4.764		71500	92400	2.8	3.4	15.00	HJ2222
	2224	0.079	5.157		78100	103000	2.6	3.2	18.00	HJ2224
	2226	0.098	5.630		119000	165000	2.4	3.0	23.00	HJ2226
	2228	0.098	6.024		100000	142000	2.2	2.8	29.00	HJ2228
	2230	0.098	6.417		112000	160000	2.0	2.6	37.00	HJ2230
	2232	0.098	6.811		142000	211000	1.9	2.4	63.00	HJ2232
	2234	0.118	7.323		161000	242000	1.8	2.2	64.00	HJ2234
	2236	0.118	7.717	167000	257000	1.7	2.0	67.00	HJ2236	
	2238	0.118	8.110	186000	288000	1.6	2.0	81.00	HJ2238	
	2240	0.118	8.504	207000	323000	1.5	1.8	98.00	HJ2240	
	2244	0.118	9.291	255000	405000	1.3	1.6	136.00	HJ2244	
	2248	0.118	10.079	321000	519000	1.2	1.5	186.00	HJ2248	
	2252	0.157	11.024	385000	623000	1.1	1.3	242.00	HJ2252	

*Maximum fillet which corner radius of bearing will clear.

C_r = Dynamic Radial Load Rating
 C_{or} = Static Radial Load Rating

Introduction

Ball Bearings

Cylindrical Roller Bearings

Spherical Roller Bearings

Tapered Roller Bearings

Thrust Bearings

Split Pillow Blocks

Super Precision Bearings

Linear Motion

Rolling Mill Bearings

Engineering Section



N Style

Cylindrical Roller Bearing

2300 Series

NU, NJ, NUP, NH and HJ Stabilizing Rings

Bearing Number		Nominal Bearing Dimensions						Preferred Shoulder Diameters (for shoulders that contact flanged rings)		
		<i>d</i>		<i>D</i>		<i>B</i>		<i>r_a</i> * (in)	<i>d_a</i> (in)	<i>D_a</i> (in)
Prefix	Series	mm	inch	mm	inch	mm	inch	max	min	max
ADD PREFIX NU, NJ, NUP OR NH FOR REQUIRED STYLE	2305	25	0.9843	62	2.4409	24	0.9449	0.039	1.240	2.185
	2306	30	1.1811	72	2.8346	27	1.0630	0.039	1.437	2.579
	2307	35	1.3780	80	3.1496	31	1.2205	0.059	1.693	2.835
	2308	40	1.5748	90	3.5433	33	1.2992	0.059	1.890	3.228
	2309	45	1.7717	100	3.9370	36	1.4173	0.059	2.087	3.622
	2310	50	1.9685	110	4.3307	40	1.5748	0.079	2.323	3.976
	2311	55	2.1654	120	4.7244	43	1.6929	0.079	2.520	4.370
	2312	60	2.3622	130	5.1181	46	1.8110	0.079	2.795	4.685
	2313	65	2.5591	140	5.5118	48	1.8898	0.079	2.992	5.079
	2314	70	2.7559	150	5.9055	51	2.0079	0.079	3.189	5.472
	2315	75	2.9528	160	6.2992	55	2.1654	0.079	3.386	5.866
	2316	80	3.1496	170	6.6929	58	2.2835	0.079	3.583	6.260
2317	85	3.3465	180	7.0866	60	2.3622	0.098	3.858	6.575	
2318	90	3.5433	190	7.4803	64	2.5197	0.098	4.055	6.969	
2320	100	3.9370	215	8.4646	73	2.8740	0.098	4.449	7.953	
2322	110	4.3307	240	9.4488	80	3.1496	0.098	4.843	8.937	
2324	120	4.7244	260	10.2362	86	3.3858	0.098	5.236	9.724	
2326	130	5.1181	280	11.0236	93	3.6614	0.118	5.748	10.394	
2328	140	5.5118	300	11.8110	102	4.0157	0.118	6.142	11.181	
2330	150	5.9055	320	12.5984	108	4.2520	0.118	6.535	11.969	
2332	160	6.2992	340	13.3858	114	4.4882	0.118	6.929	12.756	
2334	170	6.6929	360	14.1732	120	4.7244	0.118	7.323	13.543	
2336	180	7.0866	380	14.9606	126	4.9606	0.118	--	11.969	
2338	190	7.4803	400	15.7480	132	5.1969	0.157	--	14.961	
2340	200	7.8740	420	16.5354	138	5.4331	0.157	--	15.748	

*Maximum fillet which corner radius of bearing will clear.

Application Data

Radial Internal Clearance — Table 10.37 on page 331
 Bearing Tolerances — Table 10.12 thru Table 10.16 page 314-17
 Shaft & Housing Fits — Table 10.31 and Table 10.33 page 328-29

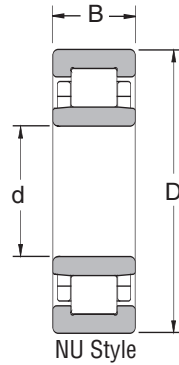
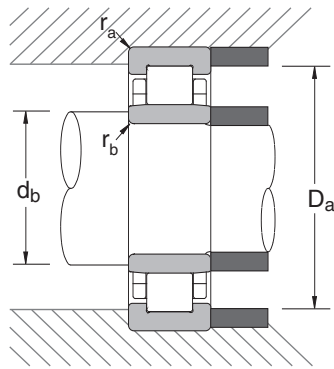

Common Options	
M	: Machined Brass Cage
W	: Pressed Steel Cage
ET	: High Capacity Polyamide Cage
C3	: Loose Internal Clearance
CO†	: Normal Internal Clearance
E	: Electric Motor Quality
† Not shown in part number	

Bearing Number		Preferred Shoulder Diameters (for shoulders that contact unflanged rings)			Basic Load Ratings (lbs)		Limiting Speeds (1000 RPM)		Bearing Weight (Approx.) lbs	Stabilizing Ring
		r_b * (in)	d_b (in)	D(in)						
Prefix	Series	max	min			C_r	C_{or}	Grease	Oil	
ADD PREFIX NU, N, NJ, NUP, NF OR NH FOR REQUIRED STYLE	2305	0.039	1.240	This series is not available with unflanged outer rings, so only D_a is required	9570	9240	9.0	11.0	0.76	HJ2305
	2306	0.039	1.437		11600	11400	7.5	9.5	1.12	HJ2306
	2307	0.039	1.634		13500	13500	7.1	8.5	1.52	HJ2307
	2308	0.059	1.890		18500	19700	6.0	7.5	2.08	HJ2308
	2309	0.059	2.087		22200	23300	5.6	6.7	2.73	HJ2309
	2310	0.079	2.323		27100	29500	5.0	6.3	3.70	HJ2310
	2311	0.079	2.520		33200	36300	4.5	5.6	4.71	HJ2311
	2312	0.079	2.795		37800	42200	4.3	5.3	5.83	HJ2312
	2313	0.079	2.992		42000	47700	3.8	4.8	7.08	HJ2313
	2314	0.079	3.189		49900	58700	3.6	4.5	8.80	HJ2314
	2315	0.079	3.386		57900	68200	3.4	4.3	11.00	HJ2315
	2316	0.079	3.583		61400	74800	3.2	4.0	14.00	HJ2316
	2317	0.098	3.858		70400	85800	3.0	3.8	15.00	HJ2317
	2318	0.098	4.055		73700	88000	2.8	3.6	18.00	HJ2318
	2320	0.098	4.449		92400	113000	2.4	3.2	26.00	HJ2320
	2322	0.098	4.843		128000	164000	2.2	2.8	41.00	HJ2322
	2324	0.098	5.236		160000	206000	2.0	2.6	52.00	HJ2324
	2326	0.118	5.748		188000	253000	1.9	2.4	64.00	HJ2326
	2328	0.118	6.142		207000	280000	1.7	2.2	81.00	HJ2328
	2330	0.118	6.535		229000	315000	1.6	2.0	98.00	HJ2330
2332	0.118	6.929	240000	341000	1.5	1.9	116.00	HJ2332		
2334	0.118	7.323	275000	394000	1.4	1.8	139.00	HJ2334		
2336	0.118	7.717	310000	447000	1.3	1.7	160.00	HJ2336		
2338	0.157	8.268	341000	497000	1.3	1.6	186.00	HJ2338		
2340	0.157	8.661	339000	504000	1.2	1.5	212.00	HJ2340		

*Maximum fillet which corner radius of bearing will clear.

C_r = Dynamic Radial Load Rating
 C_{or} = Static Radial Load Rating

Introduction

Ball Bearings

Cylindrical Roller Bearings

Spherical Roller Bearings

Tapered Roller Bearings

Thrust Bearings

Split Pillow Blocks

Super Precision Bearings

Linear Motion

Rolling Mill Bearings

Engineering Section

Introduction
Ball Bearings
Cylindrical Roller Bearings
Spherical Roller Bearings
Tapered Roller Bearings
Thrust Bearings
Split Pillow Blocks
Super Precision Bearings
Linear Motion
Rolling Mill Bearings
Engineering Section

Table of Contents

Spherical Roller Bearings

INTRODUCTION	
About NSK Spherical Roller Bearings	65
NOMENCLATURE/INTERCHANGE	
Spherical Nomenclature	66
Spherical Interchange	66
Shaker Screen Interchange	67
Triple Ring Interchange	68
APPLICATION	
Spherical Applications	69
BEARING TABLES	
Series 22200	70
Series 22300	74
Series 23000	78
Series 23100	82
Series 23200	86
Series 23900	90
Series 24000	92
Series 24100	94
Shaker Screen Bearings	96
Triple Ring Bearings	99

Introduction

ABOUT NSK SPHERICAL ROLLER BEARINGS

- Spherical Roller Bearings
- Shaker Screen Bearings
- Triple Ring Bearings

Spherical Roller bearings are double row self-aligning bearings capable of carrying heavy radial loads combined with moderate thrust loads in either direction. They are extremely resistant to shock loads and their self-aligning feature allows full capacity loading despite shaft deflection.

Shaker Screen bearings are designed for vibrating applications such as screens, feeders and compactors. These are self-aligning spherical roller bearings designed to accommodate the high loads, static and dynamic misalignment characteristics, and severe environmental conditions inherent in these applications.

Triple Ring bearings are specially designed for use with controlled crown rolls used extensively in the paper industry. These high load capacity bearings provide "shaft within shaft" operation, while simplifying the surrounding structure and installation.

Nomenclature — Spherical Roller Bearings

<p>Basic Type 22200:Spherical roller, medium 22300:Spherical roller, heavy 23000:Spherical roller, very light 23100:Spherical roller, light 23200:Spherical roller, medium, wide 23900:Spherical roller, extra light 24000:Spherical roller, very light, wide 24100:Spherical roller, light, wide</p>	<p>Lubrication Features E3: Holes only,outer E4: Groove & holes,outer E7: Groove & holes,outer & inner E8: Outer ring with tapped holes in both faces for lifting + E4 feature blank: No relubrication feature</p>	<p>Other Features P52: Outer ring accuracy P53: Inner ring accuracy P55: Both ring accuracy U22: Special inspection measure S11: Inner and outer ring Heat stabilized to 200°C</p>
<p>Bore Type blank:Cylindrical bore K:1:12 Tapered bore K30:1:30 Tapered bore</p>	231 72 CAM K E4 C3 P53S11	
<p>Bore Size (multiply last two numbers by 5 to get bore in mm) 20: 100mm 48: 240mm 32: 160mm 96: 480mm 500 millimeters and larger written as : /500: 500mm /710: 710mm /630: 630mm /1000: 1000mm</p>	<p>Cage Options CAM: One piece brass cage, guide ring C,CD: Two piece steel cage guide ring EA: High capacity steel cage H: Two piece polyamide cage M: Two piece brass cage, integral guide flange</p>	<p>Internal Clearance C2: Tight blank: Normal C3: Loose C4: Extra Loose</p>

Please refer to the bearing tables for exact part number options.

Interchange — Spherical Roller Bearings

DESCRIPTION		INTERCHANGE			
		NSK	SKF	TORR/FAF	FAG
Part Number	VERY LIGHT	239xx	239xx	239xx	239xx
	LIGHT	230xx	230xx	230xx	230xx
	LIGHT, WIDE	240xx	240xx	240xx	240xx
	MEDIUM	231xx	231xx	231xx	231xx
	MEDIUM, WIDE	241xx	241xx	241xx	241xx
	HEAVY	222xx	222xx	222xx	222xx
	HEAVY, WIDE	232xx	232xx	232xx	232xx
	EXTRA HEAVY	213xx	213xx	213xx	213xx
	EXTRA HEAVY, WIDE	223xx	223xx	223xx	223xx
Part Number Suffix	BRONZE CAGE, ONE PIECE, GUIDE RING	CAM,AM	CA,CACM	YM	M
	BRONZE CAGE, TWO PIECE, GUIDE FLANGE	M	MC	BR	MB
	STEEL CAGE, TWO PIECE, GUIDE RING	C,CD	CJ,CC	CJ,VJ	BLANK
	POLYAMIDE CAGE, TWO PIECE	H	--	VCF	TVPB
	TAPERED BORE 1:12	K	K	K	K
	TAPERED BORE 1:30	K30	K30	K	K30
	CARBURIZED STEEL, COMPLETE BEARING	g	ECD	W40	W209
	CARBURIZED STEEL, INNER RING ONLY	g3	ECB	W40I	W209B
	LUBE GROOVE & HOLES OUTER RING	E4	W33	W33	S
	LUBE GROOVE & HOLES OUTER RING, HOLES INNER RING	E7*	W513	W33W94	SH40AB
	OUTER RING, TAPPED HOLES ONE FACE FOR LIFTING	--	W56	W45A	--
	OUTER RING, TAPPED HOLES BOTH FACES FOR LIFTING + E4 FEATURE	E8	--	--	--
	HOLES ONLY OUTER RING	E3	W20	W20	SY
	HOLES ONLY INNER RING	E5	W26	W94	H40AB
	NO RELUBE FEATURES	BLANK	BLANK	BLANK	--
	PLUGS PROVIDED FOR OUTER RING HOLES	E42	W77	W84	H40
	COMBINATION W33, W4, W31	E4P55	W507	W33W4W31	--
	COMBINATION W33, W31	E4U22	W506	W33W31	--
	COMBINATION W33, W26, W31	E7U22	W509	W33W94W31	SH40A
	OUTER RING WITH EXTRA CLOSE RUNNING ACCURACY	P52	C04	C04	T52BN
	INNER RING WITH EXTRA CLOSE RUNNING ACCURACY	P53	C02	C02	T52BE
	INNER AND OUTER RING W/EXTRA CLOSE RUNNING ACCURACY	P55	C08	C08	T52BW
	SPECIAL INSPECTION MEASURES	U22	W31	W31	--
	INNER RING AND OUTER RING HEAT STABILIZED TO 200°C	S11	S1	--	--
TIGHT CLEARANCE	C2	C2	C2	C2	
NORMAL CLEARANCE	BLANK	BLANK	BLANK	BLANK	
LOOSE CLEARANCE	C3	C3	C3	C3	
EXTRA LOOSE CLEARANCE	C4	C4	C4	C4	

The competitive manufacturers are provided for a convenient source of unit substitution. They can be considered interchangeable in most instances, but for special applications, please consult NSK Engineering. NSK assumes no liability with respect to errors or omissions.

Interchange — Shaker Screen Bearings

NSK	TOR.	SKF	FAG*
22308 HE4C4U15-VS	22308VCFW33C4	452308CACM2/W502	22308ESTVPBC4F80
22309 HE4C4U15- VS	22309VCFW33C4	452309CACM2/W502	22309ESTVPBC4F80
22310 HE4C4U15- VS	22310VCFW33C4	452310CACM2/W502	22310ESTVPBC4F80
22311 CAME4C4U15-VS	22311YMW33W800C4	452311CACM2/W502	22311ASM4C4F80
22312 CAME4C4U15-VS	22312YMW33W800C4	452312CACM2/W502	22312ASM4C4F80
22313 CAME4C4U15-VS	22313YMW33W800C4	452313CACM2/W502	22313ASM4C4F80
22314 CAME4C4U15-VS	22314YMW33W800C4	452314CACM2/W502	22314ASM4C4F80
22315 CAME4C4U15-VS	22315YMW33W800C4	452315CACM2/W502	22315ASM4C4F80
22316 CAME4C4U15-VS	22316YMW33W800C4	452316CACM2/W502	22316ASM4C4F80
22317 CAME4C4U15-VS	22317YMW33W800C4	452317CACM2/W502	22317ASM4C4F80
22318 CAME4C4U15-VS	22318YMW33W800C4	452318CACM2/W502	22318ASM4C4F80
22319 CAME4C4U15-VS	22319YMW33W800C4	452319CACM2/W502	22319ASM4C4F80
22320 CAME4C4U15-VS	22320YMW33W800C4	452320CACM2/W502	22320ASM4C4F80
22322 CAME4C4U15-VS	22322YMW33W800C4	452322CACM2/W502	22322ASM4C4F80
22324 CAME4C4U15-VS	22324YMW33W800C4	452324CACM2/W502	22324ASM4C4F80
22326 CAME4C4U15-VS	22326YMW33W800C4	452326CACM2/W502	22326ASM4C4F80
22328 CAME4C4U15-VS	22328YMW33W800C4	452328CACM2/W502	22328ASM4C4F80
22330 CAME4C4U15-VS	22330YMW33W800C4	452330CACM2/W502	22330AM4C4F80
22332 CAME4C4U15-VS	22332YMW33W800C4	452332CACM2/W502	22332AM4C4F80
22334 CAME4C4U15-VS	22334W33W800C4	452334CACM2/W502	22334AM4C4F80
22336 CAME4C4U15-VS	22336W33W800C4	452336CACM2/W502	22336AM4C4F80
22338 CAME4C4U15-VS	22338W33W800C4	452338CACM2/W502	22338AM4C4F80
22340 CAME4C4U15-VS	22340W33W800C4	452340CACM2/W502	22340AM4C4F80
23322 CAME4C4U15-VS	23322W33W800C4	453322CACM2/W502	23322ASM4C4F80
23324 CAME4C4U15-VS	23324W33W800C4	453324CACM2/W502	23324ASM4C4F80
23326 CAME4C4U15-VS	23326W33W800C4	453326CACM2/W502	23326ASM4C4F80
23328 CAME4C4U15-VS	23328W33W800C4	453328CACM2/W502	23328ASM4C4F80
23330 CAME4C4U15-VS	23330W33W800C4	453330CACM2/W502	23330ASM4C4F80
23332 CAME4C4U15-VS	23332W33W800C4	453332CACM2/W502	23332ASM4C4F80
23338 CAME4C4U15-VS	23338W33W22BRC4	453338CACM2/W502	23338ASM4C4F80
23340 CAME4C4U15-VS	23340W33W22BRC4	—	23340ASM4C4F80

* NSK bearings with "CAME4C4U15-VS" suffix may also be used in place of bearings with FAG suffix "T41A"

The competitive manufacturers are provided for a convenient source of unit substitution. They can be considered interchangeable in most instances, but for special applications, please consult NSK Engineering. NSK assumes no liability with respect to errors or omissions.

Introduction

Ball Bearings

Cylindrical Roller Bearings

Spherical Roller Bearings

Tapered Roller Bearings

Thrust Bearings

Split Pillow Blocks

Super Precision Bearings

Linear Motion

Rolling Mill Bearings

Engineering Section

Interchange — Triple Ring Bearings

NSK	SKF	FAG	TOR.
2SL180-2UPA	462825	525349	B9483G
2SL200-2UPA	462826	531033	B9484G
2SL220-2UPA	462827	527870	B9485G
2SL240-2UPA	462828	531040	B9486G
2SL260-2UPA	462606	522933	B9362G (B7362G)
2SL280-2UPA	462829	525350	B9417G
2SL300-2UPA	461619	522401	B9193G (B7193G)
2SL320-2UPA	461902	525351	B9194G
2SL340-2UPA	460924	522400	B9094G (B7094G)

The competitive manufacturers are provided for a convenient source of unit substitution. They can be considered interchangeable in most instances, but for special applications, please consult NSK Engineering. NSK assumes no liability with respect to errors or omissions.

Introduction

Ball Bearings

Cylindrical Roller Bearings

Spherical Roller Bearings

Tapered Roller Bearings

Thrust Bearings

Split Pillow Blocks

Super Precision Bearings

Linear Motion

Rolling Mill Bearings

Engineering Section

Spherical Roller Bearing Applications

Provided below are a few common applications for spherical roller bearings. The spherical roller bearing is designed to handle very heavy loads, even under misalignment or shaft deflection conditions. The spherical shape of the outer ring raceway allows the inner ring to tilt slightly relative to the outer ring without significant loss in bearing life. Spherical roller bearings can also handle axial loading in either direction and heavy shock loads.

- Continuous Casters
 - Support roll
 - Guide roll
 - Pinch roll
 - Table roll
- Other Metal Mill Equipment
- Shaker Screens and Other Vibratory Equipment
- Paper Making Equipment
 - Calender rolls
 - Dryer rolls
 - Fourdrinier
 - etc.
- Mining Equipment
 - Drag lines
 - Gyratory crushers
 - Continuous miners
 - Jaw crushers
 - etc.
- Blowers and Fans
- Rubber and Plastic Forming Equipment
 - Extruders
 - Granulators
 - etc.
- Pumps and Compressors
 - Deep well
 - Slurry
 - etc.
- Gears, Drives and Reducers
- Construction Equipment
- Oil Field Equipment
 - Pump jacks
 - Compounders
 - Derricks
 - Hoists
 - etc.
- Overhead Cranes, Crane Hooks, Hoists
- Metal Forming Equipment
- Railroad Generators and Alternators



Spherical Roller Bearings

Series 22200
Bore Diameter 30 – 90 mm
1.1811 – 3.5433 inch

Bearing Number	Nominal Bearing Dimensions						Preferred Shoulder Diameters				
	<i>d</i>		<i>D</i>		<i>B</i>		<i>r</i> * (in)	<i>da</i> (in)		<i>Da</i> (in)	
	mm	inch	mm	inch	mm	inch	max	min	max	min	max
22206HE4	30	1.1811	62	2.4409	20	0.7874	0.039	1.42	1.45	2.11	2.20
22206CE4	30	1.1811	62	2.4409	20	0.7874	0.039	1.42	1.45	2.11	2.20
22207HE4	35	1.3780	72	2.8346	23	0.9055	0.039	1.65	1.69	2.46	2.56
22207CE4	35	1.3780	72	2.8346	23	0.9055	0.039	1.65	1.69	2.46	2.56
22208HE4	40	1.5748	80	3.1496	23	0.9055	0.039	1.85	1.89	2.76	2.87
22208EAE4	40	1.5748	80	3.1496	23	0.9055	0.039	1.85	1.95	2.71	2.87
22209HE4	45	1.7717	85	3.3465	23	0.9055	0.039	2.05	2.12	2.96	3.07
22209EAE4	45	1.7717	85	3.3465	23	0.9055	0.039	2.05	2.15	2.92	3.07
22210HE4	50	1.9685	90	3.5433	23	0.9055	0.039	2.24	2.32	3.16	3.27
22210EAE4	50	1.9685	90	3.5433	23	0.9055	0.039	2.24	2.37	3.14	3.27
22210CAME4	50	1.9685	90	3.5433	23	0.9055	0.039	2.24	2.33	3.12	3.27
22211HE4	55	2.1654	100	3.9370	25	0.9843	0.059	2.52	2.57	3.53	3.58
22211EAE4	55	2.1654	100	3.9370	25	0.9843	0.059	2.52	2.59	3.47	3.58
22211CAME4	55	2.1654	100	3.9370	25	0.9843	0.059	2.52	2.60	3.47	3.58
22212HE4	60	2.3622	110	4.3307	28	1.1024	0.059	2.72	2.79	3.89	3.98
22212EAE4	60	2.3622	110	4.3307	28	1.1024	0.059	2.72	2.87	3.83	3.98
22212CAME4	60	2.3622	110	4.3307	28	1.1024	0.059	2.72	2.86	3.81	3.98
22213HE4	65	2.5591	120	4.7244	31	1.2205	0.059	2.91	3.10	4.22	4.37
22213EAE4	65	2.5591	120	4.7244	31	1.2205	0.059	2.91	3.17	4.17	4.37
22213CAME4	65	2.5591	120	4.7244	31	1.2205	0.059	2.91	3.12	4.14	4.37
22214HE4	70	2.7559	125	4.9213	31	1.2205	0.059	3.11	3.30	4.41	4.57
22214EAE4	70	2.7559	125	4.9213	31	1.2205	0.059	3.11	3.30	4.35	4.57
22214CAME4	70	2.7559	125	4.9213	31	1.2205	0.059	3.11	3.28	4.35	4.57
22215HE4	75	2.9528	130	5.1181	31	1.2205	0.059	3.31	3.50	4.61	4.76
22215EAE4	75	2.9528	130	5.1181	31	1.2205	0.059	3.31	3.46	4.57	4.76
22215CAME4	75	2.9528	130	5.1181	31	1.2205	0.059	3.31	3.52	4.55	4.76
22216HE4	80	3.1496	140	5.5118	33	1.2992	0.078	3.54	3.73	4.98	5.12
22216EAE4	80	3.1496	140	5.5118	33	1.2992	0.078	3.54	3.73	4.91	5.12
22216CAME4	80	3.1496	140	5.5118	33	1.2992	0.078	3.54	3.72	4.86	5.12
22217HE4	85	3.3465	150	5.9055	36	1.4173	0.078	3.74	3.91	5.31	5.51
22217EAE4	85	3.3465	150	5.9055	36	1.4173	0.078	3.74	3.99	5.27	5.51
22217CAME4	85	3.3465	150	5.9055	36	1.4173	0.078	3.74	3.98	5.24	5.51
22218HE4	90	3.5433	160	6.2992	40	1.5748	0.078	3.94	4.16	5.63	5.91
22218EAE4	90	3.5433	160	6.2992	40	1.5748	0.078	3.94	4.25	5.57	5.91
22218CAME4	90	3.5433	160	6.2992	40	1.5748	0.078	3.94	4.24	5.56	5.91

*Maximum fillet which corner radius of bearing will clear.

Application Data

Radial Internal Clearance — Table 10.39 on page 332
 Bearing Tolerances — Table 10.12 thru Table 10.16 on pages 315-17
 Shaft & Housing Fits — Table 10.31 and Table 10.33 on pages 328-29

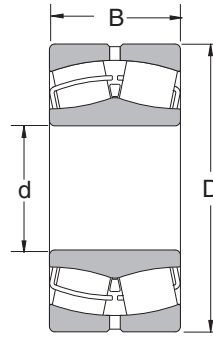
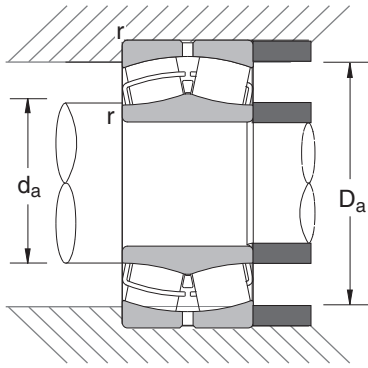

Common Options	
CAM	: One piece bronze cage
C,CD	: Two piece steel cage
EA	: High capacity steel cage
H	: Two piece polyamide cage
K	: 1:12 tapered bore
G3	: Inner ring carburized
E4	: Lube groove/holes, outer ring
P55	: High run accuracy both rings
S11	: Heat stabilized to 200°C
C2	: Tight internal clearance
C0†	: Normal internal clearance
C3	: Loose internal clearance

† Not shown in part number
See page 66 for additional options.

Bearing Number	Basic Load Ratings (lbs)		Limiting Speeds (RPM)		Bearing Weight (Approx.)
	C_r	C_{or}	Grease	Oil	lbs
22206HE4	13200	13800	6700	8500	0.55
22206CE4	11300	11200	6000	7500	0.59
22207HE4	17700	18900	5600	7100	0.85
22207CE4	15500	15900	5300	6700	0.93
22208HE4	20200	21400	5000	6300	1.03
22208EAE4	20281	22265	4800	6000	1.16
22209HE4	21300	24000	4500	6000	1.13
22209EAE4	21163	24911	4300	5300	1.25
22210HE4	22400	26200	4300	5300	1.21
22210EAE4	22200	26700	5000	6300	1.34
22210CAME4	18500	20900	4000	5000	1.28
22211HE4	27400	32000	3800	5000	1.67
22211EAE4	26700	32000	4500	5600	1.78
22211CAME4	23400	27600	3600	4500	1.79
22212HE4	33500	39000	3600	4500	2.26
22212EAE4	32000	39000	4300	5300	2.42
22212CAME4	28500	34500	3200	4000	2.48
22213HE4	39500	48500	3200	4000	3.10
22213EAE4	39500	52000	3800	4800	3.32
22213CAME4	34000	42500	3000	3800	3.34
22214HE4	41000	51500	3000	3800	3.27
22214EAE4	40500	52000	3600	4500	3.48
22214CAME4	36500	46000	2800	3600	3.49
22215HE4	42500	55500	3000	3800	3.46
22215EAE4	43000	55000	3400	4300	3.61
22215CAME4	36500	47500	2800	3400	3.73
22216HE4	48000	61500	2800	3400	4.13
22216EAE4	47500	61500	3200	4000	4.42
22216CAME4	41000	52000	2600	3200	4.47
22217HE4	56500	70500	2600	3200	5.23
22217EAE4	56000	73500	3000	3800	5.59
22217CAME4	48500	62000	2400	3000	5.62
22218HE4	66000	84000	2400	3000	6.76
22218EAE4	65000	88500	2800	3600	7.26
22218CAME4	57500	76500	2200	2800	7.33

C_r = Dynamic Radial Load Rating
 C_{or} = Static Radial Load Rating

Introduction
 Ball Bearings
 Cylindrical Roller Bearings
 Spherical Roller Bearings
 Tapered Roller Bearings
 Thrust Bearings
 Split Pillow Blocks
 Super Precision Bearings
 Linear Motion
 Rolling Mill Bearings
 Engineering Section



Spherical Roller Bearings

Series 22200 (Continued)

Bore Diameter 95 – 320 mm
3.7402 – 12.5984 inch

Bearing Number	Nominal Bearing Dimensions						Preferred Shoulder Diameters				
	<i>d</i>		<i>D</i>		<i>B</i>		<i>r</i> * (in)	<i>da</i> (in)		<i>Da</i> (in)	
	mm	inch	mm	inch	mm	inch	max	min	max	min	max
22219HE4	95	3.7402	170	6.6929	43	1.6929	0.078	4.21	4.42	5.99	6.22
22219EAE4	95	3.7402	170	6.6929	43	1.6929	0.078	4.21	4.52	5.95	6.22
22219CAME4	95	3.7402	170	6.6929	43	1.6929	0.078	4.21	4.47	5.90	6.22
22220HE4	100	3.9370	180	7.0866	46	1.8110	0.078	4.41	4.68	6.34	6.61
22220EAE4	100	3.9370	180	7.0866	46	1.8110	0.078	4.41	4.71	6.25	6.61
22220CAME4	100	3.9370	180	7.0866	46	1.8110	0.078	4.41	4.75	6.24	6.61
22222HE4	110	4.3307	200	7.8740	53	2.0866	0.078	4.80	5.15	6.98	7.40
22222EAE4	110	4.3307	200	7.8740	53	2.0866	0.078	4.80	5.11	6.95	7.40
22222CAME4	110	4.3307	200	7.8740	53	2.0866	0.078	4.80	5.26	6.91	7.40
22224HE4	120	4.7244	215	8.4646	58	2.2835	0.078	5.20	5.57	7.53	7.99
22224EAE4	120	4.7244	215	8.4646	58	2.2835	0.078	5.20	5.60	7.46	7.99
22224CAME4	120	4.7244	215	8.4646	58	2.2835	0.078	5.20	5.65	7.42	7.99
22226HE4	130	5.1181	230	9.0551	64	2.5197	0.098	5.67	5.98	8.09	8.50
22226EAE4	130	5.1181	230	9.0551	64	2.5197	0.098	5.67	6.02	8.00	8.50
22226CAME4	130	5.1181	230	9.0551	64	2.5197	0.098	5.67	6.14	7.99	8.50
22228CDE4	140	5.5118	250	9.8425	68	2.6772	0.098	6.06	6.59	8.61	9.29
22228CAME4	140	5.5118	250	9.8425	68	2.6772	0.098	6.06	6.55	8.69	9.29
22230CDE4	150	5.9055	270	10.6299	73	2.8740	0.098	6.46	7.07	9.28	10.08
22230CAME4	150	5.9055	270	10.6299	73	2.8740	0.098	6.46	7.08	9.28	10.08
22232CDE4	160	6.2992	290	11.4173	80	3.1496	0.098	6.85	7.51	10.02	10.87
22232CAME4	160	6.2992	290	11.4173	80	3.1496	0.098	6.85	7.53	10.02	10.87
22234CDE4	170	6.6929	310	12.2047	86	3.3858	0.118	7.40	8.12	10.62	11.50
22234CAME4	170	6.6929	310	12.2047	86	3.3858	0.118	7.40	8.14	10.62	11.50
22236CDE4	180	7.0866	320	12.5984	86	3.3858	0.118	7.80	8.37	10.95	11.89
22236CAME4	180	7.0866	320	12.5984	86	3.3858	0.118	7.80	8.39	10.95	11.89
22238CAME4	190	7.4803	340	13.3858	92	3.6220	0.118	8.19	8.91	11.63	12.68
22240CAME4	200	7.8740	360	14.1732	98	3.8583	0.118	8.58	9.47	12.37	13.46
22244CAME4	220	8.6614	400	15.7480	108	4.2520	0.118	9.37	10.41	13.69	15.04
22248CAME4	240	9.4488	440	17.3228	120	4.7244	0.118	10.16	11.39	15.07	16.61
22252CAME4	260	10.2362	480	18.8976	130	5.1181	0.157	11.10	12.39	16.45	18.03
22256CAME4	280	11.0236	500	19.6850	130	5.1181	0.157	11.89	13.21	17.26	18.82
22260CAME4	300	11.8110	540	21.2598	140	5.5118	0.157	12.68	14.28	18.63	20.39
22264CAME4	320	12.5984	580	22.8346	150	5.9055	0.157	13.46	15.25	19.99	21.97

*Maximum fillet which corner radius of bearing will clear.

Application Data

Radial Internal Clearance — Table 10.39 on page 332
 Bearing Tolerances — Table 10.12 thru Table 10.16 on pages 315-17
 Shaft & Housing Fits — Table 10.31 and Table 10.33 on pages 328-29

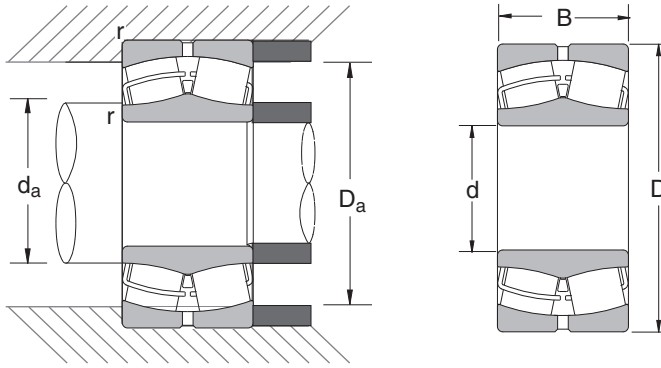

Common Options	
CAM	: One piece bronze cage
C,CD	: Two piece steel cage
EA	: High capacity steel cage
H	: Two piece polyamide cage
K	: 1:12 tapered bore
G3	: Inner ring carburized
E4	: Lube groove/holes, outer ring
P55	: High run accuracy both rings
S11	: Heat stabilized to 200°C
C2	: Tight internal clearance
C0†	: Normal internal clearance
C3	: Loose internal clearance

† Not shown in part number
See page 66 for additional options.

Bearing Number	Basic Load Ratings (lbs)		Limiting Speeds (RPM)		Bearing Weight (Approx.)
	C_r	C_{or}	Grease	Oil	lbs
22219HE4	74000	96000	2200	2800	8.27
22219EAE4	74500	101000	2600	3400	8.89
22219CAME4	66500	88500	2000	2600	8.80
22220HE4	84000	110000	2200	2600	10.06
22220EAE4	82000	110000	2400	3200	10.65
22220CAME4	74000	99000	2000	2400	10.80
22222HE4	106000	143000	1900	2400	14.76
22222EAE4	109000	145000	2200	2800	15.38
22222CAME4	95500	132000	1800	2200	15.54
22224HE4	124000	170000	1700	2200	18.42
22224EAE4	123000	172000	2000	2600	19.36
22224CAME4	110000	155000	1600	2000	19.42
22226HE4	147000	206000	1600	2000	22.89
22226EAE4	147000	211000	1900	2400	24.20
22226CAME4	127000	183000	1500	1900	24.04
22228CDE4	145000	209000	1400	1700	31.58
22228CAME4	151000	213000	1400	1700	30.47
22230CDE4	172000	252000	1300	1600	40.22
22230CAME4	172000	252000	1300	1600	39.68
22232CDE4	205000	297000	1200	1500	50.56
22232CAME4	205000	297000	1200	1500	49.20
22234CDE4	223000	335000	1100	1400	62.89
22234CAME4	223000	335000	1100	1400	61.35
22236CDE4	230000	345000	1100	1300	65.86
22236CAME4	230000	345000	1100	1300	63.97
22238CAME4	255000	390000	1000	1200	77.49
22240CAME4	292000	450000	950	1200	93.10
22244CAME4	355000	545000	850	1000	128.88
22248CAME4	420000	650000	750	950	175.32
22252CAME4	490000	760000	670	850	226.56
22256CAME4	515000	820000	630	800	238.79
22260CAME4	585000	950000	600	750	303.92
22264CAME4	675000	1100000	530	670	379.55

C_r = Dynamic Radial Load Rating
 C_{or} = Static Radial Load Rating

Introduction
 Ball Bearings
 Cylindrical Roller Bearings
 Spherical Roller Bearings
 Tapered Roller Bearings
 Thrust Bearings
 Split Pillow Blocks
 Super Precision Bearings
 Linear Motion
 Rolling Mill Bearings
 Engineering Section



Spherical Roller Bearings

Series 22300
Bore Diameter 40 – 95 mm
1.5748– 3.7402 inch

Bearing Number	Nominal Bearing Dimensions						Preferred Shoulder Diameters				
	<i>d</i>		<i>D</i>		<i>B</i>		<i>r</i> * (in)	<i>da</i> (in)		<i>Da</i> (in)	
	mm	inch	mm	inch	mm	inch	max	min	max	min	max
22308HE4	40	1.5748	90	3.5433	33	1.2992	0.059	1.93	2.06	3.03	3.19
22308EAE4	40	1.5748	90	3.5433	33	1.2992	0.059	1.93	1.95	2.96	3.19
22308CAME4	40	1.5748	90	3.5433	33	1.2992	0.059	1.93	1.96	2.96	3.19
22309HE4	45	1.7717	100	3.9370	36	1.4173	0.059	2.13	2.28	3.37	3.58
22309EAE4	45	1.7717	100	3.9370	36	1.4173	0.059	2.13	2.28	3.33	3.58
22309CAME4	45	1.7717	100	3.9370	36	1.4173	0.059	2.13	2.30	3.33	3.58
22310HE4	50	1.9685	110	4.3307	40	1.5748	0.078	2.36	2.47	3.68	3.94
22310EAE4	50	1.9685	110	4.3307	40	1.5748	0.078	2.36	2.55	3.62	3.94
22310CAME4	50	1.9685	110	4.3307	40	1.5748	0.078	2.36	2.46	3.63	3.94
22311HE4	55	2.1654	120	4.7244	43	1.6929	0.078	2.56	2.75	4.02	4.33
22311EAE4	55	2.1654	120	4.7244	43	1.6929	0.078	2.56	2.88	3.99	4.33
22311CAME4	55	2.1654	120	4.7244	43	1.6929	0.078	2.56	2.74	3.97	4.33
22312HE4	60	2.3622	130	5.1181	46	1.8110	0.078	2.83	2.93	4.35	4.65
22312EAE4	60	2.3622	130	5.1181	46	1.8110	0.078	2.83	3.11	4.32	4.65
22312CAME4	60	2.3622	130	5.1181	46	1.8110	0.078	2.83	2.97	4.30	4.65
22313HE4	65	2.5591	140	5.5118	48	1.8898	0.078	3.03	3.13	4.67	5.04
22313EAE4	65	2.5591	140	5.5118	48	1.8898	0.078	3.03	3.33	4.64	5.04
22313CAME4	65	2.5591	140	5.5118	48	1.8898	0.078	3.03	3.24	4.61	5.04
22314HE4	70	2.7559	150	5.9055	51	2.0079	0.078	3.23	3.42	5.04	5.43
22314EAE4	70	2.7559	150	5.9055	51	2.0079	0.078	3.23	3.59	5.01	5.43
22314CAME4	70	2.7559	150	5.9055	51	2.0079	0.078	3.23	3.48	4.96	5.43
22315HE4	75	2.9528	160	6.2992	55	2.1654	0.078	3.43	3.65	5.38	5.83
22315EAE4	75	2.9528	160	6.2992	55	2.1654	0.078	3.43	3.83	5.33	5.83
22315CAME4	75	2.9528	160	6.2992	55	2.1654	0.078	3.43	3.71	5.29	5.83
22316HE4	80	3.1496	170	6.6929	58	2.2835	0.078	3.62	3.86	5.71	6.22
22316EAE4	80	3.1496	170	6.6929	58	2.2835	0.078	3.62	4.07	5.66	6.22
22316CAME4	80	3.1496	170	6.6929	58	2.2835	0.078	3.62	3.94	5.64	6.22
22317HE4	85	3.3465	180	7.0866	60	2.3622	0.098	3.90	4.10	6.09	6.54
22317EAE4	85	3.3465	180	7.0866	60	2.3622	0.098	3.90	4.34	6.06	6.54
22317CAME4	85	3.3465	180	7.0866	60	2.3622	0.098	3.90	4.22	6.03	6.54
22318HE4	90	3.5433	190	7.4803	64	2.5197	0.098	4.09	4.32	6.41	6.93
22318EAE4	90	3.5433	190	7.4803	64	2.5197	0.098	4.09	4.56	6.38	6.93
22318CAME4	90	3.5433	190	7.4803	64	2.5197	0.098	4.09	4.34	6.27	6.93
22319HE4	95	3.7402	200	7.8740	67	2.6378	0.098	4.29	4.55	6.76	7.32
22319EAE4	95	3.7402	200	7.8740	67	2.6378	0.098	4.29	4.78	6.72	7.32
22319CAME4	95	3.7402	200	7.8740	67	2.6378	0.098	4.29	4.70	6.66	7.32

*Maximum fillet which corner radius of bearing will clear.

Application Data

Radial Internal Clearance — Table 10.39 on page 332
 Bearing Tolerances — Table 10.12 thru Table 10.16 on pages 315-17
 Shaft & Housing Fits — Table 10.31 and Table 10.33 on pages 328-29

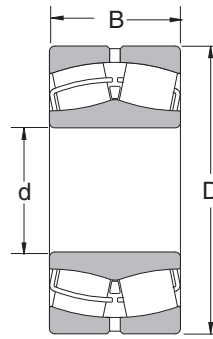
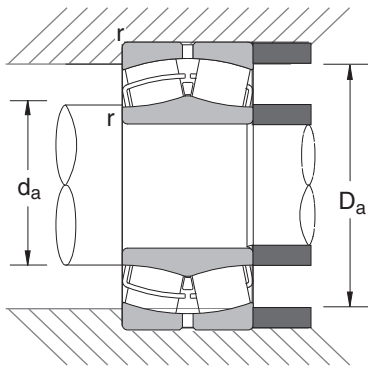

Common Options	
CAM	: One piece bronze cage
C,CD	: Two piece steel cage
EA	: High capacity steel cage
H	: Two piece polyamide cage
K	: 1:12 tapered bore
G3	: Inner ring carburized
E4	: Lube groove/holes, outer ring
P55	: High run accuracy both rings
S11	: Heat stabilized to 200°C
C2	: Tight internal clearance
C0†	: Normal internal clearance
C3	: Loose internal clearance

† Not shown in part number
See page 66 for additional options.

Bearing Number	Basic Load Ratings (lbs)		Limiting Speeds (RPM)		Bearing Weight (Approx.)
	C_r	C_{or}	Grease	Oil	lbs
22308HE4	30500	34000	4500	6000	2.09
22308EAE4	30642	34390	4300	5300	2.24
22308CAME4	27400	29100	4300	5300	2.17
22309HE4	36000	40500	4000	5300	2.79
22309EAE4	37256	43869	3800	4800	3.05
22309CAME4	33000	37500	3800	4800	2.97
22310HE4	44000	50500	3800	4800	3.67
22310EAE4	44000	52500	3800	4800	3.92
22310CAME4	41500	47500	3600	4300	3.87
22311HE4	51000	59500	3400	4300	4.71
22311EAE4	52500	65500	3400	4300	5.06
22311CAME4	47000	54500	3200	4000	4.93
22312HE4	59500	69500	3200	4000	5.92
22312EAE4	61000	77000	3200	4000	6.36
22312CAME4	55500	65000	3000	3600	6.28
22313HE4	68500	80500	3000	3800	7.31
22313EAE4	67500	85500	3000	3800	7.74
22313CAME4	59500	71500	2800	3400	7.58
22314HE4	75500	90500	2800	3400	8.76
22314EAE4	76500	97500	2800	3400	9.42
22314CAME4	69000	83500	2600	3200	9.24
22315HE4	86500	104000	2600	3200	10.78
22315EAE4	87500	113000	2600	3200	11.57
22315CAME4	76500	93000	2400	3000	11.31
22316HE4	97000	118000	2400	3000	12.87
22316EAE4	97500	128000	2400	3000	13.71
22316CAME4	87500	107000	2200	2800	13.46
22317HE4	105000	127000	2200	2800	14.64
22317EAE4	107000	141000	2200	2800	15.91
22317CAME4	93500	114000	2000	2600	15.55
22318HE4	119000	146000	2200	2600	17.57
22318EAE4	120000	158000	2200	2600	18.83
22318CAME4	109000	134000	2000	2400	18.50
22319HE4	129000	158000	2000	2600	20.23
22319EAE4	132000	175000	2000	2600	21.80
22319CAME4	118000	151000	1900	2400	21.82

C_r = Dynamic Radial Load Rating
 C_{or} = Static Radial Load Rating

Introduction

Ball Bearings

Cylindrical Roller Bearings

Spherical Roller Bearings

Tapered Roller Bearings

Thrust Bearings

Split Pillow Blocks

Super Precision Bearings

Linear Motion

Rolling Mill Bearings

Engineering Section



Spherical Roller Bearings

Series 22300 (Continued)
Bore Diameter 100 - 320 mm
3.9370 – 12.5984 inch

Bearing Number	Nominal Bearing Dimensions						Preferred Shoulder Diameters				
	<i>d</i>		<i>D</i>		<i>B</i>		<i>r</i> * (in)	<i>da</i> (in)		<i>Da</i> (in)	
	mm	inch	mm	inch	mm	inch	max	min	max	min	max
22320HE4	100	3.9370	215	8.4646	73	2.8740	0.098	4.49	5.02	7.26	7.91
22320EAE4	100	3.9370	215	8.4646	73	2.8740	0.098	4.49	5.12	7.20	7.91
22320CAME4	100	3.9370	215	8.4646	73	2.8740	0.098	4.49	5.11	7.19	7.91
22322HE4	110	4.3307	240	9.4488	80	3.1496	0.098	4.88	5.63	8.10	8.90
22322EAE4	110	4.3307	240	9.4488	80	3.1496	0.098	4.88	5.74	8.04	8.90
22322CAME4	110	4.3307	240	9.4488	80	3.1496	0.098	4.88	5.65	7.96	8.90
22324EAE4	120	4.7244	260	10.2362	86	3.3858	0.098	5.28	6.20	8.70	9.69
22324CAME4	120	4.7244	260	10.2362	86	3.3858	0.098	5.28	6.09	8.61	9.69
22326CE4	130	5.1181	280	11.0236	93	3.6614	0.118	5.83	6.54	9.28	10.31
22326CAME4	130	5.1181	280	11.0236	93	3.6614	0.118	5.83	6.57	9.28	10.31
22328CE4	140	5.5118	300	11.8110	102	4.0157	0.118	6.22	7.00	9.94	11.10
22328CAME4	140	5.5118	300	11.8110	102	4.0157	0.118	6.22	7.03	9.94	11.10
22330CAME4	150	5.9055	320	12.5984	108	4.2520	0.118	6.61	7.56	10.61	11.89
22332CAME4	160	6.2992	340	13.3858	114	4.4882	0.118	7.01	8.05	11.28	12.68
22334CAME4	170	6.6929	360	14.1732	120	4.7244	0.118	7.40	8.20	11.95	13.46
22336CAME4	180	7.0866	380	14.9606	126	4.9606	0.118	7.80	8.69	12.66	14.25
22338CAME4	190	7.4803	400	15.7480	132	5.1969	0.157	8.35	9.17	13.30	14.88
22340CAME4	200	7.8740	420	16.5354	138	5.4331	0.157	8.74	10.12	13.85	15.67
22344CAME4	220	8.6614	460	18.1102	145	5.7087	0.157	9.53	10.90	15.38	17.24
22348CAME4	240	9.4488	500	19.6850	155	6.1024	0.157	10.31	11.91	16.63	18.82
22352CAME4	260	10.2362	540	21.2598	165	6.4961	0.196	11.34	12.89	18.17	20.16
22356CAME4	280	11.0236	580	22.8346	175	6.8898	0.196	12.13	13.88	19.53	21.73
22360CAME4	300	11.8110	620	24.4094	185	7.2835	0.236	13.23	14.85	20.97	22.99
22364CAME4	320	12.5984	670	26.3780	200	7.8740	0.236	14.02	16.01	22.59	24.96

*Maximum fillet which corner radius of bearing will clear.

Application Data

Radial Internal Clearance — Table 10.39 on page 332
Bearing Tolerances — Table 10.12 thru Table 10.16 on pages 315-17
Shaft & Housing Fits — Table 10.31 and Table 10.33 on pages 328-29

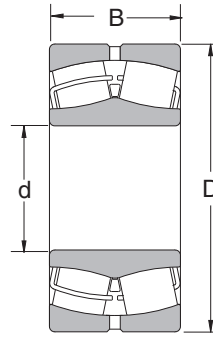
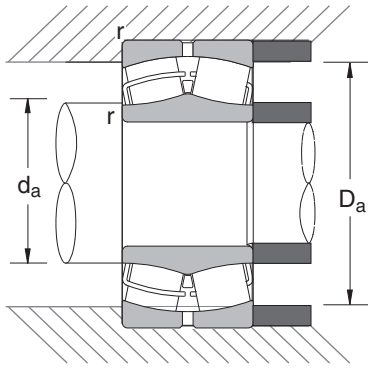

Common Options	
CAM	: One piece bronze cage
C,CD	: Two piece steel cage
EA	: High capacity steel cage
H	: Two piece polyamide cage
K	: 1:12 tapered bore
G3	: Inner ring carburized
E4	: Lube groove/holes, outer ring
P55	: High run accuracy both rings
S11	: Heat stabilized to 200°C
C2	: Tight internal clearance
C0†	: Normal internal clearance
C3	: Loose internal clearance

† Not shown in part number
See page 66 for additional options.

Bearing Number	Basic Load Ratings (lbs)		Limiting Speeds (RPM)		Bearing Weight (Approx.)
	C_r	C_{or}	Grease	Oil	lbs
22320HE4	150000	194000	1900	2400	26.52
22320EAE4	155000	209000	1900	2400	27.94
22320CAME4	135000	176000	1700	2200	27.52
22322HE4	184000	242000	1700	2200	37.11
22322EAE4	18500	253000	1700	2200	38.72
22322CAME4	166000	221000	1600	1900	38.40
22324EAE4	214000	296000	1600	2000	48.84
22324CAME4	190000	252000	1400	1800	48.30
22326CE4	223000	305000	1300	1600	61.46
22326CAME4	223000	305000	1300	1600	60.72
22328CE4	260000	360000	1200	1500	77.35
22328CAME4	260000	360000	1200	1500	75.74
22330CAME4	275000	380000	1100	1400	90.48
22332CAME4	305000	425000	1100	1300	107.65
22334CAME4	355000	475000	1000	1200	126.51
22336CAME4	390000	525000	950	1200	146.03
22338CAME4	425000	580000	900	1100	169.29
22340CAME4	450000	670000	850	1000	201.82
22344CAME4	530000	760000	750	950	253.13
22348CAME4	585000	855000	670	850	320.25
22352CAME4	700000	1030000	630	800	396.54
22356CAME4	780000	1160000	560	710	481.94
22360CAME4	885000	1320000	530	670	579.80
22364CAME4	1020000	1540000	480	600	741.39

C_r = Dynamic Radial Load Rating
 C_{or} = Static Radial Load Rating

Introduction
 Ball Bearings
 Cylindrical Roller Bearings
 Spherical Roller Bearings
 Tapered Roller Bearings
 Thrust Bearings
 Split Pillow Blocks
 Super Precision Bearings
 Linear Motion
 Rolling Mill Bearings
 Engineering Section



Spherical Roller Bearings

Series 23000
Bore Diameter 100 – 480 mm
3.9370 – 18.8976 inch

Bearing Number	Nominal Bearing Dimensions						Preferred Shoulder Diameters				
	<i>d</i>		<i>D</i>		<i>B</i>		<i>r</i> * (in)	<i>da</i> (in)		<i>Da</i> (in)	
	mm	inch	mm	inch	mm	inch	max	min	max	min	max
23020CDE4	100	3.9370	150	5.9055	37	1.4567	0.059	4.29	4.42	5.34	5.55
23022CDE4	110	4.3307	170	6.6929	45	1.7717	0.078	4.72	4.90	5.99	6.30
23022CAME4	110	4.3307	170	6.6929	45	1.7717	0.078	4.72	4.90	5.99	6.30
23024CDE4	120	4.7244	180	7.0866	46	1.8110	0.078	5.12	5.30	6.39	6.69
23024CAME4	120	4.7244	180	7.0866	46	1.8110	0.078	5.12	5.30	6.39	6.69
23026CDE4	130	5.1181	200	7.8740	52	2.0472	0.078	5.51	5.78	7.06	7.48
23026CAME4	130	5.1181	200	7.8740	52	2.0472	0.078	5.51	5.79	7.06	7.48
23028CDE4	140	5.5118	210	8.2677	53	2.0866	0.078	5.91	6.18	7.46	7.87
23028CAME4	140	5.5118	210	8.2677	53	2.0866	0.078	5.91	6.18	7.46	7.87
23030CDE4	150	5.9055	225	8.8583	56	2.2047	0.078	6.38	6.65	8.00	8.39
23030CAME4	150	5.9055	225	8.8583	56	2.2047	0.078	6.38	6.65	8.00	8.39
23032CDE4	160	6.2992	240	9.4488	60	2.3622	0.078	6.77	7.06	8.49	8.98
23032CAME4	160	6.2992	240	9.4488	60	2.3622	0.078	6.77	7.07	8.49	8.98
23034CDE4	170	6.6929	260	10.2362	67	2.6378	0.078	7.17	7.55	9.18	9.76
23034CAME4	170	6.6929	260	10.2362	67	2.6378	0.078	7.17	7.55	9.18	9.76
23036CDE4	180	7.0866	280	11.0236	74	2.9134	0.078	7.56	7.96	9.78	10.55
23036CAME4	180	7.0866	280	11.0236	74	2.9134	0.078	7.56	7.97	9.78	10.55
23038CAME4	190	7.4803	290	11.4173	75	2.9528	0.078	7.95	8.43	10.25	10.94
23040CAME4	200	7.8740	310	12.2047	82	3.2283	0.078	8.35	9.02	10.95	11.73
23044CAME4	220	8.6614	340	13.3858	90	3.5433	0.098	9.21	9.79	11.89	12.83
23048CAME4	240	9.4488	360	14.1732	92	3.6220	0.098	10.00	10.53	12.74	13.62
23052CAME4	260	10.2362	400	15.7480	104	4.0945	0.118	10.94	11.44	13.98	15.04
23056CAME4	280	11.0236	420	16.5354	106	4.1732	0.118	11.73	12.33	14.85	15.83
23060CAME4	300	11.8110	460	18.1102	118	4.6457	0.118	12.52	13.40	16.24	17.40
23064CAME4	320	12.5984	480	18.8976	121	4.7638	0.118	13.31	14.15	16.99	18.19
23068CAME4	340	13.3858	520	20.4724	133	5.2362	0.157	14.25	15.10	18.28	19.61
23072CAME4	360	14.1732	540	21.2598	134	5.2756	0.157	15.04	15.84	19.09	20.39
23076CAME4	380	14.9606	560	22.0472	135	5.3150	0.157	15.83	16.69	19.90	21.18
23080CAME4	400	15.7480	600	23.6220	148	5.8268	0.157	16.61	17.59	21.23	22.76
23084CAME4	420	16.5354	620	24.4094	150	5.9055	0.157	17.40	18.43	22.10	23.54
23088CAME4	440	17.3228	650	25.5906	157	6.1811	0.196	18.43	19.27	23.08	24.49
23092CAME4	460	18.1102	680	26.7717	163	6.4173	0.196	19.21	20.20	24.18	25.67
23096CAME4	480	18.8976	700	27.5591	165	6.4961	0.196	20.00	20.91	24.93	26.46

*Maximum fillet which corner radius of bearing will clear.

Application Data

Radial Internal Clearance — Table 10.39 on page 332
 Bearing Tolerances — Table 10.12 thru Table 10.16 on pages 315-17
 Shaft & Housing Fits — Table 10.31 and Table 10.33 on pages 328-29

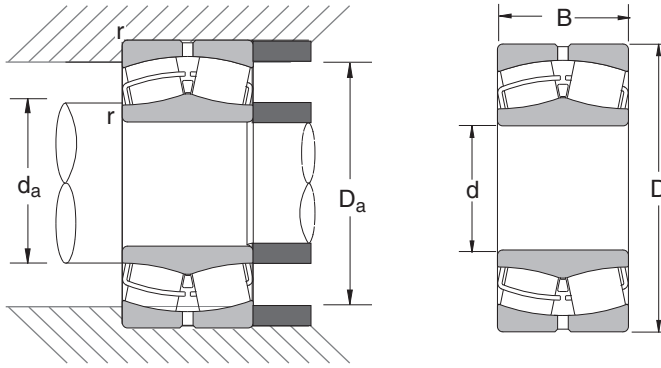

Common Options	
CAM	: One piece bronze cage
C,CD	: Two piece steel cage
EA	: High capacity steel cage
H	: Two piece polyamide cage
K	: 1:12 tapered bore
G3	: Inner ring carburized
E4	: Lube groove/holes, outer ring
P55	: High run accuracy both rings
S11	: Heat stabilized to 200°C
C2	: Tight internal clearance
CO†	: Normal internal clearance
C3	: Loose internal clearance

† Not shown in part number
See page 66 for additional options.

Bearing Number	Basic Load Ratings (lbs)		Limiting Speeds (RPM)		Bearing Weight (Approx.)
	C_r	C_{or}	Grease	Oil	lbs
23020CDE4	47500	75500	2200	2800	5.02
23022CDE4	66000	105000	2000	2400	8.18
23022CAME4	66000	105000	2000	2400	7.82
23024CDE4	70500	118000	1800	2200	8.95
23024CAME4	70500	118000	1800	2200	8.65
23026CDE4	90000	148000	1700	2000	13.00
23026CAME4	90000	148000	1700	2000	12.65
23028CDE4	94500	161000	1600	1900	14.11
23028CAME4	94500	161000	1600	1900	13.69
23030CDE4	106000	183000	1400	1800	17.19
23030CAME4	106000	183000	1400	1800	16.67
23032CDE4	121000	215000	1300	1700	21.05
23032CAME4	121000	215000	1300	1700	20.53
23034CDE4	143000	246000	1200	1600	28.29
23034CAME4	143000	246000	1200	1600	27.21
23036CDE4	168000	285000	1200	1400	37.24
23036CAME4	168000	285000	1200	1400	36.18
23038CAME4	174000	305000	1100	1400	38.45
23040CAME4	211000	385000	1000	1300	48.94
23044CAME4	245000	445000	950	1200	64.70
23048CAME4	260000	480000	850	1100	71.12
23052CAME4	320000	580000	800	950	101.63
23056CAME4	345000	665000	710	900	110.15
23060CAME4	430000	830000	670	850	154.02
23064CAME4	440000	865000	630	800	164.73
23068CAME4	510000	985000	560	710	220.55
23072CAME4	535000	1060000	530	670	230.81
23076CAME4	560000	1150000	530	630	246.15
23080CAME4	670000	1330000	480	600	318.84
23084CAME4	655000	1310000	450	560	329.35
23088CAME4	705000	1430000	430	530	378.44
23092CAME4	780000	1590000	400	500	438.48
23096CAME4	850000	1790000	400	480	461.25

C_r = Dynamic Radial Load Rating
 C_{or} = Static Radial Load Rating

Introduction
 Ball Bearings
 Cylindrical Roller Bearings
 Spherical Roller Bearings
 Tapered Roller Bearings
 Thrust Bearings
 Split Pillow Blocks
 Super Precision Bearings
 Linear Motion
 Rolling Mill Bearings
 Engineering Section



Spherical Roller Bearings

Series 23000 (Continued)
Bore Diameter 500 – 1250 mm
19.6850 – 49.2126 inch

Bearing Number	Nominal Bearing Dimensions						Preferred Shoulder Diameters				
	<i>d</i>		<i>D</i>		<i>B</i>		<i>r</i> * (in)	<i>da</i> (in)		<i>Da</i> (in)	
	mm	inch	mm	inch	mm	inch	max	min	max	min	max
230/500CAME4	500	19.6850	720	28.3465	167	6.5748	0.196	20.79	21.78	25.77	27.24
230/530CAME4	530	20.8661	780	30.7087	185	7.2835	0.196	21.97	23.25	27.78	29.61
230/560CAME4	560	22.0472	820	32.2835	195	7.6772	0.196	23.15	24.46	29.19	31.18
230/600CAME4	600	23.6220	870	34.2520	200	7.8740	0.196	24.72	26.43	31.24	33.15
230/630CAME4	630	24.8031	920	36.2205	212	8.3465	0.236	26.22	27.55	32.85	34.80
230/670CAME4	670	26.3780	980	38.5827	230	9.0551	0.236	27.80	29.39	35.08	37.17
230/710CAME4	710	27.9528	1030	40.5512	236	9.2913	0.236	29.37	31.05	36.84	39.13
230/750CAME4	750	29.5276	1090	42.9134	250	9.8425	0.236	30.94	32.78	38.97	41.50
230/800CAME4	800	31.4961	1150	45.2756	258	10.1575	0.236	32.91	34.86	41.13	43.86
230/850CAME4	850	33.4646	1220	48.0315	272	10.7087	0.236	34.88	37.03	43.65	46.61
230/900CAME4	900	35.4331	1280	50.3937	280	11.0236	0.236	36.85	39.09	46.02	48.98
230/950CAME4	950	37.4016	1360	53.5433	300	11.8110	0.236	38.82	41.37	48.83	52.13
230/1000CAME4	1000	39.3701	1420	55.9055	308	12.1260	0.236	40.79	43.42	51.10	54.49
230/1060CAME4	1060	41.7323	1500	59.0551	325	12.7953	0.314	43.46	45.95	53.84	57.32
230/1120CAME4	1120	44.0945	1580	62.2047	345	13.5827	0.314	45.83	48.46	56.83	60.47
230/1250CAME4	1250	49.2126	1750	68.8976	375	14.7638	0.314	50.94	54.11	62.94	67.17

*Maximum fillet which corner radius of bearing will clear.

Application Data

Radial Internal Clearance — Table 10.39 on page 332
Bearing Tolerances — Table 10.12 thru Table 10.16 on pages 315-17
Shaft & Housing Fits — Table 10.31 and Table 10.33 on pages 328-29

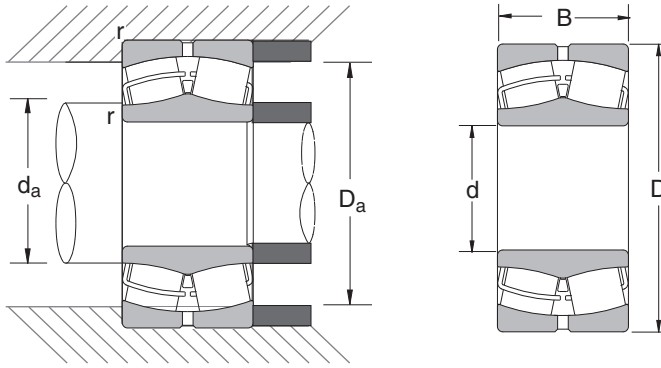

Common Options	
CAM	: One piece bronze cage
C,CD	: Two piece steel cage
EA	: High capacity steel cage
H	: Two piece polyamide cage
K	: 1:12 tapered bore
G3	: Inner ring carburized
E4	: Lube groove/holes, outer ring
P55	: High run accuracy both rings
S11	: Heat stabilized to 200°C
C2	: Tight internal clearance
C0†	: Normal internal clearance
C3	: Loose internal clearance

† Not shown in part number
See page 66 for additional options.

Bearing Number	Basic Load Ratings (lbs)		Limiting Speeds (RPM)		Bearing Weight (Approx.)
	C_r	C_{or}	Grease	Oil	lbs
230/500CAME4	850000	1820000	380	480	481
230/530CAME4	990000	2070000	340	430	652
230/560CAME4	1120000	2400000	320	400	757
230/600CAME4	1230000	2730000	300	360	856
230/630CAME4	1330000	2870000	280	340	1029
230/670CAME4	1540000	3350000	240	320	1256
230/710CAME4	1590000	3550000	240	280	1424
230/750CAME4	1740000	3850000	220	260	1689
230/800CAME4	1870000	4300000	200	240	1913
230/850CAME4	2090000	4800000	180	220	2237
230/900CAME4	2220000	5150000	160	200	2545
230/950CAME4	2550000	5950000	150	190	3091
230/1000CAME4	2680000	6300000	140	170	3440
230/1060CAME4	2930000	7050000	120	160	3928
230/1120CAME4	3450000	8550000	110	140	4674
230/1250CAME4	3900000	9950000	90	110	6086

C_r = Dynamic Radial Load Rating

C_{or} = Static Radial Load Rating

Introduction

Ball Bearings

Cylindrical Roller Bearings

Spherical Roller Bearings

Tapered Roller Bearings

Thrust Bearings

Split Pillow Blocks

Super Precision Bearings

Linear Motion

Rolling Mill Bearings

Engineering Section



Spherical Roller Bearings

Series 23100
Bore Diameter 100 – 380 mm
3.9370 – 14.9606 inch

Bearing Number	Nominal Bearing Dimensions						Preferred Shoulder Diameters				
	<i>d</i>		<i>D</i>		<i>B</i>		<i>r</i> * (in)	<i>da</i> (in)		<i>Da</i> (in)	
	mm	inch	mm	inch	mm	inch	max	min	max	min	max
23120CE4	100	3.9370	165	6.4961	52	2.0472	0.078	4.33	4.48	5.66	6.10
23120CAME4	100	3.9370	165	6.4961	52	2.0472	0.078	4.33	4.49	5.66	6.10
23122CE4	110	4.3307	180	7.0866	56	2.2047	0.078	4.72	5.02	6.19	6.69
23122CAME4	110	4.3307	180	7.0866	56	2.2047	0.078	4.72	5.03	6.19	6.69
23124CE4	120	4.7244	200	7.8740	62	2.4409	0.078	5.12	5.43	6.86	7.48
23124CAME4	120	4.7244	200	7.8740	62	2.4409	0.078	5.12	5.44	6.86	7.48
23126CE4	130	5.1181	210	8.2677	64	2.5197	0.078	5.51	5.87	7.25	7.87
23126CAME4	130	5.1181	210	8.2677	64	2.5197	0.078	5.51	5.88	7.25	7.87
23128CE4	140	5.5118	225	8.8583	68	2.6772	0.078	5.98	6.24	7.79	8.39
23128CAME4	140	5.5118	225	8.8583	68	2.6772	0.078	5.98	6.25	7.79	8.39
23130CE4	150	5.9055	250	9.8425	80	3.1496	0.078	6.38	6.85	8.57	9.37
23130CAME4	150	5.9055	250	9.8425	80	3.1496	0.078	6.38	6.86	8.57	9.37
23132CE4	160	6.2992	270	10.6299	86	3.3858	0.078	6.77	7.30	9.21	10.16
23132CAME4	160	6.2992	270	10.6299	86	3.3858	0.078	6.77	7.32	9.21	10.16
23134CE4	170	6.6929	280	11.0236	88	3.4646	0.078	7.17	7.66	9.63	10.55
23134CAME4	170	6.6929	280	11.0236	88	3.4646	0.078	7.17	7.67	9.63	10.55
23136CE4	180	7.0866	300	11.8110	96	3.7795	0.098	7.64	8.13	10.24	11.26
23136CAME4	180	7.0866	300	11.8110	96	3.7795	0.098	7.64	8.13	10.24	11.26
23138CE4	190	7.4803	320	12.5984	104	4.0945	0.098	8.03	8.64	10.84	12.05
23138CAME4	190	7.4803	320	12.5984	104	4.0945	0.098	8.03	8.64	10.84	12.05
23140CE4	200	7.8740	340	13.3858	112	4.4094	0.098	8.43	9.15	11.52	12.83
23140CAME4	200	7.8740	340	13.3858	112	4.4094	0.098	8.43	9.15	11.52	12.83
23144CE4	220	8.6614	370	14.5669	120	4.7244	0.118	9.37	10.00	12.58	13.86
23144CAME4	220	8.6614	370	14.5669	120	4.7244	0.118	9.37	9.99	12.58	13.86
23148CE4	240	9.4488	400	15.7480	128	5.0394	0.118	10.16	10.83	13.64	15.04
23148CAME4	240	9.4488	400	15.7480	128	5.0394	0.118	10.16	10.84	13.64	15.04
23152CAME4	260	10.2362	440	17.3228	144	5.6693	0.118	10.94	11.77	14.93	16.61
23156CAME4	280	11.0236	460	18.1102	146	5.7480	0.157	11.89	12.59	15.73	17.24
23160CAME4	300	11.8110	500	19.6850	160	6.2992	0.157	12.68	13.56	17.05	18.82
23164CAME4	320	12.5984	540	21.2598	176	6.9291	0.157	13.46	14.50	18.35	20.39
23168CAME4	340	13.3858	580	22.8346	190	7.4803	0.157	14.25	15.54	19.62	21.97
23172CAME4	360	14.1732	600	23.6220	192	7.5591	0.157	15.04	16.24	20.45	22.76
23176CAME4	380	14.9606	620	24.4094	194	7.6378	0.157	15.83	17.04	21.26	23.54

*Maximum fillet which corner radius of bearing will clear.

Application Data

Radial Internal Clearance — Table 10.39 on page 332
Bearing Tolerances — Table 10.12 thru Table 10.16 on pages 315-17
Shaft & Housing Fits — Table 10.31 and Table 10.33 on pages 328-29

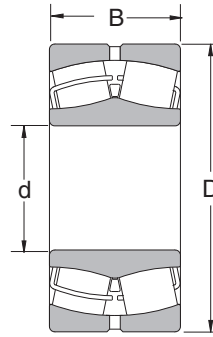
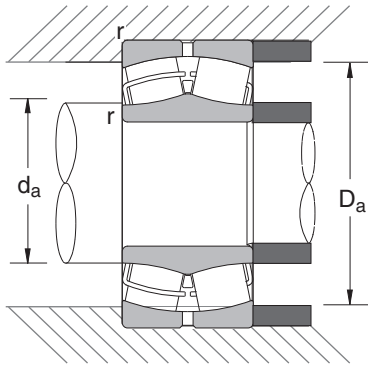

Common Options	
CAM	: One piece bronze cage
C,CD	: Two piece steel cage
EA	: High capacity steel cage
H	: Two piece polyamide cage
K	: 1:12 tapered bore
G3	: Inner ring carburized
E4	: Lube groove/holes, outer ring
P55	: High run accuracy both rings
S11	: Heat stabilized to 200°C
C2	: Tight internal clearance
CO†	: Normal internal clearance
C3	: Loose internal clearance

† Not shown in part number
See page 66 for additional options.

Bearing Number	Basic Load Ratings (lbs)		Limiting Speeds (RPM)		Bearing Weight (Approx.)
	C_r	C_{or}	Grease	Oil	lbs
23120CE4	78000	119000	1700	2200	9.52
23120CAME4	78000	119000	1700	2200	9.25
23122CE4	86500	141000	1600	2000	12.40
23122CAME4	86500	141000	1600	2000	12.03
23124CE4	105000	162000	1400	1800	17.10
23124CAME4	105000	162000	1400	1800	16.83
23126CE4	113000	186000	1300	1700	18.94
23126CAME4	113000	186000	1300	1700	18.52
23128CE4	130000	212000	1200	1600	22.92
23128CAME4	130000	212000	1200	1600	21.92
23130CE4	163000	266000	1100	1400	34.60
23130CAME4	163000	266000	1100	1400	33.83
23132CE4	192000	315000	1000	1300	44.31
23132CAME4	192000	315000	1000	1300	43.67
23134CE4	212000	355000	1000	1300	47.52
23134CAME4	212000	355000	1000	1300	45.73
23136CE4	237000	395000	900	1200	60.12
23136CAME4	237000	395000	900	1200	58.80
23138CE4	267000	455000	850	1100	75.24
23138CAME4	266000	455000	850	1100	74.15
23140CE4	305000	525000	800	1000	93.13
23140CAME4	305000	525000	800	1000	91.18
23144CE4	350000	610000	710	950	115.82
23144CAME4	350000	610000	710	950	113.64
23148CE4	400000	700000	670	850	141.82
23148CAME4	400000	700000	670	850	139.15
23152CAME4	485000	850000	600	800	192.63
23156CAME4	500000	900000	560	750	205.91
23160CAME4	600000	1080000	500	670	273.31
23164CAME4	690000	1230000	480	600	353.16
23168CAME4	810000	1480000	430	560	450.19
23172CAME4	860000	1590000	400	530	473.33
23176CAME4	895000	1700000	400	500	499.20

C_r = Dynamic Radial Load Rating
 C_{or} = Static Radial Load Rating

Introduction

Ball Bearings

Cylindrical Roller Bearings

Spherical Roller Bearings

Tapered Roller Bearings

Thrust Bearings

Split Pillow Blocks

Super Precision Bearings

Linear Motion

Rolling Mill Bearings

Engineering Section



Spherical Roller Bearings

Series 23100 (Continued)
 Bore Diameter 400 – 900 mm
 15.7480 – 35.4331 inch

Bearing Number	Nominal Bearing Dimensions						Preferred Shoulder Diameters				
	<i>d</i>		<i>D</i>		<i>B</i>		<i>r</i> * (in)	<i>da</i> (in)		<i>Da</i> (in)	
	mm	inch	mm	inch	mm	inch	max	min	max	min	max
23180CAME4	400	15.7480	650	25.5906	200	7.8740	0.196	16.85	18.00	22.37	24.49
23184CAME4	420	16.5354	700	27.5591	224	8.8189	0.196	17.64	18.98	23.89	26.46
23188CAME4	440	17.3228	720	28.3465	226	8.8976	0.196	18.43	19.75	24.67	27.24
23192CAME4	460	18.1102	760	29.9213	240	9.4488	0.236	19.53	20.72	26.01	28.50
23196CAME4	480	18.8976	790	31.1024	248	9.7638	0.236	20.31	21.58	27.07	29.69
231/500CAME4	500	19.6850	830	32.6772	264	10.3937	0.236	21.10	22.53	28.35	31.26
231/530CAME4	530	20.8661	870	34.2520	272	10.7087	0.236	22.28	23.84	29.82	32.83
231/560CAME4	560	22.0472	920	36.2205	280	11.0236	0.236	23.46	25.23	31.63	34.80
231/600CAME4	600	23.6220	980	38.5827	300	11.8110	0.236	25.04	26.97	33.69	37.17
231/630CAME4	630	24.8031	1030	40.5512	315	12.4016	0.236	26.22	28.33	35.40	39.13
231/670CAME4	670	26.3780	1090	42.9134	336	13.2283	0.236	27.80	30.03	37.45	41.50
231/710CAME4	710	27.9528	1150	45.2756	345	13.5827	0.314	29.69	31.85	39.67	43.54
231/750CAME4	750	29.5276	1220	48.0315	365	14.3701	0.314	31.26	33.81	42.07	46.30
231/800CAME4	800	31.4961	1280	50.3937	375	14.7638	0.314	33.23	35.79	44.34	48.66
231/850CAME4	850	33.4646	1360	53.5433	400	15.7480	0.393	35.59	38.13	47.08	51.42
231/900CAME4	900	35.4331	1420	55.9055	412	16.2205	0.393	37.56	39.90	49.33	53.78

*Maximum fillet which corner radius of bearing will clear.

Application Data

Radial Internal Clearance — Table 10.39 on page 332
 Bearing Tolerances — Table 10.12 thru Table 10.16 on pages 315-17
 Shaft & Housing Fits — Table 10.31 and Table 10.33 on pages 328-29

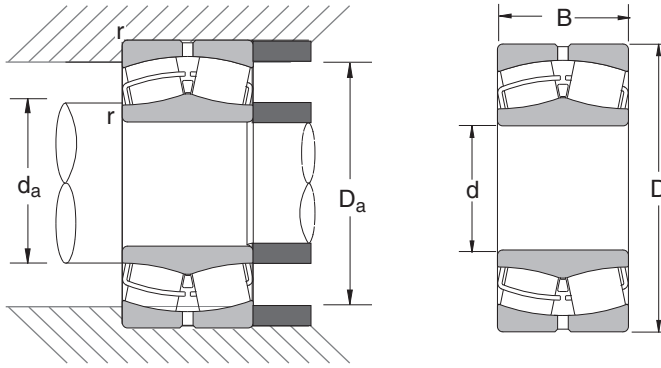

Common Options	
CAM	: One piece bronze cage
C,CD	: Two piece steel cage
EA	: High capacity steel cage
H	: Two piece polyamide cage
K	: 1:12 tapered bore
G3	: Inner ring carburized
E4	: Lube groove/holes, outer ring
P55	: High run accuracy both rings
S11	: Heat stabilized to 200°C
C2	: Tight internal clearance
C0†	: Normal internal clearance
C3	: Loose internal clearance

† Not shown in part number
See page 66 for additional options.

Bearing Number	Basic Load Ratings (lbs)		Limiting Speeds (RPM)		Bearing Weight (Approx.) lbs
	C_r	C_{or}	Grease	Oil	
23180CAME4	930000	1780000	380	480	562
23184CAME4	1120000	2110000	340	450	745
23188CAME4	1200000	2330000	320	430	788
23192CAME4	1280000	2450000	300	400	925
23196CAME4	1360000	2640000	300	380	1039
231/500CAME4	1540000	3000000	280	360	1241
231/530CAME4	1610000	3150000	260	340	1381
231/560CAME4	1760000	3500000	240	320	1600
231/600CAME4	1970000	3950000	220	280	1976
231/630CAME4	2160000	4350000	200	260	2296
231/670CAME4	2390000	4850000	190	240	2715
231/710CAME4	2660000	5500000	170	220	3114
231/750CAME4	2940000	6150000	160	200	3732
231/800CAME4	3100000	6550000	150	190	4121
231/850CAME4	3550000	7700000	130	170	4979
231/900CAME4	3850000	8300000	120	160	5469

C_r = Dynamic Radial Load Rating
 C_{or} = Static Radial Load Rating



Spherical Roller Bearings

Series 23200
Bore Diameter 70 – 280 mm
2.7559 – 11.0236 inch

Bearing Number	Nominal Bearing Dimensions						Preferred Shoulder Diameters				
	<i>d</i>		<i>D</i>		<i>B</i>		<i>r</i> * (in)	<i>da</i> (in)		<i>Da</i> (in)	
	mm	inch	mm	inch	mm	inch	max	min	max	min	max
23214CAME4	70	2.7559	125	4.9213	39.7	1.5630	0.059	3.11	3.26	4.24	4.57
23218CE4	90	3.5433	160	6.2992	52.4	2.0630	0.078	3.94	4.15	5.40	5.91
23218CAME4	90	3.5433	160	6.2992	52.4	2.0630	0.078	3.94	4.16	5.40	5.91
23219CAME4	95	3.7402	170	6.6929	55.6	2.1890	0.078	4.21	4.37	5.74	6.22
23220CE4	100	3.9370	180	7.0866	60.3	2.3740	0.078	4.41	4.67	6.09	6.61
23220CAME4	100	3.9370	180	7.0866	60.3	2.3740	0.078	4.41	4.66	6.09	6.61
23222CE4	110	4.3307	200	7.8740	69.8	2.7480	0.078	4.80	5.12	6.66	7.40
23222CAME4	110	4.3307	200	7.8740	69.8	2.7480	0.078	4.80	5.13	6.66	7.40
23224CE4	120	4.7244	215	8.4646	76	2.9921	0.078	5.20	5.52	7.16	7.99
23224CAME4	120	4.7244	215	8.4646	76	2.9921	0.078	5.20	5.54	7.16	7.99
23226CE4	130	5.1181	230	9.0551	80	3.1496	0.098	5.67	5.93	7.69	8.50
23226CAME4	130	5.1181	230	9.0551	80	3.1496	0.098	5.67	5.95	7.69	8.50
23228CE4	140	5.5118	250	9.8425	88	3.4646	0.098	6.06	6.44	8.38	9.29
23228CAME4	140	5.5118	250	9.8425	88	3.4646	0.098	6.06	6.46	8.38	9.29
23230CE4	150	5.9055	270	10.6299	96	3.7795	0.098	6.46	6.96	9.02	10.08
23230CAME4	150	5.9055	270	10.6299	96	3.7795	0.098	6.46	6.98	9.02	10.08
23232CE4	160	6.2992	290	11.4173	104	4.0945	0.098	6.85	7.44	9.62	10.87
23232CAME4	160	6.2992	290	11.4173	104	4.0945	0.098	6.85	7.47	9.62	10.87
23234CE4	170	6.6929	310	12.2047	110	4.3307	0.118	7.40	7.93	10.28	11.50
23234CAME4	170	6.6929	310	12.2047	110	4.3307	0.118	7.40	7.94	10.28	11.50
23236CE4	180	7.0866	320	12.5984	112	4.4094	0.118	7.80	8.33	10.76	11.89
23236CAME4	180	7.0866	320	12.5984	112	4.4094	0.118	7.80	8.31	10.76	11.89
23238CE4	190	7.4803	340	13.3858	120	4.7244	0.118	8.19	8.74	11.32	12.68
23238CAME4	190	7.4803	340	13.3858	120	4.7244	0.118	8.19	8.75	11.32	12.68
23240CE4	200	7.8740	360	14.1732	128	5.0394	0.118	8.58	9.34	12.08	13.46
23240CAME4	200	7.8740	360	14.1732	128	5.0394	0.118	8.58	9.35	12.08	13.46
23244CE4	220	8.6614	400	15.7480	144	5.6693	0.118	9.37	10.25	13.25	15.04
23244CAME4	220	8.6614	400	15.7480	144	5.6693	0.118	9.37	10.23	13.25	15.04
23248CAME4	240	9.4488	440	17.3228	160	6.2992	0.118	10.16	11.13	14.65	16.61
23252CAME4	260	10.2362	480	18.8976	174	6.8504	0.157	11.10	12.13	15.95	18.03
23256CAME4	280	11.0236	500	19.6850	176	6.9291	0.157	11.89	12.91	16.73	18.82

Application Data

Radial Internal Clearance — Table 10.39 on page 332
 Bearing Tolerances — Table 10.12 thru Table 10.16 on pages 315-17
 Shaft & Housing Fits — Table 10.31 and Table 10.33 on pages 328-29

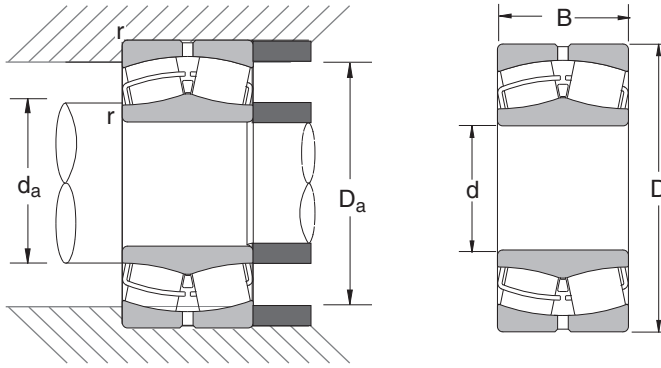

Common Options	
CAM	: One piece bronze cage
C,CD	: Two piece steel cage
EA	: High capacity steel cage
H	: Two piece polyamide cage
K	: 1:12 tapered bore
G3	: Inner ring carburized
E4	: Lube groove/holes, outer ring
P55	: High run accuracy both rings
S11	: Heat stabilized to 200°C
C2	: Tight internal clearance
CO†	: Normal internal clearance
C3	: Loose internal clearance

† Not shown in part number
See page 66 for additional options.

Bearing Number	Basic Load Ratings (lbs)		Limiting Speeds (RPM)		Bearing Weight (Approx.)
	C_r	C_{or}	Grease	Oil	lbs
23214CAME4	45500	62500	2400	3000	4.50
23218CE4	76500	110000	1800	2400	9.80
23218CAME4	76500	110000	1800	2400	9.66
23219CAME4	83000	118000	1700	2200	11.73
23220CE4	94000	135000	1600	2200	14.39
23220CAME4	94000	135000	1600	2200	14.11
23222CE4	116000	171000	1500	1900	20.78
23222CAME4	116000	171000	1500	1900	20.54
23224CE4	142000	218000	1300	1700	26.32
23224CAME4	142000	218000	1300	1700	25.67
23226CE4	158000	243000	1200	1600	31.26
23226CAME4	158000	243000	1200	1600	30.56
23228CE4	187000	292000	1100	1500	41.01
23228CAME4	187000	292000	1100	1500	40.12
23230CE4	219000	350000	1100	1400	52.72
23230CAME4	219000	350000	1100	1400	51.84
23232CE4	247000	395000	1000	1300	66.42
23232CAME4	247000	395000	1000	1300	65.57
23234CE4	270000	430000	900	1200	79.49
23234CAME4	270000	430000	900	1200	78.49
23236CE4	293000	475000	850	1100	84.97
23236CAME4	292000	475000	850	1100	81.70
23238CE4	325000	530000	800	1100	104.03
23238CAME4	325000	530000	800	1100	101.74
23240CE4	375000	620000	750	1000	124.47
23240CAME4	370000	620000	750	1000	121.20
23244CE4	455000	765000	670	900	175.45
23244CAME4	455000	765000	670	900	172.23
23248CAME4	550000	910000	630	800	231.56
23252CAME4	615000	1020000	560	750	298.14
23256CAME4	650000	1110000	530	670	319.60

C_r = Dynamic Radial Load Rating

C_{or} = Static Radial Load Rating

Introduction

Ball Bearings

Cylindrical Roller Bearings

Spherical Roller Bearings

Tapered Roller Bearings

Thrust Bearings

Split Pillow Blocks

Super Precision Bearings

Linear Motion

Rolling Mill Bearings

Engineering Section



Spherical Roller Bearings

Series 23200 (Continued)
Bore Diameter 300 – 950 mm
11.8110 - 37.4016 inch

Bearing Number	Nominal Bearing Dimensions						Preferred Shoulder Diameters				
	<i>d</i>		<i>D</i>		<i>B</i>		<i>r</i> * (in)	<i>da</i> (in)		<i>Da</i> (in)	
	mm	inch	mm	inch	mm	inch	max	min	max	min	max
23260CAME4	300	11.8110	540	21.2598	192	7.5591	0.157	12.68	13.87	18.00	20.39
23264CAME4	320	12.5984	580	22.8346	208	8.1890	0.157	13.46	14.88	19.21	21.97
23268CAME4	340	13.3858	620	24.4094	224	8.8189	0.196	14.49	15.83	20.49	23.31
23272CAME4	360	14.1732	650	25.5906	232	9.1339	0.196	15.28	16.62	21.59	24.49
23276CAME4	380	14.9606	680	26.7717	240	9.4488	0.196	16.06	17.55	22.74	25.67
23280CAME4	400	15.7480	720	28.3465	256	10.0787	0.196	16.85	18.45	23.99	27.24
23284CAME4	420	16.5354	760	29.9213	272	10.7087	0.236	17.95	19.48	25.34	28.50
23288CAME4	440	17.3228	790	31.1024	280	11.0236	0.236	18.74	20.34	26.31	29.69
23292CAME4	460	18.1102	830	32.6772	296	11.6535	0.236	19.53	21.45	27.63	31.26
23296CAME4	480	18.8976	870	34.2520	310	12.2047	0.236	20.31	22.19	28.86	32.83
232/500CAME4	500	19.6850	920	36.2205	336	13.2283	0.236	21.10	23.36	30.44	34.80
232/530CAME4	530	20.8661	980	38.5827	355	13.9764	0.314	22.60	24.81	32.41	36.85
232/560CAME4	560	22.0472	1030	40.5512	365	14.3701	0.314	23.78	26.29	34.23	38.82
232/600CAME4	600	23.6220	1090	42.9134	388	15.2756	0.314	25.35	28.07	36.32	41.18
232/630CAME4	630	24.8031	1150	45.2756	412	16.2205	0.393	26.93	29.36	38.19	43.15
232/670CAME4	670	26.3780	1220	48.0315	438	17.2441	0.393	28.50	30.94	40.32	45.91
232/710CAME4	710	27.9528	1280	50.3937	450	17.7165	0.393	30.08	32.83	42.51	48.27
232/750CAME4	750	29.5276	1360	53.5433	475	18.7008	0.472	32.05	35.14	45.17	51.02
232/800CAME4	800	31.4961	1420	55.9055	488	19.2126	0.472	34.02	36.70	47.55	53.39
232/850CAME4	850	33.4646	1500	59.0551	515	20.2756	0.472	35.98	38.86	50.16	56.54
232/950CAME4	950	37.4016	1660	65.3543	530	20.8661	0.472	39.92	43.71	56.22	62.83

Introduction

Ball Bearings

Cylindrical Roller Bearings

Spherical Roller Bearings

Tapered Roller Bearings

Thrust Bearings

Split Pillow Blocks

Super Precision Bearings

Linear Motion

Rolling Mill Bearings

Engineering Section

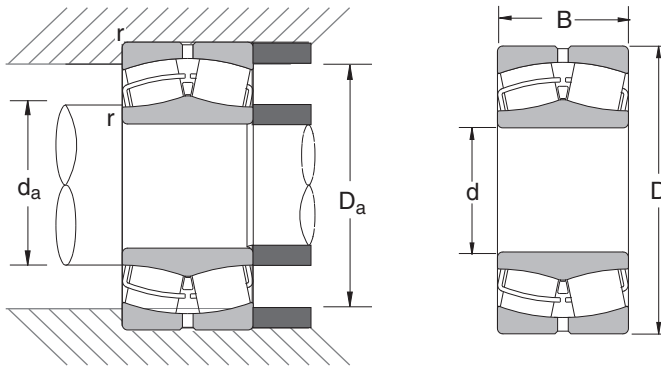

Common Options	
CAM	: One piece bronze cage
C,CD	: Two piece steel cage
EA	: High capacity steel cage
H	: Two piece polyamide cage
K	: 1:12 tapered bore
G3	: Inner ring carburized
E4	: Lube groove/holes, outer ring
P55	: High run accuracy both rings
S11	: Heat stabilized to 200°C
C2	: Tight internal clearance
CO†	: Normal internal clearance
C3	: Loose internal clearance

† Not shown in part number
See page 66 for additional options.

Bearing Number	Basic Load Ratings (lbs)		Limiting Speeds (RPM)		Bearing Weight (Approx.)
	C_r	C_{or}	Grease	Oil	lbs
23260CAME4	770000	1330000	480	630	413
23264CAME4	875000	1550000	450	600	522
23268CAME4	990000	1760000	400	530	643
23272CAME4	1080000	1920000	380	500	725
23276CAME4	1160000	2070000	360	480	812
23280CAME4	1300000	2340000	340	450	981
23284CAME4	1450000	2630000	320	430	1168
23288CAME4	1550000	2870000	300	400	1296
23292CAME4	1650000	3100000	280	380	1512
23296CAME4	1770000	3250000	260	360	1742
232/500CAME4	2020000	3750000	260	320	2132
232/530CAME4	2270000	4250000	240	300	2565
232/560CAME4	2460000	4600000	220	280	2911
232/600CAME4	2870000	5600000	200	260	3498
232/630CAME4	3000000	5750000	180	240	4065
232/670CAME4	3350000	6450000	170	220	4857
232/710CAME4	3500000	6850000	160	200	5440
232/750CAME4	3950000	7950000	140	190	6564
232/800CAME4	4550000	9200000	130	170	7156
232/850CAME4	5000000	10200000	120	160	8558
232/950CAME4	5550000	11300000	100	130	10568

C_r = Dynamic Radial Load Rating
 C_{or} = Static Radial Load Rating

Introduction

Ball Bearings

Cylindrical Roller Bearings

Spherical Roller Bearings

Tapered Roller Bearings

Thrust Bearings

Split Pillow Blocks

Super Precision Bearings

Linear Motion

Rolling Mill Bearings

Engineering Section



Spherical Roller Bearings

Series 23900

Bearing Number	Nominal Bearing Dimensions						Preferred Shoulder Diameters				
	<i>d</i>		<i>D</i>		<i>B</i>		<i>r</i> * (in)	<i>da</i> (in)		<i>Da</i> (in)	
	mm	inch	mm	inch	mm	inch	max	min	max	min	max
23926CAME4	130	5.1181	180	7.0866	37	1.4567	0.059	5.47	5.58	6.51	6.73
23932CAME4	160	6.2992	220	8.6614	45	1.7717	0.078	6.69	6.86	7.98	8.27
23934BCAME4	170	6.6929	230	9.0551	45	1.7717	0.078	7.09	7.26	8.38	8.66
23936CAME4	180	7.0866	250	9.8425	52	2.0472	0.078	7.48	7.75	9.05	9.45
23938CAME4	190	7.4803	260	10.2362	52	2.0472	0.078	7.87	8.14	9.45	9.84
23940CAME4	200	7.8740	280	11.0236	60	2.3622	0.078	8.35	8.66	10.15	10.55
23944CAME4	220	8.6614	300	11.8110	60	2.3622	0.078	9.13	9.42	10.91	11.34
23948CAME4	240	9.4488	320	12.5984	60	2.3622	0.078	9.92	10.22	11.71	12.13
23952CAME4	260	10.2362	360	14.1732	75	2.9528	0.078	10.71	11.23	13.09	13.70
23956CAME4	280	11.0236	380	14.9606	75	2.9528	0.078	11.50	12.03	13.80	14.49
23960CAME4	300	11.8110	420	16.5354	90	3.5433	0.098	12.36	13.00	15.17	15.98
23964CAME4	320	12.5984	440	17.3228	90	3.5433	0.098	13.15	13.83	15.98	16.77
23968CAME4	340	13.3858	460	18.1102	90	3.5433	0.098	13.94	14.55	16.78	17.56
23972CAME4	360	14.1732	480	18.8976	90	3.5433	0.098	14.72	15.39	17.58	18.35
23976CAME4	380	14.9606	520	20.4724	106	4.1732	0.118	15.67	16.39	18.95	19.76
23980CAME4	400	15.7480	540	21.2598	106	4.1732	0.118	16.46	17.15	19.71	20.55
23984CAME4	420	16.5354	560	22.0472	106	4.1732	0.118	17.24	17.95	20.52	21.34
23988CAME4	440	17.3228	600	23.6220	118	4.6457	0.118	18.03	18.90	21.83	22.91
23992CAME4	460	18.1102	620	24.4094	118	4.6457	0.118	18.82	19.70	22.63	23.70
23996CAME4	480	18.8976	650	25.5906	128	5.0394	0.157	19.76	20.56	23.68	24.72
239/500CAME4	500	19.6850	670	26.3780	128	5.0394	0.157	20.55	21.37	24.49	25.51
239/530CAME4	530	20.8661	710	27.9528	136	5.3543	0.157	21.73	22.65	25.95	27.09
239/560CAME4	560	22.0472	750	29.5276	140	5.5118	0.157	22.91	23.95	27.44	28.66
239/600CAME4	600	23.6220	800	31.4961	150	5.9055	0.157	24.49	25.60	29.30	30.63
239/630CAME4	630	24.8031	850	33.4646	165	6.4961	0.196	25.91	26.93	30.95	32.36
239/670CAME4	670	26.3780	900	35.4331	170	6.6929	0.196	27.48	28.66	32.92	34.33
239/710CAME4	710	27.9528	950	37.4016	180	7.0866	0.196	29.06	30.45	34.77	36.30
239/750CAME4	750	29.5276	1000	39.3701	185	7.2835	0.196	30.63	32.03	36.65	38.27
239/800CAME4	800	31.4961	1060	41.7323	195	7.6772	0.196	32.60	34.05	38.86	40.63
239/850CAME4	850	33.4646	1120	44.0945	200	7.8740	0.196	34.57	36.14	41.15	42.99
239/900CAME4	900	35.4331	1180	46.4567	206	8.1102	0.196	36.54	38.23	43.43	45.35
239/950CAME4	950	37.4016	1250	49.2126	224	8.8189	0.236	38.82	40.63	45.99	47.80
239/1000CAME4	1000	39.3701	1320	51.9685	236	9.2913	0.236	40.79	42.82	48.39	50.55
239/1060CAME4	1060	41.7323	1400	55.1181	250	9.8425	0.236	43.15	45.12	51.26	53.70
239/1120CAME4	1120	44.0945	1460	57.4803	250	9.8425	0.236	45.51	47.76	53.73	56.06
239/1180CAME4	1180	46.4567	1540	60.6299	272	10.7087	0.236	47.87	50.11	56.46	59.21
239/1250CAME4	1250	49.2126	1630	64.1732	280	11.0236	0.236	50.63	53.21	60.08	62.76
239/1400CAME4	1400	55.1181	1820	71.6535	315	12.4016	0.314	56.85	59.58	67.04	69.92

*Maximum fillet which corner radius of bearing will clear.

Application Data

Radial Internal Clearance — Table 10.39 on page 332
 Bearing Tolerances — Table 10.12 thru Table 10.16 on pages 315-17
 Shaft & Housing Fits — Table 10.31 and Table 10.33 on pages 328-29

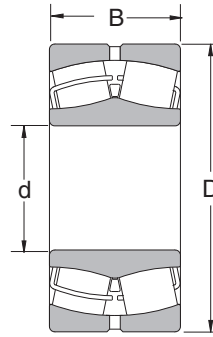
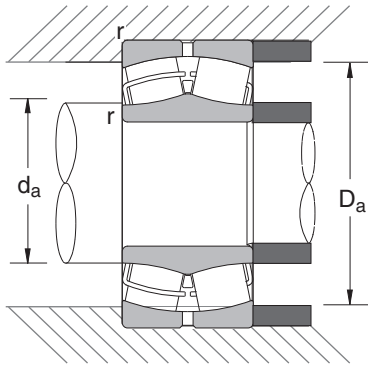

Common Options	
CAM	: One piece bronze cage
C,CD	: Two piece steel cage
EA	: High capacity steel cage
H	: Two piece polyamide cage
K	: 1:12 tapered bore
G3	: Inner ring carburized
E4	: Lube groove/holes, outer ring
P55	: High run accuracy both rings
S11	: Heat stabilized to 200°C
C2	: Tight internal clearance
CO†	: Normal internal clearance
C3	: Loose internal clearance

† Not shown in part number
See page 66 for additional options.

Bearing Number	Basic Load Ratings (lbs)		Limiting Speeds (RPM)		Bearing Weight (Approx.)
	C_r	C_{or}	Grease	Oil	lbs
23926CAME4	54000	95000	1800	2200	6.04
23932CAME4	81000	152000	1400	1800	10.78
23934BCAME4	78500	148000	1300	1700	11.69
23936CAME4	106000	200000	1200	1600	16.61
23938CAME4	104000	197000	1200	1500	17.46
23940CAME4	128000	239000	1100	1400	23.96
23944CAME4	141000	278000	1000	1300	26.57
23948CAME4	143000	292000	950	1200	28.90
23952CAME4	210000	420000	850	1000	50.13
23956CAME4	208000	440000	800	950	53.35
23960CAME4	276000	560000	710	900	83.46
23964CAME4	292000	620000	670	850	89.98
23968CAME4	300000	635000	630	800	92.66
23972CAME4	310000	690000	600	750	97.61
23976CAME4	420000	925000	530	670	142.8
23980CAME4	425000	955000	530	630	151.0
23984CAME4	420000	955000	500	600	156.4
23988CAME4	490000	1080000	450	560	211.8
23992CAME4	500000	1110000	430	530	219.2
23996CAME4	580000	1310000	400	500	263.3
239/500CAME4	550000	1250000	400	500	270.9
239/530CAME4	660000	1530000	360	450	326.3
239/560CAME4	700000	1630000	340	430	374.9
239/600CAME4	775000	1830000	320	400	451.2
239/630CAME4	895000	2100000	300	360	570.4
239/670CAME4	985000	2320000	260	340	661.0
239/710CAME4	1080000	2640000	240	300	775.0
239/750CAME4	1180000	2880000	220	280	876.4
239/800CAME4	1260000	3100000	220	260	1017
239/850CAME4	1370000	3400000	190	240	1151
239/900CAME4	1480000	3750000	180	220	1299
239/950CAME4	1710000	4500000	160	200	1609
239/1000CAME4	1840000	4900000	150	190	1937
239/1060CAME4	2090000	5500000	130	170	2263
239/1120CAME4	2130000	5850000	120	150	2430
239/1180CAME4	2380000	6550000	110	140	2879
239/1250CAME4	2600000	7050000	100	120	3355
239/1400CAME4	3200000	9100000	80	100	4709

C_r = Dynamic Radial Load Rating
 C_{or} = Static Radial Load Rating

Introduction
 Ball Bearings
 Cylindrical Roller Bearings
 Spherical Roller Bearings
 Tapered Roller Bearings
 Thrust Bearings
 Split Pillow Blocks
 Super Precision Bearings
 Linear Motion
 Rolling Mill Bearings
 Engineering Section



Spherical Roller Bearings

Series 24000

Bearing Number	Nominal Bearing Dimensions						Preferred Shoulder Diameters				
	<i>d</i>		<i>D</i>		<i>B</i>		<i>r</i> * (in)	<i>da</i> (in)		<i>Da</i> (in)	
	mm	inch	mm	inch	mm	inch	max	min	max	min	max
24020CE4	100	3.9370	150	5.9055	50	1.9685	0.059	4.29	4.33	5.20	5.55
24022CE4	110	4.3307	170	6.6929	60	2.3622	0.078	4.72	4.78	5.82	6.30
24024CE4	120	4.7244	180	7.0866	60	2.3622	0.078	5.12	5.17	6.21	6.69
24024CAME4	120	4.7244	180	7.0866	60	2.3622	0.078	5.12	5.18	6.21	6.69
24026CE4	130	5.1181	200	7.8740	69	2.7165	0.078	5.51	5.66	6.87	7.48
24026CAME4	130	5.1181	200	7.8740	69	2.7165	0.078	5.51	5.66	6.87	7.48
24028CE4	140	5.5118	210	8.2677	69	2.7165	0.078	5.91	6.07	7.29	7.87
24028CAME4	140	5.5118	210	8.2677	69	2.7165	0.078	5.91	6.05	7.26	7.87
24030CE4	150	5.9055	225	8.8583	75	2.9528	0.078	6.38	6.52	7.80	8.39
24030CAME4	150	5.9055	225	8.8583	75	2.9528	0.078	6.38	6.53	7.80	8.39
24032CE4	160	6.2992	240	9.4488	80	3.1496	0.078	6.77	6.97	8.33	8.98
24032CAME4	160	6.2992	240	9.4488	80	3.1496	0.078	6.77	6.98	8.33	8.98
24034CE4	170	6.6929	260	10.2362	90	3.5433	0.078	7.17	7.43	8.95	9.76
24034CAME4	170	6.6929	260	10.2362	90	3.5433	0.078	7.17	7.44	8.95	9.76
24036CE4	180	7.0866	280	11.0236	100	3.9370	0.078	7.56	7.88	9.63	10.55
24036CAME4	180	7.0866	280	11.0236	100	3.9370	0.078	7.56	7.90	9.63	10.55
24038CE4	190	7.4803	290	11.4173	100	3.9370	0.078	7.95	8.29	9.95	10.94
24038CAME4	190	7.4803	290	11.4173	100	3.9370	0.078	7.95	8.28	9.95	10.94
24040CE4	200	7.8740	310	12.2047	109	4.2913	0.078	8.35	8.78	10.66	11.73
24040CAME4	200	7.8740	310	12.2047	109	4.2913	0.078	8.35	8.79	10.66	11.73
24044CE4	220	8.6614	340	13.3858	118	4.6457	0.098	9.21	9.63	11.65	12.83
24044CAME4	220	8.6614	340	13.3858	118	4.6457	0.098	9.21	9.64	11.65	12.83
24048CE4	240	9.4488	360	14.1732	118	4.6457	0.098	10.00	10.45	12.49	13.62
24048CAME4	240	9.4488	360	14.1732	118	4.6457	0.098	10.00	10.45	12.49	13.62
24052CAME4	260	10.2362	400	15.7480	140	5.5118	0.118	10.94	11.32	13.70	15.04
24056CAME4	280	11.0236	420	16.5354	140	5.5118	0.118	11.73	12.17	14.50	15.83
24060CAME4	300	11.8110	460	18.1102	160	6.2992	0.118	12.52	13.08	15.75	17.40
24064CAME4	320	12.5984	480	18.8976	160	6.2992	0.118	13.31	13.90	16.60	18.19
24068CAME4	340	13.3858	520	20.4724	180	7.0866	0.157	14.25	14.90	17.87	19.61
24072CAME4	360	14.1732	540	21.2598	180	7.0866	0.157	15.04	15.67	18.73	20.39
24076CAME4	380	14.9606	560	22.0472	180	7.0866	0.157	15.83	16.46	19.51	21.18
24080CAME4	400	15.7480	600	23.6220	200	7.8740	0.157	16.61	17.33	20.72	22.76
24084CAME4	420	16.5354	620	24.4094	200	7.8740	0.157	17.40	18.18	21.58	23.54
24088CAME4	440	17.3228	650	25.5906	212	8.3465	0.196	18.43	19.07	22.67	24.49
24092CAME4	460	18.1102	680	26.7717	218	8.5827	0.196	19.21	20.01	23.75	25.67
24096CAME4	480	18.8976	700	27.5591	218	8.5827	0.196	20.00	20.71	24.59	26.46
240/500CAME4	500	19.6850	720	28.3465	218	8.5827	0.196	20.79	21.42	25.30	27.24
240/530CAME4	530	20.8661	780	30.7087	250	9.8425	0.196	21.97	22.83	27.17	29.61
240/560CAME4	560	22.0472	820	32.2835	258	10.1575	0.196	23.15	24.18	28.71	31.18
240/600CAME4	600	23.6220	870	34.2520	272	10.7087	0.196	24.72	25.72	30.38	33.15
240/630CAME4	630	24.8031	920	36.2205	290	11.4173	0.236	26.22	27.19	32.08	34.80
240/670CAME4	670	26.3780	980	38.5827	308	12.1260	0.236	27.80	28.80	34.15	37.17
240/710CAME4	710	27.9528	1030	40.5512	315	12.4016	0.236	29.37	30.50	36.06	39.13
240/800CAME4	800	31.4961	1150	45.2756	345	13.5827	0.236	32.91	34.45	40.50	43.86
240/850CAME4	850	33.4646	1220	48.0315	365	14.3701	0.236	34.88	36.64	43.03	46.61
240/950CAME4	950	37.4016	1360	53.5433	412	16.2205	0.236	38.82	40.85	47.97	52.13
240/1000CAME4	1000	39.3701	1420	55.9055	412	16.2205	0.236	40.79	42.84	50.19	54.49
240/1120CAME4	1120	44.0945	1580	62.2047	462	18.1890	0.314	45.83	48.14	55.92	60.47
240/1250CAME4	1250	49.2126	1750	68.8976	500	19.6850	0.314	50.94	54.35	62.15	67.17
240/1320CAME4	1320	51.9685	1850	72.8346	530	20.8661	0.393	54.09	57.16	65.17	70.71
240/1400CAME4	1400	55.1181	1950	76.7717	545	21.4567	0.393	57.24	59.77	69.57	74.65

*Maximum fillet which corner radius of bearing will clear.

Application Data

Radial Internal Clearance — Table 10.39 on page 332
 Bearing Tolerances — Table 10.12 thru Table 10.16 on pages 315-17
 Shaft & Housing Fits — Table 10.31 and Table 10.33 on pages 328-29

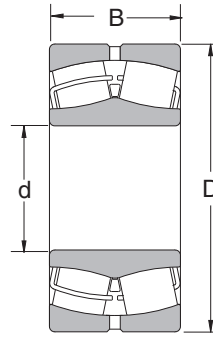
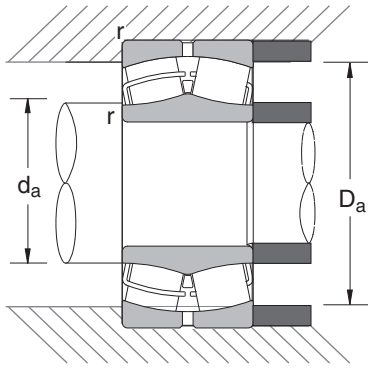

Common Options	
CAM	: One piece bronze cage
C,CD	: Two piece steel cage
EA	: High capacity steel cage
H	: Two piece polyamide cage
K	: 1:12 tapered bore
G3	: Inner ring carburized
E4	: Lube groove/holes, outer ring
P55	: High run accuracy both rings
S11	: Heat stabilized to 200°C
C2	: Tight internal clearance
C0†	: Normal internal clearance
C3	: Loose internal clearance

† Not shown in part number
See page 66 for additional options.

Bearing Number	Basic Load Ratings (lbs)		Limiting Speeds (RPM)		Bearing Weight (Approx.)
	C_r	C_{or}	Grease	Oil	lbs
24020CE4	62000	106000	1800	2400	6.72
24022CE4	85000	145000	1600	2200	10.80
24024CE4	89500	158000	1500	2000	11.62
24024CAME4	86500	152000	1500	2000	10.92
24026CE4	111000	194000	1400	1800	17.05
24026CAME4	111000	194000	1400	1800	16.46
24028CE4	117000	213000	1300	1700	18.21
24028CAME4	114000	204000	1300	1700	17.27
24030CE4	133000	245000	1200	1500	22.83
24030CAME4	133000	245000	1200	1500	22.29
24032CE4	152000	283000	1100	1400	27.62
24032CAME4	152000	283000	1100	1400	26.95
24034CE4	185000	340000	1000	1300	37.75
24034CAME4	185000	340000	1000	1300	36.85
24036CE4	217000	395000	950	1200	49.51
24036CAME4	217000	395000	950	1200	48.46
24038CE4	219000	415000	900	1200	52.32
24038CAME4	219000	415000	900	1200	50.39
24040CE4	256000	475000	850	1100	66.32
24040CAME4	256000	475000	850	1100	63.88
24044CE4	305000	585000	750	1000	86.66
24044CAME4	296000	560000	750	1000	83.84
24048CE4	310000	615000	710	950	92.41
24048CAME4	310000	615000	710	950	89.81
24052CAME4	405000	790000	630	850	136.5
24056CAME4	420000	855000	600	800	144.8
24060CAME4	520000	1040000	530	710	204.3
24064CAME4	550000	1130000	500	670	217.8
24068CAME4	655000	1360000	480	600	294.8
24072CAME4	660000	1370000	450	600	303.6
24076CAME4	690000	1480000	430	560	323.2
24080CAME4	810000	1710000	400	500	422.6
24084CAME4	840000	1820000	380	480	434.1
24088CAME4	940000	2050000	360	450	503.3
24092CAME4	1010000	2240000	340	430	579.7
24096CAME4	1040000	2290000	320	430	590.0
240/500CAME4	995000	2220000	300	400	607.6
240/530CAME4	1210000	2660000	280	360	857.2
240/560CAME4	1340000	3000000	260	340	969.1
240/600CAME4	1480000	3400000	240	320	1164
240/630CAME4	1700000	4000000	220	300	1400
240/670CAME4	1900000	4400000	200	260	1701
240/710CAME4	1990000	4650000	190	240	1894
240/800CAME4	2440000	5900000	160	200	2480
240/850CAME4	2610000	6350000	150	190	2965
240/950CAME4	3250000	8150000	120	160	4146
240/1000CAME4	3450000	8700000	110	150	4421
240/1120CAME4	4200000	11100000	95	120	6143
240/1250CAME4	4700000	13400000	75	100	8136
240/1320CAME4	5100000	14300000	67	85	9673
240/1400CAME4	5500000	14600000	60	75	10772

C_r = Dynamic Radial Load Rating
 C_{or} = Static Radial Load Rating

Introduction
 Ball Bearings
 Cylindrical Roller Bearings
 Spherical Roller Bearings
 Tapered Roller Bearings
 Thrust Bearings
 Split Pillow Blocks
 Super Precision Bearings
 Linear Motion
 Rolling Mill Bearings
 Engineering Section



Spherical Roller Bearings

Series 24100

Bearing Number	Nominal Bearing Dimensions						Preferred Shoulder Diameters				
	<i>d</i>		<i>D</i>		<i>B</i>		<i>r</i> * (in)	<i>da</i> (in)		<i>Da</i> (in)	
	mm	inch	mm	inch	mm	inch	max	min	max	min	max
24120CAME4	100	3.9370	165	6.4961	65	2.5591	0.078	4.33	4.50	5.62	6.10
24122CE4	110	4.3307	180	7.0866	69	2.7165	0.078	4.72	4.86	6.04	6.69
24122CAME4	110	4.3307	180	7.0866	69	2.7165	0.078	4.72	4.87	6.04	6.69
24124CE4	120	4.7244	200	7.8740	80	3.1496	0.078	5.12	5.36	6.72	7.48
24124CAME4	120	4.7244	200	7.8740	80	3.1496	0.078	5.12	5.36	6.72	7.48
24126CE4	130	5.1181	210	8.2677	80	3.1496	0.078	5.51	5.77	7.09	7.87
24126CAME4	130	5.1181	210	8.2677	80	3.1496	0.078	5.51	5.75	7.09	7.87
24128CE4	140	5.5118	225	8.8583	85	3.3465	0.078	5.98	6.15	7.57	8.39
24128CAME4	140	5.5118	225	8.8583	85	3.3465	0.078	5.98	6.12	7.53	8.39
24130CE4	150	5.9055	250	9.8425	100	3.9370	0.078	6.38	6.65	8.33	9.37
24130CAME4	150	5.9055	250	9.8425	100	3.9370	0.078	6.38	6.68	8.33	9.37
24132CE4	160	6.2992	270	10.6299	109	4.2913	0.078	6.77	7.07	8.99	10.16
24132CAME4	160	6.2992	270	10.6299	109	4.2913	0.078	6.77	7.14	8.99	10.16
24134CE4	170	6.6929	280	11.0236	109	4.2913	0.078	7.17	7.49	9.39	10.55
24134CAME4	170	6.6929	280	11.0236	109	4.2913	0.078	7.17	7.54	9.39	10.55
24136CE4	180	7.0866	300	11.8110	118	4.6457	0.098	7.64	7.98	10.04	11.26
24136CAME4	180	7.0866	300	11.8110	118	4.6457	0.098	7.64	7.99	10.04	11.26
24138CE4	190	7.4803	320	12.5984	128	5.0394	0.098	8.03	8.31	10.58	12.05
24138CAME4	190	7.4803	320	12.5984	128	5.0394	0.098	8.03	8.41	10.57	12.05
24140CE4	200	7.8740	340	13.3858	140	5.5118	0.098	8.43	8.90	11.39	12.83
24140CAME4	200	7.8740	340	13.3858	140	5.5118	0.098	8.43	8.92	11.39	12.83
24144CE4	220	8.6614	370	14.5669	150	5.9055	0.118	9.37	9.78	12.30	13.86
24144CAME4	220	8.6614	370	14.5669	150	5.9055	0.118	9.37	9.82	12.30	13.86
24148CE4	240	9.4488	400	15.7480	160	6.2992	0.118	10.16	10.55	13.42	15.04
24148CAME4	240	9.4488	400	15.7480	160	6.2992	0.118	10.16	10.59	13.42	15.04
24152CE4	260	10.2362	440	17.3228	180	7.0866	0.118	10.94	11.60	14.60	16.61
24152CAME4	260	10.2362	440	17.3228	180	7.0866	0.118	10.94	11.65	14.60	16.61
24156CXE4	280	11.0236	460	18.1102	180	7.0866	0.157	11.89	12.39	15.42	17.24
24156CAME4	280	11.0236	460	18.1102	180	7.0866	0.157	11.89	12.43	15.42	17.24
24160CXE4	300	11.8110	500	19.6850	200	7.8740	0.157	12.68	13.27	16.62	18.82
24160CAME4	300	11.8110	500	19.6850	200	7.8740	0.157	12.68	13.33	16.62	18.82
24164CE4	320	12.5984	540	21.2598	218	8.5827	0.157	13.46	14.25	17.95	20.39
24164CAME4	320	12.5984	540	21.2598	218	8.5827	0.157	13.46	14.32	17.95	20.39
24168CXE4	340	13.3858	580	22.8346	243	9.5669	0.157	14.25	15.12	19.23	21.97
24168CAME4	340	13.3858	580	22.8346	243	9.5669	0.157	14.25	15.19	19.23	21.97
24172CAME4	360	14.1732	600	23.6220	243	9.5669	0.157	15.04	15.95	19.95	22.76
24176CXE4	380	14.9606	620	24.4094	243	9.5669	0.157	15.83	16.69	20.72	23.54
24176CAME4	380	14.9606	620	24.4094	243	9.5669	0.157	15.83	16.77	20.80	23.54
24180CAME4	400	15.7480	650	25.5906	250	9.8425	0.196	16.85	17.65	21.69	24.49
24184CAME4	420	16.5354	700	27.5591	280	11.0236	0.196	17.64	18.84	23.51	26.46
24188CAME4	440	17.3228	720	28.3465	280	11.0236	0.196	18.43	19.64	24.27	27.24
24192CAME4	460	18.1102	760	29.9213	300	11.8110	0.236	19.53	20.40	25.43	28.50
24196CAME4	480	18.8976	790	31.1024	308	12.1260	0.236	20.31	21.25	26.38	29.69
241/500CAME4	500	19.6850	830	32.6772	325	12.7953	0.236	21.10	22.02	27.68	31.26
241/560CAME4	560	22.0472	920	36.2205	355	13.9764	0.236	23.46	24.79	30.76	34.80
241/600CAME4	600	23.6220	980	38.5827	375	14.7638	0.236	25.04	26.53	32.88	37.17
241/630CAME4	630	24.8031	1030	40.5512	400	15.7480	0.236	26.22	27.80	34.47	39.13
241/670CAME4	670	26.3780	1090	42.9134	412	16.2205	0.236	27.80	29.72	36.74	41.50

*Maximum fillet which corner radius of bearing will clear.

Application Data

Radial Internal Clearance — Table 10.39 on page 332
 Bearing Tolerances — Table 10.12 thru Table 10.16 on pages 315-17
 Shaft & Housing Fits — Table 10.31 and Table 10.33 on pages 328-29

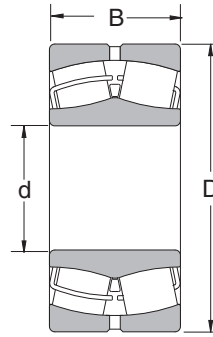
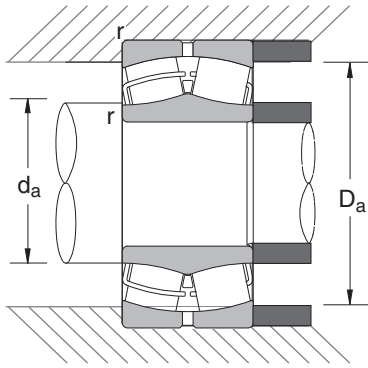

Common Options	
CAM	: One piece bronze cage
C,CD	: Two piece steel cage
EA	: High capacity steel cage
H	: Two piece polyamide cage
K	: 1:12 tapered bore
G3	: Inner ring carburized
E4	: Lube groove/holes, outer ring
P55	: High run accuracy both rings
S11	: Heat stabilized to 200°C
C2	: Tight internal clearance
C0†	: Normal internal clearance
C3	: Loose internal clearance

† Not shown in part number
See page 66 for additional options.

Bearing Number	Basic Load Ratings (lbs)		Limiting Speeds (RPM)		Bearing Weight (Approx.)
	C_r	C_{or}	Grease	Oil	lbs
24120CAME4	77500	121000	1700	2200	11.83
24122CE4	103000	168000	1600	2000	14.87
24122CAME4	103000	168000	1600	2000	14.41
24124CE4	129000	213000	1400	1800	21.85
24124CAME4	125000	203000	1400	1800	20.83
24126CE4	133000	228000	1300	1700	23.34
24126CAME4	132000	227000	1300	1700	22.13
24128CE4	151000	261000	1200	1600	28.25
24128CAME4	150000	260000	1200	1600	27.02
24130CE4	200000	345000	1100	1400	43.23
24130CAME4	193000	325000	1100	1400	41.05
24132CE4	234000	395000	1000	1300	55.36
24132CAME4	223000	375000	1000	1300	53.45
24134CE4	242000	420000	1000	1300	58.04
24134CAME4	230000	400000	1000	1300	55.70
24136CE4	268000	460000	900	1200	72.29
24136CAME4	267000	460000	900	1200	70.82
24138CE4	310000	525000	850	1100	90.33
24138CAME4	294000	505000	850	1100	88.07
24140CE4	350000	600000	800	1000	111.9
24140CAME4	350000	600000	800	1000	109.2
24144CE4	405000	720000	710	950	146.7
24144CAME4	405000	720000	710	950	137.7
24148CE4	480000	850000	670	850	173.7
24148CAME4	480000	850000	670	850	172.2
24152CE4	575000	1050000	600	800	242.0
24152CAME4	575000	1050000	600	800	237.4
24156CXE4	550000	1010000	560	750	251.7
24156CAME4	595000	1120000	560	750	250.5
24160CXE4	670000	1240000	500	670	339.8
24160CAME4	695000	1310000	500	670	332.7
24164CE4	795000	1490000	480	600	440.0
24164CAME4	795000	1490000	480	600	427.2
24168CXE4	915000	1690000	430	560	561.5
24168CAME4	955000	1780000	430	560	560.2
24172CAME4	945000	1800000	400	530	576.0
24176CXE4	945000	1820000	400	500	612.9
24176CAME4	975000	1900000	400	500	600.5
24180CAME4	1110000	2260000	380	480	691.5
24184CAME4	1350000	2690000	340	450	919.5
24188CAME4	1340000	2710000	320	430	947.5
24192CAME4	1410000	2800000	300	400	1121
24196CAME4	1610000	3300000	300	380	1248
241/500CAME4	1800000	3600000	280	360	1465
241/560CAME4	2120000	4400000	240	320	1948
241/600CAME4	2340000	4900000	220	280	2310
241/630CAME4	2460000	5150000	200	260	2739
241/670CAME4	2790000	5950000	190	240	3175

C_r = Dynamic Radial Load Rating
 C_{or} = Static Radial Load Rating

Introduction
Ball Bearings
Cylindrical Roller Bearings
Spherical Roller Bearings
Tapered Roller Bearings
Thrust Bearings
Split Pillow Blocks
Super Precision Bearings
Linear Motion
Rolling Mill Bearings
Engineering Section

Shaker Screen Bearings

22300/23300 Series

223 Series

Bearing Number	Bearing Dimensions						CAM Design			H Design		
	Bore		O.D.		Width		Capacity	Limiting Speeds (RPM)		Capacity	Limiting Speeds (RPM)	
	mm	inch	mm	inch	mm	inch	Cr (lbf)	Grease	Oil	Cr (lbf)	Grease	Oil
22308	40	1.5748	90	3.5433	33	1.2992	27400	4300	5300	30500	4500	6000
22309	45	1.7717	100	3.937	36	1.4173	33000	3800	4800	36000	4000	5300
22310	50	1.9685	110	4.3307	40	1.5748	41500	3600	4300	44000	3800	4800
22311	55	2.1654	120	4.7244	43	1.6929	47000	3200	4000	51000	3400	4300
22312	60	2.3622	130	5.1181	46	1.811	55500	3000	3600	59500	3200	4000
22313	65	2.5591	140	5.5118	48	1.8898	59500	2800	3400	68500	3000	3800
22314	70	2.7559	150	5.9055	51	2.0079	69000	2600	3200	75500	2800	3400
22315	75	2.9528	160	6.2992	55	2.1654	76500	2400	3000	86500	2600	3200
22316	80	3.1496	170	6.6929	58	2.2835	87500	2200	2800	97000	2400	3000
22317	85	3.3465	180	7.0866	60	2.3622	93500	2000	2600	105000	2200	2800
22318	90	3.5433	190	7.4803	64	2.5197	109000	2000	2400	119000	2200	2600
22319	95	3.7402	200	7.874	67	2.6378	118000	1900	2400	129000	2000	2600
22320	100	3.937	215	8.4646	73	2.874	135000	1700	2200	150000	1900	2400
22322	110	4.3307	240	9.4488	80	3.1496	166000	1600	1900	184000	1700	2200
22324	120	4.7244	260	10.2362	86	3.3858	190000	1400	1800	-	-	-
22326	130	5.1181	280	11.0236	93	3.6614	223000	1300	1600	-	-	-
22328	140	5.5118	300	11.811	102	4.0157	260000	1200	1500	-	-	-
22330	150	5.9055	320	12.5984	108	4.252	275000	1100	1400	-	-	-
22332	160	6.2992	340	13.3858	114	4.4882	305000	1100	1300	-	-	-
22334	170	6.6929	360	14.1732	120	4.7244	355000	1000	1200	-	-	-
22336	180	7.0866	380	14.9606	126	4.9606	390000	950	1200	-	-	-
22338	190	7.4803	400	15.748	132	5.1969	425000	900	1100	-	-	-
22340	200	7.874	420	16.5354	138	5.4331	450000	850	1000	-	-	-

233 Series

23326	130	5.1181	280	11.0236	112	4.4094	233000	1100	1400	-	-	-
23330	150	5.9055	320	12.5984	128	5.0394	315000	950	1200	-	-	-
23332	160	6.2992	340	13.3858	136	5.3543	350000	850	1100	-	-	-

Application Data

Radial Internal Clearance — Table 10.39 on page 332
 Bearing Tolerances — Table 10.12 thru Table 10.16 on pages 315-17
 Shaft & Housing Fits — Table 10.31 and Table 10.33 on pages 328-29

Shaker Screen Bearings

22300/23300 Series
Fitting Recommendations

223 Series

Bearing Number	Shaft Diameter (in)			Housing Bore Diameter (in)			Press Force (lbf)				Housing Temp for Shrink Fit
							With E4		Without E4		
	max	min	fit	min	max	fit	min	max	min	max	
22308	1.5742	1.5738	.0003L-.0010L	3.5413	3.5422	.0007T-.0018T	990	2540	1260	3250	200°F
22309	1.7711	1.7707	.0003L-.0010L	3.9350	3.9359	.0007T-.0018T	1110	2850	1380	3550	190°F
22310	1.9679	1.9675	.0003L-.0010L	4.3287	4.3296	.0007T-.0018T	1230	3170	1500	3870	180°F
22311	2.1648	2.1644	.0006L-.0014L	4.7224	4.7233	.0007T-.0018T	1090	2790	1480	3820	170°F
22312	2.3612	2.3608	.0006L-.0014L	5.1157	5.1167	.0009T-.0022T	1760	4300	2360	5770	180°F
22313	2.5581	2.5577	.0006L-.0014L	5.5094	5.5104	.0009T-.0022T	1731	4230	2290	5590	170°F
22314	2.7549	2.7545	.0006L-.0014L	5.9031	5.9041	.0009T-.0022T	1900	4640	2610	6370	170°F
22315	2.9518	2.9514	.0006L-.0014L	6.2968	6.2978	.0006T-.0022T	1410	5180	1880	6910	160°F
22316	3.1486	3.1482	.0006L-.0014L	6.6905	6.6915	.0006T-.0022T	1520	5570	1990	7280	160°F
22317	3.3452	3.3448	.0008L-.0017L	7.0842	7.0852	.0006T-.0022T	1550	5680	2010	7370	150°F
22318	3.5420	3.5416	.0008L-.0017L	7.4775	7.4786	.0007T-.0024T	2080	7130	2650	9070	160°F
22319	3.7389	3.7385	.0008L-.0017L	7.8712	7.8723	.0007T-.0024T	2010	6890	2630	9030	160°F
22320	3.9357	3.9353	.0008L-.0017L	8.4618	8.4629	.0007T-.0024T	2100	7200	2680	9180	150°F
22322	4.3294	4.3290	.0008L-.0017L	9.4460	9.4471	.0007T-.0024T	2440	8360	3030	10400	150°F
22324	4.7231	4.7227	.0008L-.0017L	10.2331	10.2344	.0010T-.0027T	3880	10500	5050	13600	150°F
22326	5.1165	5.1160	.0010L-.0021L	11.0205	11.0218	.0010T-.0027T	4170	11300	5330	14400	140°F
22328	5.5102	5.5097	.0010L-.0021L	11.8079	11.8092	.0010T-.0027T	4310	11600	5670	15300	150°F
22330	5.9039	5.9034	.0010L-.0021L	12.5950	12.5964	.0009T-.0029T	3910	12600	5060	16300	140°F
22332	6.2976	6.2971	.0010L-.0021L	13.3824	13.3838	.0009T-.0029T	4650	15000	5900	19000	140°F
22334	6.6913	6.6908	.0010L-.0021L	14.1698	14.1712	.0009T-.0029T	5100	16400	6400	20600	140°F
22336	7.0850	7.0845	.0010L-.0021L	14.9572	14.9586	.0009T-.0029T	4920	15900	6340	20400	130°F
22338	7.4784	7.4778	.0012L-.0025L	15.7446	15.7460	.0009T-.0029T	5130	16500	6540	21100	130°F
22340	7.8721	7.8715	.0012L-.0025L	16.5317	16.5333	.0010T-.0032T	6350	20300	8000	25600	140°F

233 Series

23326	5.1165	5.1160	.0010L-.0021L	11.0205	11.0218	.0010T-.0027T	5260	14200	-	-	140°F
23330	5.9039	5.9034	.0010L-.0021L	12.5950	12.5964	.0009T-.0029T	4990	16100	-	-	140°F
23332	6.2976	6.2971	.0010L-.0021L	13.3824	13.3838	.0009T-.0029T	6040	19500	-	-	140°F

Introduction

Ball Bearings

Cylindrical Roller Bearings

Spherical Roller Bearings

Tapered Roller Bearings

Thrust Bearings

Split Pillow Blocks

Super Precision Bearings

Linear Motion

Rolling Mill Bearings

Engineering Section

Shaker Screen Bearing

Radial Internal Clearance (inches)

Bearing Bore (mm)	Unmounted				Mounted			
	C3		C4		C3		C4	
	min	max	min	max	min	max	min	max
40	0.0020	0.0024	0.0026	0.0031	0.0006	0.0019	0.0012	0.0026
45-50	0.0024	0.0031	0.0033	0.0039	0.0010	0.0026	0.0019	0.0034
55	0.0029	0.0035	0.0039	0.0047	0.0015	0.0030	0.0025	0.0042
60-65	0.0029	0.0035	0.0039	0.0047	0.0012	0.0038	0.0022	0.0040
70	0.0035	0.0043	0.0047	0.0057	0.0018	0.0036	0.0030	0.0050
75-80	0.0035	0.0043	0.0047	0.0057	0.0018	0.0038	0.0030	0.0052
85	0.0043	0.0053	0.0059	0.0071	0.0026	0.0048	0.0042	0.0066
90-100	0.0043	0.0053	0.0059	0.0071	0.0025	0.0048	0.0041	0.0066
110	0.0053	0.0063	0.0070	0.0083	0.0036	0.0058	0.0052	0.0078
120	0.0053	0.0063	0.0070	0.0083	0.0032	0.0055	0.0049	0.0075
130-140	0.0063	0.0075	0.0081	0.0094	0.0042	0.0067	0.0060	0.0086
150-160	0.0075	0.0087	0.0094	0.0110	0.0053	0.0080	0.0072	0.0103
170-180	0.0079	0.0094	0.0104	0.0122	0.0057	0.0087	0.0082	0.0115
190	0.0087	0.0102	0.0113	0.0134	0.0065	0.0095	0.0091	0.0127
200	0.0087	0.0102	0.0113	0.0134	0.0063	0.0094	0.0089	0.0126

Introduction

Ball Bearings

Cylindrical Roller Bearings

Spherical Roller Bearings

Tapered Roller Bearings

Thrust Bearings

Split Pillow Blocks

Super Precision Bearings

Linear Motion

Rolling Mill Bearings

Engineering Section

Triple Ring Bearing

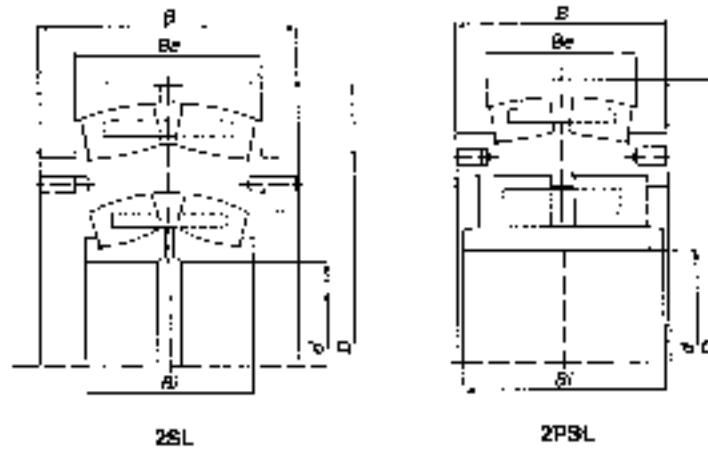

Bearing Number	Boundary Dimensions					Mass	
	d	D	Bi	Be	B	kg	lbs
2SL180-2 UPA	180	480	140	160	215.9	165	364
2SL200-2 UPA	200	520	160	180	241.3	230	507
2SL220-2 UPA	220	600	180	200	279.4	330	728
2SL240-2 UPA	240	620	200	200	279.4	410	904
2PSL240-1 UPA	240	600	205	160	225	285	628
2SL260-2 UPA	260	680	218	218	317.5	490	1080
2SL280-2 UPA	280	720	218	218	317.5	525	1157
2SL300-2 UPA	300	780	243	250	342.9	735	1620
2SL320-2 UPA	320	820	258	258	368.3	840	1851
2SL340-2 UPA	340	870	280	272	393.7	1050	2314

Introduction

Ball Bearings

Cylindrical Roller Bearings

Spherical Roller Bearings

Tapered Roller Bearings

Thrust Bearings

Split Pillow Blocks

Super Precision Bearings

Linear Motion

Rolling Mill Bearings

Engineering Section

Table of Contents Tapered Roller Bearings

INTRODUCTION

About NSK Tapered Roller Bearings100

NOMENCLATURE/INTERCHANGE

Metric Tapered Nomenclature101

Metric Tapered Interchange101

Inch Tapered Nomenclature102

Inch Tapered Interchange102

APPLICATION

Tapered Roller Applications103

BEARING TABLES

30200 Metric Series: Bore 15 to 32mm104

30300 Metric Series: Bore 35 to 50mm106

31300 Metric Series: Bore 55 to 70mm108

32000 Metric Series: Bore 75 to 85mm110

32200 Metric Series: Bore 90 to 100mm . . .112

32300 Metric Series: Bore 105 to 120mm . .114

32900 Metric Series: Bore 130 to 160mm . .116

33000 Metric Series: Bore 170 to 200mm . .118

33100 Metric Series: Bore 220 to 400mm . .120

33200 Metric Series: Bore 25 to 100mm . . .122

30200C Metric Series: Medium Angle124

30300C Metric Series: Medium Angle126

32200C Metric Series: Medium Angle128

32300C Metric Series: Medium Angle130

Inch Series132

Introduction

ABOUT NSK TAPERED ROLLER BEARINGS

- HR Metric Taper Roller Bearings
- Inch Taper Roller Bearings

Tapered roller bearings are designed to take combined heavy radial loads and heavy thrust loads in one direction while operating at moderate speeds. The bearings shown are single row with a cone and cup (inner and outer rings) and a pressed steel retainer. **Metric** tapers feature a simplified part number for a complete bearing. **Inch** tapers require a part number for the cup and one for the cone. The difference between the metric and inch tapers is only in the dimensions of measure for the bearings.

NSK's patented **HR** metric taper offers extra capacity within the same boundary dimensions. This means that an ordinary metric taper can easily be replaced with NSK's **HR** metric taper.

Nomenclature — Metric Tapered Roller Bearings

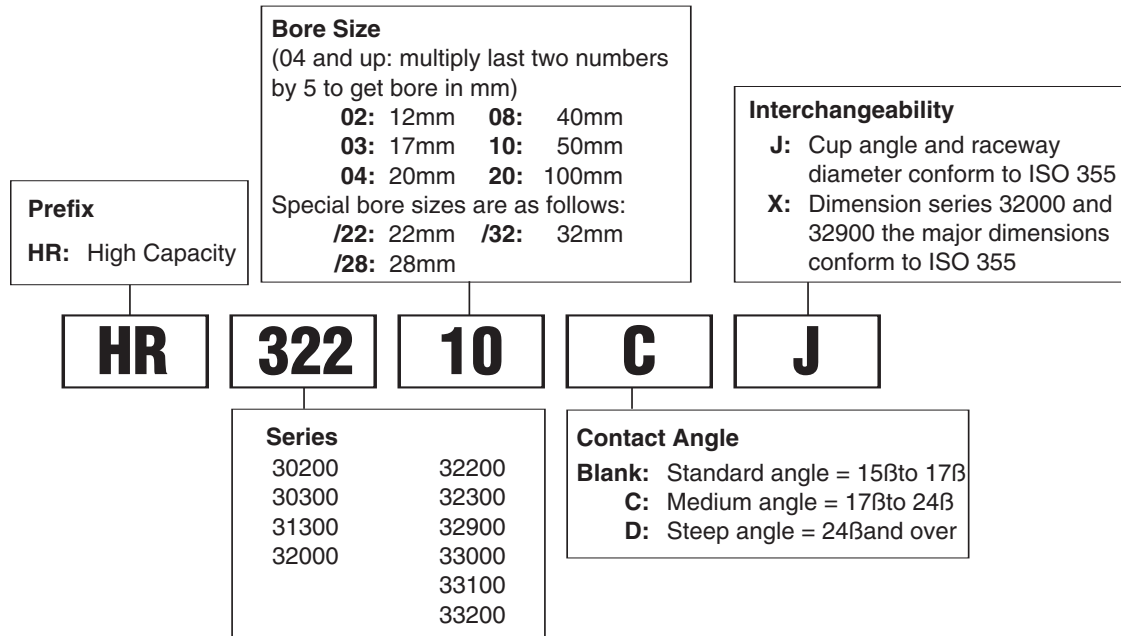

Please refer to the bearing tables for exact part number options.

Interchange — Metric Tapered Roller Bearings

DESCRIPTION		INTERCHANGE			
		NSK	SKF	Timken	FAG
Part Number	HIGH CAPACITY DESIGN	HR	--	--	--
	LIGHT	HR302xx	302xx	302xx	302xx
	MEDIUM	HR303xx	303xx	303xx	303xx
	MEDIUM, STEEP ANGLE	HR313xx	313xx	313xx	313xx
	EXTRA LIGHT, WIDE	HR329xx	329xx	329xx	329xx
	VERY LIGHT, WIDE	HR320xx	320xx	320xx	320xx
	LIGHT, WIDE	HR322xx	322xx	322xx	322xx
	MEDIUM, WIDE	HR323xx	323xx	323xx	323xx
	VERY LIGHT, EXTRA WIDE	HR330xx	330xx	330xx	330xx
	LIGHT, EXTRA WIDE	HR331xx	331xx	331xx	331xx
MEDIUM, EXTRA WIDE	HR332xx	332xx	332xx	332xx	
Suffix	MEDIUM CONTACT ANGLE	C	B	B	B
	STEEP CONTACT ANGLE	D	--	--	--
	MODIFIED INTERNAL DESIGN	X	X	X	X
	CONFORMS TO ISO 355	J	--	--	A

Nomenclature — Inch Tapered Roller Bearings

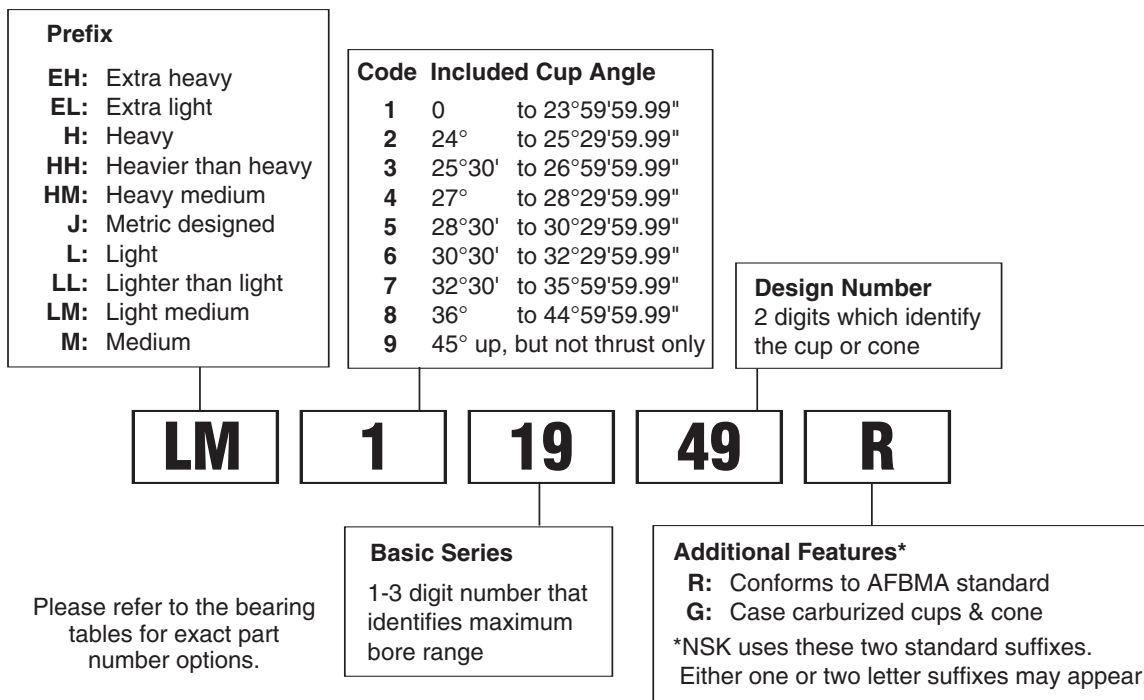

Interchange — Inch Tapered Roller Bearings

DESCRIPTION		INTERCHANGE			
		NSK	SKF	Timken	FAG
Prefix	EXTRA HEAVY	EH	EH	EH	KEH
	HEAVIER THAN HEAVY	HH	HH	HH	KHH
	HEAVY	H	H	H	KH
	HEAVY MEDIUM	HM	HM	HM	KHM
	MEDIUM	M	M	M	KM
	LIGHT MEDIUM	LM	LM	LM	KLM
	LIGHT	L	L	L	KL
	LIGHTER THAN LIGHT	LL	LL	LL	KLL
	EXTRA LIGHT	EL	EL	EL	KEL
Cup Angle	0° TO 23°59'59.99	1xxx	1xxx	1xxx	1xxx
	24° TO 25°29'59.99	2xxx	2xxx	2xxx	2xxx
	25°30' TO 26°59'59.99	3xxx	3xxx	3xxx	3xxx
	27° TO 28°29'59.99	4xxx	4xxx	4xxx	4xxx
	28°30' TO 30°29'59.99	5xxx	5xxx	5xxx	5xxx
	30°30' TO 32°29'59.99	6xxx	6xxx	6xxx	6xxx
	32°30' TO 35°59'59.99	7xxx	7xxx	7xxx	7xxx
	36° TO 44°59'59.99	8xxx	8xxx	8xxx	8xxx
	45° up, but not thrust only	9xxx	9xxx	9xxx	9xxx
CONFORMS TO AFBMA STANDARD	R				
CASE CARBURIZED CUP & CONE	G				

Tapered Roller Bearing Applications

Shown below are some common applications utilizing a tapered roller bearing design. The design allows for combinations of heavy radial and thrust loads with low to moderate speeds. This section covers only single row tapers although NSK manufactures a full line of two and four row tapers as well. For more details on multiple row tapered roller bearings, please see the Rolling Mill section of this catalog or contact an NSK representative.

Metric designs function the same as their inch series cousins, the difference lies in the units of measure. NSK metric tapers are standardly supplied with cup and cone together, while inch series bearings are available by the cup, cone, or cup and cone. The applications shown below are for either metric or inch bearings, with the equipment manufacturer choosing the preference of dimensional measurements. Metric tapers are usually found in equipment designed in Europe or Asia.

- Guide Boxes in Bar and Rod Mills
- Pumps and Compressors
- Cranes and Hoists
- Gears and Drives
- Stamping Presses
- Machine Tool Spindles
- Bow Thrusts on Ships
- Speed Reducers
- Transmissions
- Sheaves
- Conveyor and Transfer Equipment
- Coupling Equipment
- Construction Equipment
- Mining Equipment
- Oil Field Equipment
- Automotive Front and Rear Axles
- Plastic Forming Equipment
- Agriculture Equipment
- Motorcycle Wheels
- Pinion Shafts of Differential Gears
- Drum Shafts
- Crankshafts
- Crushers



Tapered Roller Bearings

30200 Metric Series

Bore Diameter 15 – 320 mm

0.5906 – 12.5984 inch

Bearing Number	Nominal Bearing Dimensions										Preferred Shoulder Diameters (in)			
	<i>d</i>		<i>D</i>		<i>T</i>		<i>B</i>		<i>C</i>		<i>r</i> *	<i>d</i> _a (min)	<i>d</i> _b (max)	<i>D</i> _a (max)
	mm	inch	mm	inch	mm	inch	mm	inch	mm	inch				
HR30202	15	0.5906	35	1.3780	11.75	0.4626	11	0.4331	10	0.3937	0.02	0.906	0.748	1.181
HR30203J	17	0.6693	40	1.5748	13.25	0.5217	12	0.4724	11	0.4331	0.04	1.024	0.906	1.339
HR30204J	20	0.7874	47	1.8504	15.25	0.6004	14	0.5512	12	0.4724	0.04	1.142	1.063	1.614
HR30205J	25	0.9843	52	2.0472	16.25	0.6398	15	0.5906	13	0.5118	0.04	1.339	1.220	1.811
HR30206J	30	1.1811	62	2.4409	17.25	0.6791	16	0.6299	14	0.5512	0.04	1.535	1.457	2.205
HR30207J	35	1.3780	72	2.8346	18.25	0.7185	17	0.6693	15	0.5906	0.06	1.811	1.693	2.480
HR30208J	40	1.5748	80	3.1496	19.75	0.7776	18	0.7087	16	0.6299	0.06	2.008	1.890	2.795
HR30209J	45	1.7717	85	3.3465	20.75	0.8169	19	0.7480	16	0.6299	0.06	2.205	2.087	2.992
HR30210J	50	1.9685	90	3.5433	21.75	0.8563	20	0.7874	17	0.6693	0.06	2.402	2.283	3.189
HR30211J	55	2.1654	100	3.9370	22.75	0.8957	21	0.8268	18	0.7087	0.06	2.638	2.520	3.583
HR30212J	60	2.3622	110	4.3307	23.75	0.9350	22	0.8661	19	0.7480	0.06	2.835	2.717	3.976
HR30213J	65	2.5591	120	4.7244	24.75	0.9744	23	0.9055	20	0.7874	0.06	3.031	3.071	4.370
HR30214J	70	2.7559	125	4.9213	26.25	1.0335	24	0.9449	21	0.8268	0.06	3.228	3.189	4.567
HR30215J	75	2.9528	130	5.1181	27.25	1.0728	25	0.9843	22	0.8661	0.06	3.425	3.346	4.764
HR30216J	80	3.1496	140	5.5118	28.25	1.1122	26	1.0236	22	0.8661	0.08	3.740	3.583	5.118
HR30217J	85	3.3465	150	5.9055	30.5	1.2008	28	1.1024	24	0.9449	0.08	3.937	3.819	5.512
HR30218J	90	3.5433	160	6.2992	32.5	1.2795	30	1.1811	26	1.0236	0.08	4.134	4.055	5.906
HR30219J	95	3.7402	170	6.6929	34.5	1.3583	32	1.2598	27	1.0630	0.08	4.449	4.331	6.220
HR30220J	100	3.9370	180	7.0866	37	1.4567	34	1.3386	29	1.1417	0.08	4.646	4.567	6.614
HR30221J	105	4.1339	190	7.4803	39	1.5354	36	1.4173	30	1.1811	0.08	4.843	4.843	7.008
HR30222J	110	4.3307	200	7.8740	41	1.6142	38	1.4961	32	1.2598	0.08	5.039	5.079	7.402
HR30224J	120	4.7244	215	8.4646	43.5	1.7126	40	1.5748	34	1.3386	0.08	5.433	5.551	7.992
HR30226J	130	5.1181	230	9.0551	43.75	1.7224	40	1.5748	34	1.3386	0.10	5.945	5.945	8.504
HR30228J	140	5.5118	250	9.8425	45.75	1.8012	42	1.6535	36	1.4173	0.10	6.339	6.457	9.291
30230	150	5.9055	270	10.6299	49	1.9291	45	1.7717	38	1.4961	0.10	6.732	6.929	10.079
30232	160	6.2992	290	11.4173	52	2.0472	48	1.8898	40	1.5748	0.10	7.126	7.559	10.866
30234	170	6.6929	310	12.2047	57	2.2441	52	2.0472	43	1.6929	0.12	7.756	7.992	11.496
30236	180	7.0866	320	12.5984	57	2.2441	52	2.0472	43	1.6929	0.12	8.150	8.386	11.890
30238	190	7.4803	340	13.3858	60	2.3622	55	2.1654	46	1.8110	0.12	8.543	8.976	12.677
30240	200	7.8740	360	14.1732	64	2.5197	58	2.2835	48	1.8898	0.12	8.937	9.528	13.465
30244	220	8.6614	400	15.7480	72	2.8346	68	2.6772	54	2.1260	0.12	9.724	10.512	15.039
30248	240	9.4488	440	17.3228	79	3.1102	72	2.8346	60	2.3622	0.12	10.512	11.339	16.614
30252	260	10.2362	480	18.8976	89	3.5039	80	3.1496	67	2.6378	0.16	11.535	12.441	18.031
30256	280	11.0236	500	19.6850	89	3.5039	80	3.1496	67	2.6378	0.16	12.323	13.346	18.819
30260	300	11.8110	540	21.2598	96	3.7795	85	3.3465	71	2.7953	0.16	13.110	13.976	20.394
30264	320	12.5984	580	22.8346	104	4.0945	92	3.6220	75	2.9528	0.16	13.898	15.000	21.969

*Maximum fillet which corner radius of bearing will clear.

Application Data

Bearing Tolerances — Table 10.17 thru Table 10.21 on page 318-21
 Shaft & Housing Fits — Table 10.31 on page 328

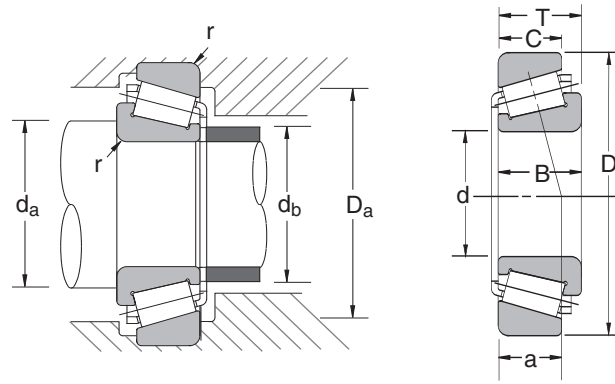

Bearing Number	Basic Load Ratings (lbs)		Limiting Speeds (1000 RPM)		Effective Load Center (inches)	Bearing Weight (Approx.)
	C_r	C_{or}	Grease	Oil	a	lbs
HR30202	3530	3210	11.00	15.00	0.32	0.12
HR30203J	4520	4470	9.50	13.00	0.38	0.17
HR30204J	6270	6410	8.00	11.00	0.43	0.28
HR30205J	7190	7870	7.10	10.00	0.50	0.35
HR30206J	9670	10700	6.00	8.00	0.55	0.52
HR30207J	12100	13400	5.30	7.10	0.59	0.75
HR30208J	14300	15700	4.80	6.30	0.65	0.97
HR30209J	15400	17900	4.30	6.00	0.72	1.08
HR30210J	17100	20600	4.00	5.30	0.77	1.23
HR30211J	21200	25400	3.60	5.00	0.82	1.62
HR30212J	23400	27700	3.40	4.50	0.87	2.05
HR30213J	27400	33900	3.00	4.00	0.94	2.60
HR30214J	29700	36600	2.80	4.00	1.01	2.87
HR30215J	32100	40900	2.80	3.80	1.06	3.15
HR30216J	35300	43800	2.60	3.40	1.11	3.73
HR30217J	41400	52400	2.40	3.20	1.19	4.67
HR30218J	45200	57600	2.20	3.00	1.25	5.73
HR30219J	50100	64300	2.20	2.80	1.33	6.90
HR30220J	57300	74200	2.00	2.60	1.42	8.33
HR30221J	62900	82100	1.90	2.60	1.50	9.94
HR30222J	70800	94400	1.80	2.40	1.58	11.64
HR30224J	75300	101000	1.60	2.20	1.75	13.85
HR30226J	84300	114000	1.50	2.00	1.80	15.99
HR30228J	87700	116000	1.40	1.90	1.93	19.27
30230	97800	128000	1.30	1.70	1.98	23.59
30232	106000	137000	1.20	1.60	2.17	28.89
30234	118000	155000	1.10	1.50	2.35	35.50
30236	117000	156000	1.10	1.40	2.44	36.60
30238	130000	178000	1.00	1.30	2.47	44.32
30240	145000	200000	0.90	1.30	2.58	52.48
30244	182000	259000	0.85	1.10	2.94	74.09
30248	223000	315000	0.75	1.00	3.35	99.67
30252	268000	382000	0.67	0.90	3.72	133.84
30256	279000	427000	0.63	0.85	3.88	146.19
30260	324000	472000	0.60	0.80	4.14	177.72
30264	369000	544000	0.53	0.75	4.48	218.96

C_r = Dynamic Radial Load Rating
 C_{or} = Static Radial Load Rating

Introduction

Ball Bearings

Cylindrical Roller Bearings

Spherical Roller Bearings

Tapered Roller Bearings

Thrust Bearings

Split Pillow Blocks

Super Precision Bearings

Linear Motion

Rolling Mill Bearings

Engineering Section



Tapered Roller Bearings

30300 Metric Series

Bore Diameter 15 – 260 mm

0.5906 – 10.2362 inch

Bearing Number	Nominal Bearing Dimensions										Preferred Shoulder Diameters (in)			
	<i>d</i>		<i>D</i>		<i>T</i>		<i>B</i>		<i>C</i>		<i>r</i> *	<i>d_a</i> (min)	<i>d_b</i> (max)	<i>D_a</i> (max)
	mm	inch	mm	inch	mm	inch	mm	inch	mm	inch				
HR30302J	15	0.5906	42	1.6535	14.25	0.5610	13	0.5118	11	0.4331	0.04	0.945	0.866	1.417
HR30303J	17	0.6693	47	1.8504	15.25	0.6004	14	0.5512	12	0.4724	0.04	1.024	0.945	1.614
HR30304J	20	0.7874	52	2.0472	16.25	0.6398	15	0.5906	13	0.5118	0.06	1.220	1.063	1.732
HR303/22	22	0.8661	56	2.2047	17.25	0.6791	16	0.6299	14	0.5512	0.06	1.280	1.197	1.850
HR30305J	25	0.9843	62	2.4409	18.25	0.7185	17	0.6693	15	0.5906	0.06	1.417	1.339	2.126
HR303/28	28	1.1024	68	2.6772	19.75	0.7776	18	0.7087	15	0.5906	0.06	1.535	1.457	2.323
HR30306J	30	1.1811	72	2.8346	20.75	0.8169	19	0.7480	16	0.6299	0.06	1.614	1.575	2.480
HR303/32	32	1.2598	75	2.9528	21.75	0.8563	20	0.7874	17	0.6693	0.06	1.693	1.654	2.598
HR30307J	35	1.3780	80	3.1496	22.75	0.8957	21	0.8268	18	0.7087	0.06	1.850	1.772	2.795
HR30308J	40	1.5748	90	3.5433	25.25	0.9941	23	0.9055	20	0.7874	0.06	2.047	2.047	3.189
HR30309J	45	1.7717	100	3.9370	27.25	1.0728	25	0.9843	22	0.8661	0.06	2.244	2.283	3.583
HR30310J	50	1.9685	110	4.3307	29.25	1.1516	27	1.0630	23	0.9055	0.08	2.559	2.559	3.937
HR30311J	55	2.1654	120	4.7244	31.5	1.2402	29	1.1417	25	0.9843	0.08	2.756	2.795	4.331
HR30312J	60	2.3622	130	5.1181	33.5	1.3189	31	1.2205	26	1.0236	0.10	3.071	3.031	4.646
HR30313J	65	2.5591	140	5.5118	36	1.4173	33	1.2992	28	1.1024	0.10	3.268	3.268	5.039
HR30314J	70	2.7559	150	5.9055	38	1.4961	35	1.3780	30	1.1811	0.10	3.465	3.504	5.433
HR30315J	75	2.9528	160	6.2992	40	1.5748	37	1.4567	31	1.2205	0.10	3.661	3.740	5.827
HR30316J	80	3.1496	170	6.6929	42.5	1.6732	39	1.5354	33	1.2992	0.10	3.858	4.016	6.220
HR30317J	85	3.3465	180	7.0866	44.5	1.7520	41	1.6142	34	1.3386	0.10	4.173	4.252	6.535
HR30318J	90	3.5433	190	7.4803	46.5	1.8307	43	1.6929	36	1.4173	0.10	4.252	4.500	7.087
HR30319J	95	3.7402	200	7.8740	49.5	1.9488	45	1.7717	38	1.4961	0.10	4.449	4.685	7.480
HR30320J	100	3.9370	215	8.4646	51.5	2.0276	47	1.8504	39	1.5354	0.10	4.646	5.039	7.913
HR30321J	105	4.1339	225	8.8583	53.5	2.1063	49	1.9291	41	1.6142	0.10	4.843	5.272	8.307
HR30322J	110	4.3307	240	9.4488	54.5	2.1457	50	1.9685	42	1.6535	0.10	5.039	5.638	8.898
HR30324J	120	4.7244	260	10.2362	59.5	2.3425	55	2.1654	46	1.8110	0.10	5.433	6.067	9.685
30326	130	5.1181	280	11.0236	63.75	2.5098	58	2.2835	49	1.9291	0.12	6.181	6.614	10.315
30328	140	5.5118	300	11.8110	67.75	2.6673	62	2.4409	53	2.0866	0.12	6.575	7.087	11.102
30330	150	5.9055	320	12.5984	72	2.8346	65	2.5591	55	2.1654	0.12	6.969	7.598	11.890
30332	160	6.2992	340	13.3858	75	2.9528	68	2.6772	58	2.2835	0.12	7.362	8.071	12.677
30334	170	6.6929	360	14.1732	80	3.1496	72	2.8346	62	2.4409	0.12	7.756	8.701	13.465
30336	180	7.0866	380	14.9606	83	3.2677	75	2.9528	64	2.5197	0.12	8.150	9.173	14.252
30338	190	7.4803	400	15.7480	86	3.3858	78	3.0709	65	2.5591	0.16	8.780	9.764	14.882
30340	200	7.8740	420	16.5354	89	3.5039	80	3.1496	67	2.6378	0.16	9.173	9.961	15.669
30344	220	8.6614	460	18.1102	97	3.8189	88	3.4646	73	2.8740	0.16	9.961	11.142	17.244
30348	240	9.4488	500	19.6850	105	4.1339	95	3.7402	80	3.1496	0.16	10.748	12.126	18.819
30352	260	10.2362	540	21.2598	113	4.4488	102	4.0157	85	3.3465	0.16	11.299	13.228	20.394

*Maximum fillet which corner radius of bearing will clear.

Application Data

Bearing Tolerances — Table 10.17 thru Table 10.21 on page 318-21
 Shaft & Housing Fits — Table 10.31 on page 328

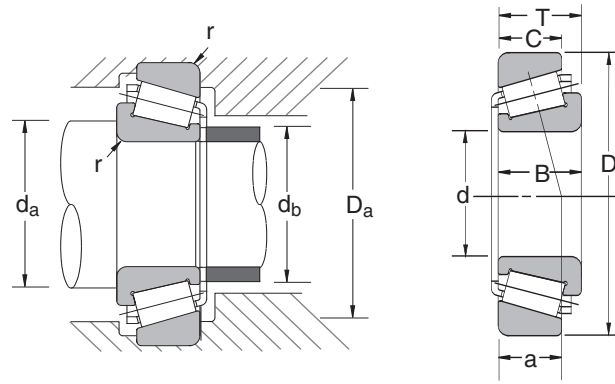

Bearing Number	Basic Load Ratings (lbs)		Limiting Speeds (1000 RPM)		Effective Load Center (inches)	Bearing Weight (Approx.)
	C_r	C_{or}	Grease	Oil	a	lbs
HR30302J	5310	4740	9.50	13.00	0.37	0.22
HR30303J	6560	6000	8.50	12.00	0.41	0.30
HR30304J	7870	7530	7.50	10.00	0.46	0.38
HR303/22	8320	8210	7.16	9.71	0.49	0.46
HR30305J	10700	10300	6.30	8.50	0.52	0.59
HR303/28	12400	12500	6.00	8.00	0.57	0.75
HR30306J	13400	13500	5.30	7.50	0.59	0.89
HR303/32	14600	15600	5.30	7.10	0.63	0.98
HR30307J	17100	17800	4.80	6.70	0.66	1.19
HR30308J	20300	22700	4.30	5.60	0.77	1.67
HR30309J	25200	28600	3.80	5.30	0.83	2.23
HR30310J	29200	33300	3.40	4.80	0.91	2.82
HR30311J	33700	38400	3.20	4.30	0.97	3.59
HR30312J	39100	45200	3.00	4.00	1.02	4.48
HR30313J	45000	52400	2.60	3.60	1.10	5.53
HR30314J	51000	60200	2.40	3.40	1.17	6.68
HR30315J	56900	67400	2.40	3.20	1.25	8.00
HR30316J	62000	74200	2.20	3.00	1.34	9.42
HR30317J	69700	84300	2.00	2.80	1.41	11.20
HR30318J	77600	95500	1.94	2.64	1.47	13.04
HR30319J	83200	102000	1.86	2.53	1.52	15.25
HR30320J	95500	118000	1.72	2.34	1.63	18.54
HR30321J	102000	127000	1.64	2.23	1.70	21.00
HR30322J	109000	134000	1.53	2.08	1.77	24.29
HR30324J	120000	147000	1.41	1.92	1.97	30.69
30326	123000	152000	1.30	1.80	2.12	36.60
30328	135000	166000	1.20	1.60	2.26	44.32
30330	155000	193000	1.10	1.50	2.42	53.36
30332	172000	216000	1.00	1.40	2.54	62.62
30334	190000	243000	0.95	1.30	2.76	73.87
30336	210000	277000	0.90	1.30	2.85	86.66
30338	227000	301000	0.85	1.20	3.00	101.43
30340	232000	312000	0.85	1.20	3.20	115.32
30344	321000	447000	0.75	1.00	3.36	159.64
30348	373000	526000	0.67	0.95	3.65	204.18
30352	420000	593000	0.62	0.84	4.00	251.98

C_r = Dynamic Radial Load Rating
 C_{or} = Static Radial Load Rating

Introduction

Ball Bearings

Cylindrical Roller Bearings

Spherical Roller Bearings

Tapered Roller Bearings

Thrust Bearings

Split Pillow Blocks

Super Precision Bearings

Linear Motion

Rolling Mill Bearings

Engineering Section



Tapered Roller Bearings

31300 Metric Series

Bore Diameter 25 – 150 mm

0.9843 – 5.9055 inch

Bearing Number	Nominal Bearing Dimensions										Preferred Shoulder Diameters (in)			
	<i>d</i>		<i>D</i>		<i>T</i>		<i>B</i>		<i>C</i>		<i>r</i> *	<i>d</i> _a (min)	<i>d</i> _b (max)	<i>D</i> _a (max)
	mm	inch	mm	inch	mm	inch	mm	inch	mm	inch				
HR31305J	25	0.9843	62	2.4409	18.25	0.7185	17	0.6693	13	0.5118	0.06	1.398	1.346	2.087
HR31306J	30	1.1811	72	2.8346	20.75	0.8169	19	0.7480	14	0.5512	0.06	1.594	1.575	2.480
HR31307J	35	1.3780	80	3.1496	22.75	0.8957	21	0.8268	15	0.5906	0.06	1.791	1.764	2.795
HR31308J	40	1.5748	90	3.5433	25.25	0.9941	23	0.9055	17	0.6693	0.06	1.988	2.000	3.189
HR31309J	45	1.7717	100	3.9370	27.25	1.0728	25	0.9843	18	0.7087	0.06	2.185	2.244	3.583
HR31310J	50	1.9685	110	4.3307	29.25	1.1516	27	1.0630	19	0.7480	0.08	2.441	2.465	3.937
HR31311J	55	2.1654	120	4.7244	31.5	1.2402	29	1.1417	21	0.8268	0.08	2.638	2.657	4.331
HR31312J	60	2.3622	130	5.1181	33.5	1.3189	31	1.2205	22	0.8661	0.08	2.953	2.929	4.646
HR31313J	65	2.5591	140	5.5118	36	1.4173	33	1.2992	23	0.9055	0.08	3.150	3.157	5.039
HR31314J	70	2.7559	150	5.9055	38	1.4961	35	1.3780	25	0.9843	0.08	3.346	3.366	5.433
HR31315J	75	2.9528	160	6.2992	40	1.5748	37	1.4567	26	1.0236	0.08	3.543	3.618	5.827
HR31316J	80	3.1496	170	6.6929	42.5	1.6732	39	1.5354	27	1.0630	0.08	3.740	3.823	6.220
HR31317J	85	3.3465	180	7.0866	44.5	1.7520	41	1.6142	28	1.1024	0.10	4.055	4.055	6.535
HR31318J	90	3.5433	190	7.4803	46.5	1.8307	43	1.6929	30	1.1811	0.10	4.252	4.339	6.929
HR31319J	95	3.7402	200	7.8740	49.5	1.9488	45	1.7717	32	1.2598	0.10	4.449	4.528	7.323
HR31320J	100	3.9370	215	8.4646	51.5	2.0276	47	1.8504	34	1.3386	0.10	4.646	7.913	7.913
HR31321J	105	4.1339	225	8.8583	53.5	2.1063	49	1.9291	35	1.3780	0.10	4.843	8.307	8.307
HR31322J	110	4.3307	240	9.4488	54.5	2.1457	50	1.9685	36	1.4173	0.10	5.039	8.898	8.898
HR31324J	120	4.7244	260	10.2362	68	2.6771	62	2.4409	42	1.6535	0.10	5.433	9.685	9.685
HR31326J	130	5.1181	280	11.0236	63.75	2.5098	58	2.2835	39	1.5354	0.12	5.945	10.315	10.315
HR31328J	140	5.5118	300	11.8110	67.75	2.6673	62	2.4409	43	1.6929	0.12	6.339	11.102	11.102
HR31330J	150	5.9055	320	12.5984	72	2.8346	65	2.5591	45	1.7717	0.12	6.732	11.890	11.890

*Maximum fillet which corner radius of bearing will clear.

Application Data

Bearing Tolerances — Table 10.17 thru Table 10.21 on page 318-21
 Shaft & Housing Fits — Table 10.31 on page 328

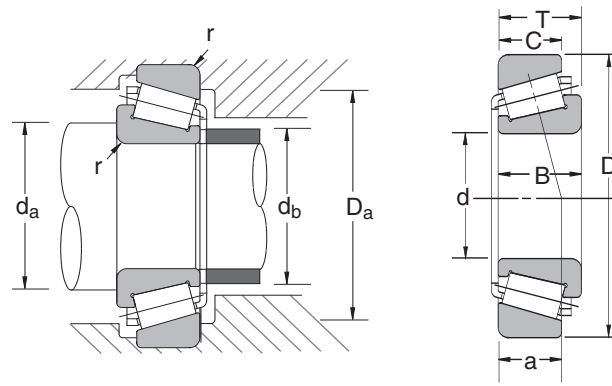

Bearing Number	Basic Load Ratings (lbs)		Limiting Speeds (1000 RPM)		Effective Load Center (inches)	Bearing Weight (Approx.)
	C_r	C_{or}	Grease	Oil	a	lbs
HR31305J	8540	9100	6.41	8.70	0.78	0.58
HR31306J	11000	11800	5.48	7.44	0.91	0.87
HR31307J	13900	15300	4.88	6.63	0.99	1.15
HR31308J	18000	20100	4.29	5.82	1.13	1.61
HR31309J	21500	24500	3.85	5.23	1.24	1.61
HR31310J	25600	29700	3.51	4.76	1.35	2.77
HR31311J	29400	34400	3.25	4.41	1.46	3.48
HR31312J	33900	39800	2.97	4.03	1.58	4.37
HR31313J	38900	46100	2.75	3.73	1.70	5.36
HR31314J	43200	51500	2.57	3.49	1.80	6.48
HR31315J	47400	56400	2.39	3.25	1.92	7.66
HR31316J	52800	63600	2.25	3.06	2.04	8.96
HR31317J	58700	70800	2.11	2.86	2.18	10.76
HR31318J	59300	70800	1.98	2.69	2.31	12.17
HR31319J	69700	84300	1.89	2.57	2.44	14.63
HR31320J	67200	114000	1.73	2.35	2.66	19.89
HR31321J	76400	121000	1.65	2.25	2.76	22.14
HR31322J	76400	136000	1.56	2.11	2.94	27.02
HR31324J	95500	164000	1.43	1.94	3.21	34.49
HR31326J	111300	184000	1.32	1.80	3.43	41.45
HR31328J	124800	215000	1.21	1.65	3.65	51.20
HR31330J	137100	247000	1.13	1.53	3.91	62.78

C_r = Dynamic Radial Load Rating
 C_{or} = Static Radial Load Rating



Tapered Roller Bearings

32000 Metric Series

Bore Diameter 20 – 320 mm

0.7874 – 12.5984 inch

Bearing Number	Nominal Bearing Dimensions										Preferred Shoulder Diameters (in)			
	<i>d</i>		<i>D</i>		<i>T</i>		<i>B</i>		<i>C</i>		<i>r</i> *	<i>d</i> _a (min)	<i>d</i> _b (max)	<i>D</i> _a (max)
	mm	inch	mm	inch	mm	inch	mm	inch	mm	inch				
HR32004XJ	20	0.7874	42	1.6535	15	0.5906	15	0.5906	12	0.4724	0.02	1.102	0.945	1.457
HR320/22XJ	22	0.8661	44	1.7323	15	0.5906	15	0.5906	11.5	0.4528	0.02	1.182	1.064	1.537
HR32005XJ	25	0.9843	47	1.8504	15	0.5906	15	0.5906	11.5	0.4528	0.02	1.299	1.181	1.654
HR320/28XJ	28	1.1024	52	2.0472	16	0.6299	16	0.6299	12	0.4724	0.04	1.457	1.299	1.811
HR32006XJ	30	1.1811	55	2.1654	17	0.6693	17	0.6693	13	0.5118	0.04	1.535	1.378	1.929
HR320/32XJ	32	1.2598	58	2.2835	17	0.6693	17	0.6693	13	0.5118	0.04	1.614	1.457	2.047
HR32007XJ	35	1.3780	62	2.4409	18	0.7087	18	0.7087	14	0.5512	0.04	1.732	1.575	2.205
HR32008XJ	40	1.5748	68	2.6772	19	0.7480	19	0.7480	14.5	0.5709	0.04	1.929	1.772	2.441
HR32009XJ	45	1.7717	75	2.9528	20	0.7874	20	0.7874	15.5	0.6102	0.04	2.126	2.008	2.717
HR32010XJ	50	1.9685	80	3.1496	20	0.7874	20	0.7874	15.5	0.6102	0.04	2.323	2.205	2.913
HR32011XJ	55	2.1654	90	3.5433	23	0.9055	23	0.9055	17.5	0.6890	0.06	2.598	2.441	3.189
HR32012XJ	60	2.3622	95	3.7402	23	0.9055	23	0.9055	17.5	0.6890	0.06	2.795	2.598	3.386
HR32013XJ	65	2.5591	100	3.9370	23	0.9055	23	0.9055	17.5	0.6890	0.06	2.992	2.795	3.583
HR32014XJ	70	2.7559	110	4.3307	25	0.9843	25	0.9843	19	0.7480	0.06	3.189	3.031	3.976
HR32015XJ	75	2.9528	115	4.5276	25	0.9843	25	0.9843	19	0.7480	0.06	3.386	3.228	4.173
HR32016XJ	80	3.1496	125	4.9213	29	1.1417	29	1.1417	22	0.8661	0.06	3.583	3.504	4.567
HR32017XJ	85	3.3465	130	5.1181	29	1.1417	29	1.1417	22	0.8661	0.06	3.780	3.701	4.764
HR32018XJ	90	3.5433	140	5.5118	32	1.2598	32	1.2598	24	0.9449	0.06	4.016	3.898	5.157
HR32019XJ	95	3.7402	145	5.7087	32	1.2598	32	1.2598	24	0.9449	0.06	4.213	4.094	5.354
HR32020XJ	100	3.9370	150	5.9055	32	1.2598	32	1.2598	24	0.9449	0.06	4.409	4.291	5.551
HR32021XJ	105	4.1339	160	6.2992	35	1.3780	35	1.3780	26	1.0236	0.08	4.724	4.528	5.906
HR32022XJ	110	4.3307	170	6.6929	38	1.4961	38	1.4961	29	1.1417	0.08	4.921	4.764	6.299
HR32024XJ	120	4.7244	180	7.0866	38	1.4961	38	1.4961	29	1.1417	0.08	5.315	5.157	6.693
HR32026XJ	130	5.1181	200	7.8740	45	1.7717	45	1.7717	34	1.3386	0.08	5.709	5.669	7.480
HR32028XJ	140	5.5118	210	8.2677	45	1.7717	45	1.7717	34	1.3386	0.08	6.102	5.984	7.874
HR32030XJ	150	5.9055	225	8.8583	48	1.8898	48	1.8898	36	1.4173	0.08	6.614	6.457	8.386
HR32032XJ	160	6.2992	240	9.4488	51	2.0079	51	2.0079	38	1.4961	0.08	7.008	6.890	8.976
HR32034XJ	170	6.6929	260	10.2362	57	2.2441	57	2.2441	43	1.6929	0.08	7.402	7.362	9.764
HR32036XJ	180	7.0866	280	11.0236	64	2.5197	64	2.5197	48	1.8898	0.08	7.795	7.835	10.551
HR32038XJ	190	7.4803	290	11.4173	64	2.5197	64	2.5197	48	1.8898	0.08	8.189	8.228	10.945
HR32040XJ	200	7.8740	310	12.2047	70	2.7559	70	2.7559	53	2.0866	0.08	8.583	8.701	11.732
HR32044XJ	220	8.6614	340	13.3858	76	2.9921	76	2.9921	57	2.2441	0.12	9.488	9.606	12.835
HR32048XJ	240	9.4488	360	14.1732	76	2.9921	76	2.9921	57	2.2441	0.12	10.276	10.315	13.622
HR32052XJ	260	10.2362	400	15.7480	87	3.4252	87	3.4252	65	2.5591	0.12	11.299	11.299	15.039
HR32056XJ	280	11.0236	420	16.5354	87	3.4252	87	3.4252	65	2.5591	0.12	12.087	12.008	15.827
HR32060XJ	300	11.8110	460	18.1102	100	3.9370	100	3.9370	74	2.9134	0.12	12.874	12.992	17.402
HR32064XJ	320	12.5984	480	18.8976	100	3.9370	100	3.9370	74	2.9134	0.12	13.661	13.780	18.189

*Maximum fillet which corner radius of bearing will clear.

Application Data

Bearing Tolerances — Table 10.17 thru Table 10.21 on page 318-21
 Shaft & Housing Fits — Table 10.31 on page 328

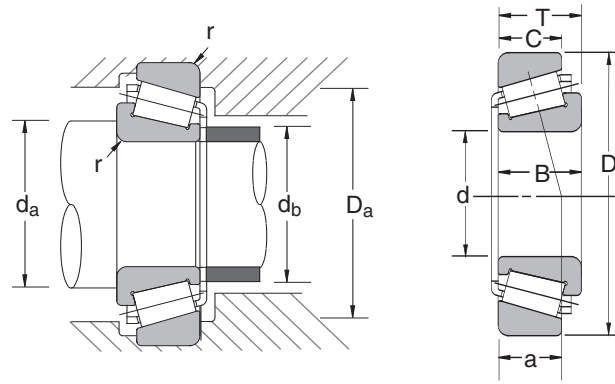

Bearing Number	Basic Load Ratings (lbs)		Limiting Speeds (1000 RPM)		Effective Load Center (inches)	Bearing Weight (Approx.)
	C_r	C_{or}	Grease	Oil	a	lbs
HR32004XJ	24600	6160	9.00	12.00	0.42	0.21
HR320/22XJ	25600	6610	8.50	11.00	0.44	0.23
HR32005XJ	27400	7420	8.00	11.00	0.46	0.26
HR320/28XJ	32000	8770	7.10	9.50	0.50	0.32
HR32006XJ	36000	10000	6.70	9.00	0.53	0.38
HR320/32XJ	37500	10600	6.30	8.50	0.56	0.42
HR32007XJ	43500	12500	5.60	8.00	0.59	0.51
HR32008XJ	52500	16000	5.30	7.10	0.59	0.62
HR32009XJ	60000	18700	4.50	6.30	0.65	0.78
HR32010XJ	61000	19600	4.30	6.00	0.70	0.84
HR32011XJ	81500	26300	3.80	5.30	0.78	1.25
HR32012XJ	85500	28600	3.60	5.00	0.82	1.34
HR32013XJ	86500	29700	3.40	4.50	0.88	1.42
HR32014XJ	104000	35500	3.20	4.30	0.93	1.92
HR32015XJ	109000	38400	3.00	4.00	0.99	2.04
HR32016XJ	140000	49900	2.80	3.60	1.06	2.91
HR32017XJ	143000	51900	2.60	3.60	1.11	3.04
HR32018XJ	170000	61400	2.40	3.20	1.17	3.92
HR32019XJ	173000	63600	2.40	3.20	1.23	4.15
HR32020XJ	176000	66100	2.20	3.00	1.28	4.30
HR32021XJ	204000	76400	2.00	2.80	1.35	5.47
HR32022XJ	236000	87700	2.00	2.60	1.41	6.81
HR32024XJ	242000	91000	1.80	2.40	1.56	7.21
HR32026XJ	320000	120000	1.60	2.20	1.73	11.16
HR32028XJ	325000	125000	1.60	2.20	1.83	11.73
HR32030XJ	375000	146000	1.40	2.00	1.96	14.55
HR32032XJ	425000	169000	1.30	1.80	2.09	17.49
HR32034XJ	505000	200000	1.20	1.70	2.23	23.37
HR32036XJ	640000	254000	1.20	1.60	2.38	31.53
HR32038XJ	650000	263000	1.10	1.50	2.49	32.85
HR32040XJ	760000	308000	1.00	1.40	2.65	41.67
HR32044XJ	885000	362000	0.95	1.30	2.90	53.80
HR32048XJ	920000	389000	0.85	1.20	3.11	57.77
HR32052XJ	1160000	486000	0.80	1.10	3.40	84.89
HR32056XJ	1180000	504000	0.71	1.00	3.61	89.52
HR32060XJ	1440000	607000	0.67	0.90	3.87	124.80
HR32064XJ	1510000	654000	0.63	0.85	4.11	132.30

C_r = Dynamic Radial Load Rating
 C_{or} = Static Radial Load Rating

Introduction

Ball Bearings

Cylindrical Roller Bearings

Spherical Roller Bearings

Tapered Roller Bearings

Thrust Bearings

Split Pillow Blocks

Super Precision Bearings

Linear Motion

Rolling Mill Bearings

Engineering Section



Tapered Roller Bearings

32200 Metric Series

Bore Diameter 17 – 320 mm

0.6693 – 12.5984 inch

Bearing Number	Nominal Bearing Dimensions										Preferred Shoulder Diameters (in)			
	<i>d</i>		<i>D</i>		<i>T</i>		<i>B</i>		<i>C</i>		<i>r</i> *	<i>d_a</i> (min)	<i>d_b</i> (max)	<i>D_a</i> (max)
	mm	inch	mm	inch	mm	inch	mm	inch	mm	inch				
HR32203J	17	0.6693	40	1.5748	17.25	0.6791	16	0.6299	14	0.5512	1.00	1.024	0.874	1.339
HR32204J	20	0.7874	47	1.8504	19.25	0.7579	18	0.7087	15	0.5906	1.00	1.142	0.996	1.614
HR322/22	22	0.8661	50	1.9685	19.25	0.7579	18	0.7087	15	0.5906	1.00	1.220	1.118	1.732
HR32205J	25	0.9843	52	2.0472	19.25	0.7579	18	0.7087	16	0.6299	1.00	1.339	1.213	1.811
HR322/28	28	1.1024	58	2.2835	20.25	0.7972	19	0.7480	16	0.6299	1.00	1.457	1.358	0.000
HR32206J	30	1.1811	62	2.4409	21.25	0.8366	20	0.7874	17	0.6693	1.00	1.535	1.449	2.205
HR322/32	32	1.2598	75	2.9528	21.75	0.8563	20	0.7874	17	0.6693	1.00	1.614	1.504	0.000
HR32207J	35	1.3780	72	2.8346	24.25	0.9547	23	0.9055	19	0.7480	1.50	1.791	1.685	2.480
HR32208J	40	1.5748	80	3.1496	24.75	0.9744	23	0.9055	19	0.7480	1.50	1.988	1.909	2.795
HR32209J	45	1.7717	85	3.3465	24.75	0.9744	23	0.9055	19	0.7480	1.50	2.185	2.106	2.992
HR32210J	50	1.9685	90	3.5433	24.75	0.9744	23	0.9055	19	0.7480	1.50	2.382	2.272	3.189
HR32211J	55	2.1654	100	3.9370	26.75	1.0531	25	0.9843	21	0.8268	1.50	2.579	2.496	3.583
HR32212J	60	2.3622	110	4.3307	29.75	1.1713	28	1.1024	24	0.9449	1.50	2.776	2.705	3.976
HR32213J	65	2.5591	120	4.7244	32.75	1.2894	31	1.2205	27	1.0630	1.50	2.972	2.953	4.370
HR32214J	70	2.7559	125	4.9213	33.25	1.3091	31	1.2205	27	1.0630	1.50	3.169	3.150	4.567
HR32215J	75	2.9528	130	5.1181	33.25	1.3091	31	1.2205	27	1.0630	1.50	3.366	3.307	4.764
HR32216J	80	3.1496	140	5.5118	35.25	1.3878	33	1.2992	28	1.1024	2.00	3.622	3.543	5.118
HR32217J	85	3.3465	150	5.9055	38.5	1.5157	36	1.4173	30	1.1811	2.00	3.819	3.780	5.512
HR32218J	90	3.5433	160	6.2992	42.5	1.6732	40	1.5748	34	1.3386	2.00	4.016	4.016	5.906
HR32219J	95	3.7402	170	6.6929	45.5	1.7913	43	1.6929	37	1.4567	2.00	4.331	4.252	6.220
HR32220J	100	3.9370	180	7.0866	49	1.9291	46	1.8110	39	1.5354	2.00	4.528	4.528	6.614
HR32221J	105	4.1339	190	7.4803	53	2.0866	50	1.9685	43	1.6929	2.00	4.724	4.724	7.008
HR32222J	110	4.3307	200	7.8740	56	2.2047	53	2.0866	46	1.8110	2.00	4.921	5.000	7.402
HR32224J	120	4.7244	215	8.4646	61.5	2.4213	58	2.2835	50	1.9685	2.00	5.315	5.394	7.992
HR32226J	130	5.1181	230	9.0551	67.75	2.6673	64	2.5197	54	2.1260	2.50	5.827	5.787	8.504
HR32228J	140	5.5118	250	9.8425	71.75	2.8248	68	2.6772	58	2.2835	2.50	6.220	6.260	9.291
HR32230J	150	5.9055	270	10.6299	77	3.0315	73	2.8740	60	2.3622	2.50	6.614	6.732	10.079
HR32232J	160	6.2992	290	11.4173	84	3.3071	80	3.1496	67	2.6378	2.50	7.008	7.252	10.866
HR32234J	170	6.6929	310	12.2047	91	3.5827	86	3.3858	71	2.7953	3.00	7.520	7.756	11.496
HR32236J	180	7.0866	320	12.5984	91	3.5827	86	3.3858	71	2.7953	3.00	7.913	8.091	11.890
HR32238J	190	7.4803	340	13.3858	97	3.8189	92	3.6220	75	2.9528	3.00	8.307	8.528	12.835
HR32240J	200	7.8740	360	14.1732	104	4.0945	98	3.8583	82	3.2283	3.00	8.701	9.075	13.465
HR32244J	220	8.6614	400	15.7480	114	4.4882	108	4.2520	90	3.5433	3.00	9.724	10.118	14.882
32248	240	9.4488	440	17.3228	127	5.0000	120	4.7244	100	3.9370	3.00	10.512	11.220	16.457
32252	260	10.2362	480	18.8976	137	5.3937	130	5.1181	106	4.1732	4.00	11.535	12.008	17.795
32256	280	11.0236	500	19.6850	137	5.3937	130	5.1181	106	4.1732	4.00	12.323	12.795	18.583
32260	300	11.8110	540	21.2598	149	5.8661	140	5.5118	115	4.5276	4.00	13.110	13.858	20.157
32264	320	12.5984	580	22.8346	159	6.2598	150	5.9055	125	4.9213	4.00	13.898	15.079	21.732

*Maximum fillet which corner radius of bearing will clear.

Application Data

Bearing Tolerances — Table 10.17 thru Table 10.21 on page 318-21
 Shaft & Housing Fits — Table 10.31 on page 328

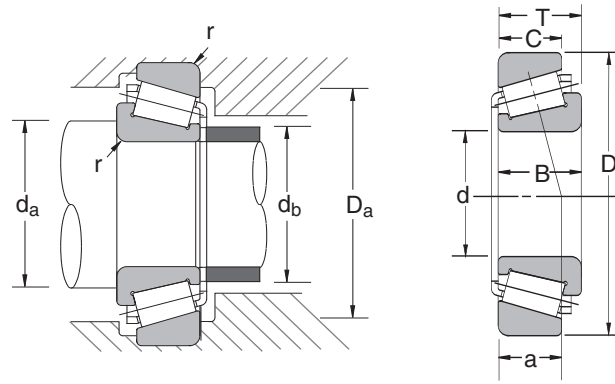

Bearing Number	Basic Load Ratings (lbs)		Limiting Speeds (1000 RPM)		Effective Load Center (inches)	Bearing Weight (Approx.)
	C_r	C_{or}	Grease	Oil	a	lbs
HR32203J	6090	6290	9.72	13.20	0.44	0.23
HR32204J	7980	8430	8.47	11.49	0.50	0.36
HR322/22	8210	9100	7.75	10.51	0.53	0.40
HR32205J	8990	10100	7.23	9.81	0.53	0.42
HR322/28	10700	12100	6.48	8.80	0.58	0.54
HR32206J	11700	13500	6.10	8.28	0.61	0.65
HR322/32	12600	14600	5.87	7.97	0.62	0.74
HR32207J	15800	18800	5.30	7.10	0.70	1.01
HR32208J	17300	20300	4.80	6.30	0.74	1.21
HR32209J	18700	22900	4.30	6.00	0.79	1.33
HR32210J	19700	24500	4.00	5.30	0.83	1.42
HR32211J	24700	30800	3.60	5.00	0.89	1.90
HR32212J	29400	37500	3.40	4.50	0.95	2.60
HR32213J	35300	45400	3.00	4.00	1.07	3.42
HR32214J	35300	46100	2.80	4.00	1.13	3.65
HR32215J	37100	49200	2.80	3.80	1.17	3.80
HR32216J	43200	57100	2.60	3.40	1.20	4.70
HR32217J	47200	62300	2.40	3.20	1.33	5.81
HR32218J	57600	78700	2.20	3.00	1.42	7.52
HR32219J	65000	89900	2.20	2.80	1.55	9.30
HR32220J	73100	101000	2.00	2.60	1.63	11.14
HR32221J	80900	115000	1.90	2.60	1.76	13.78
HR32222J	89900	127000	1.80	2.40	1.86	16.20
HR32224J	98900	143000	1.60	2.20	2.05	19.85
HR32226J	119000	178000	1.50	2.00	2.24	25.02
HR32228J	137000	206000	1.40	1.90	2.38	31.43
HR32230J	158000	243000	1.29	1.75	2.55	39.36
HR32232J	179000	274000	1.20	1.62	2.78	49.96
HR32234J	209000	326000	1.11	1.50	3.01	61.75
HR32236J	216000	346000	1.06	1.44	3.10	65.71
HR32238J	250000	398000	1.00	1.35	3.17	77.56
HR32240J	272000	432000	0.94	1.27	3.35	94.01
HR32244J	326000	526000	0.83	1.13	3.80	130.97
32248	366000	614000	0.74	1.01	4.03	172.07
32252	427000	742000	0.69	0.93	4.57	226.60
32256	438000	776000	0.65	0.88	4.84	240.82
32260	499000	832000	0.58	0.79	5.18	290.61
32264	643000	1140000	0.54	0.73	5.58	384.80

C_r = Dynamic Radial Load Rating
 C_{or} = Static Radial Load Rating

Introduction

Ball Bearings

Cylindrical Roller Bearings

Spherical Roller Bearings

Tapered Roller Bearings

Thrust Bearings

Split Pillow Blocks

Super Precision Bearings

Linear Motion

Rolling Mill Bearings

Engineering Section



Tapered Roller Bearings

32300 Metric Series

Bore Diameter 17 – 240 mm

0.6693 – 9.4488 inch

Bearing Number	Nominal Bearing Dimensions										Preferred Shoulder Diameters (in)			
	<i>d</i>		<i>D</i>		<i>T</i>		<i>B</i>		<i>C</i>		<i>r</i> *	<i>d_a</i> (min)	<i>d_b</i> (max)	<i>D_a</i> (max)
	mm	inch	mm	inch	mm	inch	mm	inch	mm	inch				
32303	17	0.6693	47	1.8504	20.25	0.7972	19	0.7480	16	0.6299	0.04	1.024	0.941	1.614
HR32304J	20	0.7874	52	2.0472	22.25	0.8760	21	0.8268	18	0.7087	0.06	1.201	1.024	1.693
HR32305J	25	0.9843	62	2.4409	25.25	0.9941	24	0.9449	20	0.7874	0.06	1.496	1.260	2.087
HR32306J	30	1.1811	72	2.8346	28.75	1.1319	27	1.0630	23	0.9055	0.06	1.693	1.496	2.480
HR32307J	35	1.3780	80	3.1496	32.75	1.2894	31	1.2205	25	0.9843	0.06	1.929	1.693	2.795
HR32308J	40	1.5748	90	3.5433	35.25	1.3878	33	1.2992	27	1.0630	0.06	2.126	1.969	3.189
HR32309J	45	1.7717	100	3.9370	38.25	1.5059	36	1.4173	30	1.1811	0.06	2.323	2.205	3.583
HR32310J	50	1.9685	110	4.3307	42.25	1.6634	40	1.5748	33	1.2992	0.08	2.677	2.441	3.937
HR32311J	55	2.1654	120	4.7244	45.5	1.7913	43	1.6929	35	1.3780	0.08	2.874	2.638	4.331
HR32312J	60	2.3622	130	5.1181	48.5	1.9094	46	1.8110	37	1.4567	0.10	3.189	2.913	4.646
HR32313J	65	2.5591	140	5.5118	51	2.0079	48	1.8898	39	1.5354	0.10	3.386	3.150	5.039
HR32314J	70	2.7559	150	5.9055	54	2.1260	51	2.0079	42	1.6535	0.10	3.583	3.386	5.433
HR32315J	75	2.9528	160	6.2992	58	2.2835	55	2.1654	45	1.7717	0.10	3.780	3.583	5.827
HR32316J	80	3.1496	170	6.6929	61.5	2.4213	58	2.2835	48	1.8898	0.10	3.976	3.858	6.220
HR32317J	85	3.3465	180	7.0866	63.5	2.5000	60	2.3622	49	1.9291	0.12	4.331	4.094	6.535
HR32318J	90	3.5433	190	7.4803	67.5	2.6575	64	2.5197	53	2.0866	0.12	4.528	4.291	6.929
HR32319J	95	3.7402	200	7.8740	71.5	2.8150	67	2.6378	55	2.1654	0.12	4.685	4.528	7.480
HR32320J	100	3.9370	215	8.4646	77.5	3.0512	73	2.8740	60	2.3622	0.12	4.925	4.925	7.913
HR32321J	105	4.1339	225	8.8583	81.5	3.2087	77	3.0315	63	2.4803	0.12	5.118	5.039	8.465
HR32322J	110	4.3307	240	9.4488	84.5	3.3268	80	3.1496	65	2.5591	0.12	5.319	5.477	8.898
HR32324J	120	4.7244	260	10.2362	90.5	3.5630	86	3.3858	69	2.7165	0.12	5.713	9.692	9.685
32326	130	5.1181	280	11.0236	98.75	3.8878	93	3.6614	78	3.0709	0.12	6.378	6.496	10.315
32328	140	5.5118	300	11.8110	107.75	4.2421	102	4.0157	85	3.3465	0.12	6.772	6.969	11.102
32330	150	5.9055	320	12.5984	114	4.4882	108	4.2520	90	3.5433	0.12	7.165	7.520	11.890
32332	160	6.2992	340	13.3858	121	4.7638	114	4.4882	95	3.7402	0.12	7.559	7.953	12.677
32334	170	6.6929	360	14.1732	127	5.0000	120	4.7244	100	3.9370	0.12	7.953	8.386	13.465
32336	180	7.0866	380	14.9606	134	5.2756	126	4.9606	106	4.1732	0.12	8.346	8.858	14.252
32340	200	7.8740	420	16.5354	146	5.7480	138	5.4331	115	4.5276	0.16	9.409	9.961	15.669
32344	220	8.6614	460	18.1102	154	6.0630	145	5.7087	122	4.8031	0.16	10.197	10.787	17.244
32348	240	9.4488	500	19.6850	165	6.4961	155	6.1024	132	5.1969	0.16	10.984	11.850	18.819

*Maximum fillet which corner radius of bearing will clear.

Application Data

Bearing Tolerances — Table 10.17 thru Table 10.21 on page 318-21
 Shaft & Housing Fits — Table 10.31 on page 328

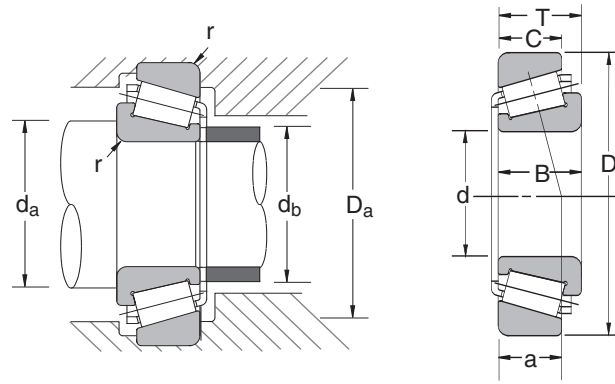

Bearing Number	Basic Load Ratings (lbs)		Limiting Speeds (1000 RPM)		Effective Load Center (inches)	Bearing Weight (Approx.)
	C_r	C_{or}	Grease	Oil	a	lbs
32303	7530	7190	8.74	11.86	0.49	0.39
HR32304J	10200	10700	8.00	11.00	0.55	0.53
HR32305J	14100	14800	6.30	8.50	0.61	0.83
HR32306J	18000	19900	5.60	7.50	0.71	1.26
HR32307J	22300	25000	5.00	6.70	0.81	1.69
HR32308J	27000	32600	4.30	6.00	0.92	2.32
HR32309J	32400	39800	3.80	5.30	0.98	3.13
HR32310J	39600	49500	3.60	4.80	1.10	4.15
HR32311J	45900	58000	3.20	4.30	1.18	5.27
HR32312J	52400	66300	3.00	4.00	1.24	6.53
HR32313J	60000	76400	2.80	3.80	1.34	7.94
HR32314J	67400	87700	2.60	3.40	1.42	9.59
HR32315J	76400	100000	2.40	3.20	1.53	11.71
HR32316J	86600	114000	2.20	3.00	1.63	14.00
HR32317J	92200	120000	2.00	2.80	1.71	16.12
HR32318J	101000	133000	2.00	2.60	1.83	18.96
HR32319J	111000	95000	1.90	2.60	1.93	22.00
HR32320J	127000	134000	1.70	2.40	2.09	28.00
HR32321J	151000	205000	1.70	2.20	2.17	32.00
HR32322J	152000	205000	1.50	2.00	2.30	38.50
HR32324J	173000	238000	1.40	1.90	2.46	48.00
32326	187000	259000	1.30	1.80	2.72	58.65
32328	221000	324000	1.20	1.60	3.01	74.75
32330	252000	382000	1.10	1.50	3.21	91.29
32332	272000	398000	1.00	1.40	3.43	106.50
32334	308000	461000	1.00	1.30	3.59	125.69
32336	342000	515000	0.95	1.30	3.80	147.29
32340	409000	645000	0.80	1.10	4.20	200.43
32344	454000	719000	0.75	1.00	4.52	251.37
32348	567000	922000	0.67	0.90	4.85	319.73

C_r = Dynamic Radial Load Rating
 C_{or} = Static Radial Load Rating

Introduction

Ball Bearings

Cylindrical Roller Bearings

Spherical Roller Bearings

Tapered Roller Bearings

Thrust Bearings

Split Pillow Blocks

Super Precision Bearings

Linear Motion

Rolling Mill Bearings

Engineering Section



Tapered Roller Bearings

32900 Metric Series

Bore Diameter 30 – 400 mm

1.1811 – 15.7480 inch

Bearing Number	Nominal Bearing Dimensions										Preferred Shoulder Diameters (in)			
	<i>d</i>		<i>D</i>		<i>T</i>		<i>B</i>		<i>C</i>		<i>r</i> *	<i>d</i> _a (min)	<i>d</i> _b (max)	<i>D</i> _a (max)
	mm	inch	mm	inch	mm	inch	mm	inch	mm	inch				
HR32906J	30	1.1811	47	1.8504	12	0.4724	12.0000	0.4724	9	0.3543	0.01	1.339	0.053	1.732
HR32907J	35	1.3780	55	2.1654	14	0.5512	14.0000	0.5512	11.5	0.4528	0.02	1.693	0.067	1.969
HR32908J	40	1.5748	62	2.4409	15	0.5906	15.0000	0.5906	12	0.4724	0.02	1.890	0.074	2.244
HR32909J	45	1.7717	68	2.6772	15	0.5906	15.0000	0.5906	12	0.4724	0.02	2.087	0.082	2.480
HR32910J	50	1.9685	72	2.8346	15	0.5906	15.0000	0.5906	12	0.4724	0.02	2.283	0.090	2.638
HR32911J	55	2.1654	80	3.1496	17	0.6693	17.0000	0.6693	14	0.5512	0.04	2.520	0.099	2.913
HR32912J	60	2.3622	85	3.3465	17	0.6693	17.0000	0.6693	14	0.5512	0.04	2.717	0.107	3.110
HR32913J	65	2.5591	90	3.5433	17	0.6693	17.0000	0.6693	14	0.5512	0.04	2.913	0.115	3.307
HR32914J	70	2.7559	100	3.9370	20	0.7874	20.0000	0.7874	16	0.6299	0.04	3.110	0.122	3.701
HR32915J	75	2.9528	105	4.1339	20	0.7874	20.0000	0.7874	16	0.6299	0.04	3.307	0.130	3.898
HR32916J	80	3.1496	110	4.3307	20	0.7874	20.0000	0.7874	16	0.6299	0.04	3.504	0.138	4.094
HR32917J	85	3.3465	120	4.7244	23	0.9055	23.0000	0.9055	18	0.7087	0.06	3.780	0.149	4.370
HR32918J	90	3.5433	125	4.9213	23	0.9055	23.0000	0.9055	18	0.7087	0.06	3.976	0.157	4.567
HR32919J	95	3.7402	130	5.1181	23	0.9055	23.0000	0.9055	18	0.7087	0.06	4.173	0.164	4.764
HR32920J	100	3.9370	140	5.5118	25	0.9843	25.0000	0.9843	20	0.7874	0.06	4.409	0.174	5.197
HR32921J	105	4.1339	145	5.7087	25	0.9843	25.0000	0.9843	20	0.7874	0.06	4.606	0.181	5.394
HR32922J	110	4.3307	150	5.9055	25	0.9843	25.0000	0.9843	20	0.7874	0.06	4.803	0.189	5.591
HR32924J	120	4.7244	165	6.4961	29	1.1417	29.0000	1.1417	23	0.9055	0.06	5.236	0.206	6.142
HR32926J	130	5.1181	180	7.0866	32	1.2598	32.0000	1.2598	25	0.9843	0.06	5.709	0.225	6.850
HR32928J	140	5.5118	190	7.4803	32	1.2598	32.0000	1.2598	25	0.9843	0.06	6.102	0.240	7.087
HR32930J	150	5.9055	210	8.2677	38	1.4961	38.0000	1.4961	30	1.1811	0.08	6.614	0.260	7.874
HR32932J	160	6.2992	220	8.6614	38	1.4961	38.0000	1.4961	30	1.1811	0.08	7.008	0.276	8.189
HR32934J	170	6.6929	230	9.0551	38	1.4961	38.0000	1.4961	30	1.1811	0.08	7.362	0.290	8.701
HR32936J	180	7.0866	250	9.8425	45	1.7717	45.0000	1.7717	34	1.3386	0.08	7.913	0.312	9.370
HR32938J	190	7.4803	260	10.2362	45	1.7717	45.0000	1.7717	34	1.3386	0.08	8.268	0.326	9.764
HR32940J	200	7.8740	280	11.0236	51	2.0079	51.0000	2.0079	39	1.5354	0.10	8.819	0.347	10.669
HR32944J	220	8.6614	300	11.8110	51	2.0079	51.0000	2.0079	39	1.5354	0.10	9.567	0.377	11.339
HR32948J	240	9.4488	320	12.5984	51	2.0079	51.0000	2.0079	39	1.5354	0.10	10.394	0.409	12.126
HR32952J	260	10.2362	360	14.1732	63.5	2.5000	63.5000	2.5000	48	1.8898	0.10	11.299	0.445	13.701
HR32956J	280	11.0236	380	14.9606	63.5	2.5000	63.5000	2.5000	48	1.8898	0.10	12.126	0.477	14.055
HR32960J	300	11.8110	420	16.5354	76	2.9921	76.0000	2.9921	57	2.2441	0.12	13.189	0.519	15.512
32964	320	12.5984	440	17.3228	76	2.9921	72.0000	2.8346	63	2.4803	0.10	13.940	0.519	16.220
HR32968J	340	13.3858	460	18.1102	76	2.9921	76.0000	2.9921	57	2.2441	0.10	14.724	0.580	17.047
HR32972J	360	14.1732	480	18.8976	76	2.9921	76.0000	2.9921	57	2.2441	0.10	15.512	0.611	17.795
32976	380	14.9606	520	20.4724	87	3.4252	82.0000	3.2283	71	2.7953	0.12	16.024	0.611	19.764
32980	400	15.7480	540	21.2598	87	3.4252	82.0000	3.2283	71	2.7953	0.12	16.811	0.611	20.551

*Maximum fillet which corner radius of bearing will clear.

Application Data

Bearing Tolerances — Table 10.17 thru Table 10.21 on page 318-21
 Shaft & Housing Fits — Table 10.31 on page 328

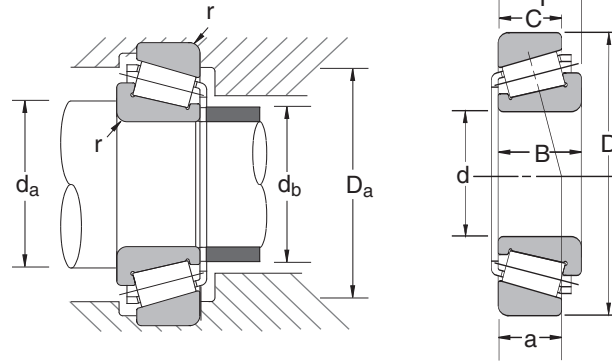

Bearing Number	Basic Load Ratings (lbs)		Limiting Speeds (1000 RPM)		Effective Load Center (inches)	Bearing Weight (Approx.)
	C_r	C_{or}	Grease	Oil	a	lbs
HR32906J	3960	5490	7.50	10.00	0.36	0.16
HR32907J	6160	8770	6.30	8.50	0.42	0.27
HR32908J	7640	10600	5.60	7.50	0.45	0.36
HR32909J	7760	11400	5.00	67.00	0.48	0.41
HR32910J	8090	12100	4.50	6.30	0.53	0.43
HR32911J	10200	16700	4.30	5.60	0.57	0.62
HR32912J	11000	19000	3.80	5.30	0.61	0.67
HR32913J	11000	19400	3.60	5.00	0.66	0.71
HR32914J	15700	25400	3.20	4.50	0.69	1.09
HR32915J	16300	27000	3.20	4.30	0.74	1.17
HR32916J	16900	28800	3.00	4.50	0.78	1.23
HR32917J	21000	35300	3.20	4.30	0.82	1.76
HR32918J	21800	37500	3.00	4.00	0.87	1.85
HR32919J	22000	38700	2.80	3.80	0.91	1.93
HR32920J	26300	46100	2.60	3.60	0.95	2.60
HR32921J	26800	47700	2.40	3.40	1.00	2.71
HR32922J	27700	50400	2.20	3.20	1.04	2.84
HR32924J	36200	63600	2.20	3.00	1.15	3.97
HR32926J	45000	82100	2.20	2.80	1.24	5.42
HR32928J	46300	87700	1.90	2.60	1.32	5.82
HR32930J	63200	117000	1.50	2.00	1.44	8.93
HR32932J	66500	128000	1.40	1.90	1.52	9.53
HR32934J	66100	126000	1.40	1.80	1.64	9.79
HR32936J	78700	154000	1.30	1.70	2.12	14.46
HR32938J	82100	161000	1.20	1.60	2.18	15.06
HR32940J	108000	210000	1.10	1.50	2.13	21.28
HR32944J	110000	223000	1.00	1.40	2.33	22.71
HR32948J	112000	234000	0.90	1.30	2.56	24.48
HR32952J	164000	326000	0.80	1.10	2.75	41.01
HR32956J	172000	355000	0.80	1.10	2.96	44.10
HR32960J	227000	472000	0.70	1.00	3.15	69.24
32964	202000	423000	0.70	0.90	3.32	70.56
HR32968J	234000	499000	0.60	0.80	3.58	75.63
HR32972J	243000	526000	0.60	0.80	3.81	79.60
32976	270000	569000	0.55	0.74	3.75	109.15
32980	279000	602000	0.52	0.70	3.97	116.20

C_r = Dynamic Radial Load Rating
 C_{or} = Static Radial Load Rating

Introduction

Ball Bearings

Cylindrical Roller Bearings

Spherical Roller Bearings

Tapered Roller Bearings

Thrust Bearings

Split Pillow Blocks

Super Precision Bearings

Linear Motion

Rolling Mill Bearings

Engineering Section



Tapered Roller Bearings

33000 Metric Series

Bore Diameter 25 – 120 mm

0.9843 – 4.7244 inch

Bearing Number	Nominal Bearing Dimensions										Preferred Shoulder Diameters (in)			
	<i>d</i>		<i>D</i>		<i>T</i>		<i>B</i>		<i>C</i>		<i>r</i> *	<i>d</i> _a (min)	<i>d</i> _b (max)	<i>D</i> _a (max)
	mm	inch	mm	inch	mm	inch	mm	inch	mm	inch				
HR33005J	25	0.9843	47	1.8504	17	0.6693	17	0.6693	14	0.5512	0.02	1.299	1.142	1.654
HR33006J	30	1.1811	55	2.1654	20	0.7874	20	0.7874	16	0.6299	0.04	1.535	1.378	1.929
HR33007J	35	1.3780	62	2.4409	21	0.8268	21	0.8268	17	0.6693	0.04	1.732	1.575	2.205
HR33008J	40	1.5748	68	2.6772	22	0.8661	22	0.8661	18	0.7087	0.04	1.929	1.772	2.441
HR33009J	45	1.7717	75	2.9528	24	0.9449	24	0.9449	19	0.7480	0.04	2.126	2.008	2.717
HR33010J	50	1.9685	80	3.1496	24	0.9449	24	0.9449	19	0.7480	0.04	2.323	2.165	2.913
HR33011J	55	2.1654	90	3.5433	27	1.0630	27	1.0630	21	0.8268	0.06	2.598	2.441	3.189
HR33012J	60	2.3622	95	3.7402	27	1.0630	27	1.0630	21	0.8268	0.06	2.795	2.598	3.386
HR33013J	65	2.5591	100	3.9370	27	1.0630	27	1.0630	21	0.8268	0.06	2.992	2.795	3.583
HR33014J	70	2.7559	110	4.3307	31	1.2205	31	1.2205	25.5	1.0039	0.06	3.189	3.071	3.976
HR33015J	75	2.9528	115	4.5276	31	1.2205	31	1.2205	25.5	1.0039	0.06	3.386	3.268	4.173
HR33016J	80	3.1496	125	4.9213	36	1.4173	36	1.4173	29.5	1.1614	0.06	3.583	3.465	4.567
HR33017J	85	3.3465	130	5.1181	36	1.4173	36	1.4173	29.5	1.1614	0.06	3.780	3.701	4.764
HR33018J	90	3.5433	140	5.5118	39	1.5354	39	1.5354	32.5	1.2795	0.06	4.016	3.898	5.157
HR33019J	95	3.7402	145	5.7087	39	1.5354	39	1.5354	32.5	1.2795	0.06	4.213	4.094	5.354
HR33020J	100	3.9370	150	5.9055	39	1.5354	39	1.5354	32.5	1.2795	0.06	4.409	4.213	5.551
HR33021J	105	4.1339	160	6.2992	43	1.6929	43	1.6929	34	1.3386	0.08	4.724	4.528	5.906
HR33022J	110	4.3307	170	6.6929	47	1.8504	47	1.8504	37	1.4567	0.08	4.921	4.764	6.299
HR33024J	120	4.7244	180	7.0866	48	1.8898	48	1.8898	38	1.4961	0.08	5.236	5.197	6.693

*Maximum fillet which corner radius of bearing will clear.

Application Data

Bearing Tolerances — Table 10.17 thru Table 10.21 on page 318-21
 Shaft & Housing Fits — Table 10.31 on page 328

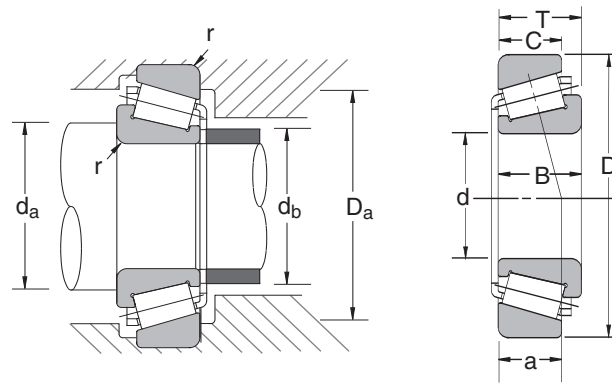

Bearing Number	Basic Load Ratings (lbs)		Limiting Speeds (1000 RPM)		Effective Load Center (inches)	Bearing Weight (Approx.)
	C_r	C_{or}	Grease	Oil	a	lbs
HR33005J	6970	8540	8.00	11.00	0.46	0.26
HR33006J	9440	12100	6.70	9.00	0.52	0.46
HR33007J	11000	14600	5.60	8.00	0.56	0.59
HR33008J	13300	18300	5.30	7.10	0.57	0.71
HR33009J	15100	21200	4.80	6.30	0.64	0.91
HR33010J	15800	23400	4.30	6.00	0.69	1.00
HR33011J	20600	31000	3.80	5.30	0.76	1.45
HR33012J	21600	33700	3.60	5.00	0.79	1.57
HR33013J	21900	35100	3.40	4.50	0.83	1.68
HR33014J	28600	45900	3.00	4.30	0.87	2.45
HR33015J	29900	49500	3.00	4.00	0.91	2.60
HR33016J	38700	63400	2.80	3.60	1.00	3.66
HR33017J	40500	68600	2.60	3.60	1.04	3.86
HR33018J	49500	80900	2.40	3.20	1.10	4.87
HR33019J	51900	87700	2.40	3.20	1.13	5.07
HR33020J	52800	91000	2.20	3.00	1.15	5.25
HR33021J	57600	97800	2.00	2.80	1.22	6.68
HR33022J	66100	116000	2.00	2.60	1.33	8.47
HR33024J	67400	121000	1.80	2.40	1.44	9.50

C_r = Dynamic Radial Load Rating
 C_{or} = Static Radial Load Rating



Tapered Roller Bearings

33100 Metric Series
Bore Diameter 45 – 110 mm
1.7717 – 4.3307 inch

Bearing Number	Nominal Bearing Dimensions										Preferred Shoulder Diameters (in)			
	<i>d</i>		<i>D</i>		<i>T</i>		<i>B</i>		<i>C</i>		<i>r</i> *	<i>d_a</i> (min)	<i>d_b</i> (max)	<i>D_a</i> (max)
	mm	inch	mm	inch	mm	inch	mm	inch	mm	inch				
HR33109J	45	1.7717	80	3.1496	26	1.0236	26	1.0236	20.5	0.8071	0.06	2.205	2.008	2.795
HR33110J	50	1.9685	85	3.3465	26	1.0236	26	1.0236	20	0.7874	0.06	2.402	2.205	2.992
HR33111J	55	2.1654	95	3.7402	30	1.1811	30	1.1811	23	0.9055	0.06	2.598	2.441	3.386
HR33112J	60	2.3622	100	3.9370	30	1.1811	30	1.1811	23	0.9055	0.06	2.795	2.677	3.583
HR33113J	65	2.5591	110	4.3307	34	1.3386	34	1.3386	26.5	1.0433	0.06	2.992	2.874	3.976
HR33114J	70	2.7559	120	4.7244	37	1.4567	37	1.4567	29	1.1417	0.06	3.228	3.110	4.370
HR33115J	75	2.9528	125	4.9213	37	1.4567	37	1.4567	29	1.1417	0.06	3.425	3.268	4.567
HR33116J	80	3.1496	130	5.1181	37	1.4567	37	1.4567	29	1.1417	0.06	3.622	3.465	4.764
HR33117J	85	3.3465	140	5.5118	41	1.6142	41	1.6142	32	1.2598	0.08	3.937	3.701	5.118
HR33118J	90	3.5433	150	5.9055	45	1.7717	45	1.7717	35	1.3780	0.08	4.134	3.937	5.512
HR33120J	100	3.9370	165	6.4961	52	2.0472	52	2.0472	40	1.5748	0.08	4.528	4.370	6.102
HR33122J	110	4.3307	180	7.0866	56	2.2047	56	2.2047	43	1.6929	0.08	4.961	4.764	6.693

*Maximum fillet which corner radius of bearing will clear.

Application Data

Bearing Tolerances — Table 10.17 thru Table 10.21 on page 318-21
Shaft & Housing Fits — Table 10.31 on page 328

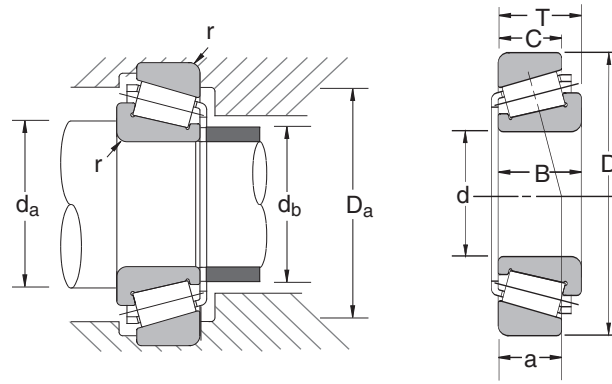

Bearing Number	Basic Load Ratings (lbs)		Limiting Speeds (1000 RPM)		Effective Load Center (inches)	Bearing Weight (Approx.)
	C_r	C_{or}	Grease	Oil	a	lbs
HR33109J	18900	25400	4.50	6.00	0.75	1.22
HR33110J	20000	28300	4.30	5.60	0.80	1.32
HR33111J	25200	35500	3.80	5.00	0.88	1.93
HR33112J	25900	37300	3.40	4.80	0.93	2.01
HR33113J	33300	49000	3.20	4.30	1.02	2.91
HR33114J	39800	58900	3.00	4.00	1.10	3.77
HR33115J	40900	61800	2.80	3.80	1.15	3.97
HR33116J	41800	65000	2.60	3.60	1.20	4.15
HR33117J	51700	82100	2.40	3.40	1.29	5.53
HR33118J	58200	91000	2.40	3.20	1.39	6.92
HR33120J	70800	116000	2.10	2.80	1.59	9.70
HR33122J	82100	137000	1.90	2.60	1.74	12.20

C_r = Dynamic Radial Load Rating
 C_{or} = Static Radial Load Rating



Tapered Roller Bearings

33200 Metric Series
Bore Diameter 25 – 100 mm
0.9843 – 3.9370 inch

Bearing Number	Nominal Bearing Dimensions										Preferred Shoulder Diameters (in)			
	<i>d</i>		<i>D</i>		<i>T</i>		<i>B</i>		<i>C</i>		<i>r</i> *	<i>d</i> _a (min)	<i>d</i> _b (max)	<i>D</i> _a (max)
	mm	inch	mm	inch	mm	inch	mm	inch	mm	inch				
HR33205J	25	0.9843	52	2.0472	22	0.8661	22	0.8661	18	0.7087	0.71	1.339	1.142	1.811
HR33206J	30	1.1811	62	2.4409	25	0.9843	25	0.9843	19.5	0.7677	0.77	1.535	1.378	2.205
HR33207J	35	1.3780	72	2.8346	28	1.1024	28	1.1024	22	0.8661	0.87	1.811	1.614	2.480
HR33208J	40	1.5748	80	3.1496	32	1.2598	32	1.2598	25	0.9843	0.98	2.008	1.811	2.795
HR33209J	45	1.7717	85	3.3465	32	1.2598	32	1.2598	25	0.9843	0.98	2.205	2.008	2.992
HR33210J	50	1.9685	90	3.5433	32	1.2598	32	1.2598	24.5	0.9646	0.96	2.402	2.205	3.189
HR33211J	55	2.1654	100	3.9370	35	1.3780	35	1.3780	27	1.0630	1.06	2.638	2.441	3.583
HR33212J	60	2.3622	110	4.3307	38	1.4961	38	1.4961	29	1.1417	1.14	2.835	2.677	3.976
HR33213J	65	2.5591	120	4.7244	41	1.6142	41	1.6142	32	1.2598	1.26	3.031	2.913	4.370
HR33214J	70	2.7559	125	4.9213	41	1.6142	41	1.6142	32	1.2598	1.26	3.228	3.071	4.567
HR33215J	75	2.9528	130	5.1181	41	1.6142	41	1.6142	31	1.2205	1.22	3.425	3.268	4.764
HR33216J	80	3.1496	140	5.5118	46	1.8110	46	1.8110	35	1.3780	1.38	3.740	3.504	5.118
HR33217J	85	3.3465	150	5.9055	49	1.9291	49	1.9291	37	1.4567	1.46	3.937	3.740	5.512
HR33220J	100	3.9370	180	7.0866	63	2.4803	63	2.4803	48	1.8898	1.89	4.646	4.524	6.378

*Maximum fillet which corner radius of bearing will clear.

Application Data

Bearing Tolerances — Table 10.17 thru Table 10.21 on page 318-21
Shaft & Housing Fits — Table 10.31 on page 328

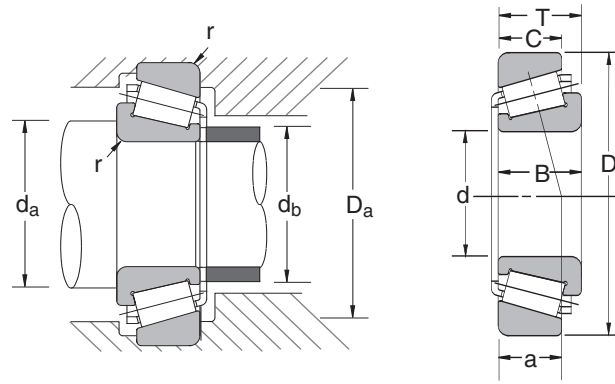

Bearing Number	Basic Load Ratings (lbs)		Limiting Speeds (1000 RPM)		Effective Load Center (inches)	Bearing Weight (Approx.)
	C_r	C_{or}	Grease	Oil	a	lbs
HR33205J	10680	12700	7.50	10.00	0.56	0.49
HR33206J	14950	17900	6.00	8.00	0.63	0.78
HR33207J	19450	24300	5.30	7.10	0.72	1.19
HR33208J	24050	30800	4.80	6.30	0.82	1.64
HR33209J	24950	33000	4.30	6.00	0.87	1.80
HR33210J	26530	37100	4.00	5.30	0.91	1.91
HR33211J	31700	43400	3.60	5.00	0.99	2.60
HR33212J	37320	51900	3.40	4.50	1.09	3.44
HR33213J	45410	63400	3.00	4.00	1.15	4.50
HR33214J	46990	67200	2.80	4.00	1.20	4.74
HR33215J	48330	70800	2.80	3.80	1.24	4.96
HR33216J	57550	86600	2.60	3.40	1.37	6.46
HR33217J	63170	93300	2.40	3.20	1.47	7.87
HR33220J	92170	143000	1.97	2.67	1.81	14.91

C_r = Dynamic Radial Load Rating
 C_{or} = Static Radial Load Rating

Introduction

Ball Bearings

Cylindrical Roller Bearings

Spherical Roller Bearings

Tapered Roller Bearings

Thrust Bearings

Split Pillow Blocks

Super Precision Bearings

Linear Motion

Rolling Mill Bearings

Engineering Section



Tapered Roller Bearings

Metric Series - Medium Angle
 30200C Series
 Bore Diameter 20 – 85 mm
 0.7874 – 3.3465 inch

Bearing Number	Nominal Bearing Dimensions										Preferred Shoulder Diameters (in)			
	<i>d</i>		<i>D</i>		<i>T</i>		<i>B</i>		<i>C</i>		<i>r</i> *	<i>d_a</i> (min)	<i>d_b</i> (max)	<i>D_a</i> (max)
	mm	inch	mm	inch	mm	inch	mm	inch	mm	inch				
HR30204C	20	0.7874	47	1.8504	15.25	0.6004	14	0.5512	12	0.4724	0.039	1.143	1.024	1.615
HR302/22C	22	0.8661	50	1.9685	15.25	0.6004	14	0.5512	12	0.4724	0.039	1.221	1.143	1.734
HR30205C	25	0.9843	52	2.0472	16.25	0.6398	15	0.5906	12	0.4724	0.039	1.340	1.261	1.812
HR302/28C	28	1.1024	58	2.2835	17.25	0.6791	16	0.6299	12	0.4724	0.039	1.458	1.340	2.049
HR30206C	30	1.1811	62	2.4409	17.25	0.6791	16	0.6299	12	0.4724	0.059	1.537	1.418	2.206
HR302/32C	32	1.2598	65	2.5591	18.25	0.7185	17	0.6693	13	0.5118	0.039	1.615	1.537	2.325
HR30207C	35	1.3780	72	2.8346	18.25	0.7185	17	0.6693	13	0.5118	0.059	1.812	1.734	2.482
HR30208C	40	1.5748	80	3.1496	19.75	0.7776	18	0.7087	14	0.5512	0.059	2.009	1.931	2.797
HR30209C	45	1.7717	85	3.3465	20.75	0.8169	19	0.7480	15	0.5906	0.059	2.206	2.087	2.992
HR30210C	50	1.9685	90	3.5433	21.75	0.8563	20	0.7874	16	0.6299	0.059	2.403	2.283	3.189
30216C	80	3.1496	140	5.5118	28.25	1.1122	26	1.0236	20	0.7874	0.118	3.743	3.622	5.118
30217C	85	3.3465	150	5.9055	30.50	1.2008	28	1.1024	22	0.8661	0.118	3.940	3.858	5.512

*Maximum fillet which corner radius of bearing will clear.

Introduction

Ball Bearings

Cylindrical Roller Bearings

Spherical Roller Bearings

Tapered Roller Bearings

Thrust Bearings

Split Pillow Blocks

Super Precision Bearings

Linear Motion

Rolling Mill Bearings

Engineering Section

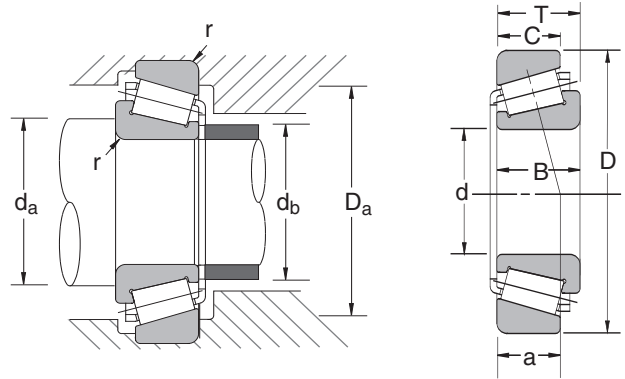

Bearing Number	Basic Load Ratings (lbs)		Limiting Speeds (1000 RPM)		Effective Load Center (inches)	Bearing Weight (Approx.)
	C_r	C_{or}	Grease	Oil	a	lbs
HR30204C	5370	5400	8.00	11.00	0.51	0.269
HR302/22C	6110	6630	7.50	10.00	0.51	0.305
HR30205C	6320	7080	6.70	9.50	0.57	0.330
HR302/28C	7640	8660	6.30	8.50	0.67	0.445
HR30206C	7980	8320	5.60	7.50	0.70	0.525
HR302/32C	10200	11800	5.60	7.50	0.67	0.590
HR30207C	10600	12300	5.00	6.70	0.77	0.715
HR30208C	24100	29000	4.50	6.00	0.85	0.935
HR30209C	14200	17600	4.30	5.60	0.84	1.050
HR30210C	15700	20900	3.80	5.30	0.95	1.190
30216C	33000	42700	2.60	3.40	1.33	3.600
30217C	38400	50800	2.40	3.20	1.43	4.500

C_r = Dynamic Radial Load Rating
 C_{or} = Static Radial Load Rating



Tapered Roller Bearings

Metric Series - Medium Angle
 30300C Series
 Bore Diameter 20 – 95 mm
 0.7874 – 3.7402 inch

Bearing Number	Nominal Bearing Dimensions										Preferred Shoulder Diameters (in)			
	<i>d</i>		<i>D</i>		<i>T</i>		<i>B</i>		<i>C</i>		<i>r</i> *	<i>d</i> _a (min)	<i>d</i> _b (max)	<i>D</i> _a (max)
	mm	inch	mm	inch	mm	inch	mm	inch	mm	inch				
HR30304C	20	0.7874	52	2.0472	16.25	0.6398	16	0.6299	12	0.4724	0.079	1.221	1.064	1.694
HR303/22C	22	0.8661	56	2.2047	17.25	0.6791	16	0.6299	13	0.5118	0.039	1.300	1.182	1.852
HR30305C	25	0.9843	62	2.4409	18.25	0.7185	17	0.6693	14	0.5512	0.059	1.418	1.379	2.088
HR303/28C	28	1.1024	68	2.6772	19.75	0.7776	18	0.7087	14	0.5512	0.059	1.537	1.497	2.325
HR30306C	30	1.1811	72	2.8346	20.75	0.8169	19	0.7480	14	0.5512	0.079	1.615	1.497	2.482
HR303/32C	32	1.2598	75	2.9528	21.75	0.8563	20	0.7874	16	0.6299	0.039	1.694	1.694	2.600
HR30307C	35	1.3780	80	3.1496	22.75	0.8957	21	0.8268	16	0.6299	0.059	1.852	1.734	2.797
HR30308C	40	1.5748	90	3.5433	25.25	0.9941	23	0.9055	18	0.7087	0.059	2.049	1.970	3.191
HR30309C	45	1.7717	100	3.9370	27.25	1.0728	25	0.9843	19	0.7480	0.059	2.246	2.246	3.583
HR30310C	50	1.9685	110	4.3307	29.25	1.1516	27	1.0630	20	0.7874	0.079	2.561	2.559	3.937
30314C	70	2.7559	150	5.9055	38.00	1.4961	35	1.3780	27	1.0630	0.138	3.467	3.425	5.433
30319C	95	3.7402	200	7.8740	49.50	1.9488	45	1.7717	36	1.4173	0.157	4.570	4.685	7.323

*Maximum fillet which corner radius of bearing will clear.

Application Data

Bearing Tolerances — Table 10.17 thru Table 10.21 on page 318-21
 Shaft & Housing Fits — Table 10.31 on page 328

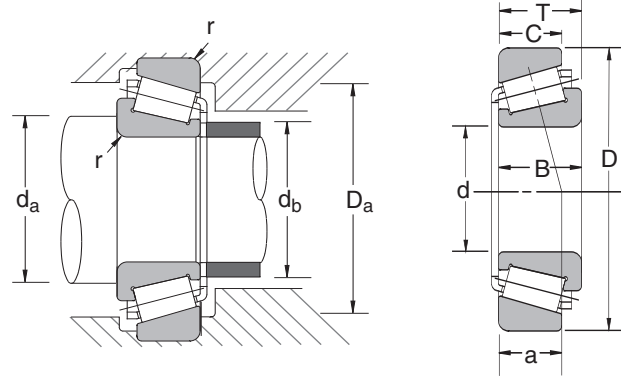

Bearing Number	Basic Load Ratings (lbs)		Limiting Speeds (1000 RPM)		Effective Load Center (inches)	Bearing Weight (Approx.) (lbs)
	C_r	C_{or}	Grease	Oil	a	lbs
HR30304C	6970	6500	8.00	11.00	0.53	0.370
HR303/22C	7760	7640	6.70	9.50	0.63	0.440
HR30305C	9440	10100	6.00	8.50	0.65	0.585
HR303/28C	11100	11400	5.60	7.50	0.69	0.740
HR30306C	12700	12500	5.30	7.10	0.73	0.860
HR303/32C	13400	15400	5.00	6.70	0.74	0.980
HR30307C	15300	15800	4.80	6.30	0.80	1.120
HR30308C	19000	21000	4.30	5.60	0.89	1.580
HR30309C	23200	26300	3.60	5.00	1.00	2.170
HR30310C	26800	31000	3.40	4.50	1.10	2.760
30314C	45200	53100	2.40	3.40	1.44	6.200
30319C	78700	96700	1.90	2.60	1.92	15.000

C_r = Dynamic Radial Load Rating
 C_{or} = Static Radial Load Rating

- Introduction
- Ball Bearings
- Cylindrical Roller Bearings
- Spherical Roller Bearings
- Tapered Roller Bearings
- Thrust Bearings
- Split Pillow Blocks
- Super Precision Bearings
- Linear Motion
- Rolling Mill Bearings
- Engineering Section



Tapered Roller Bearings

Metric Series - Medium Angle

32200C Series

Bore Diameter 20 – 60 mm

0.7874 – 2.3622 inch

Bearing Number	Nominal Bearing Dimensions										Preferred Shoulder Diameters (in)			
	<i>d</i>		<i>D</i>		<i>T</i>		<i>B</i>		<i>C</i>		<i>r</i> *	<i>d</i> _a (min)	<i>d</i> _b (max)	<i>D</i> _a (max)
	mm	inch	mm	inch	mm	inch	mm	inch	mm	inch				
HR32204C	20	0.7874	47	1.8504	19.25	0.7579	18	0.7087	15	0.5906	0.059	1.143	0.984	1.615
HR322/22C	22	0.8661	50	1.9685	19.25	0.7579	18	0.7087	15	0.5906	0.039	1.221	1.143	1.734
HR32205C	25	0.9843	52	2.0472	19.25	0.7579	18	0.7087	15	0.5906	0.039	1.340	1.182	1.812
HR322/28C	28	1.1024	58	2.2835	20.25	0.7972	19	0.7480	15	0.5906	0.059	1.458	1.300	2.049
HR32206C	30	1.1811	62	2.4409	21.25	0.8366	20	0.7874	16	0.6299	0.059	1.537	1.379	2.206
HR322/32C	32	1.2598	65	2.5591	22.25	0.8760	21	0.8268	17	0.6693	0.039	1.615	1.537	2.325
HR32207C	35	1.3780	72	2.8346	24.25	0.9547	23	0.9055	18	0.7087	0.059	1.812	1.655	3.664
HR32208C	40	1.5748	80	3.1496	24.75	0.9744	23	0.9055	18	0.7087	0.059	2.009	1.850	2.797
HR32209C	45	1.7717	85	3.3465	24.75	0.9744	23	0.9055	18	0.7087	0.059	2.206	2.047	2.992
HR32210C	50	1.9685	90	3.5433	24.75	0.9744	23	0.9055	18	0.7087	0.079	2.403	2.283	3.189
32212C	60	2.3622	110	4.3307	29.75	1.1713	28	1.1024	22	0.8661	0.098	2.837	2.677	3.976

*Maximum fillet which corner radius of bearing will clear.

Application Data

Bearing Tolerances — Table 10.17 thru Table 10.21 on page 318-21
 Shaft & Housing Fits — Table 10.31 on page 328

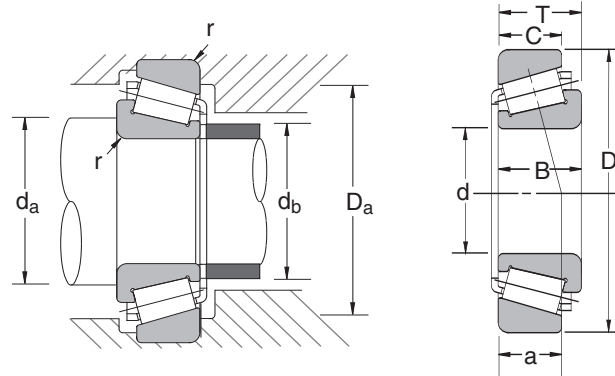

Bearing Number	Basic Load Ratings (lbs)		Limiting Speeds (1000 RPM)		Effective Load Center (inches)	Bearing Weight (Approx.)
	C_r	C_{or}	Grease	Oil	a	lbs
HR32204C	7080	7530	8.50	11.00	0.57	0.355
HR322/22C	7530	8880	7.50	10.00	0.60	0.390
HR32205C	7870	9440	7.10	9.50	0.62	0.415
HR322/28C	9440	11200	6.30	8.50	0.64	0.530
HR32206C	10800	12600	6.00	8.00	0.70	0.630
HR322/32C	11100	13500	5.60	7.50	0.80	0.730
HR32207C	13600	16100	5.00	7.10	0.81	0.950
HR32208C	16600	20300	4.80	6.30	0.85	1.200
HR32209C	17000	21500	4.30	6.00	0.96	1.300
HR32210C	17600	23200	4.00	5.40	0.98	1.380
32212C	23600	29200	3.40	4.50	1.08	2.450

C_r = Dynamic Radial Load Rating
 C_{or} = Static Radial Load Rating

Introduction

Ball Bearings

Cylindrical Roller Bearings

Spherical Roller Bearings

Tapered Roller Bearings

Thrust Bearings

Split Pillow Blocks

Super Precision Bearings

Linear Motion

Rolling Mill Bearings

Engineering Section



Tapered Roller Bearings

Metric Series - Medium Angle
 32300C Series
 Bore Diameter 20 – 75 mm
 0.7874 – 2.9528 inch

Bearing Number	Nominal Bearing Dimensions										Preferred Shoulder Diameters (in)			
	<i>d</i>		<i>D</i>		<i>T</i>		<i>B</i>		<i>C</i>		<i>r</i> *	<i>d_a</i> (min)	<i>d_b</i> (max)	<i>D_a</i> (max)
	mm	inch	mm	inch	mm	inch	mm	inch	mm	inch				
HR32304C	20	0.7874	52	2.0472	22.25	0.8760	21	0.8268	17	0.6693	0.059	1.300	1.024	1.694
HR323/28C	28	1.1024	68	2.6772	25.75	1.0138	24	0.9449	19	0.7480	0.059	1.615	1.379	2.325
HR32305C	25	0.9843	62	2.4409	25.25	0.9941	24	0.9449	19	0.7480	0.059	1.497	1.300	2.088
HR323/32C	32	1.2598	75	2.9528	29.75	1.1713	28	1.1024	22	0.8661	0.059	1.773	1.615	2.600
HR32306C	30	1.1811	72	2.8346	28.75	1.1319	27	1.0630	22	0.8661	0.079	1.694	1.418	2.482
HR32307C	35	1.3780	80	3.1496	32.75	1.2894	31	1.2205	24	0.9449	0.059	1.931	1.734	2.797
HR32308C	40	1.5748	90	3.5433	35.25	1.3878	33	1.2992	25	0.9843	0.059	2.128	1.891	3.191
HR32309C	45	1.7717	100	3.9370	38.25	1.5059	36	1.4173	28	1.1024	0.059	2.325	2.206	3.583
HR32310C	50	1.9685	110	4.3307	42.25	1.6634	40	1.5748	31	1.2205	0.079	2.677	2.323	3.937
32312C	60	2.3622	130	5.1181	48.50	1.9094	46	1.8110	35	1.3780	0.138	3.191	2.913	4.646
32314C	70	2.7559	150	5.9055	54.00	2.1260	51	2.0079	39	1.5354	0.138	3.585	3.346	5.433
32315C	75	2.9528	160	6.2992	58.00	2.2835	55	2.1654	43	1.6929	0.138	3.782	3.543	5.827

*Maximum fillet which corner radius of bearing will clear.

Application Data

Bearing Tolerances — Table 10.17 thru Table 10.21 on page 318-21
 Shaft & Housing Fits — Table 10.31 on page 328

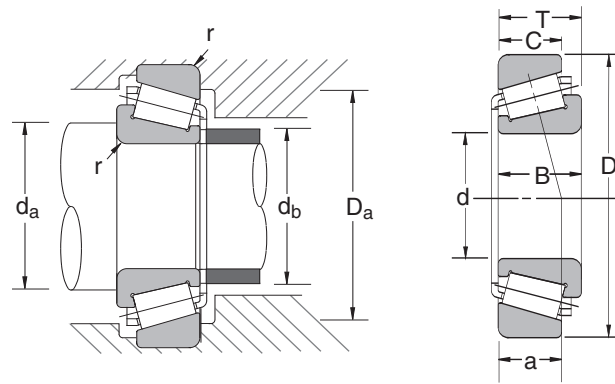

Bearing Number	Basic Load Ratings (lbs)		Limiting Speeds (1000 RPM)		Effective Load Center (inches)	Bearing Weight (Approx.)
	C_r	C_{or}	Grease	Oil	a	lbs
HR32304C	9440	10000	7.50	10.00	0.65	0.515
HR323/28C	14400	15600	5.60	7.50	0.83	0.980
HR32305C	12500	14400	6.30	8.50	0.77	0.805
HR323/32C	19000	21400	5.00	7.10	0.87	1.370
HR32306C	17100	19400	5.60	7.50	0.83	1.220
HR32307C	20000	24700	4.80	6.30	0.93	1.700
HR32308C	24100	29000	4.30	5.60	1.06	2.270
HR32309C	29900	37800	3.80	5.00	1.21	3.050
HR32310C	36900	49000	3.60	4.80	1.32	4.050
32312C	44100	56000	3.00	4.00	1.57	6.150
32314C	58900	76400	2.40	3.40	1.74	8.950
32315C	69700	94400	2.40	3.20	1.88	11.600

C_r = Dynamic Radial Load Rating
 C_{or} = Static Radial Load Rating

Introduction

Ball Bearings

Cylindrical Roller Bearings

Spherical Roller Bearings

Tapered Roller Bearings

Thrust Bearings

Split Pillow Blocks

Super Precision Bearings

Linear Motion

Rolling Mill Bearings

Engineering Section



Tapered Roller Bearings

Inch Series

Bore Diameter 12.700 – 30.213 mm

.5000 – 1.1895 inch

½ – 1 ⅞ fractional inch

Bearing Number		Basic Bearing Dimensions								
		<i>d</i> Cone		<i>D</i> Cup		<i>T</i> Assembly		<i>B</i> Cone	<i>C</i> Cup	<i>Eff. Load Center a</i>
Cone	Cup	inch	mm	inch	mm	inch	mm	inch	inch	inch
A4050	A4138	0.5000	12.700	1.3775	34.988	0.4330	10.998	0.4326	0.3437	0.33
A4059	A4138	0.5906	15.000	1.3775	34.988	0.4330	10.998	0.4326	0.3437	0.33
A6062	A6157	0.6250	15.875	1.5745	39.992	0.4730	12.014	0.4391	0.3750	0.41
11590	11520	0.6250	15.875	1.6875	42.862	0.5625	14.288	0.5625	0.3750	0.52
A6067	A6157	0.6690	16.993	1.5745	39.992	0.4730	12.014	0.4391	0.3750	0.41
LM11749	LM11710	0.6875	17.462	1.5700	39.878	0.5450	13.843	0.5750	0.4200	0.34
A6075	A6157	0.7500	19.050	1.5745	39.992	0.4730	12.014	0.4391	0.3750	0.41
LM11949	LM11910	0.7500	19.050	1.7810	45.237	0.6100	15.494	0.6550	0.4750	0.39
05075	05185	0.7500	19.050	1.8504	47.000	0.5662	14.381	0.5662	0.4375	0.41
09067	09195	0.7500	19.050	1.9380	49.225	0.7100	18.034	0.7500	0.5625	0.42
09078	09195	0.7500	19.050	1.9380	49.225	0.7813	19.845	0.8480	0.5625	0.42
09067	09196	0.7500	19.050	1.9380	49.225	0.8350	21.209	0.7500	0.6875	0.55
09074	09194	0.7500	19.050	1.9380	49.225	0.9063	23.020	0.8480	0.6875	0.55
05079	05185	0.7874	20.000	1.8504	47.000	0.5662	14.381	0.5662	0.4375	0.41
M12649	M12610	0.8437	21.430	1.9687	50.005	0.6900	17.526	0.7200	0.5500	0.44
LM12749	LM12710	0.8661	22.000	1.7810	45.237	0.6100	15.494	0.6550	0.4750	0.40
LM12749	LM12711	0.8661	22.000	1.8110	46.000	0.6100	15.494	0.6550	0.4750	0.40
07087	07196	0.8750	22.225	1.9687	50.005	0.5313	13.495	0.5614	0.3750	0.42
07098	07204	0.9835	24.981	2.0470	51.994	0.5910	15.011	0.5614	0.5000	0.48
07097	07196	0.9843	25.000	1.9687	50.005	0.5313	13.495	0.5614	0.3750	0.42
07097	07204	0.9843	25.000	2.0470	51.994	0.5910	15.011	0.5614	0.5000	0.48
07100	07196	1.0000	25.400	1.9687	50.005	0.5313	13.495	0.5614	0.3750	0.42
L44643	L44610	1.0000	25.400	1.9800	50.292	0.5600	14.224	0.5800	0.4200	0.43
15101	15245	1.0000	25.400	2.4409	62.000	0.7500	19.050	0.8125	0.5625	0.52
15100	15250X	1.0000	25.400	2.5000	63.500	0.8125	20.638	0.8125	0.6250	0.58
23100	23256	1.0000	25.400	2.5625	65.088	0.8750	22.225	0.8450	0.6250	0.79
L44649	L44610	1.0625	26.988	1.9800	50.292	0.5600	14.224	0.5800	0.4200	0.43
L45449	L45410	1.1417	29.000	1.9800	50.292	0.5600	14.224	0.5800	0.4200	0.43
15117	15245	1.1811	30.000	2.4409	62.000	0.7500	19.050	0.8125	0.5625	0.52
15117	15250	1.1811	30.000	2.5000	63.500	0.8125	20.638	0.8125	0.6250	0.58
M86649	M86610	1.1875	30.162	2.5312	64.292	0.8438	21.433	0.8438	0.6563	0.71
15118	15245	1.1895	30.213	2.4409	62.000	0.7500	19.050	0.8125	0.5625	0.52

Application Data

Bearing Tolerances — Table 10.22 thru Table 10.26 on page 322-24
 Shaft & Housing Fits — Table 10.31 on page 328

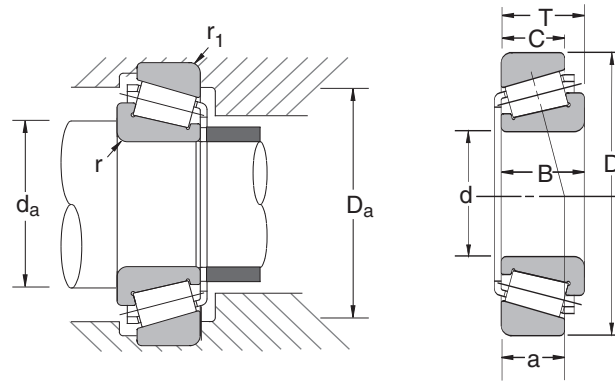

Bearing Number		Preferred Shoulder Diameters									
		Cone (r*) (inch)	Cup (r1*) (inch)	da(inch)		Da(inch)		Basic Load Ratings (lbf)		Approximate Component Weight (lbs)	
				max	min	min	max	Cr	Cor	Cone	Cup
Cone	Cup										
A4050	A4138	0.05	0.05	0.73	0.67	1.14	1.26	2640	2450	0.07	0.05
A4059	A4138	0.03	0.05	0.77	0.75	1.14	1.26	2640	2450	0.07	0.05
A6062	A6157	0.05	0.05	0.87	0.81	1.34	1.46	3360	3530	0.09	0.07
11590	11520	0.06	0.06	0.96	0.89	1.36	1.56	3890	3860	0.13	0.09
A6067	A6157	0.03	0.05	0.87	0.83	1.34	1.46	3360	3530	0.09	0.07
LM11749	LM11710	0.05	0.05	0.91	0.85	1.34	1.46	5060	5050	0.12	0.06
A6075	A6157	0.04	0.05	0.94	0.91	1.34	1.46	3360	3530	0.08	0.07
LM11949	LM11910	0.05	0.05	0.98	0.93	1.56	1.63	6410	6500	0.18	0.10
05075	05185	0.05	0.05	0.98	0.93	1.59	1.67	5360	5370	0.16	0.10
09067	09195	0.05	0.05	1.00	0.94	1.65	1.75	8000	7950	0.24	0.14
09078	09195	0.05	0.05	1.00	0.94	1.65	1.75	8000	7950	0.27	0.14
09067	09196	0.05	0.06	1.00	0.94	1.63	1.75	8000	7950	0.24	0.19
09074	09194	0.06	0.14	1.02	0.94	1.54	1.75	8000	7950	0.26	0.18
05079	05185	0.06	0.05	1.04	0.94	1.59	1.67	5360	5370	0.15	0.10
M12649	M12610	0.05	0.05	1.08	1.00	1.73	1.81	8680	9020	0.24	0.13
LM12749	LM12710	0.05	0.05	1.08	1.02	1.56	1.63	6570	7500	0.17	0.08
LM12749	LM12711	0.05	0.05	1.08	1.02	1.57	1.67	6570	7500	0.17	0.09
07087	07196	0.05	0.04	1.12	1.06	1.75	1.85	10000	12500	0.21	0.07
07098	07204	0.06	0.05	1.22	1.14	1.77	1.89	10000	12500	0.18	0.13
07097	07196	0.06	0.04	1.22	1.14	1.75	1.85	10000	12500	0.21	0.07
07097	07204	0.06	0.05	1.22	1.14	1.77	1.89	10000	12500	0.21	0.13
07100	07196	0.04	0.04	1.20	1.16	1.75	1.85	10000	12500	0.18	0.07
L44643	L44610	0.05	0.05	1.24	1.16	1.75	1.85	6210	7190	0.19	0.08
15101	15245	0.03	0.05	1.28	1.24	2.17	2.28	10400	11900	0.47	0.18
15100	15250X	0.14	0.06	1.50	1.24	2.17	2.32	10400	11900	0.47	0.25
23100	23256	0.06	0.06	1.54	1.36	2.09	2.48	10100	10700	0.46	0.31
L44649	L44610	0.14	0.05	1.48	1.22	1.75	1.85	6210	7190	0.17	0.08
L45449	L45410	0.14	0.05	1.56	1.30	1.75	1.89	6010	7670	0.17	0.08
15117	15245	0.05	0.05	1.44	1.38	2.17	2.28	10400	11900	0.40	0.18
15117	15250	0.05	0.05	1.44	1.38	2.20	2.32	10400	11900	0.40	0.25
M86649	M86610	0.06	0.06	1.61	1.50	2.13	2.40	11500	14500	0.46	0.28
15118	15245	0.14	0.05	1.63	1.40	2.17	2.28	10400	11900	0.39	0.18

*Maximum fillet which corner radius of bearing will clear.

Cr = Dynamic Radial Load Rating
Cor = Static Radial Load Rating



Tapered Roller Bearings

Inch Series (continued)

Bore Diameter 31.750 – 45.242 mm

1.2500 – 1.7812 inch

1 ¼ – 1 25/32 fractional inch

Bearing Number		Basic Bearing Dimensions								
		<i>d</i> Cone		<i>D</i> Cup		<i>T</i> Assembly		<i>B</i> Cone	<i>C</i> Cup	<i>Eff. Load Center a</i>
Cone	Cup	inch	mm	inch	mm	inch	mm	inch	inch	inch
LM67048	LM67010	1.2500	31.750	2.3280	59.131	0.6250	15.875	0.6600	0.4650	0.51
15123	15245	1.2500	31.750	2.4409	62.000	0.7150	18.161	0.7500	0.5625	0.52
15125	15245	1.2500	31.750	2.4409	62.000	0.7500	19.050	0.8125	0.5625	0.52
15126	15245	1.2500	31.750	2.4409	62.000	0.7500	19.050	0.8125	0.5625	0.52
15126	15250	1.2500	31.750	2.5000	63.500	0.8125	20.638	0.8125	0.6250	0.58
14125A	14276	1.2500	31.750	2.7170	69.012	0.7813	19.845	0.7710	0.6250	0.61
14123A	14274	1.2500	31.750	2.7170	69.012	1.0625	26.982	1.0520	0.6250	0.61
M88048	M88010	1.3125	33.338	2.6875	68.262	0.8750	22.225	0.8750	0.6875	0.76
14130	14274	1.3125	33.338	2.7170	69.012	0.7813	19.845	0.7710	0.6250	0.61
LM48548	LM48510	1.3750	34.925	2.5625	65.088	0.7100	18.034	0.7200	0.5500	0.56
14136A	14276	1.3750	34.925	2.7170	69.012	1.0625	26.982	1.0520	0.6250	0.61
14137A	14276	1.3750	34.925	2.7170	69.012	0.7813	19.845	0.7710	0.6250	0.61
14138A	14276	1.3750	34.925	2.7170	69.012	0.7813	19.845	0.7710	0.6250	0.61
25877	25821	1.3750	34.925	2.8750	73.025	0.9375	23.812	0.9688	0.7500	0.62
L68149	L68110	1.3780	35.000	2.3280	59.131	0.6250	15.875	0.6600	0.4700	0.53
L68149	L68111	1.3780	35.000	2.3622	60.000	0.6250	15.875	0.6600	0.4700	0.53
HM89449	HM89410	1.4375	36.512	3.0000	76.200	1.1563	29.370	1.1250	0.9063	0.94
JL69349	JL69310	1.4961	38.000	2.4803	63.000	0.6693	17.000	0.6693	0.5315	0.57
LM29749	LM29710	1.5000	38.100	2.5625	65.088	0.7100	18.034	0.7200	0.5500	0.54
2788	2729	1.5000	38.100	3.0000	76.200	0.9375	23.812	1.0100	0.7500	0.62
2788	2720	1.5000	38.100	3.0000	76.200	0.9375	23.812	1.0100	0.7500	0.62
18590	18520	1.6250	41.275	2.8750	73.025	0.6562	16.667	0.6875	0.5000	0.55
LM501349	LM501310	1.6250	41.275	2.8910	73.431	0.7700	19.558	0.7800	0.5800	0.64
LM501349	LM501314	1.6250	41.275	2.8910	73.431	0.8437	21.430	0.7800	0.6537	0.71
26882	26822	1.6250	41.275	3.1250	79.375	0.9375	23.812	1.0000	0.7500	0.64
342	332	1.6250	41.275	3.1496	80.000	1.1250	28.575	1.1801	0.7018	0.58
25577	25523	1.6880	42.875	3.2650	82.931	1.0625	26.988	1.0000	0.8750	0.82
25580	25520	1.7500	44.450	3.2650	82.931	0.9375	23.812	1.0000	0.7500	0.69
3578	3525	1.7500	44.450	3.4375	87.312	1.1875	30.162	1.2160	0.9375	0.79
3782	3720	1.7500	44.450	3.6718	93.264	1.1875	30.162	1.1930	0.9375	0.87
LM102949	LM102910	1.7812	45.242	2.8910	73.431	0.7700	19.558	0.7800	0.6200	0.59
LM603049	LM603011	1.7812	45.242	3.0625	77.788	0.7812	19.842	0.7812	0.5937	0.69

Application Data

Bearing Tolerances — Table 10.22 thru Table 10.26 on page 322-24
 Shaft & Housing Fits — Table 10.31 on page 328

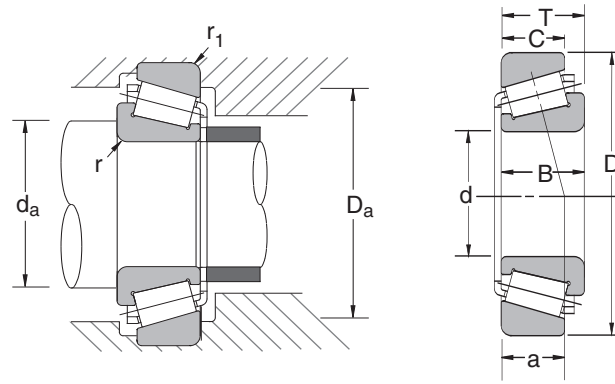

Bearing Number		Preferred Shoulder Diameters									
		Cone (r*) (inch)	Cup (r1*) (inch)	da(inch)		Da(inch)		Basic Load Ratings (lbf)		Approximate Component Weight (lbs)	
				max	min	min	max	Cr	Cor	Cone	Cup
Cone	Cup										
LM67048	LM67010	0.14	0.05	1.67	1.42	2.05	2.20	7800	9300	0.26	0.14
15123	15245	0.14	0.05	1.67	1.44	2.17	2.28	10400	11900	0.34	0.18
15125	15245	0.14	0.05	1.67	1.44	2.17	2.28	10400	11900	0.36	0.18
15126	15245	0.03	0.05	1.46	1.44	2.17	2.28	10400	11900	0.37	0.18
15126	15250	0.03	0.05	1.46	1.44	2.20	2.32	10400	11900	0.37	0.25
14125A	14276	0.14	0.05	1.73	1.48	2.36	2.48	10600	12600	0.48	0.29
14123A	14274	0.16	0.13	1.63	1.48	2.32	2.48	10600	12600	0.57	0.29
M88048	M88010	0.05	0.06	1.67	1.62	2.28	2.56	12500	15900	0.51	0.20
14130	14274	0.14	0.13	1.77	1.52	2.32	2.48	10400	12600	0.45	0.29
LM48548	LM48510	0.14	0.05	1.81	1.57	2.28	2.40	10700	13000	0.36	0.19
14136A	14276	0.03	0.05	1.63	1.57	2.36	2.48	10400	12600	0.50	0.29
14137A	14276	0.06	0.05	1.65	1.57	2.36	2.48	10400	12600	0.42	0.29
14138A	14276	0.14	0.05	1.81	1.57	2.36	2.48	10400	12600	0.42	0.29
25877	25821	0.06	0.03	1.69	1.59	2.56	2.68	16000	19300	0.67	0.36
L68149	L68110	0.14	0.05	1.79	1.54	2.05	2.20	7830	10500	0.24	0.12
L68149	L68111	0.14	0.05	1.79	1.54	2.09	2.20	7830	10500	0.24	0.14
HM89449	HM89410	0.14	0.13	2.13	1.76	2.44	2.87	17600	23900	0.83	0.55
JL69349	JL69310	0.14	0.05	1.85	1.63	2.20	2.41	8600	11700	0.29	0.13
LM29749	LM29710	0.09	0.05	1.81	1.67	2.32	2.44	9480	12400	0.34	0.17
2788	2729	0.14	0.03	1.97	1.71	2.68	2.76	16500	20500	0.68	0.41
2788	2720	0.14	0.13	1.97	1.71	2.60	2.76	16500	20500	0.68	0.41
18590	18520	0.14	0.06	2.09	1.81	2.60	2.72	10000	120800	0.45	0.19
LM501349	LM501310	0.14	0.03	2.09	1.83	2.64	2.76	12200	15100	0.48	0.24
LM501349	LM501314	0.14	0.03	2.09	1.83	2.60	2.76	12200	15100	0.48	0.28
26882	26822	0.14	0.03	2.13	1.85	2.80	2.91	16200	20900	0.75	0.41
342	332	0.14	0.05	2.09	1.81	2.87	2.95	15300	12100	0.92	0.32
25577	25523	0.14	0.09	2.17	1.93	2.83	3.03	17200	22200	0.83	0.54
25580	25520	0.14	0.03	2.24	1.97	2.91	3.03	17200	22200	0.78	0.41
3578	3525	0.14	0.13	2.24	2.01	2.95	3.19	21600	26900	1.04	0.67
3782	3720	0.14	0.03	2.28	2.05	3.23	3.46	23200	30700	1.47	0.64
LM102949	LM102910	0.14	0.03	2.20	1.97	2.68	2.76	12000	16900	0.45	0.22
LM603049	LM603011	0.14	0.03	2.24	1.97	2.80	2.91	12600	16000	0.53	0.27

*Maximum fillet which corner radius of bearing will clear.

Cr = Dynamic Radial Load Rating
Cor = Static Radial Load Rating



Tapered Roller Bearings

Inch Series (continued)

Bore Diameter 45.242 – 92.075 mm

1.7812 – 3.625 inch

1 ²⁵/₃₂ – 3 ⁵/₈ fractional inch

Bearing Number		Basic Bearing Dimensions								
		<i>d</i> Cone		<i>D</i> Cup		<i>T</i> Assembly		<i>B</i> Cone	<i>C</i> Cup	<i>Eff. Load Center a</i>
Cone	Cup	inch	mm	inch	mm	inch	mm	inch	inch	inch
LM603049	LM603012	1.7812	45.242	3.0625	77.788	0.8437	21.430	0.7812	0.6562	0.75
25590	25520	1.7960	45.618	3.2650	82.931	0.9375	23.812	1.0000	0.7500	0.69
25590	25523	1.7960	45.618	3.2650	82.931	1.0625	26.988	1.0000	0.8750	0.82
18690	18620	1.8125	46.038	3.1250	79.375	0.6875	17.462	0.6875	0.5313	0.61
368A	362A	2.0000	50.800	3.5000	88.900	0.8125	20.638	0.8750	0.6501	0.65
368A	362A	2.0000	50.800	3.5000	88.900	0.8125	20.638	0.8750	0.6501	0.65
387A	382A	2.2500	57.150	3.8125	96.838	0.8268	21.000	0.8640	0.6250	0.71
387A	382A	2.2500	57.150	3.8750	98.425	0.8268	21.000	0.8640	0.7018	0.71
3982	3920	2.5000	63.500	4.4375	112.712	1.1875	30.162	1.1830	0.9375	1.01
39585	39520	2.5000	63.500	4.4375	112.712	1.1875	30.162	1.1875	0.9375	0.93
HM212047	HM212047	2.5000	63.500	4.8125	122.238	1.5000	38.100	1.5100	1.1700	1.07
3984	3920	2.6250	66.675	4.4375	112.712	1.1875	30.162	1.1830	0.9375	1.01
39590	39520	2.6250	66.675	4.4375	112.712	1.1875	30.162	1.1875	0.9375	0.93
560	553X	2.6250	66.675	4.8125	122.238	1.5000	38.100	1.4440	1.1875	1.13
560	552A	2.6250	66.675	4.8750	123.825	1.5000	38.100	1.4400	1.1875	1.13
33287	33462	2.8750	73.025	4.6250	117.475	1.1875	30.162	1.1875	1.9375	1.08
567	563	2.8750	73.025	5.0000	127.000	1.4375	36.512	1.4240	1.1250	1.12
495	493	3.0000	76.200	5.3750	136.525	1.1875	30.162	1.1720	0.8750	1.16
575	572	3.0000	76.200	5.5115	139.992	1.4375	36.512	1.4212	1.1250	1.23
47686	47620	3.2500	82.550	5.2500	133.350	1.3125	33.338	1.3125	1.0313	1.14
580	572	3.2500	82.550	5.5115	139.992	1.4375	36.512	1.4212	1.1250	1.23
663	653	3.2500	82.550	5.7500	146.050	1.6250	41.275	1.6250	1.2500	1.31
749	742	3.3475	85.027	5.9090	150.089	1.7502	44.455	1.8375	1.4375	1.28
497	493	3.3750	85.725	5.3750	136.525	1.1875	30.162	1.1720	1.8750	1.16
665A	653	3.3750	85.725	5.7500	146.050	1.6250	41.275	1.6250	1.2500	1.31
593	592A	3.5000	88.900	6.0000	152.400	1.5625	39.688	1.4300	1.1875	1.46
598	592A	3.6250	92.075	6.0000	152.400	1.5625	39.688	1.4300	1.1875	1.46
598A	592A	3.6250	92.075	6.0000	152.400	1.5625	39.688	1.4300	1.1875	1.46

Application Data

Bearing Tolerances — Table 10.22 thru Table 10.26 on page 322-24
 Shaft & Housing Fits — Table 10.31 on page 328

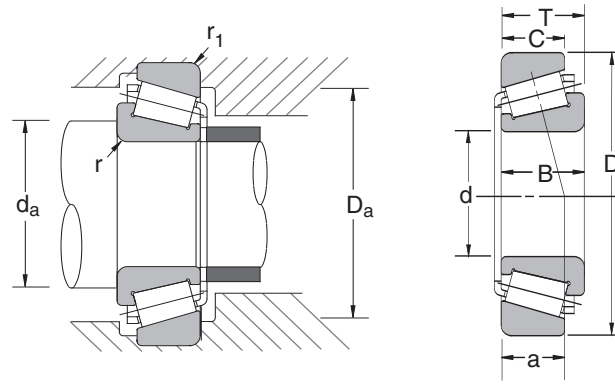

Bearing Number		Preferred Shoulder Diameters									
		Cone (r*) (inch)	Cup (r1*) (inch)	da(inch)		Da(inch)		Basic Load Ratings (lbf)		Approximate Component Weight (lbs)	
				max	min	min	max	Cr	Cor	Cone	Cup
Cone	Cup										
LM603049	LM603012	0.14	0.03	2.24	1.97	2.76	2.91	12600	16000	0.53	0.31
25590	25520	0.14	0.03	2.28	2.01	2.91	3.03	17200	22300	0.74	0.44
25590	25523	0.14	0.09	2.28	2.01	2.83	3.03	17200	22300	0.74	0.54
18690	18620	0.11	0.06	2.20	2.01	2.80	2.91	10300	12800	0.45	0.27
368A	362A	0.06	0.05	2.28	2.20	3.19	3.31	16400	19100	0.76	0.36
368A	362A	0.06	0.05	2.44	2.20	3.19	3.31	16400	19100	0.75	0.36
387A	382A	0.14	0.03	2.72	2.44	3.50	3.62	16400	20100	0.88	0.39
387A	382A	0.14	0.03	2.72	2.44	3.54	3.62	16400	20100	0.88	0.50
3982	3920	0.14	0.13	3.03	2.80	3.90	4.17	27000	39800	1.71	0.99
39585	39520	0.14	0.13	3.03	2.80	3.98	4.21	54900	91000	1.97	0.79
HM212047	HM212047	0.28	0.13	3.43	2.87	4.25	4.57	42300	55100	3.17	1.31
3984	3920	0.14	0.13	3.15	2.91	3.90	4.17	27000	39800	1.54	0.99
39590	39520	0.14	0.13	3.15	2.91	3.98	4.21	31900	45400	1.79	0.79
560	553X	0.14	0.13	3.19	2.95	4.25	4.53	41800	68600	2.51	1.51
560	552A	0.14	0.13	3.19	2.95	4.29	4.57	41800	68600	2.51	1.67
33287	33462	0.14	0.13	3.43	3.15	4.09	4.41	26800	40200	1.62	0.97
567	563	0.14	0.13	3.46	3.19	4.41	4.72	37300	52600	2.54	1.44
495	493	0.25	0.13	3.86	3.39	4.80	5.12	29200	43200	2.60	1.21
575	572	0.14	0.13	3.62	3.39	4.92	5.24	39300	58400	3.53	1.78
47686	47620	0.14	0.13	3.82	3.54	4.69	5.04	33900	53100	2.51	1.27
580	572	0.14	0.13	3.86	3.58	4.92	5.24	93300	51900	3.02	1.78
663	653	0.14	0.13	3.90	3.62	5.16	5.47	46500	66500	4.12	1.95
749	742	0.14	0.13	3.98	3.74	5.28	5.59	59600	83200	4.76	2.34
497	493	0.14	0.13	3.90	3.66	4.80	5.12	29200	43200	2.16	1.21
665A	653	0.25	0.13	4.21	3.74	5.16	5.47	46500	66500	3.77	1.95
593	592A	0.14	0.13	4.09	3.86	5.31	5.67	41100	64100	3.77	2.31
598	592A	0.14	0.13	4.21	3.98	5.31	5.67	41100	64100	3.44	2.31
598A	592A	0.25	0.13	4.45	3.98	5.31	5.67	41100	64100	3.46	2.31

*Maximum fillet which corner radius of bearing will clear.

Cr = Dynamic Radial Load Rating
Cor = Static Radial Load Rating

Introduction

Ball Bearings

Cylindrical Roller Bearings

Spherical Roller Bearings

Tapered Roller Bearings

Thrust Bearings

Split Pillow Blocks

Super Precision Bearings

Linear Motion

Rolling Mill Bearings

Engineering Section

Table of Contents Thrust Bearings

INTRODUCTION	
About NSK Thrust Bearings	138
NOMENCLATURE/INTERCHANGE	
Ball Thrust Nomenclature	139
Ball Thrust Interchange	139
Spherical Thrust Nomenclature	140
Spherical Thrust Interchange	140
APPLICATION	
Ball Thrust Applications	141
Spherical Thrust Applications	141
BEARING TABLES	
Ball Thrust (51xxx)	
Bore Size 10 – 45mm	142
Bore Size 50 – 85mm	144
Bore Size 90 – 160mm	146
Spherical Thrust (29xxx)	
Bore Size 60 – 190mm	148
Bore Size 200 – 360mm	150
Bore Size 380 – 500mm	152

Introduction

ABOUT NSK THRUST BEARINGS

- Ball Thrust Bearings
- Spherical Roller Thrust Bearings

Ball Thrust bearings are composed of washer-like bearing rings with raceway grooves for the balls. The ring attached to the shaft is called the inner ring or tight washer and the ring attached to the housing is called the outer ring or loose washer. In double direction thrust ball bearings there are three rings, with the center ring fixed to the shaft. Single direction thrust ball bearings can support axial loads in one direction only; double direction, in two. Both are available with an aligning seat and washer beneath the outer ring to compensate for shaft misalignment or deflection.

Spherical Roller Thrust bearings have a spherical raceway in the outer ring with the rollers diagonally arranged in a single row. These bearings have a very high axial load capacity and are capable of taking moderate radial loads when an axial load is imposed. Because of the configuration of their rolling elements, spherical roller thrust bearings are capable of handling misalignment and are suited for moderate speed operation.

Nomenclature — Ball Thrust Bearings

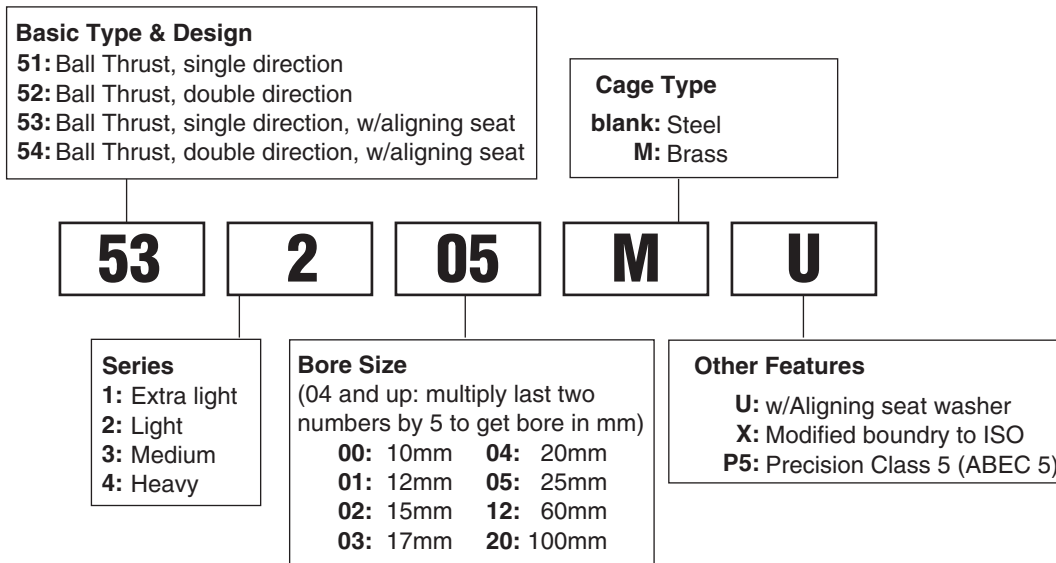

Please refer to the bearing tables for exact part number options.

Interchange — Ball Thrust Bearings

DESCRIPTION		INTERCHANGE		
		NSK	SKF	FAG
Part Number	SINGLE DIRECTION	511xx	511xx	511xx
	SINGLE DIRECTION	512xx	512xx	512xx
	SINGLE DIRECTION	513xx	513xx	513xx
	SINGLE DIRECTION	514xx	514xx	514xx
	SINGLE DIRECTION WITH ALIGNING SEAT	532xx	532xx	532xx
	SINGLE DIRECTION WITH ALIGNING SEAT	533xx	533xx	533xx
	SINGLE DIRECTION WITH ALIGNING SEAT	534xx	534xx	534xx
	DOUBLE DIRECTION	522xx	522xx	522xx
	DOUBLE DIRECTION	523xx	523xx	523xx
	DOUBLE DIRECTION	524xx	524xx	524xx
	DOUBLE DIRECTION WITH ALIGNING SEAT	542xx	542xx	542xx
	DOUBLE DIRECTION WITH ALIGNING SEAT	543xx	543xx	543xx
	DOUBLE DIRECTION WITH ALIGNING SEAT	544xx	544xx	544xx
	Suffix	STEEL CAGE	BLANK	J
BRASS CAGE		M	M	MP
BOUNDARY DIMENSIONS ADOPTED TO ISO		X	--	X
WITH SELF-ALIGNING SEAT WASHER		U	U	U
ABEC 5 PRECISION CLASS		P5	P5	P5

Nomenclature — Spherical Thrust Bearings

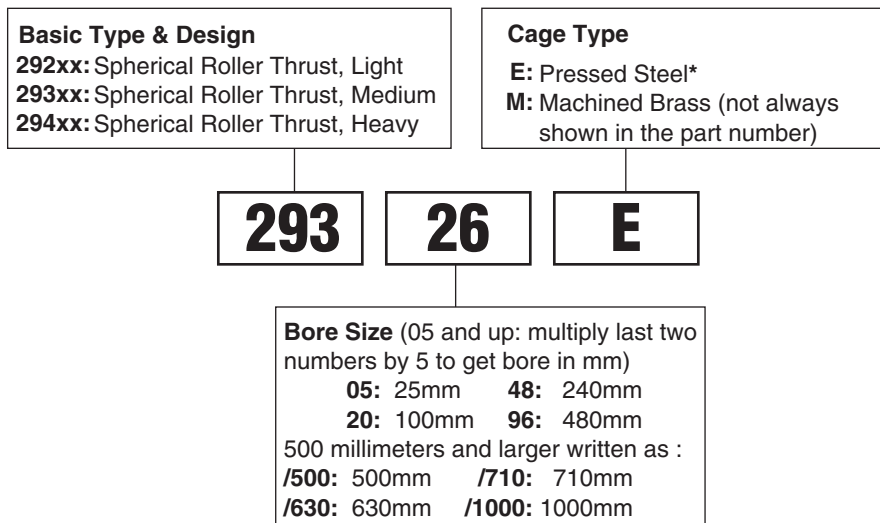

Please refer to the bearing tables for exact part number options.

Interchange — Spherical Thrust Bearings

DESCRIPTION		INTERCHANGE			
		NSK	SKF	FAG	Torrington
Part Number	LIGHT	292xx	292xx	292xx	292xx
	MEDIUM	293xx	293xx	293xx	293xx
	HEAVY	294xx	294xx	294xx	294xx
Suffix	STEEL CAGE	E	EJ	E	EJ
	BRASS CAGE	M	M	EMB	EM

*The "E" designation has replaced the "H." This is nomenclature change only, not a design change.

Thrust Bearings Applications

Listed below are popular applications for the two thrust bearing styles shown in this section. They are ball thrust bearings and spherical roller thrust bearings. Also available, but not shown, are cylindrical roller thrust bearings (TMP) and tapered roller thrust bearings (TT, TTF or V-Flat). Please consult an NSK representative for more information.

The ball thrust bearings are designed to handle thrust loads while operating at high speeds. These bearings can be ordered with an aligning seat and aligning washer if misalignment or deflection can not be avoided.

The spherical thrust bearings are designed to handle very heavy thrust loads in one direction while operating at low to moderate speeds. The design of the spherical thrust will also allow for some radial load while thrust load is imposed. The spherical shape of the outer ring raceway makes these bearings excellent for handling misalignment.

BALL THRUST BEARINGS

- Screw Jacks
- Machine Tool Spindle Tail Stock
- Vertical Openers
(Spinning and Weaving Machines)

SPHERICAL THRUST BEARINGS

- Deep Well Pumps
- Centrifugal Pumps
- Power Plant Preheater
- Coal Pulverizer
- Plastic Forming Equipment
- Crane Hook
- Industrial Gear Boxes
- Axial Piston Pumps



Ball Thrust Bearings

Single Direction, Flat Seat
Bore Diameter 10 – 45 mm
.3937 – 1.7717 inch

Bearing Number	Basic Bearing Dimensions						Preferred Shoulder Dimensions (inch)		
	<i>d</i>		<i>D</i>		<i>T</i>		<i>r</i> *	<i>da</i> min	<i>Da</i> max
	mm	inch	mm	inch	mm	inch			
51100	10	0.3937	24	0.9449	9	0.3543	0.012	0.709	0.630
51200	10	0.3937	26	1.0236	11	0.4331	0.024	0.788	0.630
51101	12	0.4724	26	1.0236	9	0.3543	0.012	0.788	0.709
51201	12	0.4724	28	1.1024	11	0.4331	0.024	0.867	0.709
51102	15	0.5906	28	1.1024	9	0.3543	0.012	0.906	0.867
51202	15	0.5906	32	1.2598	12	0.4724	0.024	0.985	0.867
51103	17	0.6693	30	1.1811	9	0.3543	0.012	0.985	0.867
51203	17	0.6693	35	1.3780	12	0.4724	0.024	1.103	0.946
51104	20	0.7874	35	1.3780	10	0.3937	0.012	1.143	1.024
51204	20	0.7874	40	1.5748	14	0.5512	0.024	1.261	1.103
51105	25	0.9843	42	1.6535	11	0.4331	0.024	1.379	1.261
51205	25	0.9843	47	1.8504	15	0.5906	0.024	1.497	1.340
51305	25	0.9843	52	2.0472	18	0.7087	0.039	1.615	1.418
51405	25	0.9843	60	2.3622	24	0.9449	0.039	1.812	1.537
51106	30	1.1811	47	1.8504	11	0.4331	0.024	1.576	1.458
51206	30	1.1811	52	2.0472	16	0.6299	0.024	1.694	1.537
51306	30	1.1811	60	2.3622	21	0.8268	0.039	1.891	1.655
51406	30	1.1811	70	2.7559	28	1.1024	0.039	2.128	1.812
51107	35	1.3780	52	2.0472	12	0.4724	0.024	1.773	1.655
51207	35	1.3780	62	2.4409	18	0.7087	0.039	2.009	1.812
51307	35	1.3780	68	2.6772	24	0.9449	0.039	2.167	1.891
51407	35	1.3780	80	3.1496	32	1.2598	0.039	2.443	2.088
51108	40	1.5748	60	2.3622	13	0.5118	0.024	2.049	1.891
51208	40	1.5748	68	2.6772	19	0.7480	0.039	2.246	2.009
51308	40	1.5748	78	3.0709	26	1.0236	0.039	2.482	2.167
51408	40	1.5748	90	3.5433	36	1.4173	0.039	2.758	2.364
51109	45	1.7717	65	2.5591	14	0.5512	0.024	2.246	2.088
51209	45	1.7717	73	2.8740	20	0.7874	0.039	2.443	2.206
51309	45	1.7717	85	3.3465	28	1.1024	0.039	2.719	2.403
51409	45	1.7717	100	3.9370	39	1.5354	0.039	3.073	2.640

*Maximum fillet which corner radius of bearing will clear.

Application Data

Bearing Tolerances — Table 10.25 thru Table 10.28 on page 324-326
Shaft & Housing Fits — Table 10.32 and Table 10.34 on page 329
Preload — page 335

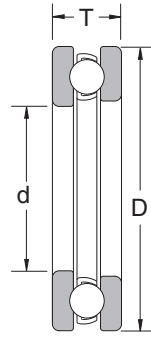
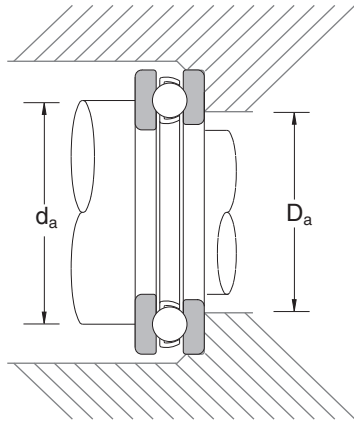

Common Options	
53xxx	: Single Direction w/Aligning Seat
53xxxU	: Single Dir. w/Aligning Seat Washer
P5 (PA5)	: ISO 5 / ABEC 5 Precision
P6 (PA3)	: ISO 6 / ABEC 3 Precision
52xxx	: Double Direction, flat seat
54xxx	: D.D. with Aligning Seat
54xxxU	: D.D. with Aligning Seat Washer

Bearing Number	Basic Load Ratings (lbs)		Limiting Speeds (1000 RPM)		Bearing Weight (Approx.)
	C_a	C_{oa}	Grease	Oil	lbs
51100	2270	3130	6.7	10.0	0.042
51200	2860	3830	6.0	9.0	0.062
51101	2330	3460	6.7	10.0	0.046
51201	2970	4270	5.6	8.5	0.068
51102	2380	3770	6.3	9.5	0.507
51202	3770	5570	5.0	7.5	0.095
51103	2570	4380	6.0	9.0	0.055
51203	3880	6120	4.8	7.5	0.110
51104	3390	5970	5.3	8.0	0.082
51204	5040	8480	4.3	6.3	0.170
51105	4430	8370	4.8	7.1	0.123
51205	6300	11300	3.8	5.6	0.245
51305	8040	13700	3.2	5.0	0.373
51405	12500	20000	2.6	4.0	0.736
51106	4630	9480	4.3	6.7	0.141
51206	6610	13100	3.4	5.3	0.302
51306	9700	17600	2.8	4.3	0.589
51406	16400	28200	2.2	3.4	1.144
51107	4960	11100	4.0	6.0	0.179
51207	8920	17500	3.0	4.5	0.463
51307	12500	23500	2.4	3.8	0.851
51407	19700	34800	2.0	3.0	1.695
51108	6100	14100	3.6	5.3	0.265
51208	10600	22000	2.8	4.3	0.595
51308	15600	30200	2.2	3.4	1.182
51408	23100	42100	1.7	2.6	2.425
51109	6300	15500	3.4	5.0	0.313
51209	10800	23500	2.6	4.0	0.683
51309	18000	36800	2.0	3.0	1.482
51409	28600	55300	1.6	2.4	3.219

C_a = Dynamic Axial Load Rating
 C_{oa} = Static Axial Load Rating

Introduction

Ball Bearings

Cylindrical Roller Bearings

Spherical Roller Bearings

Tapered Roller Bearings

Thrust Bearings

Split Pillow Blocks

Super Precision Bearings

Linear Motion

Rolling Mill Bearings

Engineering Section



Ball Thrust Bearings

Single Direction, Flat Seat (continued)

Bore Diameter 50 – 85 mm
1.9685 – 3.3465 inch

Bearing Number	Basic Bearing Dimensions						Preferred Shoulder Dimensions (inch)		
	<i>d</i>		<i>D</i>		<i>T</i>		<i>r</i> *	<i>da</i> min	<i>Da</i> max
	mm	inch	mm	inch	mm	inch			
51110	50	1.9685	70	2.7559	14	0.5512	0.024	2.443	2.285
51210	50	1.9685	78	3.0709	22	0.8661	0.039	2.640	2.403
51310	50	1.9685	95	3.7402	31	1.2205	0.039	3.034	2.679
51410	50	1.9685	110	4.3307	43	1.6929	0.059	3.388	2.916
51111	55	2.1654	78	3.0709	16	0.6299	0.024	2.719	2.522
51211	55	2.1654	90	3.5433	25	0.9843	0.039	2.994	2.719
51311	55	2.1654	105	4.1339	35	1.3780	0.039	3.349	2.955
51411	55	2.1654	120	4.7244	48	1.8898	0.059	3.704	3.191
51112	60	2.3622	85	3.3465	17	0.6693	0.039	2.955	2.758
51212	60	2.3622	95	3.7402	26	1.0236	0.039	3.191	2.916
51312	60	2.3622	110	4.3307	35	1.3780	0.039	3.546	3.152
51412	60	2.3622	130	5.1181	51	2.0079	0.059	4.019	3.467
51113	65	2.5591	90	3.5433	18	0.7087	0.039	3.152	2.955
51213	65	2.5591	100	3.9370	27	1.0630	0.039	3.388	3.113
51313	65	2.5591	115	4.5276	36	1.4173	0.039	3.743	3.349
51413	65	2.5591	140	5.5118	56	2.2047	0.079	4.334	3.743
51114	70	2.7559	95	3.7402	18	0.7087	0.039	3.349	3.152
51214	70	2.7559	105	4.1339	27	1.0630	0.039	3.585	3.310
51314	70	2.7559	125	4.9213	40	1.5748	0.039	4.058	3.625
51414	70	2.7559	150	5.9055	60	2.3622	0.079	4.649	4.019
51115	75	2.9528	100	3.9370	19	0.7480	0.039	3.546	3.349
51215	75	2.9528	110	4.3307	27	1.0630	0.039	3.782	3.507
51315	75	2.9528	135	5.3150	44	1.7323	0.059	4.373	3.901
51415	75	2.9528	160	6.2992	65	2.5591	0.079	4.925	4.334
51116	80	3.1496	105	4.1339	19	0.7480	0.039	3.743	3.546
51216	80	3.1496	115	4.5276	28	1.1024	0.039	3.979	3.704
51316	80	3.1496	140	5.5118	44	1.7323	0.059	4.570	4.098
51416	80	3.1496	170	6.6929	68	2.6772	0.079	5.240	4.610
51117	85	3.3465	110	4.3307	19	0.7480	0.039	3.940	3.743
51217	85	3.3465	125	4.9213	31	1.2205	0.039	4.295	3.979
51317	85	3.3465	150	5.9055	49	1.9291	0.059	4.886	4.373
51417 X	85	3.3465	180	7.0866	72	2.8346	0.079	5.555	4.886

*Maximum fillet which corner radius of bearing will clear.

Application Data

Bearing Tolerances — Table 10.25 thru Table 10.28 on page 324-326
 Shaft & Housing Fits — Table 10.32 and Table 10.34 on page 329
 Preload — page 335

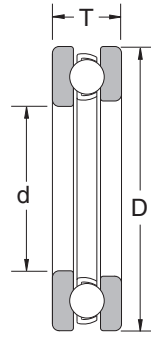
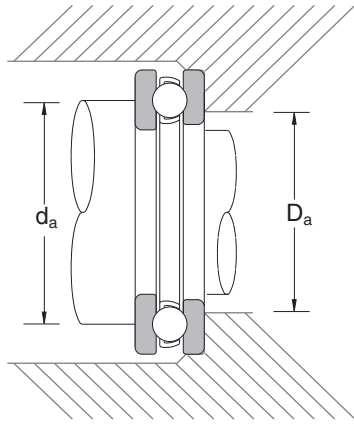

Common Options	
53xxx	: Single Direction w/Aligning Seat
53xxxU	: Single Dir. w/Aligning Seat Washer
P5 (PA5)	: ISO 5 / ABEC 5 Precision
P6 (PA3)	: ISO 6 / ABEC 3 Precision
52xxx	: Double Direction, flat seat
54xxx	: D.D. with Aligning Seat
54xxxU	: D.D. with Aligning Seat Washer

Bearing Number	Basic Load Ratings (lbs)		Limiting Speeds (1000 RPM)		Bearing Weight (Approx.)
	C_a	C_{oa}	Grease	Oil	lbs
51110	6530	17000	3.2	4.8	0.34
51210	11000	25100	2.4	3.6	0.83
51310	21900	45400	1.8	2.8	2.05
51410	33100	64800	1.4	2.2	4.28
51111	7940	20900	2.8	4.3	0.50
51211	15800	35700	2.2	3.2	1.32
51311	26000	54900	1.6	2.4	2.89
51411	40800	78300	1.3	1.9	5.69
51112	9370	25400	2.6	4.0	0.62
51212	16100	37900	2.0	3.0	1.48
51312	26700	59100	1.6	2.4	3.09
51412	45400	89300	1.2	1.8	6.97
51113	9480	26500	2.4	3.8	0.71
51213	17000	42300	1.9	2.8	1.67
51313	27600	63300	1.5	2.4	3.40
51413	52500	111000	1.1	1.7	9.04
51114	9810	28400	2.4	3.6	0.76
51214	16600	42300	1.9	2.8	1.75
51314	30900	70500	1.4	2.0	4.41
51414	56700	125000	1.0	1.5	11.13
51115	9810	29500	2.2	3.4	0.86
51215	17500	47000	1.8	2.8	1.86
51315	35700	82700	1.3	1.9	5.73
51415	57100	126000	1.0	1.4	13.56
51116	10100	31700	2.2	3.4	0.92
51216	17700	49200	1.8	2.6	2.05
51316	36800	88200	1.3	1.9	6.04
51416	61300	140000	0.9	1.3	15.90
51117	10400	33700	2.2	3.2	0.97
51217	21600	59300	1.6	2.4	2.69
51317	46500	110000	1.1	1.7	7.87
51417 X	69400	170000	0.9	1.3	18.76

C_a = Dynamic Axial Load Rating
 C_{oa} = Static Axial Load Rating

Introduction

Ball Bearings

Cylindrical Roller Bearings

Spherical Roller Bearings

Tapered Roller Bearings

Thrust Bearings

Split Pillow Blocks

Super Precision Bearings

Linear Motion

Rolling Mill Bearings

Engineering Section



Ball Thrust Bearings

Single Direction, (continued)

Bore Diameter 90 – 160 mm
3.5433 – 6.2992 inch

Bearing Number	Basic Bearing Dimensions						Preferred Shoulder Dimensions (inch)		
	<i>d</i>		<i>D</i>		<i>T</i>		<i>r</i> *	<i>da</i> min	<i>Da</i> max
	mm	inch	mm	inch	mm	inch			
51118	90	3.5433	120	4.7244	22	0.8661	0.039	4.255	4.019
51218	90	3.5433	135	5.3150	35	1.3780	0.039	4.610	4.255
51318	90	3.5433	155	6.1024	50	1.9685	0.059	5.083	4.570
51418 X	90	3.5433	190	7.4803	77	3.0315	0.079	5.871	5.161
51120	100	3.9370	135	5.3150	25	0.9843	0.039	4.767	4.492
51220	100	3.9370	150	5.9055	38	1.4961	0.039	5.122	4.728
51320	100	3.9370	170	6.6929	55	2.1654	0.059	5.595	5.043
51420 X	100	3.9370	210	8.2677	85	3.3465	0.099	6.501	5.713
51122	110	4.3307	145	5.7087	25	0.9843	0.039	5.161	4.886
51222	110	4.3307	160	6.2992	38	1.4961	0.039	5.516	5.122
51322 X	110	4.3307	190	7.4803	63	2.4803	0.079	6.225	5.595
51422 X	110	4.3307	230	9.0551	95	3.7402	0.099	7.131	6.265
51124	120	4.7244	155	6.1024	25	0.9843	0.039	5.555	5.280
51224	120	4.7244	170	6.6929	39	1.5354	0.039	5.910	5.516
51324 X	120	4.7244	210	8.2677	70	2.7559	0.079	6.816	6.186
51424 X	120	4.7244	250	9.8425	102	4.0157	0.118	7.722	6.856
51126	130	5.1181	170	6.6929	30	1.1811	0.039	6.068	5.752
51226 X	130	5.1181	190	7.4803	45	1.7717	0.059	6.540	6.068
51326 X	130	5.1181	225	8.8583	75	2.9528	0.079	7.328	6.659
51426 X	130	5.1181	270	10.6299	110	4.3307	0.118	8.353	7.407
51128 X	140	5.5118	200	7.8740	31	1.2205	0.039	6.462	6.146
51228 X	140	5.5118	240	9.4488	46	1.8110	0.059	6.934	6.462
51328 X	140	5.5118	280	11.0236	80	3.1496	0.079	7.841	7.131
51428 X	140	5.5118	160	6.2992	112	4.4094	0.118	8.747	7.801
51130 X	150	5.9055	190	7.4803	31	1.2205	0.039	6.856	6.540
51230 X	150	5.9055	215	8.4646	50	1.9685	0.059	7.447	6.934
51330 X	150	5.9055	250	9.8425	80	3.1496	0.079	8.235	7.525
51430 X	150	5.9055	300	11.8110	120	4.7244	0.118	9.377	8.353
51132 X	160	6.2992	200	7.8740	31	1.2205	0.039	7.250	6.934
51232 X	160	6.2992	225	8.8583	51	2.0079	0.059	7.841	7.329
51332 X	160	6.2992	270	10.6299	87	3.4252	0.099	8.865	8.077
51432 X	160	6.2992	320	12.5984	130	5.1181	0.158	10.008	8.904

*Maximum fillet which corner radius of bearing will clear.

Application Data

Bearing Tolerances — Table 10.25 thru Table 10.28 on page 324-326
 Shaft & Housing Fits — Table 10.32 and Table 10.34 on page 329
 Preload — page 335

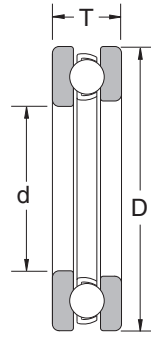
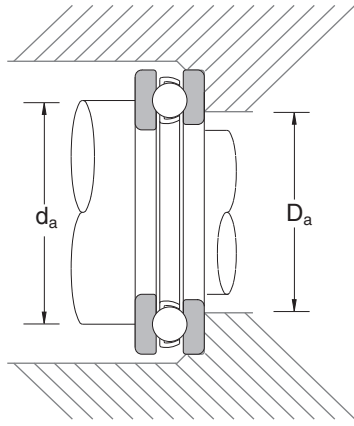

Common Options	
53xxx	: Single Direction w/Aligning Seat
53xxxU	: Single Dir. w/Aligning Seat Washer
P5 (PA5)	: ISO 5 / ABEC 5 Precision
P6 (PA3)	: ISO 6 / ABEC 3 Precision
52xxx	: Double Direction, flat seat
54xxx	: D.D. with Aligning Seat
54xxxU	: D.D. with Aligning Seat Washer

Bearing Number	Basic Load Ratings (lbs)		Limiting Speeds (1000 RPM)		Bearing Weight (Approx.)
	C_a	C_{oa}	Grease	Oil	lbs
51118	13600	42800	1.9	3.0	1.42
51218	25600	69400	1.4	2.2	3.73
51318	48300	118000	1.1	1.7	8.44
51418 X	73900	185000	8.0	1.2	22.49
51120	19300	60200	1.7	2.6	2.12
51220	30200	84900	1.3	2.0	4.96
51320	53600	134000	1.0	1.5	10.98
51420 X	83800	220000	7.1	1.1	32.63
51122	19700	64800	1.7	2.4	2.29
51222	30600	88200	1.3	1.9	5.34
51322 X	63500	170000	9.0	1.3	15.83
51422 X	92600	260000	6.3	1.0	44.09
51124	20200	69400	1.6	2.4	2.47
51224	31700	97000	1.2	1.8	5.93
51324 X	73900	209000	8.0	1.2	21.39
51424 X	108000	313000	6.0	0.9	57.76
51126	23600	79400	1.4	2.0	3.70
51226 X	41200	123000	1.1	1.6	8.71
51326 X	78300	231000	7.5	1.1	26.68
51426 X	118000	357000	5.3	0.8	71.21
51128 X	24300	84900	1.3	2.0	4.03
51228 X	41700	130000	1.0	1.5	9.48
51328 X	82700	254000	6.7	1.0	34.39
51428 X	125000	392000	5.3	0.8	76.50
51130 X	24700	90400	1.3	1.9	4.28
51230 X	53600	165000	9.5	1.4	12.15
51330 X	86000	271000	6.7	1.0	36.82
51430 X	139000	452000	4.8	0.7	95.90
51132 X	25400	95900	1.2	1.9	4.54
51232 X	56000	181000	9.0	1.4	13.32
51332 X	101000	331000	6.0	0.9	47.40
51432 X	146000	498000	4.5	0.7	116.20

C_a = Dynamic Axial Load Rating
 C_{oa} = Static Axial Load Rating

Introduction

Ball Bearings

Cylindrical Roller Bearings

Spherical Roller Bearings

Tapered Roller Bearings

Thrust Bearings

Split Pillow Blocks

Super Precision Bearings

Linear Motion

Rolling Mill Bearings

Engineering Section



Spherical Roller Thrust Bearings

Bore Diameter 60 – 190 mm
2.3622 – 7.4803 inch

Bearing Number	Nominal Bearing Dimensions								
	<i>d</i>		<i>D</i>		<i>T</i>		<i>d₁</i>	<i>D₁</i>	<i>C</i>
	mm	inch	mm	inch	mm	inch	inch	inch	inch
29412 E	60	2.3622	130	5.1181	42	1.6535	4.508	3.504	0.787
29413 E	65	2.5591	140	5.5118	45	1.7717	4.783	3.661	0.866
29414 E	70	2.7559	150	5.9055	48	1.8898	5.177	4.016	0.945
29415 E	75	2.9528	160	6.2992	51	2.0079	5.433	4.213	0.984
29416 E	80	3.1496	170	6.6929	54	2.1260	5.827	4.508	1.063
29317 E	85	3.3465	150	5.9055	39	1.5354	5.295	4.409	0.748
29417 E	85	3.3465	180	7.0866	58	2.2935	6.161	4.882	1.102
29318 E	90	3.5433	150	6.1024	39	1.5354	5.492	4.646	0.748
29418 E	90	3.5433	190	7.4803	60	2.3622	6.516	5.098	1.142
29320 E	100	3.9370	170	6.6929	42	1.6535	5.984	5.039	0.819
29420 E	100	3.9370	210	8.2677	67	2.6378	7.293	5.669	1.299
29322 E	110	4.3307	190	7.4803	48	1.8898	6.673	5.610	0.945
29422 E	110	4.3307	230	9.0551	73	2.8740	7.874	6.181	1.417
29324 E	120	4.7244	210	8.2677	54	2.1260	7.382	6.161	1.063
29424 E	120	4.7244	250	9.8425	78	3.0709	8.465	6.732	1.496
29326 E	130	5.1181	225	8.8583	58	2.2835	8.012	6.634	1.102
29426 E	130	5.1181	270	10.6299	85	3.3465	9.252	7.293	1.654
29328 E	140	5.5118	240	9.4488	60	2.3622	8.524	7.047	1.181
29428 E	140	5.5118	280	11.0236	85	3.3465	9.626	7.697	1.654
29330 E	150	5.9055	250	9.9425	60	2.3622	8.819	7.480	1.142
29430 E	150	5.9055	300	11.8110	90	3.5433	10.472	8.228	1.732
29332 E	160	6.2992	270	10.6299	67	2.6378	9.567	7.992	1.299
29432 E	160	6.2992	320	12.5984	95	3.7402	10.945	8.839	1.811
29334 E	170	6.6929	280	11.0236	67	2.6378	9.921	8.445	1.260
29434	170	6.6929	340	13.3958	103	4.0551	12.205	9.567	1.969
29336 E	180	7.0866	300	11.8110	73	2.8740	10.630	8.937	1.417
29436	180	7.0866	360	14.1732	109	4.2913	12.992	10.039	2.047
29338 E	190	7.4803	320	12.5984	78	3.0709	11.358	9.606	1.496
29438	190	7.4803	380	14.9606	115	4.5276	13.583	10.669	2.165

Application Data

Bearing Tolerances — Table 10.25 thru Table 10.28 on page 324-326
 Shaft & Housing Fits — Table 10.32 and Table 10.34 on page 329
 Preload — page 335

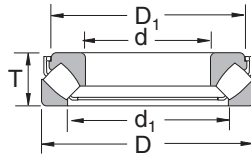
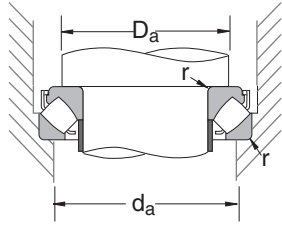

Common Options	
E*	: Stamped Steel Cage
M†	: Machined Brass Cage
†May not be shown in part number	
*The "E" designation has replaced the "H." This is a nomenclature change only, not a design change.	

Bearing Number	Preferred Shoulder Diameters (inch)			Basic Load Ratings (lbs)		Limiting Speeds (1000 RPM)	Bearing Weight (Approx.)
	r^*	D_a min	d_a min	C_a	C_{oa}	Oil	lbs
29412 E	0.059	3.543	4.252	74500	199000	2.6	5.60
29413 E	0.079	3.937	4.528	91000	247000	2.4	7.05
29414 E	0.079	4.134	4.921	102000	279000	2.2	8.60
29415 E	0.079	4.528	5.197	116000	322000	2.2	10.30
29416 E	0.079	4.724	5.512	129000	360000	2.0	12.20
29317 E	0.059	4.528	5.315	74500	234000	2.2	5.95
29417 E	0.079	5.118	5.906	142000	396000	1.9	14.40
29318 E	0.059	4.724	5.512	78500	243000	2.2	6.25
29418 E	0.079	5.315	6.181	156000	438000	1.8	16.60
29320 E	0.059	5.118	5.906	92000	288000	2.0	7.95
29420 E	0.098	5.906	6.890	189000	540000	1.6	22.70
29322 E	0.079	5.709	6.496	120000	384000	1.8	11.60
29422 E	0.098	6.496	7.480	227000	659000	1.4	29.30
29324 E	0.079	6.299	7.087	144000	472000	1.6	16.10
29424 E	0.118	7.087	8.071	262000	764000	1.4	36.50
29326 E	0.079	6.693	7.677	166000	551000	1.5	19.70
29426 E	0.118	7.677	8.858	298000	877000	1.2	46.50
29328 E	0.079	7.283	8.071	189000	632000	1.4	22.90
29428 E	0.118	8.071	9.252	310000	944000	1.2	49.00
29330 E	0.079	7.677	8.465	196000	652000	1.4	23.80
29430 E	0.118	8.661	9.843	355000	1100000	1.1	60.00
29332 E	0.098	8.768	9.252	226000	764000	1.3	31.50
29432 E	0.157	9.055	10.433	390000	1210000	1.1	70.80
29334 E	0.098	8.661	9.646	235000	787000	1.2	32.50
29434	0.157	9.646	11.220	375000	1300000	0.1	96.00
29336 E	0.098	9.252	10.236	277000	944000	1.1	42.50
29436	0.157	10.236	11.811	420000	1460000	0.9	115.00
29338 E	0.118	9.843	10.827	310000	1060000	1.0	50.50
29438	0.157	10.827	12.598	475000	1670000	0.9	132.00

*Maximum fillet which corner radius of bearing will clear.

C_a = Dynamic Axial Load Rating
 C_{oa} = Static Axial Load Rating

Introduction
 Ball Bearings
 Cylindrical Roller Bearings
 Spherical Roller Bearings
 Tapered Roller Bearings
 Thrust Bearings
 Split Pillow Blocks
 Super Precision Bearings
 Linear Motion
 Rolling Mill Bearings
 Engineering Section



Spherical Roller Thrust Bearings

(continued)

Bore Diameter 200 – 360 mm
7.8740– 14.1732 inch

Bearing Number	Nominal Bearing Dimensions								
	<i>d</i>		<i>D</i>		<i>T</i>		<i>d_I</i>	<i>D_I</i>	<i>C</i>
	mm	inch	mm	inch	mm	inch	inch	inch	inch
29240	200	7.8740	280	11.0236	48	1.8898	10.472	9.291	0.945
29340 E	200	7.8740	340	13.3858	85	3.3465	12.067	10.118	1.614
29440	200	7.8740	400	15.7480	122	4.8031	14.370	11.024	2.323
29244	220	8.6614	300	11.8110	48	1.8898	11.220	10.000	0.945
29344	220	8.6614	360	14.1732	85	3.3465	13.189	11.024	1.614
29444	220	8.6614	420	16.5354	122	4.8031	15.157	12.126	2.283
29248	240	9.4488	340	13.3858	60	2.3622	12.795	11.142	1.181
29348	240	9.4488	380	14.9606	85	3.3465	13.976	11.811	1.614
29448	240	9.4488	440	17.3228	122	4.8031	15.945	12.835	2.323
29252	260	10.2362	360	14.1732	60	2.3622	13.583	11.890	1.181
29352	260	10.2362	420	16.5354	95	3.7402	15.354	12.953	1.772
29452	260	10.2362	480	18.8976	132	5.1969	17.520	14.055	2.520
29256	280	11.0236	380	14.9606	60	2.3622	14.370	12.717	1.181
29356	280	11.0236	440	17.3228	95	3.7402	18.898	15.118	1.811
29456	280	11.0236	520	20.4724	145	5.7087	18.898	15.118	2.677
29260	300	11.8110	420	16.9540	73	2.8740	15.748	13.898	1.496
29360	300	11.8110	480	18.8976	109	4.2913	17.717	14.921	1.969
29460	300	11.8110	540	21.2598	145	5.7087	19.685	15.827	2.756
29264	320	12.5984	440	17.3228	73	2.8740	16.535	14.646	1.496
29364	320	12.5984	500	19.6850	109	4.2913	18.504	15.709	2.087
29464	320	12.5984	580	22.8346	155	6.1024	21.850	17.165	2.953
29268	340	13.3858	460	11.1102	73	2.8740	17.323	15.551	1.457
29368	340	13.3858	540	21.2598	122	4.8031	20.079	16.850	2.323
29468	340	13.3858	620	24.4094	170	6.6929	23.228	18.189	3.228
29272	360	14.1732	500	19.6850	85	3.3465	18.898	16.654	1.732
29372	360	14.1732	560	22.0472	122	4.8031	20.669	17.638	2.323
29472	360	14.1732	640	25.1969	170	6.6929	24.016	18.898	3.228

Application Data

Bearing Tolerances — Table 10.25 thru Table 10.28 on page 324-326
 Shaft & Housing Fits — Table 10.32 and Table 10.34 on page 329
 Preload — page 335

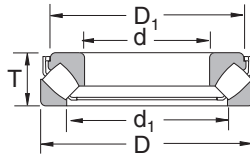
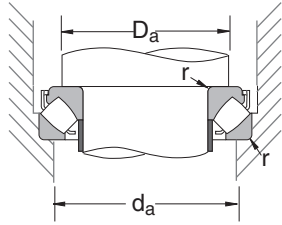

Common Options	
E*	: Stamped Steel Cage
M†	: Machined Brass Cage
†May not be shown in part number	
*The "E" designation has replaced the "H." This is a nomenclature change only, not a design change.	

Bearing Number	Preferred Shoulder Diameters (inch)			Basic Load Ratings (lbs)		Limiting Speeds (1000 RPM)	Bearing Weight (Approx.)
	r*	Da min	da min	Ca	Coa	Oil	lbs
29240	0.079	9.252	10.039	121000	519000	1.5	18.80
29340 E	0.118	10.433	11.614	355000	1230000	1.0	63.00
29440	0.157	11.417	13.189	515000	1830000	0.8	152.00
29244	0.079	10.236	10.827	126000	562000	1.40	20
29344	0.118	11.220	12.402	302000	1170000	0.95	73
29444	0.197	12.205	13.976	530000	1940000	0.80	163
29248	0.079	11.220	12.008	180000	776000	1.20	37
29348	0.118	11.811	12.992	305000	1210000	0.90	79
29448	0.197	12.992	14.764	545000	2050000	0.75	174
29252	0.079	12.008	12.795	192000	866000	1.20	40
29352	0.157	12.992	14.370	382000	1530000	0.80	107
29452	0.197	14.173	15.945	634000	2410000	0.71	231
29256	0.079	12.795	13.583	199000	922000	1.10	42
29356	0.157	13.780	15.354	411000	1720000	0.80	116
29456	0.197	15.354	17.323	764000	2950000	0.63	291
29260	0.098	13.976	14.961	261000	1160000	0.95	66
29160	0.157	14.961	16.535	492000	2050000	0.71	163
29460	0.197	16.142	18.110	787000	3080000	0.60	310
29264	0.098	14.764	15.748	268000	1230000	0.95	71.5
29364	0.157	15.748	17.323	501000	2110000	0.67	170
29464	0.236	17.126	19.488	821000	3300000	0.56	385
29268	0.098	15.551	16.535	277000	1290000	0.90	74
29368	0.157	16.929	18.504	593000	2520000	0.63	227
29468	0.236	18.307	20.866	989000	3910000	0.53	480
29272	0.118	16.535	17.913	348000	1640000	0.80	112
29372	0.157	17.717	19.488	600000	2590000	0.60	236
29472	0.236	19.094	21.654	944000	3870000	0.50	505

*Maximum fillet which corner radius of bearing will clear.

Ca = Dynamic Axial Load Rating
Coa = Static Axial Load Rating

Introduction
Ball Bearings
Cylindrical Roller Bearings
Spherical Roller Bearings
Tapered Roller Bearings
Thrust Bearings
Split Pillow Blocks
Super Precision Bearings
Linear Motion
Rolling Mill Bearings
Engineering Section



Spherical Roller Thrust Bearings

(continued)

Bore Diameter 380 – 500 mm
14.9606 – 19.6850 inch

Bearing Number	Nominal Bearing Dimensions								
	<i>d</i>		<i>D</i>		<i>H</i>		<i>d_I</i>	<i>D_I</i>	<i>C</i>
	mm	inch	mm	inch	mm	inch	inch	inch	inch
29276	380	14.9606	520	20.4724	85	3.3465	19.528	17.362	1.654
29376	380	14.9606	600	23.6220	132	5.1969	22.362	18.780	2.480
29476	380	14.9606	670	26.3780	175	6.8898	25.197	19.843	3.346
29280	400	15.7480	540	21.2598	85	3.3465	20.354	18.110	1.654
29380	400	15.7480	620	24.4094	132	5.1969	23.228	19.449	2.520
29480	400	15.7480	710	27.9528	185	7.2935	26.772	21.102	3.504
29284	420	16.5354	580	22.8346	95	3.7402	21.772	19.252	1.811
29384	420	16.5354	650	25.5906	140	5.5118	24.409	20.472	2.677
29484	420	16.5354	730	28.7402	185	7.2835	27.559	21.890	3.504
29288	440	17.3228	600	23.6220	95	3.7402	22.638	20.000	1.929
29388	440	17.3228	680	26.7717	145	5.7087	25.394	12.575	2.756
29488	440	17.3228	780	30.7087	206	8.1102	29.331	23.150	3.937
29292	460	18.1102	620	24.4094	95	3.7402	23.307	20.866	1.811
29392	460	18.1102	710	27.9528	150	5.9055	26.220	22.323	2.835
29492	460	18.1102	800	31.4961	206	8.1102	30.118	23.937	3.937
29296	480	18.8976	650	25.5906	103	4.0551	24.567	21.890	2.165
29396	480	18.8976	730	28.7402	150	5.9055	27.165	23.228	2.835
29496	480	18.8976	850	33.4646	224	8.8189	31.890	25.118	4.252
292/500	500	19.6850	670	26.3780	103	4.0551	25.394	22.598	2.165
293/500	500	19.6850	750	29.5276	150	5.9055	28.150	24.055	2.913
294/500	500	19.6850	870	34.2520	224	8.8189	32.677	26.024	4.213

Application Data

Bearing Tolerances — Table 10.25 thru Table 10.28 on page 324-326
 Shaft & Housing Fits — Table 10.32 and Table 10.34 on page 329
 Preload — page 335

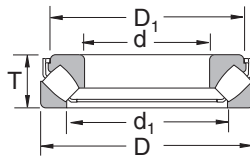
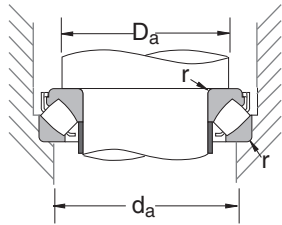

Common Options

E* : Stamped Steel Cage
M† : Machined Brass Cage

†May not be shown in part number
*The "E" designation has replaced the "H." This is a nomenclature change only, not a design change.

Bearing Number	Preferred Shoulder Diameters (inch)			Basic Load Ratings (lbs)		Limiting Speeds (1000 RPM)	Bearing Weight (Approx.)
	r^*	D_a min	d_a min	C_a	C_{oa}	Oil	lbs
29276	0.118	17.323	18.701	364000	1750000	0.75	115
29376	0.197	18.898	20.669	742000	3260000	0.56	310
29476	0.236	20.079	22.638	1080000	4380000	0.48	560
29280	0.118	19.110	19.291	369000	1800000	0.75	121
20380	0.197	19.695	21.654	731000	3260000	0.53	330
29480	0.236	21.260	24.016	1210000	4970000	0.45	675
29284	0.157	19.291	20.669	452000	2200000	0.67	159
29384	0.197	20.669	22.638	787000	3530000	0.50	375
29484	0.236	22.047	24.803	1270000	5280000	0.43	710
29288	0.157	20.079	21.457	456000	2270000	0.67	170
29388	0.197	21.654	23.622	843000	3780000	0.48	420
29488	0.315	23.425	26.378	1470000	6110000	0.40	900
29292	0.157	20.866	22.441	463000	2320000	0.63	176
29392	0.197	22.638	24.803	922000	4140000	0.45	465
29492	0.315	24.213	27.165	1520000	6430000	0.38	925
29206	0.157	21.850	23.425	533000	2720000	0.60	214
29396	0.197	23.425	25.591	933000	4270000	0.45	475
29496	0.315	25.394	28.740	1620000	6970000	0.36	1200
292/500	0.157	22.638	24.213	537000	2790000	0.60	220
293/500	0.197	24.213	26.378	978000	4590000	0.45	485
294/500	0.315	26.378	29.528	1760000	7420000	0.34	1230

*Maximum fillet which corner radius of bearing will clear.

C_a = Dynamic Axial Load Rating
 C_{oa} = Static Axial Load Rating

Introduction

Ball Bearings

Cylindrical Roller Bearings

Spherical Roller Bearings

Tapered Roller Bearings

Thrust Bearings

Split Pillow Blocks

Super Precision Bearings

Linear Motion

Rolling Mill Bearings

Engineering Section

Table of Contents Pillow Blocks

Introduction
Ball Bearings
Cylindrical Roller Bearings
Spherical Roller Bearings
Tapered Roller Bearings
Thrust Bearings
Split Pillow Blocks
Super Precision Bearings
Linear Motion
Rolling Mill Bearings
Engineering Section

INTRODUCTION	
About NSK Pillow Block Housings	155
NOMENCLATURE/INTERCHANGE	
Pillow Block Nomenclature	156
APPLICATIONS	
Pillow block applications	157
PILLOW BLOCK TABLES	
SAF 000 Series	158
SAF 200 Series	160
SAF 300 Series	162
SAF 500 Series	164
SAF 600 Series	166
SDAF 000 Series	168
SDAF 200 Series	170
SDAF 300 Series	172
SDAF 500 Series	174
SDAF 600 Series	176
Inch Adapter Sleeves	178

Introduction

ABOUT NSK PILLOW BLOCK HOUSING

- SAF Pillow Blocks
- SAFS Pillow Blocks
- SDAF Pillow Blocks

SAF Pillow Blocks are made of cast iron and accommodate self-aligning ball bearings or spherical roller bearings. SAF housings offer a choice of two or four bolt base mounting. LER triple ring seals are supplied as standard; but taconite seals and end covers are optional. SAF housings can be grease or oil lubricated.

SAFS Pillow Blocks are cast steel versions of the SAF block described above. The cast steel material offers greater strength and shock resistance for heavy-duty applications. SAFS housings offer a choice of two or four bolt base mounting. LER triple ring seals are supplied as standard; but taconite seals and end covers are optional.

SAFS housings have the same basic mounting dimensions as SAF housings but differ in some dimensions. SAFS blocks can be grease or oil lubricated.

SDAF Pillow Blocks are designed for applications where heavy thrust loads and shock require a housing of exceptionally sturdy construction. The four bolt cap and four bolt base of the heavy-duty SDAF are more than adequate to resist shock and heavy loading in any direction. The caps of these housings are supplied with tapped holes for lifting eyes. Triple ring seals are standard; but optional taconite seals and end covers are available. SDAF housings can be grease or oil lubricated.

Nomenclature — Pillow Blocks

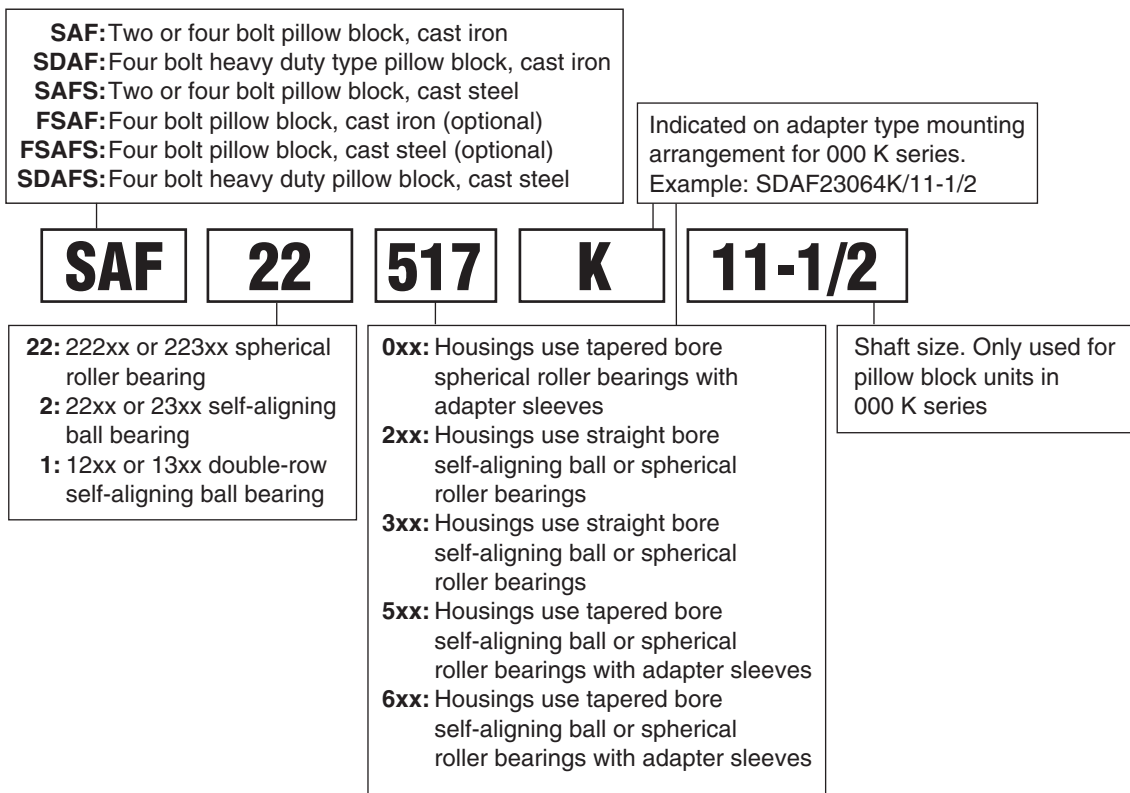

Please refer to the bearing tables for exact part number options.

- Introduction
- Ball Bearings
- Cylindrical Roller Bearings
- Spherical Roller Bearings
- Tapered Roller Bearings
- Thrust Bearings
- Split Pillow Blocks
- Super Precision Bearings
- Linear Motion
- Rolling Mill Bearings
- Engineering Section

Pillow Block Applications

ABOUT NSK PILLOW BLOCKS

NSK Pillow Blocks are designed for exceptional performance in a wide range of applications. The pillow blocks are manufactured in a wide variety of sizes out of heavy-duty cast iron. They are also available in ductile and cast steel as an option. NSK pillow blocks are tremendous at keeping water and contaminants away from the bearing while keeping lubrication inside the housing. The housing comes standard with a triple-ring labyrinth seal; but for applications where contamination is a greater concern, taconite seals are available.

NSK Pillow Blocks are completely interchangeable with other manufacturers units.

- General Industry:
 - Conveyors
 - Roller Tables
 - Fans and Blowers
- Steel Mills:
 - Runout Tables
 - Strip Processing Lines
- Processing Industry:
 - Crushers
 - Hammer Mills
 - Ball and Rod Mills
 - Decanters
 - Kilns
- Paper Making Equipment:
 - Dryer Cans
 - Jack Ladders
 - Chip Conveyers
 - Pumps
 - Pulpers
 - Breast Rolls
 - Press Rolls

Pillow Block

SAF 000K Series

Housing No.	A	B	P	G	E		E1	H	K Static Oil Level	L	Bolts (No. Req'd)	Wt.
	In.	In.	In.	In.	Max In.	Min In.	In.	In.	In.	In.	In.	lbs.*
SAF 024K/4-3/16	4-1/2	15-1/4	4-3/8	1-3/4	13-1/8	11-5/8	2-3/8	8-3/4	1-3/4	6	(4)--3/4	44
SAF 026K/4-7/16	4-15/16	16-1/2	4-3/4	2	14-1/2	12-5/8	2-3/4	9-5/8	1-7/8	6-1/2	(4)--3/4	54
SAF 028K/4-15/16	5-1/4	16-1/2	4-3/4	2-1/8	14-1/2	13-1/4	2-3/4	10-1/4	1-15/16	7-3/8	(4)--3/4	66
SAF 030K/5-3/16	6	18-3/8	5-1/8	2-3/8	16	14-5/8	3-1/4	11-9/16	2-7/16	8	(4)--7/8	96
SAF 032K/5-7/16	6	18-3/8	5-1/8	2-3/8	16	14-5/8	3-1/4	11-9/16	2-7/16	8	(4)--7/8	97
SAF 034K/5-15/16	6	20-1/8	5-7/8	2-3/8	17-1/8	16	3-3/8	11-3/4	2-1/8	7-5/8	(4)--1	120
SAF 036K/6-7/16	6-11/16	22	6-1/4	2-5/8	19-1/4	17-3/8	3-3/4	13-1/2	2-3/16	8-3/4	(4)--1	170
SAF 038K/6-15/16	6-11/16	22	6-1/4	2-5/8	19-1/4	17-3/8	3-3/4	13-1/2	2-3/16	8-3/4	(4)--1	162
SAF 040K/7-3/16	7-1/16	24-3/4	6-3/4	2-3/4	21-5/8	19-3/8	4-1/4	14-3/8	2-5/16	9-5/8	(4)--1	192
SAF 044K/7-15/16	7-7/8	28	7-1/2	3-1/8	24-3/8	21-5/8	4-1/2	15-7/8	2-5/8	10-5/8	(4)--1-1/4	300
SAF 048K/8-7/16	8-1/4	29-1/2	8	3-3/8	25	22-1/2	5	16-1/2	2-7/32	11-1/4	(4)--1-1/4	270
SAF 048K/8-1/2	8-1/4	29-1/2	8	3-3/8	25	22-1/2	5	16-1/2	2-7/32	11-1/4	(4)--1-1/4	270
SAF 048K/8-15/16	8-1/4	29-1/2	8	3-3/8	25	22-1/2	5	16-1/2	2-7/32	11-1/4	(4)--1-1/4	270
SAF 048K/9	8-1/4	29-1/2	8	3-3/8	25	22-1/2	5	16-1/2	2-7/32	11-1/4	(4)--1-1/4	270
SAF 052K/9-7/16	9-1/2	32-3/4	8-3/4	3-3/4	27-7/8	24-3/4	5-1/4	18-5/8	2-3/4	12	(4)--1-1/2	445
SAF 052K/9-1/2	9-1/2	32-3/4	8-3/4	3-3/4	27-7/8	24-3/4	5-1/4	18-5/8	2-3/4	12	(4)--1-1/2	445
SAF 056K/9-15/16	9-7/8	34-1/4	9	4	29-1/2	26-1/4	5-1/2	20-3/16	2-7/8	12-1/4	(4)--1-1/2	500
SAF 056K/10	9-7/8	34-1/4	9	4	29-1/2	26-1/4	5-1/2	20-3/16	2-7/8	12-1/4	(4)--1-1/2	500
SAF 056K/10-7/16	9-7/8	34-1/4	9	4	29-1/2	26-1/4	5-1/2	20-3/16	2-7/8	12-1/4	(4)--1-1/2	500
SAF 056K/10-1/2	9-7/8	34-1/4	9	4	29-1/2	26-1/4	5-1/2	20-3/16	2-7/8	12-1/4	(4)--1-1/2	500

*Weights are approximate

Application Data

Spherical Roller Bearings – page 78

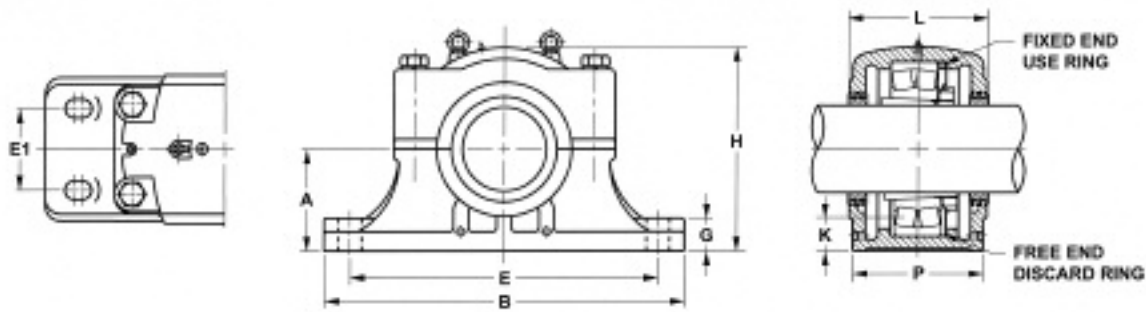

Shaft Diameter S-1 in.	Complete Unit Number	Housing Only ^(a)	Bearing Number	Adapter Locknut and Lockwasher or Lockplate	Labrynth Seals (2 required)	Fixing Ring ^(b) (1 required)	End ^(c) Cover
4-3/16	SAF 23024K/4-3/16	SAF 024K/4-3/16	23024 K	SNW 3024 X 4-3/16	LER 113	FR180X10	EPR 14
4-7/16	SAF 23026K/4-7/16	SAF 026K/4-7/16	23026 K	SNW 3026 X 4-7/16	LER 117	FR200X10	EPR 15
4-15/16	SAF 23028K/4-15/16	SAF 028K/4-15/16	23028 K	SNW 3028 X 4-15/16	LER 122	SR-0-20	EPR 27
5-3/16	SAF 23030K/5-3/16	SAF 030K/5-3/16	23030 K	SNW 3030 X 5-3/16	LER 125	SR-0-21	EPR 16
5-7/16	SAF 23032K/5-7/16	SAF 032K/5-7/16	23032 K	SNW 3032 X 5-7/16	LER 130	FR240X10	EPR 16
5-15/16	SAF 23034K/5-15/16	SAF 034K/5-15/16	23034 K	SNW 3034 X 5-15/16	LER 140	FR260X10	EPR 18
6-7/16	SAF 23036K/6-7/16	SAF 036K/6-7/16	23036 K	SNW 3036 X 6-7/16	LER 148	FR280X10	EPR 19
6-15/16	SAF 23038K/6-15/16	SAF 038K/6-15/16	23038 K	SNW 3038 X 6-15/16	LER 155	FR290X10	EPR 20
7-3/16	SAF 23040K/7-3/16	SAF 040K/7-3/16	23040 K	SNW 3040 X 7-3/16	LER 159	FR310X10	EPR 21
7-15/16	SAF 23044K/7-15/16	SAF 044K/7-15/16	23044 K	SNW 3044 X 7-15/16	LER 167	FR340X10	EPR 23
8-7/16	SAF 23048K/8-7/16	SAF 048K/8-7/16	23048 K	SNP 3048 X 8-7/16	LER 550	A 8897	---
8-1/2	SAF 23048K/8-1/2	SAF 048K/8-1/2	23048 K	SNP 3048 X 8-1/2	LER 551	A 8897	---
8-15/16	SAF 23048K/8-15/16	SAF 048K/8-15/16	23048 K	SNP 3048 X 8-15/16	LER 552	A 8897	---
9	SAF 23048K/9	SAF 048K/9	23048 K	SNP 3048 X 9	LER 513	A 8897	---
9-7/16	SAF 23052K/9-7/16	SAF 052K/9-7/16	23052 K	SNP 3052 X 9-7/16	LER 553	A 8898	---
9-1/2	SAF 23052K/9-1/2	SAF 052K/9-1/2	23052 K	SNP 3052 X 9-1/2	LER 178	A 8898	---
9-15/16	SAF 23056K/9-15/16	SAF 056K/9-15/16	23056 K	SNP 3056 X 9-15/16	ER 751	A 8819	---
10	SAF 23056K/10	SAF 056K/10	23056 K	SNP 3056 X 10	ER 705	A 8819	---
10-7/16	SAF 23056K/10-7/16	SAF 056K/10-7/16	23056 K	SNP 3056 X 10-7/16	ER 745	A 8819	---
10-1/2	SAF 23056K/10-1/2	SAF 056K/10-1/2	23056 K	SNP 3056 X 10-1/2	ER 710	A 8819	---

Note: Housings available in cast iron (SAF), Ductile (SAFD) or cast steel (SAFS).
Taconite (TER) and LOR seals with O-rings are also available

- (a) "Housing Only" includes - cap, base, cap bolts, labyrinth seals and fixing rings
- (b) Fixing Ring is used for fixed block only; do not use for float mounting
- (c) End Cover is optional

Pillow Block

SAF 200 Series

Housing No.	A	B	P	G	E		E1	H	L	Bolts (No. Req'd)	Wt.	D	F	d1	d2
	In.	In.	In.	In.	Max In.	Min In.	In.	In.	In.	In.	lbs.*	mm	mm	In.	In.
SAF 216	3-1/2	13	3-1/2	1-1/4	11	9-5/8		6-15/16	5-3/8	(2)-3/4	22.9	140	43	3-5/8	3
FSAF 216	3-1/2	13	3-1/2	1-1/4	11	9-5/8	2-1/8	6-15/16	5-3/8	(4)-5/8	22.9	140	43	3-5/8	3
SAF 217	3-3/4	13	3-1/2	1-1/4	11	9-7/8		7-3/8	5-3/8	(2)-3/4	28.6	150	46	3-15/16	3-3/16
FSAF 217	3-3/4	13	3-1/2	1-1/4	11	9-7/8	2-1/8	7-3/8	5-3/8	(4)-5/8	28.6	150	46	3-15/16	3-3/16
SAF 218	4	13-3/4	3-7/8	1-5/16	11-5/8	10-3/8		7-3/4	5-3/4	(2)-3/4	34.5	160	50	4-1/8	3-3/8
FSAF 218	4	13-3/4	3-7/8	1-5/16	11-5/8	10-3/8	2-1/8	7-3/4	5-3/4	(4)-5/8	34.5	160	50	4-1/8	3-3/8
SAF 220	4-1/2	15-1/4	4-3/8	1-3/4	13-1/8	11-5/8		8-3/4	6	(2)-7/8	50.7	180	56	4-1/2	3-13/16
FSAF 220	4-1/2	15-1/4	4-3/8	1-3/4	13-1/8	11-5/8	2-3/8	8-3/4	6	(4)-3/4	50.7	180	56	4-1/2	3-13/16
SAF 222	4-15/16	16-1/2	4-3/4	2	14-1/2	12-5/8	2-3/4	9-5/8	6-1/2	(4)-3/4	64.8	200	63	4-7/8	4-3/16
SAF 224	5-1/4	16-1/2	4-3/4	2-1/8	14-1/2	13-1/4	2-3/4	10-1/4	7-3/8	(4)-3/4	68.3	215	68	5-5/16	4-9/16
SAF 226	6	18-3/8	5-1/8	2-3/8	16	14-5/8	3-1/4	11-1/2	8	(4)-7/8	103.1	230	74	5-7/8	4-15/16
SAF 228	6	20-1/8	5-7/8	2-3/8	17-1/8	16	3-3/8	11-3/4	7-5/8	(4)-1	113.1	250	78	6-1/4	5-5/16
SAF 230	6-5/16	21-1/4	6-1/4	2-1/2	18-1/4	17	3-3/4	12-1/2	8-3/8	(4)-1	146.7	270	83	6-5/8	5-3/4
SAF 232	6-11/16	22	6-1/4	2-5/8	19-1/4	17-3/8	3-3/4	13-5/16	8-3/4	(4)-1	169.7	290	90	7	6-1/16
SAF 234	7-1/16	24-3/4	6-3/4	2-3/4	21-5/8	19-3/8	4-1/4	14-3/16	9-5/8	(4)-1	179.3	310	96	7-7/16	6-7/16
SAF 236	7-1/2	26-3/4	7-1/8	3	23-5/8	20-7/8	4-5/8	14-7/8	10	(4)-1	212.1	320	96	7-13/16	6-7/8
SAF 238	7-7/8	28	7-1/2	3-1/8	24-3/8	21-5/8	4-1/2	15-11/16	10-3/4	(4)-1 1/4	284.8	340	102	8-3/8	7-1/4
SAF 240	8-1/4	29-1/2	8	3-3/8	25	22-1/2	5	16-1/2	11-1/4	(4)-1 1/4	342.3	360	108	8-3/4	7-5/8
SAF 244	9-1/2	32-3/4	8-3/4	3-3/4	27-7/8	24-3/4	5-1/4	18-5/8	12	(4)-1 1/2	425.5	400	118	9-9/16	8-5/16

*Weights are approximate

Application Data

Spherical Roller Bearings – page 70

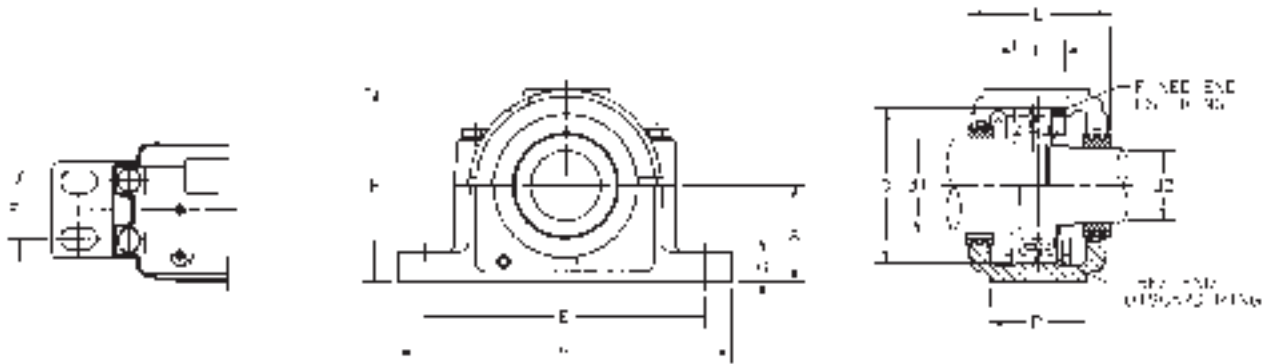

Shaft		Complete Unit Number	Housing Only ^(a)	Bearing Number	Locknut	Lockwasher	Labrynth Seals		Fixing Ring ^(b)		End Cover ^(c)
D1	D2						D1	D2	Size	Qty.	
3-5/8	3	SAF 1216	SAF 216	1216	AN 16	W 16	LER 82	LER 54	FR140X8.5	2	EPR 09
		SAF 2216	FSAF 216	2216					FR140X10	1	
		SAF 22216		22216					FR140X10	1	
3-15/16	3-3/16	SAF 1217	SAF 217	1217	AN 17	W 17	LER 89	LER 63	FR150X9	2	EPR 09
		SAF 2217	FSAF 217	2217					FR150X10	1	
		SAF 22217		22217					FR150X10	1	
4-1/8	3-3/8	SAF 1218	SAF 218	1218	AN 18	W 18	LER 112	LER 191	FR 160X10	2	EPR 11
		SAF 2218	FSAF 218	2218					FR 160X10	1	
		SAF 22218		22218					FR 160X10	1	
4-1/2	3-13/16	SAF 1220	SAF 220	1220	AN 20	W 20	LER 118	LER 106	FR180X11	2	EPR 12
		SAF 2220	FSAF 220	2220					FR180X10	1	
		SAF 22220		22220					FR180X10	1	
4-7/8	4-3/16	SAF 1222	SAF 222	1222	AN 22	W 22	LER 121	LER 113	FR200X12.5	2	EPR 14
		SAF 2222		2222					FR200X10	1	
		SAF 22222		22222					FR200X10	1	
5-5/16	4-9/16	SAF 22224	SAF 224	22224	AN 24	W 24	LER 127	LER 119	FR215X10	1	EPR 15
5-7/8	4-15/16	SAF 22226	SAF 226	22226	AN 26	W 26	LER 136	LER 122	FR230X10	1	EPR 27
6-1/4	5-15/16	SAF 22228	SAF 228	22228	AN 28	W 28	LER 144	LER 127	FR250X10	1	EPR 16
6-5/8	5-3/4	SAF 22230	SAF 230	22230	AN 30	W 30	LER 151	LER 134	FR270X10	1	EPR 17
7	6-1/16	SAF 22232	SAF 232	22232	AN 32	W 32	LER 156	LER 142	FR290X10	1	EPR 18
7-7/16	6-7/16	SAF 22234	SAF 234	22234	AN 34	W 34	LER 161	LER 148	FR310X10	1	EPR 19
7-13/16	6-7/8	SAF 22236	SAF 236	22236	AN 36	W 36	LER 165	LER 154	FR320X10	1	EPR 20
8-3/8	7-1/4	SAF 22238	SAF 238	22238	AN 38	W 38	LER 171	LER 160	FR340X10	1	EPR 21
8-3/4	7-5/8	SAF 22240	SAF 240	22240	AN 40	W 40	LER 175	LER 164	FR360X10	1	EPR 22
9-9/16	8-5/16	SAF 22244	SAF 244	22244	AN 44	W 44	LER 179	LER 170	FR400X10	1	EPR 24

Note: Housings available in cast iron (SAF), Ductile (SAFD) or cast steel (SAFS).
Taconite (TER) and LOR seals with O-rings are also available

- (a) "Housing Only" includes - cap, base, cap bolts, labyrinth seals and fixing rings
- (b) Fixing Ring is used for fixed block only; do not use for float mounting
- (c) End Cover is optional

Introduction

Ball Bearings

Cylindrical Roller Bearings

Spherical Roller Bearings

Tapered Roller Bearings

Thrust Bearings

Split Pillow Blocks

Super Precision Bearings

Linear Motion

Rolling Mill Bearings

Engineering Section

Pillow Block

SAF 300 Series

Housing No.	A	B	P	G	E		E1	H	L	Bolts (No. Req'd)	Wt.	D	F	d1	d2
	In.	In.	In.	In.	Max In.	Min In.	In.	In.	In.	In.	lbs.*	mm	mm	In.	In.
SAF 308	2-1/2	8-1/4	2-3/8	1	7	6-1/2		4-13/16	4	(2)-1/2	11.2	90	42.8	1-15/16	1-7/16
SAF 309	2-3/4	9-5/8	2-3/4	1	7-7/8	7-3/8		5-5-16	4-1/4	(2)-5/8	14.3	100	46	2-1/8	1-11/16
SAF 310	3	10-5/8	2-3/4	1-1/8	9	7-3/4		5-13/16	4-5/8	(2)-5/8	17.8	110	51	2-3/8	1-7/8
SAF 311	3-1/4	11	3-1/8	1-3/16	9-1/2	8-1/8		6-3/16	5	(2)-5/8	20.2	120	53	2-9/16	2-1/16
FSAF 311	3-1/4	11	3-1/8	1-3/16	9-1/2	8-1/8	2	6-3/16	5	(4)-1/2	20.2	120	53	2-9/16	2-1/16
SAF 313	3-1/2	13	3-1/2	1-1/4	11	9-5/8		6-15/16	5-3/8	(2)-3/4	28.6	140	58	3-1/16	2-7/16
FSAF 313	3-1/2	13	3-1/2	1-1/4	11	9-5/8	2-1/8	6-15/16	5-3/8	(4)-5/8	28.6	140	58	3-1/16	2-7/16
SAF 314	3-3/4	13	3-1/2	1-1/4	11	9-7/8		7-3/8	5-3/8	(2)-3/4	32.3	150	63	3-1/4	2-5/8
FSAF 314	3-3/4	13	3-1/2	1-1/4	11	9-7/8	2-1/8	7-3/8	5-3/8	(4)-5/8	32.3	150	63	3-1/4	2-5/8
SAF 315	4	13-3/4	3-7/8	1-5/16	11-5/8	10-3/8		7-13/16	6-1/4	(2)-3/4	39.6	160	65	3-7/16	2-13/16
FSAF 315	4	13-3/4	3-7/8	1-5/16	11-5/8	10-3/8	2-1/8	7-13/16	6-1/4	(4)-5/8	39.6	160	65	3-7/16	2-13/16
SAF 316	4-1/4	14-1/4	3-7/8	1-5/16	12-5/8	10-5/8		8-1/4	6-1/2	(2)-3/4	49.8	170	68	3-5/8	3
FSAF 316	4-1/4	14-1/4	3-7/8	1-5/16	12-5/8	10-5/8	2-1/8	8-1/4	6-1/2	(4)-5/8	49.8	170	68	3-5/8	3
SAF 317	4-1/2	15-1/4	4-3/8	1-3/4	13-1/8	11-5/8		8-3/4	6-3/4	(2)-7/8	53.7	180	70	3-15/16	3-3/16
FSAF 317	4-1/2	15-1/4	4-3/8	1-3/4	13-1/8	11-5/8	2-3/8	8-3/4	6-3/4	(4)-3/4	53.7	180	70	3-15/16	3-3/16
SAF 318	4-3/4	15-1/2	4-3/8	2	13-1/2	12	2-1/4	9-3/16	6-7/8	(4)-3/4	59	190	74	4-1/8	3-3/8
SAF 320	5-1/4	16-1/2	4-3/4	2-1/8	14-1/2	13-1/4	2-3/4	10-1/4	7-3/8	(4)-3/4	81.3	215	83	4-1/2	3-13/16
SAF 322	6	18-3/8	5-1/8	2-3/8	16	14-5/8	3-1/4	11-1/2	8	(4)-7/8	96.5	240	90	4-7/8	4-3/16
SAF 324	6-5/16	21-1/4	6-1/4	2-1/2	18-1/4	17	3-3/4	12-1/2	8-3/8	(4)-1	142.1	260	96	5-5/16	4-9/16
SAF 326	6-11/16	22	6-1/4	2-5/8	19-1/4	17-3/8	3-3/4	13-5/16	8-3/4	(4)-1	176.3	280	103	5-7/8	4-15/16
SAF 328	7-1/16	24-3/4	6-3/4	2-3/4	21-5/8	19-3/8	4-1/4	14-3/16	9-5/8	(4)-1	207.8	300	112	6-1/4	5-5/16
SAF 330	7-1/2	26-3/4	7-1/8	3	23-5/8	20-7/8	4-5/8	14-7/8	9-3/4	(4)-1	249.1	320	118	6-5/8	5-3/4
SAF 332	7-7/8	28	7-1/2	3-1/8	24-3/8	21-5/8	4-1/2	15-11/16	10-3/4	(4)-1 1/4	289.6	340	124	7	6-1/16
SAF 334	8-1/4	29-1/2	8	3-3/8	25	22-1/2	5	16-1/2	11-1/4	(4)-1 1/4	345.3	360	130	7-7/16	6-7/16
SAF 336	8-7/8	31-1/4	8-1/4	3-1/2	26-5/8	24	5-1/4	17-3/4	11-3/8	(4)-1 1/4	389.2	380	136	7-13/16	6-7/8
SAF 338	9-1/2	32-3/4	8-3/4	3-3/4	27-7/8	24-3/4	5-1/4	18-5/8	12	(4)-1 1/2	436.5	400	142	8-3/8	7-1/4
SAF 340	9-7/8	34-1/4	9	4	29-1/2	26-1/4	5-1/2	20	12-1/16	(4)-1 1/2	478.6	420	148	8-3/4	7-5/8

*Weights are approximate

Application Data
Spherical Roller Bearings – page 74

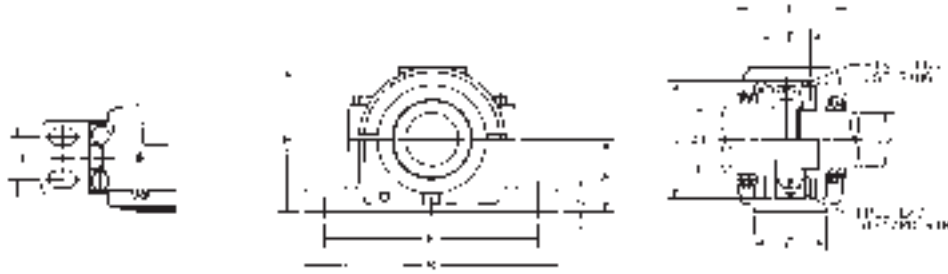

Shaft		Complete Unit Number	Housing Only ^(a)	Bearing Number	Locknut	Lockwasher	Labrynth Seals		Fixing Ring ^(b)		End Cover ^(c)
D1	D2						D1	D2	Size	Qty.	
1-15/16	1-7/16	SAF 1308	SAF 308	1308	N 08	W 08	LER 24	LER 17	FR90X10	2	EPR 03
		SAF 2308		2308					FR90X10	1	
		SAF 21308		21308					FR90X10.2	2	
		SAF 22308		22308					FR90X10	1	
2-1/8	1-11/16	SAF 1309	SAF 309	1309	N 09	W 09	LER 28	LER 20	FR100X10.5	2	EPR 04
		SAF 2309		2309					FR100X10	1	
		SAF 21309		21309					FR100X10.5	2	
		SAF 22309		22309					FR100X10	1	
2-3/8	1-7/8	SAF 1310	SAF 310	1310	N 10	W 10	LER 35	LER 23	FR110X11.5	2	EPR 05
		SAF 2310		2310					FR110X10	1	
		SAF 21310		21310					FR110X11.5	2	
		SAF 22310		22310					FR110X10	1	
2-9/16	2-1/16	SAF 1311	SAF 311	1311	N 11	W 11	LER 40	LER 27	FR120X12	2	EPR 06
		SAF 2311	FSAF 311	2311					FR120X10	1	
		SAF 21311	21311	FR120X12					2		
		SAF 22311	22311	FR120X10					1		
3-1/16	2-7/16	SAF 1313	SAF 313	1313	N 13	W 13	LER 55	LER 37	FR140X12.5	2	EPR 07
		SAF 2313	FSAF 313	2313					FR140X10	1	
		SAF 21313	21313	FR140X12.5					2		
		SAF 22313	22313	FR140X10					1		
3-1/4	2-5/8	SAF 1314	SAF 314	1314	N 14	W 14	TS314X3-1/4	TS314X2-5/8	FR150X12.5	2	---
		SAF 2314	2314	FR150X10			1				
		SAF 21314	21314	FR150X12.5			2				
		SAF 22314	22314	FR150X10			1				
3-7/16	2-13/16	SAF 1315	SAF 315	1315	N 15	W 15	LER 79	LER 46	FR160X14	2	EPR 08
		SAF 2315	FSAF 315	2315					FR160X10	1	
		SAF 21315	21315	FR160X14					2		
		SAF 22315	22315	FR160X10					1		
3-5/8	3	SAF 1316	SAF 316	1316	AN 16	W 16	LER 84	LER 60	FR170X14.5	2	EPR 10
		SAF 2316	FSAF 316	2316					FR170X10	1	
		SAF 21316	21316	FR170X14.5					2		
		SAF 22316	22316	FR170X10					1		
3-15/16	3-3/16	SAF 1317	SAF 317	1317	AN 17	W 17	LER 109	LER 188	FR180X14.5	2	EPR 11
		SAF 2317	FSAF 317	2317					FR180X10	1	
		SAF 21317	21317	FR180X14.5					2		
		SAF 22317	22317	FR180X10					1		
4-1/8	3-3/8	SAF 1318	SAF 318	1318	AN 18	W 18	LER 112	LER 191	FR190X15.5	2	EPR 11
		SAF 2318	FSAF 318	2318					FR190X10	1	
		SAF 21318	21318	FR190X15.5					2		
		SAF 22318	22318	FR190X10					1		
4-1/2	3-13/16	SAF 1320	SAF 320	1320	AN 20	W 20	LER 118	LER 106	FR215X18	2	EPR 12
		SAF 2320	FSAF 320	2320					FR215X10	1	
		SAF 21320	21320	FR215X18					2		
		SAF 22320	22320	FR215X10					1		
4-7/8	4-3/16	SAF 1322	SAF 322	1322	AN 22	W 22	LER 121	LER 113	FR240X20	2	EPR 14
		SAF 2322	2322	FR240X20					2		
		SAF 21322	21322	FR240X10					1		
		SAF 22322	22322	FR240X10					1		
5-5/16	4-9/16	SAF 22324	SAF 324	22324	AN 24	W 24	LER 127	LER 119	FR260X10	1	EPR 15
5-7/8	4-15/16	SAF 22326	SAF 326	22326	AN 26	W 26	LER 136	LER 122	FR280X10	1	EPR 27
6-1/4	5-15/16	SAF 22328	SAF 328	22328	AN 28	W 28	LER 144	LER 127	FR300X10	1	EPR 16
6-5/8	5-3/4	SAF 22330	SAF 330	22330	AN 30	W 30	LER 151	LER 134	FR320X10	1	EPR 17
7	6-1/16	SAF 22332	SAF 332	22332	AN 32	W 32	LER 156	LER 142	FR340X10	1	EPR 18
7-7/16	6-7/16	SAF 22334	SAF 334	22334	AN 34	W 34	LER 161	LER 148	FR360X10	1	EPR 19
7-13/16	6-7/8	SAF 22336	SAF 336	22336	AN 36	W 36	LER 165	LER 154	FR380X10	1	---
8-3/8	7-1/4	SAF 22338	SAF 338	22338	AN 38	W 38	LER 171	LER 160	FR400X10	1	EPR 21
8-3/4	7-5/8	SAF 22340	SAF 340	22340	AN 40	W 40	LER 175	LER 164	FR420X10	1	---

Note: Housings available in cast iron (SAF), Ductile (SAFD) or cast steel (SAFS).

Taconite (TER) and LOR seals with O-rings are also available

(a) "Housing Only" includes - cap, base, cap bolts, labyrinth seals and fixing rings

(b) Fixing Ring is used for fixed block only; do not use for float mounting

(c) End Cover is optional

Introduction

Ball Bearings

Cylindrical Roller Bearings

Spherical Roller Bearings

Tapered Roller Bearings

Thrust Bearings

Split Pillow Blocks

Super Precision Bearings

Linear Motion

Rolling Mill Bearings

Engineering Section

Pillow Block

SAF 500 Series

Housing No.	A	B	P	G	E		E1	H	L	X	Bolts (No. Req'd)	Wt.	D	F	d1
	In.	In.	In.	In.	Max In.	Min In.	In.	In.	In.	In.	In.	lbs.*	mm	mm	In.
SAF 507	2	7-1/2	2	7/8	6-1/8	5-5/8		3-7/8	3-1/4	1	(2)-1/2	7.2	80	8	1-3/16
SAF 509	2-1/4	8-1/4	2-3/8	13/16	7	6-1/4		4-3/8	3-5/8	.114	(2)-1/2	9.3	85	29	1-7/16
SAF 510	2-1/2	8-1/4	2-3/8	15/16	7	6-1/2		4-3/4	3-5/8	.133	(2)-1/2	10.2	90	30	1-11/16
SAF 511	2-3/4	9-5/8	2-3/4	15/16	7-7/8	7-3/8		5-1/4	3-7/8	.114	(2)-5/8	12.5	3100	31	1-15/16
SAF 513	3	11	3-1/8	1	9-1/2	8-1/8		5-15/16	4-1/2	.157	(2)-5/8	18.3	120	39	2-3/16
FSAF 513	3	11	3-1/8	1	9-1/2	8-1/8	2	5-15/16	4-1/2	.157	(4)-1/2	18.3	120	39	2-3/16
SAF 515	3-1/4	11-1/4	3-1/8	1-1/8	9-5/8	8-5/8		6-3/8	4-3/4	.118	(2)-5/8	18.3	130	37	2-7/16
FSAF 515	3-1/4	11-1/4	3-1/8	1-1/8	9-5/8	8-5/8	1-7/8	6-3/8	4-3/4	.118	(4)-1/2	18.3	130	37	2-7/16
SAF 516	3-1/2	13	3-1/2	1-3/16	11	9-5/8		6-7/8	4-7/8	.187	(2)-3/4	26.9	140	43	2-11/16
FSAF 516	3-1/2	13	3-1/2	1-3/16	11	9-5/8	2-1/8	6-7/8	4-7/8	.187	(4)-5/8	26.9	140	43	2-11/16
SAF 517	3-3/4	13	3-1/2	1-1/4	11	9-7/8		7-5/16	5	.187	(2)-3/4	29.8	150	46	2-15/16
FSAF 517	3-3/4	13	3-1/2	1-1/4	11	9-7/8	2-1/8	7-5/16	5	.187	(4)-5/8	29.8	150	46	2-15/16
SAF 518	4	13-3/4	3-7/8	1-5/16	11-5/8	10-3/8		7-3/4	5-3/4	.187	(2)-3/4	36.6	160	50	3-3/16
FSAF 518	4	13-3/4	3-7/8	1-5/16	11-5/8	10-3/8	2-1/8	7-3/4	5-3/4	.187	(4)-5/8	36.6	160	50	3-3/16
SAF 520	4-1/2	15-1/4	4-3/8	1-3/4	13-1/8	11-5/8		8-3/4	6-1/8	.187	(2)-7/8	50.2	180	56	3-7/16
FSAF 520	4-1/2	15-1/4	4-3/8	1-3/4	13-1/8	11-5/8	2-3/8	8-3/4	6-1/8	.187	(4)-3/4	50.2	180	56	3-7/16
SAF 522	4-15/16	16-1/2	4-3/4	2	14-1/2	12-5/8	2-3/4	9-5/8	6-1/2	.187	(4)-3/4	60.1	200	63	3-15/16
SAF 524	5-1/4	16-1/2	4-3/4	2-1/8	14-1/2	13-1/4	2-3/4	10-1/4	7-3/8	.187	(4)-3/4	71.2	215	68	4-3/16
SAF 526	6	18-3/4	5-1/8	2-3/8	16	14-5/8	3-1/4	11-1/2	8	.187	(4)-4/8	94.7	230	74	4-7/16
SAF 528	6	20-1/8	5-7/8	2-3/8	17-1/8	16	3-3/8	11-3/4	7-5/8	.187	(4)-1	110.2	250	78	4-15/16
SAF 530	6-5/16	21-1/4	6-1/4	2-1/2	18-1/4	17	3-3/4	12-1/2	8-3/8	.187	(4)-1	137.9	270	83	5-3/16
SAF 532	6-11/16	22	6-1/4	2-5/8	19-1/4	17-3/8	3-3/4	13-5/16	8-3/4	.187	(4)-1	157.6	290	90	5-7/16
SAF 534	7-1/16	24-3/4	6-3/4	2-3/4	21-5/8	19-3/8	4-1/4	14-3/16	9-5/8	.187	(4)-1	184.6	310	96	5-15/16
SAF 536	7-1/2	26-3/4	7-1/8	3	23-5/8	20-7/8	4-5/8	14-7/16	10	.187	(4)-1	217.1	320	96	6-7/16
SAF 538	7-7/8	28	7-1/2	3-1/8	24-3/8	21-5/8	4-1/2	15-11/16	10-3/4	.187	(4)-1 1/4	285	340	102	6-15/16
SAF 540	8-1/4	29-1/2	8	3-3/8	25	22-1/2	5	16-1/2	11-1/4	.187	(4)-1 1/4	330	360	108	7-3/16
SAF 544	9-1/2	32-3/4	8-3/4	3-3/4	27-7/8	24-3/4	5-1/4	18-5/8	12	.187	(4)-1 1/2	391.3	400	111	7-15/16

*Weights are approximate

Application Data

Spherical Roller Bearings – page 70

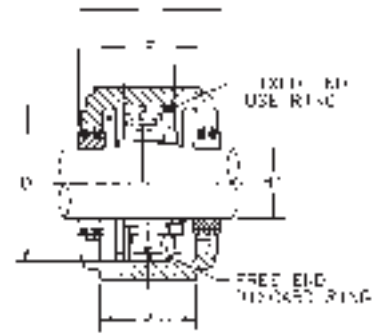
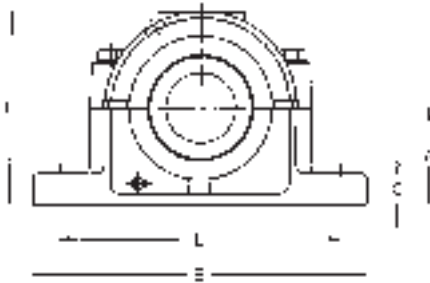

Shaft Size	Complete Unit Number	Housing Only ^(a)	Bearing Number	Adapters		Labrynth Seals		Fixing Ring ^(b)		End Cover ^(c)
				SNW Type	H Type	LER	Tactonite	Size	Qty.	
1-3/16	SAF 1507	SAF 507	1207K	SNW 07X1-3/16	HA 207X1-3/16	LER 13	---	FR72X8	2	---
	SAF 2507		2207K	SNW 07X1-3/16	HA 307X1-3/16			FR72X10	1	
1-7/16	SAF 1509	SAF 509	1209K	SNW 09X1-7/16	HA 209X1-7/16	LER 17	TER 17	FR85X5	2	EPR 03
	SAF 2509		2209K	SNW 09X1-7/16	HA 309X1-7/16			FR85X6	1	
1-11/16	SAF 1510	SAF 510	1210K	SNW 10X1-11/16	HA 210X1-11/16	LER 20	TER 20	FR90X5	2	EPR 04
	SAF 2510		2210K	SNW 10X1-11/16	HA 310X1-11/16			FR90X7	1	
1-15/16	SAF 1511	SAF 511	1211K	SNW 11X1-15/16	HA 211X1-15/16	LER 24	TER 24	FR100X5	2	EPR 05
	SAF 2511		2211K	SNW 11X1-15/16	HA 311X1-15/16			FR100X6	1	
2-3/16	SAF 1513	SAF 513	1213K	SNW 13X2-3/16	HA 213X2-3/16	LER 29	TER 29	FR120X8	2	EPR 06
	SAF 2513		FSAF 513	2213K	SNW 13X2-3/16			HA 313X2-3/16	FR120X8	
2-7/16	SAF 1515	SAF 515	1215K	SNW 15X2-7/16	HA 215X2-7/16	LER 37	TER 37	FR130X6	2	EPR 07
	SAF 2515		FSAF 515	2215K	SNW 15X2-7/16			HA 315X2-7/16	FR130X6	
2-11/16	SAF 1516	SAF 516	1216K	SNW 16X2-11/16	HA 216X2-11/16	LER 44	TER 44	FR140X8.5	2	EPR 08
	SAF 2516		FSAF 516	2216K	SNW 16X2-11/16			HA 316X2-11/16	FR140X10	
2-15/16	SAF 1517	SAF 517	1217K	SNW 17X2-15/16	HA 217X2-15/16	LER 53	TER 53	FR150X9	2	EPR 09
	SAF 2517		FSAF 517	2217K	SNW 17X2-15/16			HA 317X2-15/16	FR150X10	
3-3/16	SAF 1518	SAF 518	1218K	SNW 18X3-3/16	HA 218X3-3/16	LER 188	TER 188	FR160X10	2	EPR 11
	SAF 2518		FSAF 518	2218K	SNW 18X3-3/16			HA 318X3-3/16	FR160X10	
3-7/16	SAF 1520	SAF 520	1220K	SNW 20X3-7/16	HA 220X3-7/16	LER 102	TER 102	FR180X11	2	EPR 12
	SAF 2520		FSAF 520	2220K	SNW 20X3-7/16			HA 320X3-7/16	FR180X10	
3-15/16	SAF 1522	SAF 522	1222K	SNW 22X3-15/16	HA 222X3-15/16	LER 109	TER 109	FR200X12.5	2	EPR 13
	SAF 2522		2222K	SNW 22X3-15/16	HA 322X3-15/16			FR200X10	1	
4-3/16	SAF 22522	SAF 524	22222K	SNW 22X3-15/16	HA 322X3-15/16	LER 113	TER 113	FR200X10	1	EPR 14
4-7/16	SAF 22524	SAF 526	22224K	SNW 24X4-3/16	HA 3124X4-3/16	LER 117	TER 117	FR215X10	1	EPR 15
4-15/16	SAF 22526	SAF 528	22226K	SNW 26X4-7/16	HA 3126X4-7/16	LER 122	TER 122	FR230X10	1	EPR 16
5-3/16	SAF 22528	SAF 530	22228K	SNW 28X4-15/16	HA 3128X4-15/16	LER 125	TER 125	FR250X10	1	EPR 17
5-7/16	SAF 22530	SAF 532	22230K	SNW 30X5-3/16	HA 3130X5-3/16	LER 130	TER 130	FR270X10	1	EPR 18
5-15/16	SAF 22532	SAF 534	22232K	SNW 32X5-7/16	HA 3132X5-7/16	LER 140	TER 140	FR290X10	1	EPR 19
6-7/16	SAF 22534	SAF 536	22234K	SNW 34X5-15/16	HA 3134X5-15/16	LER 148	TER 148	FR310X10	1	EPR 20
6-15/16	SAF 22536	SAF 538	22236K	SNW 36X6-7/16	HA 3136X6-7/16	LER 155	TER 155	FR320X10	1	EPR 21
7-3/16	SAF 22538	SAF 540	22238K	SNW 38X6-15/16	HA 3138X6-15/16	LER 159	TER 159	FR340X10	1	EPR 22
7-15/16	SAF 22540	SAF 544	22240K	SNW 40X7-3/16	HA 3140X7-3/16	LER 167	TER 167	FR360X10	1	EPR 23
7-15/16	SAF 22544	SAF 544	22244K	SNW 44X7-15/16	HA 3144X7-15/16	LER 167	TER 167	FR400X10	1	EPR 24

Note: Housings available in cast iron (SAF), Ductile (SAFD) or cast steel (SAFS).

LOR seals with O-rings are also available

(a) "Housing Only" includes - cap, base, cap bolts, labyrinth seals and fixing rings

(b) Fixing Ring is used for fixed block only; do not use for float mounting

(c) End Cover is optional

Introduction

Ball Bearings

Cylindrical Roller Bearings

Spherical Roller Bearings

Tapered Roller Bearings

Thrust Bearings

Split Pillow Blocks

Super Precision Bearings

Linear Motion

Rolling Mill Bearings

Engineering Section

Pillow Block

SAF 600 Series

Housing No.	A	B	P	G	E		E1	H	L	Bolts (No. Req'd)	Wt.	D	F	d1
	In.	In.	In.	In.	Max In.	Min In.	In.	In.	In.	In.	lbs.*	mm	mm	In.
SAF 609	2-3/4	9-5/8	2-3/4	1	7-7/8	7-3/8		5-5/16	4-1/4	(2)-5/8	12.1	100	46	1-7/16
SAF 610	3	10-5/8	2-3/4	1-1/8	9	7-3/4		5-13/16	4-5/8	(2)-5/8	16.8	110	51	1-11/16
SAF 611	3-1/4	11	3-1/3	1-3/16	9-1/2	8-1/8		6-3/16	4-7/8	(2)-5/8	20.2	120	53	1-15/16
FSAF 611	3-1/4	11	3-1/3	1-3/16	9-1/2	8-1/8	2	6-3/16	4-7/8	(4)-1/2	20.2	120	53	1-15/16
SAF 613	3-1/2	13	3-1/2	1-1/4	11	9-5/8		6-15/16	5-3/8	(2)-3/4	28.7	140	58	2-3/16
FSAF 613	3-1/2	13	3-1/2	1-1/4	11	9-5/8	2-1/8	6-15/16	5-3/8	(4)-5/8	28.7	140	58	2-3/16
SAF 615	4	13-3/4	3-7/8	1-5/16	11-5/8	10-3/8		7-3/4	6-1/4	(2)-3/4	36.9	160	65	2-7/16
FSAF 615	4	13-3/4	3-7/8	1-5/16	11-5/8	10-3/8	2-1/8	7-3/4	6-1/4	(4)-5/8	36.9	160	65	2-7/16
SAF 616	4-1/4	14-1/4	3-7/8	1-5/16	12-5/8	10-5/8		8-1/4	6-1/2	(2)-3/4	47.6	170	68	2-11/16
FSAF 616	4-1/4	14-1/4	3-7/8	1-5/16	12-5/8	10-5/8	2-1/8	8-1/4	6-1/2	(4)-5/8	47.6	170	68	2-11/16
SAF 617	4-1/2	15-1/4	4-3/8	1-3/4	13-1/8	11-5/8		8-3/4	6-3/4	(2)-7/8	57.4	180	70	2-15/16
FSAF 617	4-1/2	15-1/4	4-3/8	1-3/4	13-1/8	11-5/8	2-3/8	8-3/4	6-3/4	(4)-3/4	57.4	180	70	2-15/16
SAF 618	4-3/4	15-1/2	4-3/8	2	13-1/2	12	2-1/4	9-3/16	6-7/8	(4)-3/4	62.8	190	74	3-3/16
SAF 620	5-1/4	16-1/2	4-3/4	2-1/8	14-1/2	13-1/4	2-3/4	10-1/4	7-3/8	(4)-3/4	77.1	215	83	3-7/16
SAF 622	6	18-3/8	5-1/8	2-3/8	16	14-5/8	3	11-1/2	8	(4)-7/8	107.4	240	90	3-15/16
SAF 624	6-5/16	21-1/4	6-1/4	2-1/2	18-1/4	17	3-3/4	12-1/2	8-3/8	(4)-1	145.9	260	96	4-3/16
SAF 626	6-11/16	22	6-1/4	2-5/8	19-1/4	17-3/8	3-3/4	13-5-16	8-3/4	(4)-1	164.7	280	103	4-7/16
SAF 628	7-1/16	24-3/4	6-3/4	2-3/4	21-5/8	19-3/8	4-1/4	14-3/16	9-5/8	(4)-1	192.9	300	112	4-15/16
SAF 630	7-1/2	26-3/4	7-1/8	3	23-5/8	20-7/8	4-5/8	14-7/8	9-3/4	(4)-1	259.5	320	116	5-3/16
SAF 632	7-7/8	28	7-1/2	3-1/8	24-3/8	21-5/8	4-1/2	15-11/16	10-3/4	(4)-1 1/4	268.9	340	124	5-7/16
SAF 634	8-1/4	29-1/2	8	3-3/8	25	22-1/2	5	16-1/2	11-1/4	(4)-1 1/4	306.4	360	130	5-15/16
SAF 636	8-7/8	31-1/4	8-1/4	3-1/2	26-5/8	24	5-1/4	17-3/4	11-3/8	(4)-1 1/4	374.8	380	136	6-7/16
SAF 638	9-1/2	32-3/4	8-3/4	3-3/4	27-7/8	24-3/4	5-1/4	18-5/8	12	(4)-1 1/2	441	400	142	6-15/16
SAF 640	9-7/8	34-1/4	9	4	29-1/2	26-1/4	5-1/2	20	12-1/16	(4)-1 1/2	489.9	420	148	7-3/16

*Weights are approximate

Application Data

Spherical Roller Bearings – page 74

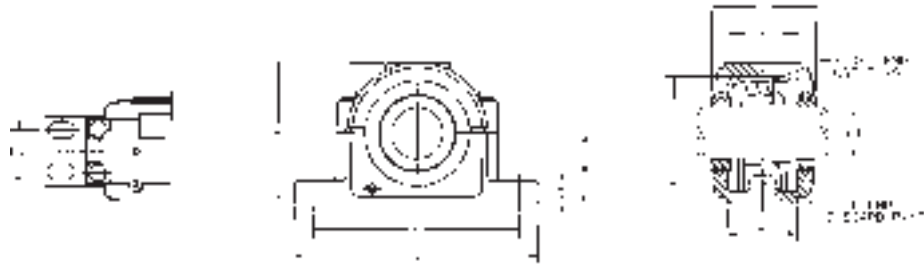

Shaft Size	Complete Unit Number	Housing Only ^(a)	Bearing Number	Adapters		Labrynth Seals		Fixing Ring ^(b)		End Cover ^(c)
				SNW Type	H Type	LER	Tactonite	Size	Qty.	
1-7/16	SAF 1609	SAF 609	1309K	SNW 09X1-7/16	HA 309X1-7/16	LER 17	TER 17	FR100X10.5	2	EPR 03
	SAF 2609		2309K	SNW 09X1-7/16	HA 2309X1-7/16			FR100X10	1	
	SAF 21609		21309K	SNW 09X1-7/16	HA 309X1-7/16			FR100X10.5	2	
1-11/16	SAF 22609	SAF 610	22309K	SNW 109X1-7/16	HA 2309X1-7/16	LER 20	TER 20	FR100X10	1	EPR 04
	SAF 1610		1310K	SNW 10X1-11/16	HA 310X1-11/16			FR110X11.5	2	
	SAF 2610		2310K	SNW 10X1-11/16	HA 2310X1-11/16			FR110X10	1	
	SAF 21610		21310K	SNW 10X1-11/16	HA 310X1-11/16			FR110X11.5	2	
1-15/16	SAF 22610	SAF 611 FSAF 611	22310K	SNW 110X1-11/16	HA 2310X1-11/16	LER 24	TER 24	FR110X10	1	EPR 05
	SAF 1611		1311K	SNW 11X1-15/16	HA 311X1-15/16			FR120X12	2	
	SAF 2611		2311K	SNW 11X1-15/16	HA 2311X1-15/16			FR120X10	1	
	SAF 21611		21311K	SNW 11X1-15/16	HA 311X1-15/16			FR120X12	2	
2-3/16	SAF 22611	SAF 613 FSAF 613	22311K	SNW 111X1-15/16	HA 2311X1-15/16	LER 32	---	FR120X10	1	EPR 07
	SAF 1613		1313K	SNW 13X2-3/16	HA 313X2-3/16			FR140X12.5	2	
	SAF 2613		2313K	SNW 13X2-3/16	HA 2313X2-3/16			FR140X10	1	
	SAF 21613		21313K	SNW 13X2-3/16	HA 313X2-3/16			FR140X12.5	2	
2-7/16	SAF 22613	SAF 615 FSAF 615	22313K	SNW 113X2-3/16	HA 2313X2-3/16	LER 37	TER 37	FR140X10	1	EPR 07
	SAF 1615		1315K	SNW 15X2-7/16	HA 315X2-7/16			FR160X14	2	
	SAF 2615		2315K	SNW 15X2-7/16	HA 2315X2-7/16			FR160X10	1	
	SAF 21615		21315K	SNW 15X2-7/16	HA 315X2-7/16			FR160X14	2	
2-11/16	SAF 22615	SAF 616 FSAF 616	22315K	SNW 115X2-7/16	HA 2315X2-7/16	LER 44	TER 44	FR160X10	1	EPR 08
	SAF 1616		1316K	SNW 16X2-11/16	HA 316X2-11/16			FR170X14.5	2	
	SAF 2616		2316K	SNW 16X2-11/16	HA 2316X2-11/16			FR170X10	1	
	SAF 21616		21316K	SNW 16X2-11/16	HA 316X2-11/16			FR170X14.5	2	
2-15/16	SAF 22616	SAF 617 FSAF 617	22316K	SNW 116X2-11/16	HA 2316X2-11/16	LER 184	---	FR170X10	1	EPR 10
	SAF 1617		1317K	SNW 17X2-15/16	HA 317X2-15/16			FR180X14.5	2	
	SAF 2617		2317K	SNW 17X2-15/16	HA 2317X2-15/16			FR180X10	1	
	SAF 21617		21317K	SNW 17X2-15/16	HA 317X2-15/16			FR180X14.5	2	
3-3/16	SAF 22617	SAF 618	22317K	SNW 117X2-15/16	HA 2317X2-15/16	LER 188	TER 188	FR180X10	1	EPR 11
	SAF 1618		1318K	SNW 18X3-3/16	HA 318X3-3/16			FR190X15.5	2	
	SAF 2618		2318K	SNW 18X3-3/16	HA 2318X3-3/16			FR190X10	1	
	SAF 21618		21318K	SNW 18X3-3/16	HA 318X3-3/16			FR190X15.5	2	
3-7/16	SAF 22618	SAF 620	22318K	SNW 118X3-3/16	HA 2318X3-3/16	LER 102	TER 102	FR190X10	1	EPR 12
	SAF 1620		1320K	SNW 20X3-7/16	HA 320X3-7/16			FR215X18	2	
	SAF 2620		2320K	SNW 20X3-7/16	HA 2320X3-7/16			FR215X10	1	
	SAF 21620		21320K	SNW 20X3-7/16	HA 320X3-7/16			FR215X18	2	
3-15/16	SAF 22620	SAF 622	22320K	SNW 120X3-7/16	HA 2320X3-7/16	LER 109	TER 109	FR215X10	1	EPR 13
	SAF 1622		1322K	SNW 22X3-15/16	HA 322X3-15/16			FR240X20	2	
	SAF 2622		21322K	SNW 22X3-15/16	HA 2322X3-15/16			FR240X20	2	
	SAF 21622		22322K	SNW 122X3-15/16	HA 3222X3-15/16			FR240X10	1	
4-3/16	SAF 22624	SAF 624	22324K	SNW 124X4-3/16	HA 2324X4-3/16	LER 113	TER 113	FR260X10	1	EPR 14
4-7/16	SAF 22626	SAF 626	22326K	SNW 126X4-7/16	HA 2326X4-7/16	LER 117	TER 117	FR280X10	1	EPR 15
4-15/16	SAF 22628	SAF 628	22328K	SNW 128X4-15/16	HA 2328X4-15/16	LER 122	TER 122	FR300X10	1	EPR 27
5-3/16	SAF22630	SAF 630	22330K	SNW 130X5-3/16	HA 2330X5-3/16	LER 125	TER 125	FR320X10	1	EPR 16
5-7/16	SAF 22632	SAF 632	22332K	SNW 132X5-7/16	HA 2332X5-7/16	LER 130	TER 130	FR340X10	1	EPR 16
5-15/16	SAF 22634	SAF 634	22334K	SNW 134X5-15/16	HA 2334X5-15/16	LER 140	TER 140	FR360X10	1	EPR 18
6-7/16	SAF 22636	SAF 636	22336K	SNW 136X6-7/16	HA 2336X6-7/16	LER 148	TER 148	FR380X10	1	---
6-15/16	SAF 22638	SAF 638	22338K	SNW 138X6-15/16	HA 2338X6-15/16	LER 155	TER 155	FR400X10	1	EPR 20
7-3/16	SAF 22640	SAF 640	22340K	SNW 140X7-3/16	HA 2340X7-3/16	LER 159	---	FR420X10	1	---

Note: Housings available in cast iron (SAF), Ductile (SAFD) or cast steel (SAFS).

LOR seals with O-rings are also available

(a) "Housing Only" includes - cap, base, cap bolts, labyrinth seals and fixing rings

(b) Fixing Ring is used for fixed block only; do not use for float mounting

(c) End Cover is optional

Introduction

Ball Bearings

Cylindrical Roller Bearings

Spherical Roller Bearings

Tapered Roller Bearings

Thrust Bearings

Split Pillow Blocks

Super Precision Bearings

Linear Motion

Rolling Mill Bearings

Engineering Section

167

Pillow Block

SDAF 000K Series

Housing No.	A	B	P	G	E		E1	H	K Static Oil Level	L	Bolts (No. Req'd)	Wt.
	In.	In.	In.	In.	Max In.	Min In.	In.	In.	In.	In.	In	lbs.*
SDAF 060K/10-15/16	12	38-1/4	14-3/4	3-3/8	33-1/2	32-3/4	9	23-7/16	4-3/8	14-1/2	(4)--1-5/8	875
SDAF 060K/11	12	38-1/4	14-3/4	3-3/8	33-1/2	32-3/4	9	23-7/16	4-3/8	14-1/2	(4)--1-5/8	875
SDAF 064K/11-7/16	12	38-1/4	14-3/4	3-3/8	33-1/2	32-3/4	9	23-7/16	4	15-1/2	(4)--1-5/8	878
SDAF 064K/11-1/2	12	38-1/4	14-3/4	3-3/8	33-1/2	32-3/4	9	23-7/16	4	15-1/2	(4)--1-5/8	878
SDAF 064K/11-15/16	12	38-1/4	14-3/4	3-3/8	33-1/2	32-3/4	9	23-7/16	4	15-1/2	(4)--1-5/8	878
SDAF 064K/12	12	38-1/4	14-3/4	3-3/8	33-1/2	32-3/4	9	23-7/16	4	15-1/2	(4)--1-5/8	878
SDAF 068K/12-7/16	12	39	15-1/4	4-3/16	33-1/2	32	10	24	3-3/8	15-3/4	(4)--1-7/8	1100
SDAF 068K/12-1/2	12	39	15-1/4	4-3/16	33-1/2	32	10	24	3-3/8	15-3/4	(4)--1-7/8	1100
SDAF 072K/12-15/16	12-13/16	41-3/4	15-3/4	4-1/2	36-1/2	35	10-1/2	25-3/4	3-23/32	16-1/4	(4)--1-7/8	1170
SDAF 072K/13	12-13/16	41-3/4	15-3/4	4-1/2	36-1/2	35	10-1/2	25-3/4	3-23/32	16-1/4	(4)--1-7/8	1170
SDAF 072K/13-7/16	12-13/16	41-3/4	15-3/4	4-1/2	36-1/2	35	10-1/2	25-3/4	3-23/32	16-1/4	(4)--1-7/8	1170
SDAF 072K/13-1/2	12-13/16	41-3/4	15-3/4	4-1/2	36-1/2	35	10-1/2	25-3/4	3-23/32	16-1/4	(4)--1-7/8	1170
SDAF 076K/13-15/16	12-13/16	41-3/4	15-3/4	4-1/2	36-1/2	35	10-1/2	25-3/4	3-3/8	16-1/4	(4)--1-7/8	1146
SDAF 076K/14	12-13/16	41-3/4	15-3/4	4-1/2	36-1/2	35	10-1/2	25-3/4	3-3/8	16-1/4	(4)--1-7/8	1146

*Weights are approximate

Application Data

Spherical Roller Bearings – page 78

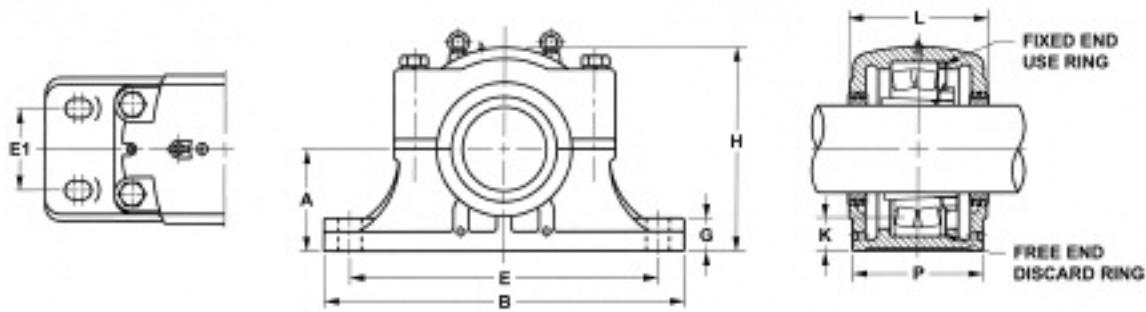

Shaft Diameter S-1 in	Complete Unit Number	Housing Only ^(a)	Bearing Number	Adapter Locknut and Lockwasher or Lockplate	Labyrinth Seal Ring (2 required)	Fixing Ring ^(b) (1 required)
10-15/16	SDAF 23060K/10-15/16	SDAF 060K/10-15/16	23060 K	SNP3060 X 10-15/16	ER 858	A 8967
11	SDAF 23060K/11	SDAF 060K/11	23060 K	SNP3060 X 11	ER 825	A 8967
11-7/16	SDAF 23064K/11-7/16	SDAF 064K/11-7/16	23064 K	SNP3064 X 11-7/16	ER 861	A 8968
11-1/2	SDAF 23064K/11-1/2	SDAF 064K/11-1/2	23064 K	SNP3064 X 11-1/2	ER 832	A 8968
11-15/16	SDAF 23064K/11-15/16	SDAF 064K/11-15/16	23064 K	SNP3064 X 11-15/16	ER 859	A 8968
12	SDAF 23064K/12	SDAF 064K/12	23064 K	SNP3064 X 12	ER 818	A 8968
12-7/16	SDAF 23068K/12-7/16	SDAF 068K/12-7/16	23068 K	SNP3068 X 12-7/16	ER 865	A 8969
12-1/2	SDAF 23068K/12-1/2	SDAF 068K/12-1/2	23068 K	SNP3068 X 12-1/2	ER 866	A 8969
12-15/16	SDAF 23072K/12-15/16	SDAF 072K/12-15/16	23072 K	SNP3072 X 12-15/16	ER 869	A 8970
13	SDAF 23072K/13	SDAF 072K/13	23072 K	SNP3072 X 13	ER 846	A 8970
13-7/16	SDAF 23072K/13-7/16	SDAF 072K/13-7/16	23072 K	SNP3072 X 13-7/16	ER 872	A 8970
13-1/2	SDAF 23072K/13-1/2	SDAF 072K/13-1/2	23072 K	SNP3072 X 13-1/2	ER 823	A 8970
13-15/16	SDAF 23076K/13-15/16	SDAF 076K/13-15/16	23076 K	SNP3076 X 13-15/16	ER 875	A 8971
14	SDAF 23076K/14	SDAF 076K/14	23076 K	SNP3076 X 14	ER 876	A 8971

Note: Housings available in cast iron (SDAF), Ductile (SDAFD) or cast steel (SDAFS).

Taconite (TER) and LOR seals with O-rings are also available

(a) "Housing Only" includes - cap, base, cap bolts, labyrinth seals and fixing rings

(b) Fixing Ring is used for fixed block only; do not use for float mounting

Pillow Block

SDAF 200 Series

Housing No.	A	B	P	G	E		E1	H	K Static Oil Level	L	Bolts (No. Req'd)	Wt.
	In.	In.	In.	In.	Max In.	Min In.	In.	In.	In.	In.	In	lbs.*
SDAF 220	4-1/2	15-1/4	6	1-7/8	13-1/8	11-5/8	3-3/8	8-15/16	1-3/4	6-3/4	(4)--3/4	60
SDAF 222	4-15/16	16-1/2	6-3/4	2-1/8	14-1/2	12-5/8	4	9-7/8	1-7/8	7-1/4	(4)--7/8	90
SDAF 224	5-1/4	16-1/2	6-7/8	2-1/4	14-1/2	13-1/4	4-1/8	10-1/2	1-15/16	7-3/8	(4)--7/8	100
SDAF 226	6	18-3/8	7-1/2	2-3/8	16	14-5/8	4-1/2	11-7/8	2-7/16	8	(4)--1	140
SDAF 228	6	20-1/8	7-1/2	2-3/8	17-1/8	16	4-1/2	12-1/16	2-1/8	7-15/16	(4)--1	147
SDAF 230	6-5/16	21-1/4	7-7/8	2-1/2	18-1/4	17	4-3/4	12-13/16	2-3/16	8-3/8	(4)--1-1/8	157
SDAF 232	6-11/16	22	8-1/4	2-1/2	19-1/4	17-3/8	5	13-11/16	2-3/16	8-3/4	(4)--1-1/8	183
SDAF 234	7-1/16	24-3/4	9	2-1/2	21-5/8	19-3/8	5-1/2	14-1/4	2-5/16	9-5/8	(4)--1-1/4	212
SDAF 236	7-1/2	26-3/4	9-3/8	2-3/4	23-5/8	20-7/8	5-7/8	15-3/16	2-9/16	10	(4)--1-1/4	247
SDAF 238	7-7/8	27-5/8	10	3	23-1/2	21-1/2	6-1/4	16-1/4	2-5/8	10-5/8	(4)--1-3/8	335
SDAF 240	8-1/4	28-3/4	10-1/2	3-1/4	25	23	6-3/4	17-1/8	2-11/16	11-1/8	(4)--1-3/8	343
SDAF 244	9-1/2	32	11-1/4	3-1/2	27-7/8	25-5/8	7-1/4	19-1/4	3-3/8	11-7/8	(4)--1-1/2	515

*Weights are approximate

Application Data

Spherical Roller Bearings – page 70

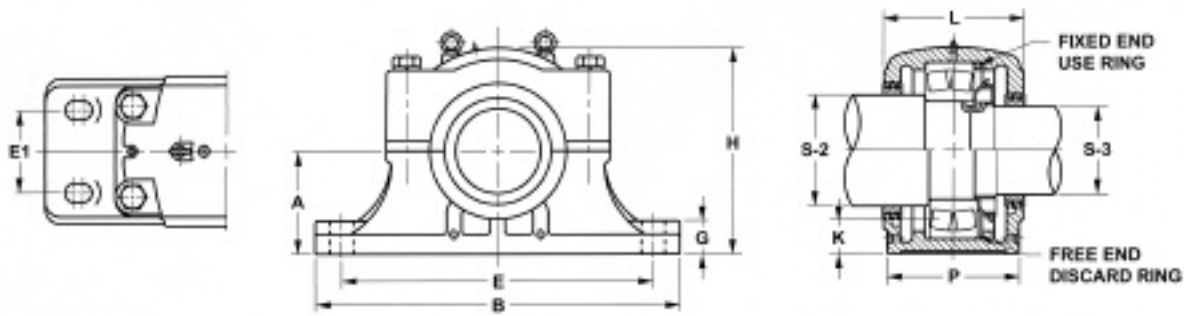

Shaft Diameter		Complete Unit Number	Housing Only ^(a)	Bearing Number	Locknut	Lockwasher	Labyrinth Seal Ring		Fixing Ring ^(b) (1 required)	End Cover ^(c)
S-2 in.	S-3 in.						S-2 Shaft (1 required)	S-3 Shaft (1 required)		
4-1/2	3-13/16	SDAF 22220	SDAF 220	22220	AN 20	W 20	LER 205	LER 87	FR180X10	EPR 12
4-7/8	4-3/16	SDAF 22222	SDAF 222	22222	AN 22	W 22	LER 121	LER 113	FR200X10	EPR 14
5-5/16	4-9/16	SDAF 22224	SDAF 224	22224	AN 24	W 24	LER 127	LER 119	FR215X10	EPR 15
5-7/8	4-15/16	SDAF 22226	SDAF 226	22226	AN 26	W 26	LER 136	LER 122	FR230X10	EPR 27
6-1/4	5-5/16	SDAF 22228	SDAF 228	22228	AN 28	W 28	LER 144	LER 127	FR250X10	---
6-5/8	5-3/4	SDAF 22230	SDAF 230	22230	AN 30	W 30	LER 151	LER 134	FR270X10	EPR 17
7	6-1/16	SDAF 22232	SDAF 232	22232	AN 32	W 32	LER 156	LER 142	FR290X10	EPR 18
7-7/16	6-7/16	SDAF 22234	SDAF 234	22234	AN 34	W 34	LER 161	LER 148	FR310X10	EPR 19
7-13/16	6-7/8	SDAF 22236	SDAF 236	22236	AN 36	W 36	LER 165	LER 154	FR320X10	EPR 20
8-3/8	7-1/4	SDAF 22238	SDAF 238	22238	AN 38	W 38	LER 240	LER 229	FR340X10	EPR 22
8-3/4	7-5/8	SDAF 22240	SDAF 240	22240	AN 40	W 40	LER 244	LER 233	FR360X10	EPR 23
9-9/16	8-5/16	SDAF 22244	SDAF 244	22244	N 44	W 44	LER 248	LER 239	FR400X10	EPR 25

Note: Housings available in cast iron (SDAF), Ductile (SDAFD) or cast steel (SDAFS).

Taconite (TER) and LOR seals with O-rings are also available

(a) "Housing Only" includes - cap, base, cap bolts, labyrinth seals and fixing rings

(b) Fixing Ring is used for fixed block only; do not use for float mounting

(c) End Cover is optional

Pillow Block

SDAF 300 Series

Housing No.	A	B	P	G	E		E1	H	K Static Oil Level	L	Bolts (No. Req'd)	Wt.
	In.	In.	In.	In.	Max In.	Min In.	In.	In.	In.	In.	In	lbs.*
SDAF 316	4-1/4	14-1/4	5-1/2	1-3/4	12-5/8	10-5/8	3-1/4	8-1/4	1-3/4	6-3/8	(4)--5/8	51
SDAF 317	4-1/2	15-1/4	6	1-7/8	13-1/8	11-5/8	3-3/8	8-15/16	1-13/16	6-3/4	(4)--3/4	63
SDAF 318	4-3/4	15-1/2	6-1/8	2	13-1/2	12	3-5/8	9-7/16	2	6-7/8	(4)--3/4	72
SDAF 320	5-1/4	16-1/2	6-7/8	2-1/4	14-1/2	13-1/4	4-1/8	10-1/2	2-1/8	7-3/8	(4)--7/8	92
SDAF 322	6	18-3/8	7-1/2	2-3/8	16	14-5/8	4-1/2	11-7/8	2-1/2	8	(4)--1	145
SDAF 324	6-5/16	21-1/4	7-7/8	2-1/2	18-1/4	17	4-3/4	12-13/16	2-9/16	8-3/8	(4)--1-1/8	170
SDAF 326	6-11/16	22	8-1/4	2-1/2	19-1/4	17-3/8	5	13-11/16	2-5/8	8-3/4	(4)--1-1/8	190
SDAF 328	7-1/16	24-3/4	9	2-1/2	21-5/8	19-3/8	5-1/2	14-1/4	2-11/16	9-3/8	(4)--1-1/4	228
SDAF 330	7-1/2	26-3/4	9-3/8	2-3/4	23-5/8	20-7/8	5-7/8	15-3/16	2-7/8	9-3/4	(4)--1-1/4	300
SDAF 332	7-7/8	27-5/8	10	3	23-1/2	21-1/2	6-1/4	16-1/4	2-15/16	10-5/8	(4)--1-3/8	350
SDAF 334	8-1/4	28-3/4	10-1/2	3-1/4	25	23	6-3/4	17-1/8	3-1/16	11-1/8	(4)--1-3/8	390
SDAF 336	8-7/8	30-1/2	10-3/4	3-1/4	26-3/8	24-1/8	6-7/8	17-15/16	3-3/8	11-3/8	(4)--1-1/2	400
SDAF 338	9-1/2	32	11-1/4	3-1/2	27-7/8	25-5/8	7-1/4	19-1/4	3-11/16	11-7/8	(4)--1-1/2	520
SDAF 340	9-7/8	33-1/2	11-3/4	3-1/2	29-1/4	26-5/8	7-5/8	19-15/16	3-3/4	12-3/8	(4)--1-5/8	560

*Weights are approximate

Application Data

Spherical Roller Bearings – page 74

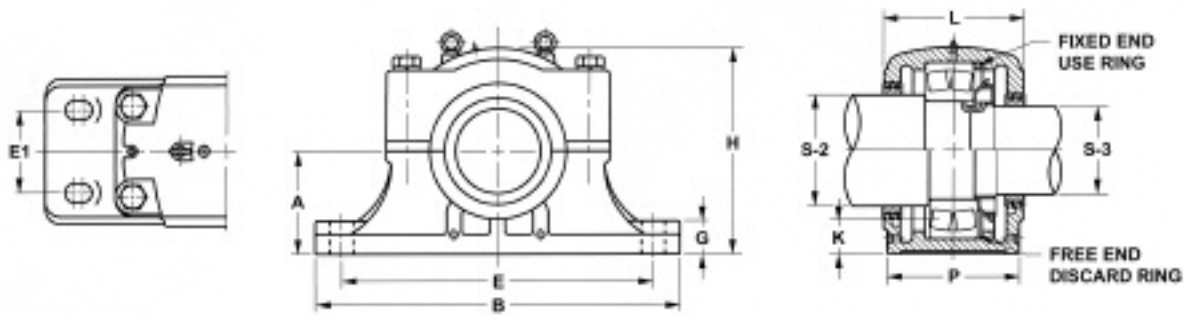

Shaft Diameter		Complete Unit Number	Housing Only ^(a)	Bearing Number	Locknut	Lockwasher	Labyrinth Seal Ring		Fixing Ring ^(b) (1 required)	End Cover ^(c)
S-2 in.	S-3 in.						S-2 Shaft (1 required)	S-3 Shaft (1 required)		
3-5/8	3	SDAF 22316	SDAF 316	22316	AN 16	W 16	LER 84	LER 60	FR170X10	EPR 10
3-15/16	3-3/16	SDAF 22317	SDAF 317	22317	AN 17	W 17	LER 93	LER 69	FR180X10	EPR 11
4-1/8	3-3/8	SDAF 22318	SDAF 318	22318	AN 18	W 18	LER 96	LER 72	FR190X10	EPR 11
4-1/2	3-13/16	SDAF 22320	SDAF 320	22320	AN 20	W 20	LER 205	LER 87	FR218X10	EPR 12
4-7/8	4-3/16	SDAF 22322	SDAF 322	22322	AN 22	W 22	LER 121	LER 113	FR240X10	EPR 14
5-5/16	4-9/16	SDAF 22324	SDAF 324	22324	AN 24	W 24	LER 127	LER 119	FR260X10	EPR 15
5-7/8	4-15/16	SDAF 22326	SDAF 326	22326	AN 26	W 26	LER 136	LER 122	FR280X10	EPR 27
6-1/4	5-5/16	SDAF 22328	SDAF 328	22328	AN 28	W 28	LER 144	LER 127	FR300X10	EPR 16
6-5/8	5-3/4	SDAF 22330	SDAF 330	22330	AN 30	W 30	LER 151	LER 134	FR320X10	EPR 17
7	6-1/16	SDAF 22332	SDAF 332	22332	AN 32	W 32	LER 225	LER 217	FR340X10	EPR 19
7-7/16	6-7/16	SDAF 22334	SDAF 334	22334	AN 34	W 34	LER 230	LER 220	FR360X10	EPR 26
7-16/16	6-7/8	SDAF 22336	SDAF 336	22336	AN 36	W 36	LER 234	LER 223	FR380X10	EPR 21
8-3/8	7-1/4	SDAF 22338	SDAF 338	22338	AN 38	W 38	LER 240	LER 229	FR400X10	EPR 22
8-3/4	7-5/8	SDAF 22340	SDAF 340	22340	AN 40	W 40	LER 244	LER 233	FR420X10	EPR 23

Note: Housings available in cast iron (SDAF), Ductile (SDAFD) or cast steel (SDAFS).

Taconite (TER) and LOR seals with O-rings are also available

(a) "Housing Only" includes - cap, base, cap bolts, labyrinth seals and fixing rings

(b) Fixing Ring is used for fixed block only; do not use for float mounting

(c) End Cover is optional

Pillow Block

SDAF 500 Series

Housing No.	A	B	P	G	E		E1	H	K Static Oil Level	L	Bolts (No. Req'd)	Wt.
	In.	In.	In.	In.	Max In.	Min In.	In.	In.	In.	In.	In	lbs.*
SDAF 520	4-1/2	15-1/4	6	1-7/8	13-1/8	11-5/8	3-3/8	8-15/16	1-3/4	6-3/4	(4)--3/4	64
SDAF 522	4-15/16	16-1/2	6-3/4	2-1/8	14-1/2	12-5/8	4	9-7/8	1-7/8	7-1/4	(4)--7/8	84
SDAF 524	5-1/4	16-1/2	6-7/8	2-1/4	14-1/2	13-1/4	4-1/8	10-1/2	1-15/16	7-3/8	(4)--7/8	97
SDAF 526	6	18-3/8	7-1/2	2-3/8	16	14-5/8	4-1/2	11-7/8	2-7/16	8	(4)--1	130
SDAF 528	6	20-1/8	7-1/2	2-3/8	17-1/8	16	4-1/2	12-1/16	2-1/8	7-15/16	(4)--1-1/8	146
SDAF 530	6-5/16	21-1/4	7-7/8	2-1/2	18-1/4	17	4-3/4	12-13/16	2-3/16	8-3/8	(4)--1-1/8	158
SDAF 532	6-11/16	22	8-1/4	2-1/2	19-1/4	17-3/8	5	13-11/16	2-3/16	8-3/4	(4)--1-1/8	187
SDAF 534	7-1/16	24-3/4	9	2-1/2	21-5/8	19-3/8	5-1/2	14-1/4	2-5/16	9-5/8	(4)--1-1/4	212
SDAF 536	7-1/2	26-3/4	9-3/8	2-3/4	23-5/8	20-7/8	5-7/8	15-3/16	2-9/16	10	(4)--1-1/4	292
SDAF 538	7-7/8	27-5/8	10	3	23-1/2	21-1/2	6-1/4	16-1/4	2-5/8	10-5/8	(4)--1-3/8	338
SDAF 540	8-1/4	28-3/4	10-1/2	3-1/4	25	23	6-3/4	17-1/8	2-11/16	11-1/8	(4)--1-3/8	340
SDAF 544	9-1/2	32	11-1/4	3-1/2	27-7/8	25-5/8	7-1/4	19-1/4	3-3/8	11-7/8	(4)--1-1/2	510

*Weights are approximate

Application Data

Spherical Roller Bearings – page 70

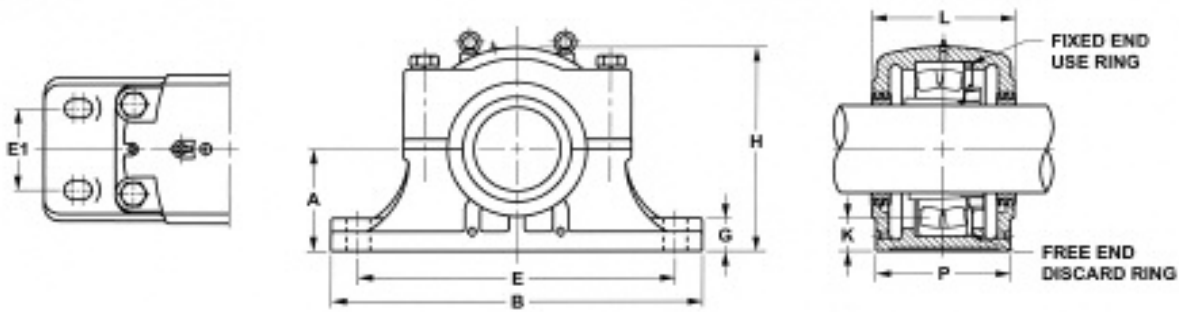

Shaft Diameter S-1 in.	Complete Unit Number	Housing Only ^(a)	Bearing Number	Adapter Locknut and Lockwasher	Labyrinth Seal Ring (2 required)	Fixing Ring ^(b) (1 required)	End Cover ^(c)
3-7/16	SDAF 22520	SDAF 520	22220 K	SNW20 X 3-7/16	LER 75	FR180X10	EPR11
3-15/16	SDAF 22522	SDAF 522	22222 K	SNW22 X 3-15/16	LER 93	FR200X10	EPR13
4-3/16	SDAF 22524	SDAF 524	22224 K	SNW24 X 4-3/16	LER 113	FR218X10	EPR14
4-7/16	SDAF 22526	SDAF 526	22226 K	SNW26 X 4-7/16	LER 117	FR230X10	EPR15
4-15/16	SDAF 22528	SDAF 528	22228 K	SNW28 X 4-15/16	LER 122	FR250X10	---
5-3/16	SDAF 22530	SDAF 530	22230 K	SNW30 X 5-3/16	LER 125	FR270X10	EPR16
5-7/16	SDAF 22532	SDAF 532	22232 K	SNW32 X 5-7/16	LER 130	FR290X10	EPR16
5-15/16	SDAF 22534	SDAF 534	22234 K	SNW34 X 5-15/16	LER 140	FR310X10	EPR18
6-7/16	SDAF 22536	SDAF 536	22236 K	SNW36 X 6-7/16	LER 148	FR320X10	EPR19
6-15/16	SDAF 22538	SDAF 538	22238 K	SNW38 X 6-15/16	LER 224	FR340X10	EPR21
7-3/16	SDAF 22540	SDAF 540	22240 K	SNW40 X 7-3/16	LER 228	FR360X10	EPR22
7-15/16	SDAF 22544	SDAF 544	22244 K	SNW44 X 7-15/16	LER 236	FR400X10	EPR24

Note: Housings available in cast iron (SDAF), Ductile (SDAFD) or cast steel (SDAFS).

Taconite (TER) and LOR seals with O-rings are also available

(a) "Housing Only" includes - cap, base, cap bolts, labyrinth seals and fixing rings

(b) Fixing Ring is used for fixed block only; do not use for float mounting

(c) End Cover is optional

Pillow Block

SDAF 600 Series

Housing No.	A	B	P	G	E		E1	H	K Static Oil Level	L	Bolts (No. Req'd)	Wt.
	In.	In.	In.	In.	Max In.	Min In.	In.	In.	In.	In.	In	lbs.*
SDAF 616	4-1/4	14-1/4	5-1/2	1-3/4	12-5/8	10-5/8	3-1/4	8-1/4	1-3/4	6-3/8	(4)--5/8	49
SDAF 617	4-1/2	15-1/4	6	1-7/8	13-1/8	11-5/8	3-3/8	8-15/16	1-13/16	6-3/4	(4)--3/4	64
SDAF 618	4-3/4	15-1/2	6-1/8	2	13-1/2	12	3-5/8	9-7/16	2	6-7/8	(4)--3/4	72
SDAF 620	5-1/4	16-1/2	6-7/8	2-1/4	14-1/2	13-1/4	4-1/8	10-1/2	2-1/8	7-3/8	(4)--7/8	110
SDAF 622	6	18-3/8	7-1/2	2-3/8	16	14-5/8	4-1/2	11-7/8	2-1/2	8	(4)--1	145
SDAF 624	6-5/16	21-1/4	7-7/8	2-1/2	18-1/4	17	4-3/4	12-13/16	2-9/16	8-3/8	(4)--1-1/8	170
SDAF 626	6-11/16	22	8-1/4	2-1/2	19-1/4	17-3/8	5	13-11/16	2-5/8	8-3/4	(4)--1-1/8	193
SDAF 628	7-1/16	24-3/4	9	2-1/2	21-5/8	19-3/8	5-1/2	14-1/4	2-11/16	9-3/8	(4)--1-1/4	228
SDAF 630	7-1/2	26-3/4	9-3/8	2-3/4	23-5/8	20-7/8	5-7/8	15-3/16	2-7/8	9-3/4	(4)--1-1/4	294
SDAF 632	7-7/8	27-5/8	10	3	23-1/2	21-1/2	6-1/4	16-1/4	2-15/16	10-5/8	(4)--1-3/8	350
SDAF 634	8-1/4	28-3/4	10-1/2	3-1/4	25	23	6-3/4	17-1/8	3-1/16	11-1/8	(4)--1-3/8	390
SDAF 636	8-7/8	30-1/2	10-3/4	3-1/4	26-3/8	24-1/8	6-7/8	17-15/16	3-3/8	11-3/8	(4)--1-1/2	404
SDAF 638	9-1/2	32	11-1/4	3-1/2	27-7/8	25-5/8	7-1/4	19-1/4	3-11/16	11-7/8	(4)--1-1/2	486
SDAF 640	9-7/8	33-1/2	11-3/4	3-1/2	29-1/4	26-5/8	7-5/8	19-15/16	3-3/4	12-3/8	(4)--1-5/8	560

*Weights are approximate

Application Data

Spherical Roller Bearings – page 74

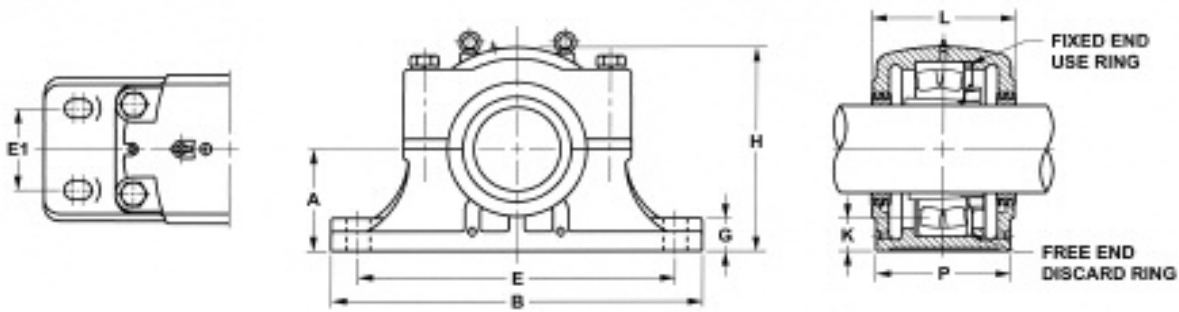

Shaft Diameter S-1 in	Complete Unit Number	Housing Only ^(a)	Bearing Number	Adapter Locknut and Lockwasher	Labyrinth Seal Ring (2 required)	Fixing Ring ^(b) (1 required)	End Cover ^(c)
2-11/16	SDAF 22616	SDAF 616	22316 K	SNW116 X 2-11/16	LER 44	FR170X10	EPR 08
2-15/16	SDAF 22617	SDAF 617	22317 K	SNW117 X 2-15/16	LER 59	FR180X10	EPR 10
3-3/16	SDAF 22618	SDAF 618	22318 K	SNW118 X 3-3/16	LER 69	FR190X10	EPR 11
3-7/16	SDAF 22620	SDAF 620	22320 K	SNW120 X 3-7/16	LER 75	FR218X10	EPR 11
3-15/16	SDAF 22622	SDAF 622	22322 K	SNW122 X 3-15/16	LER 93	FR240X10	EPR 13
4-3/16	SDAF 22624	SDAF 624	22324 K	SNW124 X 4-3/16	LER 113	FR260X10	EPR 14
4-7/16	SDAF 22626	SDAF 626	22326 K	SNW126 X 4-7/16	LER 117	FR280X10	EPR 15
4-15/16	SDAF 22628	SDAF 628	22328 K	SNW128 X 4-15/16	LER 122	FR300X10	EPR 27
5-3/16	SDAF 22630	SDAF 630	22330 K	SNW130 X 5-3/16	LER 125	FR320X10	EPR 16
5-7/16	SDAF 22632	SDAF 632	22332 K	SNW132 X 5-7/16	LER 211	FR340X10	EPR 17
5-15/16	SDAF 22634	SDAF 634	22334 K	SNW134 X 5-15/16	LER 215	FR360X10	EPR 19
6-7/16	SDAF 22636	SDAF 636	22336 K	SNW136 X 6-7/16	LER 220	SR-0-36	EPR 26
6-15/16	SDAF 22638	SDAF 638	22338 K	SNW138 X 6-15/16	LER 224	FR400X10	EPR 21
7-3/16	SDAF 22640	SDAF 640	22340 K	SNW140 X 7-3/16	LER 228	FR420X10	EPR 22

Note: Housings available in cast iron (SDAF), Ductile (SDAFD) or cast steel (SDAFS).

Taconite (TER) and LOR seals with O-rings are also available

(a) "Housing Only" includes - cap, base, cap bolts, labyrinth seals and fixing rings

(b) Fixing Ring is used for fixed block only; do not use for float mounting

(c) End Cover is optional

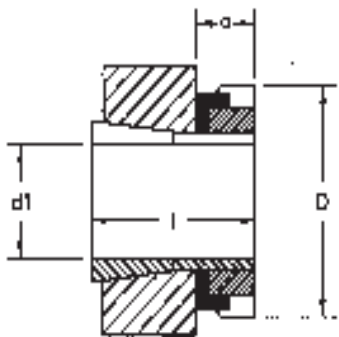

Inch Adapter Sleeves

With Nut and Washer

For 222 Series Bearings

(also used with 12, 13, and 22 Series)

Part No. (Bore)	Weight Lbs.	Dimension in Inches				Lock Nut	Lock Washer
		d1	l	D	c		
SNW 05 X 3/4	0.2	3/4	1.27	1.6	0.46	N 05	W 05
SNW 05 X 11/16	0.3	11/16	1.27	1.6	0.46	N 05	W 05
SNW 06 X 15/16	0.2	15/16	1.35	1.8	0.46	N 06	W 06
SNW 06 X 1	0.2	1	1.35	1.8	0.46	N 06	W 06
SNW 07 X 1-1/16	0.4	1-1/16	1.46	2.1	0.48	N 07	W 07
SNW 07 X 1-1/4	0.3	1-1/4	1.46	2.1	0.48	N 07	W 07
SNW 07 X 1-1/8	0.3	1-1/8	1.46	2.1	0.48	N 07	W 07
SNW 07 X 1-3/16	0.3	1-3/16	1.46	2.1	0.48	N 07	W 07
SNW 08 X 1-1/4	0.4	1-1/4	1.50	2.3	0.50	N 08	W 08
SNW 08 X 1-3/8	0.4	1-3/8	1.50	2.3	0.50	N 08	W 08
SNW 08 X 1-5/16	0.4	1-5/16	1.50	2.3	0.50	N 08	W 08
SNW 09 X 1-3/8	0.6	1-3/8	1.58	2.5	0.50	N 09	W 09
SNW 09 X 1-1/2	0.6	1-1/2	1.58	2.5	0.50	N 09	W 09
SNW 09 X 1-7/16	0.6	1-7/16	1.58	2.5	0.50	N 09	W 09
SNW 10 X 1-11/16	0.7	1-11/16	1.77	2.7	0.56	N 10	W 10
SNW 10 X 1-3/4	0.7	1-3/4	1.77	2.7	0.56	N 10	W 10
SNW 10 X 1-5/8	0.7	1-5/8	1.77	2.7	0.56	N 10	W 10
SNW 11 X 1-13/16	0.8	1-13/16	1.85	3.0	0.56	N 11	W 11
SNW 11 X 1-3/4	0.8	1-3/4	1.85	3.0	0.56	N 11	W 11
SNW 11 X 1-7/8	0.8	1-7/8	1.85	3.0	0.56	N 11	W 11
SNW 11 X 1-15/16	0.9	1-15/16	1.85	3.0	0.56	N 11	W 11
SNW 11 X 2	0.9	2	1.85	3.0	0.56	N 11	W 11
SNW 13 X 2	1.0	2	2.10	3.4	0.63	N 13	W 13
SNW 13 X 2-1/4	1.4	2-1/4	2.10	3.4	0.63	N 13	W 13
SNW 13 X 2-3/16	1.4	2-3/16	2.10	3.4	0.63	N 13	W 13
SNW 13 X 2-5/16	1.3	2-5/16	2.10	3.4	0.63	N 13	W 13
SNW 15 X 2-1/2	2.3	2-1/2	2.30	3.9	0.67	AN 15	W 15
SNW 15 X 2-3/8	2.4	2-3/8	2.30	3.9	0.67	AN 15	W 15
SNW 15 X 2-5/8	2.2	2-5/8	2.30	3.9	0.67	AN 15	W 15
SNW 15 X 2-7/16	2.2	2-7/16	2.30	3.9	0.67	AN 15	W 15
SNW 16 X 2-11/16	2.4	2-11/16	2.38	4.2	0.67	AN 16	W 16
SNW 16 X 2-3/4	2.4	2-3/4	2.38	4.2	0.67	AN 16	W 16
SNW 17 X 2-15/16	2.9	2-15/16	2.49	4.4	0.70	AN 17	W 17
SNW 17 X 3	2.9	3	2.49	4.4	0.70	AN 17	W 17
SNW 18 X 3-1/4	4.0	3-1/4	2.49	4.7	0.78	AN 18	W 18
SNW 18 X 3	4.0	3	2.65	4.7	0.78	AN 18	W 18
SNW 20 X 3-1/2	4.0	3-1/2	2.87	5.2	0.84	AN 20	W 20
SNW 20 X 3-7/16	4.0	3-7/16	2.87	5.2	0.84	AN 20	W 20
SNW 22 X 3-11/16	4.9	3-11/16	3.21	5.7	0.91	AN 22	W 22
SNW 22 X 3-15/16	4.8	3-15/16	3.21	5.7	0.91	AN 22	W 22
SNW 22 X 4	4.8	4	3.21	5.7	0.91	AN 22	W 22
SNW 24 X 4-1/4	6.2	4-1/4	3.47	6.1	0.94	AN 24	W 22
SNW 24 X 4-3/16	6.2	4-3/16	3.47	6.1	0.94	AN 24	W 24
SNW 26 X 4-7/16	9.7	4-7/16	3.76	6.8	1.00	AN 26	W 26
SNW 26 X 4-1/2	9.7	4-1/2	3.76	6.8	1.00	AN 26	W 26
SNW 28 X 4-15/16	10.5	4-15/16	3.98	7.1	1.06	AN 28	W 28
SNW 28 X 4-7/8	10.5	4-7/8	3.98	7.1	1.06	AN 28	W 28
SNW 28 X 5	10.5	5	3.98	7.1	1.06	AN 28	W 28
SNW 30 X 5-1/4	16.0	5-1/4	4.24	7.7	1.13	AN 30	W 30
SNW 30 X 5-3/16	16.0	5-3/16	4.24	7.7	1.13	AN 30	W 30
SNW 32 X 5-1/2	16.0	5-1/2	4.58	8.1	1.19	AN 32	W 32
NW 32 X 5-7/16	16.0	5-7/16	4.58	8.1	1.19	AN 32	W 32
SNW 32 X 5-3/4	16.0	5-3/4	4.58	8.1	1.19	AN 32	W 32
SNW 34 X 5-15/16	19.5	5-15/16	4.85	8.7	1.22	AN 34	W 34
SNW 34 X 6	19.5	6	4.85	8.7	1.22	AN 34	W 34
SNW 36 X 6-7/16	20.5	6-7/16	5.04	9.1	1.25	AN 36	W 36
SNW 36 X 6-1/2	20.5	6-1/2	5.04	9.1	1.25	AN 36	W 36
SNW 38 X 6-15/16	23.5	6-15/16	5.26	9.5	1.28	AN 38	W 38
SNW 38 X 7	23.5	7	5.26	9.5	1.28	AN 38	W 38
SNW 40 X 7-3/16	30.5	7-3/16	5.48	9.8	1.34	AN 40	W 40
SNW 40 X 7-3/8	30.5	7-3/8	5.48	9.8	1.34	AN 40	W 40
SNW 44 X 7-1/2	32.5	7-1/2	5.90	11.0	1.41	N 44	W 44
SNW 44 X 7-7/8	32.5	7-7/8	5.90	11.0	1.41	N 44	W 44
SNW 44 X 7-15/16	32.5	7-15/16	5.90	11.0	1.41	N 44	W 44
SNW 44 X 8	32.5	8	5.90	11.0	1.41	N 44	W 44

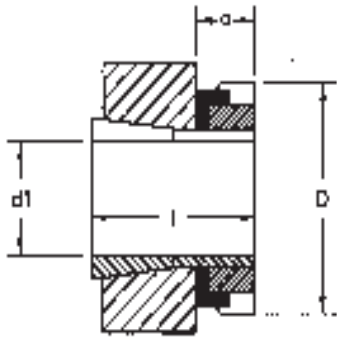

Inch Adapter Sleeves

With Nut and Washer

For 223 and 232 Series Bearings

Part No. (Bore)	Weight Lbs.	Dimension in Inches				Lock Nut	Lock Washer
		d1	l	D	c		
SNW 109 X 1-7/16	0.7	1-7/16	2.13	2.53	0.50	N 09	W 09
SNW 109 X 1-1/2	0.7	1-1/2	2.13	2.53	0.50	N 09	W 09
SNW 110 X 1-11/16	0.9	1-11/16	2.39	2.69	0.56	N 10	W 10
SNW 110 X 1-3/4	0.9	1-3/4	2.39	2.69	0.56	N 10	W 10
SNW 111 X 1-7/8	0.9	1-7/8	2.52	2.97	0.56	N 11	W 11
SNW 111 X 1-15/16	0.9	1-15/16	2.52	2.97	0.56	N 11	W 11
SNW 111 X 2	0.9	2	2.52	2.97	0.56	N 11	W 11
SNW 113 X 2-1/4	1.8	2-1/4	2.77	3.38	0.63	N 13	W 13
SNW 113 X 2-3/16	1.8	2-3/16	2.77	3.38	0.63	N 13	W 13
SNW 115 X 2-3/8	3.0	2-3/8	3.08	3.88	0.70	AN 15	W 15
SNW 115 X 2-7/16	3.0	2-7/16	3.08	3.88	0.70	AN 15	W 15
SNW 115 X 2-1/2	3.0	2-1/2	3.08	3.88	0.70	AN 15	W 15
SNW 116 X 2-11/16	3.2	2-11/16	3.20	4.16	0.67	AN 16	W 16
SNW 116 X 2-3/4	3.2	2-3/4	3.20	4.16	0.67	AN 16	W 16
SNW 117 X 2-15/16	3.4	2-15/16	3.31	4.41	0.70	AN 17	W 17
SNW 117 X 3	3.4	3	3.31	4.41	0.70	AN 17	W 17
SNW 118 X 3-3/16	4.0	3-3/16	3.55	4.66	0.78	AN 18	W 18
SNW 118 X 3-1/4	4.0	3-1/4	3.55	4.66	0.78	AN 18	W 18
SNW 120 X 3-7/16	6.3	3-7/16	3.97	5.19	0.84	AN 20	W 20
SNW 120 X 3-1/2	6.3	3-1/2	3.97	5.19	0.84	AN 20	W 20
SNW 122 X 3-11/16	6.5	3-11/16	4.35	5.72	0.91	AN 22	W 22
SNW 122 X 3-15/16	6.5	3-15/16	4.35	5.72	0.91	AN 22	W 22
SNW 122 X 4	6.5	4	4.35	5.72	0.91	AN 22	W 22
SNW 124 X 4-3/16	7.8	4-3/16	4.65	6.13	0.94	AN 24	W 24
SNW 124 X 4-1/4	7.8	4-1/4	4.65	6.13	0.94	AN 24	W 24
SNW 126 X 4-7/16	12.5	4-7/16	4.98	6.75	1.00	AN 26	W 26
SNW 126 X 4-1/2	12.5	4-1/2	4.98	6.75	1.00	AN 26	W 26
SNW 128 X 4-15/16	13.0	4-15/16	5.32	7.09	1.06	AN 28	W 28
SNW 128 X 5	13.0	5	5.32	7.09	1.06	AN 28	W 28
SNW 130 X 5-3/16	18.0	5-3/16	5.62	7.69	1.13	AN 30	W 30
SNW 130 X 5-1/4	18.0	5-1/4	5.62	7.69	1.13	AN 30	W 30
SNW 132 X 5-7/16	18.0	5-7/16	5.92	8.06	1.19	AN 32	W 32
SNW 134 X 5-15/16	21.0	5-15/16	6.19	8.66	1.22	AN 34	W 34
SNW 134 X 6	21.0	6	6.19	8.66	1.22	AN 34	W 34
SNW 136 X 6-7/16	20.5	6-7/16	6.46	9.06	1.25	AN 36	W 36
SNW 136 X 6-1/2	20.5	6-1/2	6.46	9.06	1.25	AN 36	W 36
SNW 138 X 6-15/16	28.0	6-15/16	6.76	9.47	1.28	AN 38	W 38
SNW 138 X 7	28.0	7	6.76	9.47	1.28	AN 38	W 38
SNW 140 X 7-3/16	35.5	7-3/16	7.10	9.84	1.34	AN 40	W 40
SNW 144 X 7-15/16	46.5	7-15/16	7.29	11.00	1.41	N 44	W 44
SNW 144 X 8	46.5	8	7.29	11.00	1.41	N 44	W 44

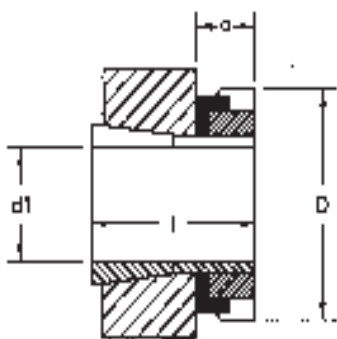

Inch Adapter Sleeves

With Nut and Washer

For 230 Series Bearings

Part No. (Bore)	Weight Lbs.	Dimension in Inches				Lock Nut	Lock Washer
		d_1	l	D	c		
SNW 3024 X 4-3/16	6.2	4-3/16	2.95	5.69	0.94	AN 24	W 24
SNW 3026 X 4-7/16	7.5	4-7/16	3.24	6.13	1.00	AN 26	W 26
SNW 3026 X 4-1/2	7.5	4-1/2	3.24	6.13	1.00	AN 26	W 26
SNW 3028 X 4-15/16	8.5	4-15/16	3.34	6.50	1.06	AN 28	W 28
SNW 3028 X 5	8.5	5	3.34	6.50	1.06	AN 28	W 28
SNW 3030 X 5-3/16	9.8	5-3/16	3.49	7.13	1.13	AN 30	W 30
SNW 3030 X 5-1/4	9.8	5-1/4	3.49	7.13	1.13	AN 30	W 30
SNW 3032 X 5-7/16	12.0	5-7/16	3.71	7.50	1.19	AN 32	W 32
SNW 3034 X 5-15/16	13.5	5-15/16	4.02	7.88	1.22	AN 34	W 34
SNW 3034 X 6	13.5	6	4.02	7.88	1.22	AN 34	W 34
SNW 3036 X 6-7/16	15.0	6-7/16	4.34	8.25	1.25	AN 36	W 36
SNW 3036 X 6-1/2	15.0	6-1/2	4.34	8.25	1.25	AN 36	W 36
SNW 3038 X 6-15/16	17.0	6-15/16	4.41	8.69	1.28	AN 38	W 38
SNW 3038 X 7	17.0	7	4.41	8.69	1.28	AN 38	W 38
SNW 3040 X 7-3/16	19.5	7-3/16	4.75	9.44	1.34	AN 40	W 40
SNW 3044 X 7-15/16	24.5	7-15/16	5.13	10.25	1.38	N 44	W 44
SNW 3044 X 8	24.5	8	5.13	10.25	1.38	N 44	W 44
SNP 3048 X 8-7/16	31.0	8-7/16	5.43	11.44	1.70	N 048	P 48
SNP 3048 X 8-1/2	31.0	8-1/2	5.43	11.44	1.70	N 048	P 48
SNP 3048 X 8-15/16	32.0	8-15/16	5.43	11.44	1.70	N 048	P 48
SNP 3048 X 9	32.0	9	5.43	11.44	1.70	N 048	P 48
SNP 3052 X 9-7/16	41.0	9-7/16	6.02	12.19	1.77	N 052	P 52
SNP 3052 X 9-1/2	40.0	9-1/2	6.02	12.19	1.77	N 052	P 52
SNP 3056 X 9-15/16	47.0	9-15/16	6.19	13.00	1.86	N 056	P 56
SNP 3056 X 10	46.0	10	6.19	13.00	1.86	N 056	P 56
SNP 3056 X 10-7/16	45.0	10-7/16	6.19	13.00	1.86	N 056	P 56
SNP 3056 X 10-1/2	45.0	10-1/2	6.19	13.00	1.86	N 056	P 56
SNP 3060 X 10-15/16	59.0	10-15/16	6.73	14.19	1.97	N 060	P 60
SNP 3060 X 11	59.0	11	6.73	14.19	1.97	N 060	P 60
SNP 3064 X 11-1/2	66.0	11-1/2	6.95	15.00	2.06	N 064	P 64
SNP 3064 X 12	66.0	12	6.95	15.00	2.06	N 064	P 64
SNP 3068 X 12-7/16	78.0	12-7/16	7.54	15.75	2.19	N 068	P 68
SNP 3068 X 12-1/2	78.0	12-1/2	7.54	15.75	2.19	N 068	P 68
SNP 3072 X 13-7/16	86.0	13-7/16	7.58	16.50	2.19	N 072	P 72
SNP 3076 X 13-15/16	95.0	13-15/16	7.74	17.75	2.41	N 076	P 76
SNP 3076 X 14	95.0	14	7.74	17.75	2.41	N 076	P 76
SNP 3080 X 15	100.0	15	8.41	18.50	2.56	N 080	P 80
SNP 3084 X 15-3/4	105.0	15-3/4	8.50	19.31	2.56	N 084	P 84
SNP 3088 X 16	143.0	16	8.98	20.47	2.36	N 088	P 88
SNP 3088 X 16-1/2	143.0	16-1/2	8.98	20.47	2.36	N 088	P 88
SNP 3092 X 17	153.0	17	9.21	21.26	2.36	N 092	P 92
SNP 3096 X 18	161.0	18	9.33	22.05	2.36	N 096	P 96
SNP 3500 X 18-1/2	180.0	18-1/2	9.72	22.83	2.68	N 500	P 500

Inch Lock Nuts

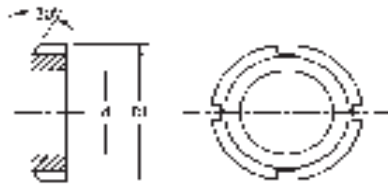

Part No.	Thread per inch	d in.	D1 in.
N 00	32	0.39	0.76
N 01	32	0.47	0.88
N 02	32	0.59	1.01
N 03	32	0.66	1.13
N 04	32	0.78	1.38
N 05	32	0.97	1.57
N 06	18	1.17	1.76
N 07	18	1.38	2.07
N 08	18	1.56	2.26
N 09	18	1.77	2.54
N 10	18	1.97	2.69
N 11	18	2.16	2.97
N 12	18	2.36	3.16
N 13	18	2.55	3.38
N 14	18	2.75	3.63
AN 15	12	2.93	3.88
AN 16	12	3.14	4.16
AN 17	12	3.34	4.41
AN 18	12	3.53	4.66
AN 19	12	3.73	4.94
AN 20	12	3.92	5.19
AN 21	12	4.12	5.44
AN 22	12	4.33	5.72
AN 24	12	4.72	6.13
AN 26	12	5.11	6.76
AN 28	12	5.50	7.10
AN 30	12	5.89	7.69
AN 32	8	6.28	8.07
AN 34	8	6.66	8.66
AN 36	8	7.07	9.07
AN 38	8	7.47	9.47
AN 40	8	7.85	9.85
N 44	8	8.63	11.01

Inch Lock Washers

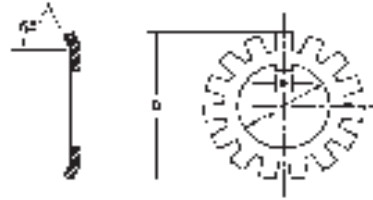

Part No.	d in.	D1 in.	e in.
W 00	0.41	0.88	0.12
W 01	0.48	1.02	0.12
W 02	0.60	1.16	0.12
W 03	0.68	1.33	0.12
W 04	0.80	1.53	0.18
W 05	0.99	1.72	0.18
W 06	1.19	1.92	0.18
W 07	1.40	2.25	0.18
W 08	1.58	2.47	0.29
W 09	1.79	2.73	0.29
W 10	1.99	2.92	0.29
W 11	2.18	3.11	0.29
W 12	2.40	3.34	0.29
W 13	2.59	3.58	0.29
W 14	2.79	3.83	0.29
W 15	2.97	4.11	0.29
W 16	3.18	4.38	0.35
W 17	3.40	4.63	0.35
W 18	3.58	4.94	0.35
W 19	3.80	5.22	0.35
W 20	3.99	5.50	0.35
W 21	4.19	5.70	0.35
W 22	4.40	6.06	0.35
W 24	4.80	6.47	0.35
W 26	5.19	7.03	0.44
W 28	5.58	7.44	0.59
W 30	5.98	8.06	0.59
W 32	6.39	8.44	0.59
W 34	6.76	9.06	0.72
W 36	7.17	9.44	0.72
W 38	7.58	9.88	0.72
W 40	7.98	10.31	0.84
W 44	8.70	11.44	0.94

Table of Contents

Super Precision Machine Tool Bearings

Introduction
Ball Bearings
Cylindrical Roller Bearings
Spherical Roller Bearings
Tapered Roller Bearings
Thrust Bearings
Split Pillow Blocks
Super Precision Bearings
Linear Motion
Rolling Mill Bearings
Engineering Section

INTRODUCTION

About NSK Super Precision Machine Tool Bearings	183
---	-----

NOMENCLATURE/INTERCHANGE

Super Precision Angular Contact	184
Super Precision Cylindrical Roller	186
Angular Contact Thrust Ball Bearings . . .	187
Ball Screw Support Bearings	188

APPLICATION

Super Precision Angular Contact	189
Super Precision Cylindrical Roller	189
Ball Screw Support Bearings	189

BEARING TABLES

Series 7000C	190
Series 7000A5	192
Series 7200C	194
Series 7200A5	196
Series 7900C	198
Series 7900A5	200
Series BNC	202
Series BNR	206
Series BGR	210
Series BAR/BTR	214
Series N1000	218
Series NN3000	220
Series NN3900	222
Ball Screw Support Bearings	224

Introduction

ABOUT NSK SUPER PRECISION BEARINGS

- Super Precision Angular Contact Bearings
- High Speed Super Precision Angular Contact Bearings
- Super Precision Angular Contact Thrust Bearings
- Super Precision Cylindrical Roller Bearings
- Ball Screw Support Bearings

NSK has developed new methods of manufacturing to produce several series of bearings that meet the ever-increasing needs for higher speeds and greater precision in bearing applications. These Super Precision Bearings include angular contact bearings, precision cylindrical roller bearings and ball screw support bearings.

Super Precision Angular Contact bearings are specifically designed for rigid, high-speed, high-precision machine tool spindles. Their state-of-the-art preload control assures consistent high performance.

High Speed Super Precision Angular Contact bearings are now available due to NSK's new optimized design, under the ROBUST name. Allowing increased speeds and improved performance, these series are available in application specific designs for machining center applications (BNR), and high speed grinding applications (BGR) – both allowing customers to push the limits of existing speeds. In addition, NSK offers a standard small ball design (BNC) offering higher speeds than the standard super precision angular contact, at less of a cost premium than our robust design.

Super Precision Angular Contact Thrust bearings are designed to work in tandem with high speed super precision cylindrical roller bearings where high speed, and high rigidity are required. Offered in a 30° and 40° series, this offering allows flexibility for meeting the rigidity requirements seen in many machine tool applications.

Super Precision Cylindrical roller bearings are designed to specifically handle large radial loads in high speed applications. They are available in a variety of designs, including double row and single row options, to suit various applications. In addition, a standard lube groove and hole feature is available along with tapered and non-tapered bores. When combined with Super Precision Angular Contact Thrust bearings, the Super Precision Cylindrical meets the high rigidity requirements of many machine tool spindle applications.

Ball Screw Support bearings are designed specifically to provide maximum axial rigidity and improved feeding accuracy for use with precision ball screws. They are high accuracy angular contact thrust bearings, which are superior to combinations of standard angular contact bearings or arrangements of radial and thrust bearings for ball screw applications. Both Metric and Inch series are available.

Nomenclature — Super Precision Angular Contact

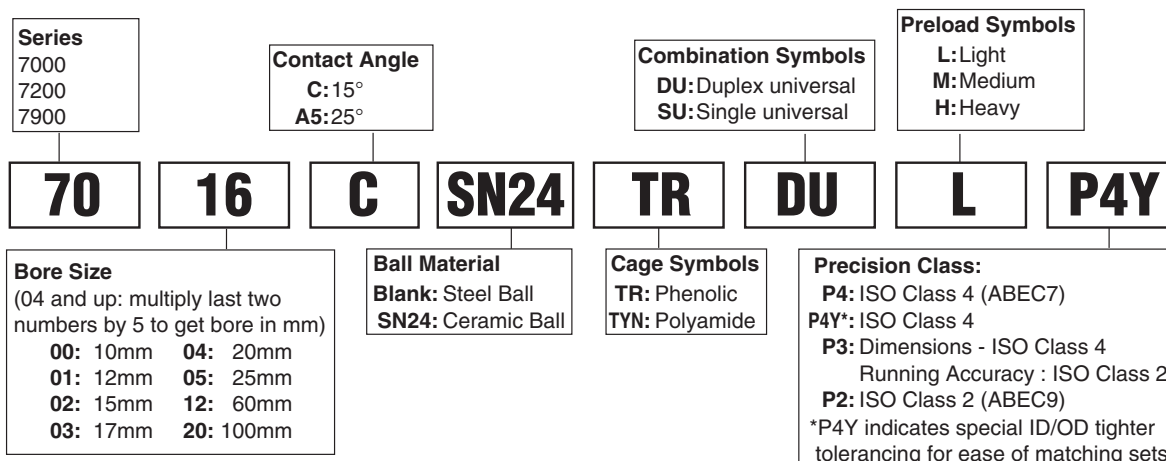

Please refer to the bearing tables for exact part number options.

Interchange — Super Precision Angular Contact

DESCRIPTION		INTERCHANGE				
		NSK	SKF	TORR/FAF	BARDEN	NTN
Part Number	EXTRA LIGHT SERIES	70xx	70xx	MM91xxWI	1xx	70xx
	LIGHT SERIES	72xx	72xx	MM2xxWI	2xx	72xx
	ULTRA LIGHT SERIES	79xx	79xx	MM93xxWI	19xx	79xx
	25° CONTACT ANGLE	A5	ACD	*3	*2	--
	15° CONTACT ANGLE	C	CD	*2	BLANK	C
Suffix	POLYAMIDE CAGE	TY	BLANK	BLANK	--	T2
	PHENOLIC CAGE	TR	--	CR	BLANK	T1
	DUPLEX UNIVERSAL	DU	DG	DU	D	GD2
	SINGLE UNIVERSAL	SU	G	SU	BLANK	G
	LIGHT PRELOAD	L	A	L	L	GN
	MEDIUM PRELOAD	M	B	M	M	GM
	HEAVY PRELOAD	H	C	H	H	GH
	ABEC 7 PRECISION	P4, PA7	P4,PA7	MM	BLANK	P4
	ABEC 5 PRECISION	P5, PA5	P5,PA5	V	--	P5
ABEC 9 PRECISION	P2, PA9	P2,PA9	MMX	ABEC 9	P2	

*Prefix

The competitive manufacturers are provided for a convenient source of unit substitution. They can be considered interchangeable in most instances, but for special applications, please consult NSK Engineering. NSK assumes no liability with respect to errors or omissions.

Nomenclature — High Speed Super Precision Angular Contact Ball Bearings

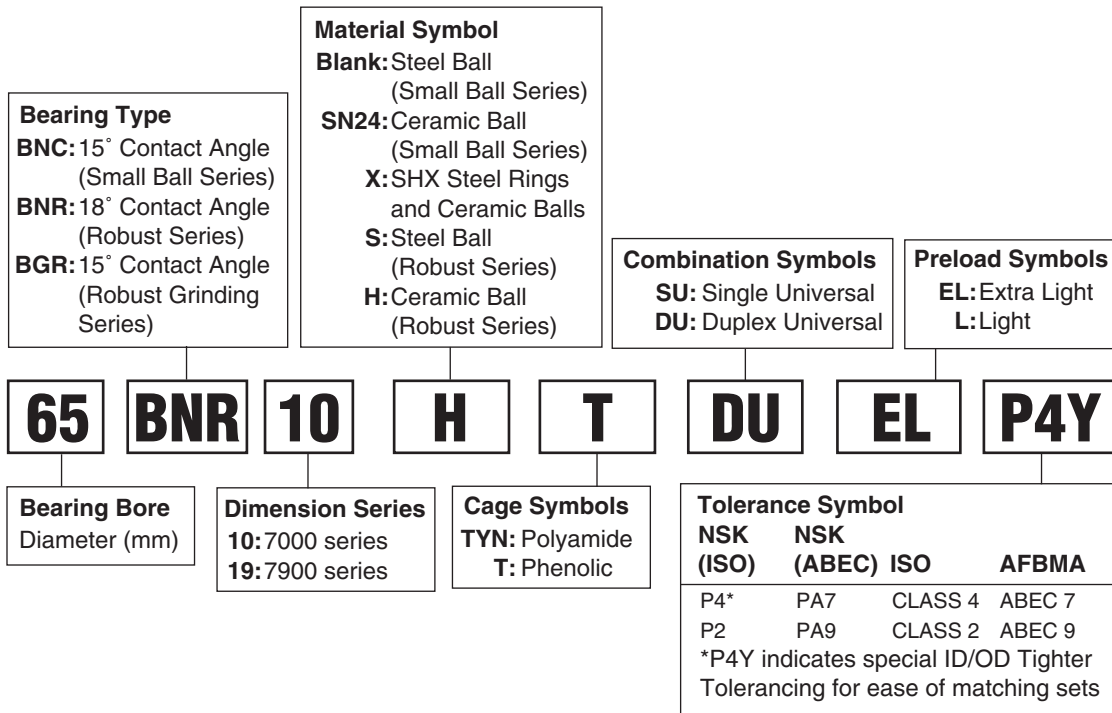

Interchange — Super Precision Angular Contact

DESCRIPTION		INTERCHANGE			
		NSK	SKF	FAG	NTN
Part Number	SMALL BALL SERIES	xxBNC	70xxCE	MMV99	ZSBxx
	ROBUST HIGH SPEED SERIES	xxBNR	--	MMVxxHX	--
	ROBUST HIGH SPEED GRINDING SERIES	xxBGR	--	--	xxBX48
Suffix	POLYAMIDE CAGE	TYN	BLANK	BLANK	--
	PHENOLIC CAGE	T	--	CR	BLANK
	DUPLEX UNIVERSAL	DU	DG	DU	D
	SINGLE UNIVERSAL	SU	G	SU	BLANK
	EXTRA LIGHT PRELOAD	EL	--	--	--
	LIGHT PRELOAD	L	A	L	L
	CERAMIC BALLS	SN24, H	HC	C	C
	ABEC 7 PRECISION	P4	P4, PA7	MM	BLANK
	ABEC 9 PRECISION	P2	P2, PA9	MMX2	ABEC 9

Introduction

Ball Bearings

Cylindrical Roller Bearings

Spherical Roller Bearings

Tapered Roller Bearings

Thrust Bearings

Split Pillow Blocks

Super Precision Bearings

Linear Motion

Rolling Mill Bearings

Engineering Section

Nomenclature — Super Precision Cylindrical Roller Bearings Double Row — Super Precision Cylindrical Roller Bearings

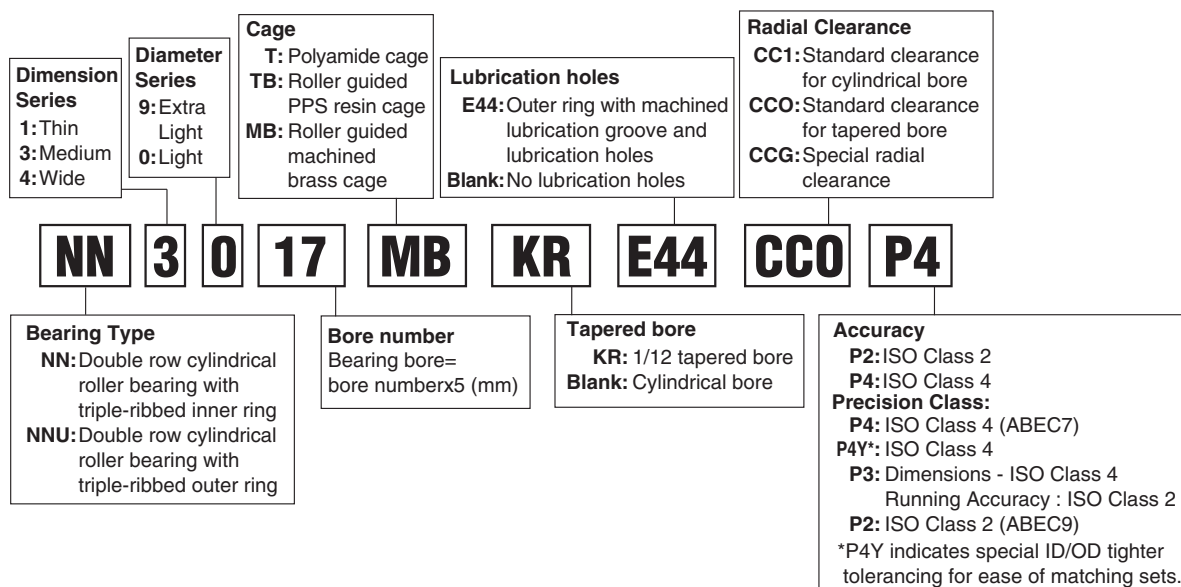

Single Row — Super Precision Cylindrical Roller Bearings

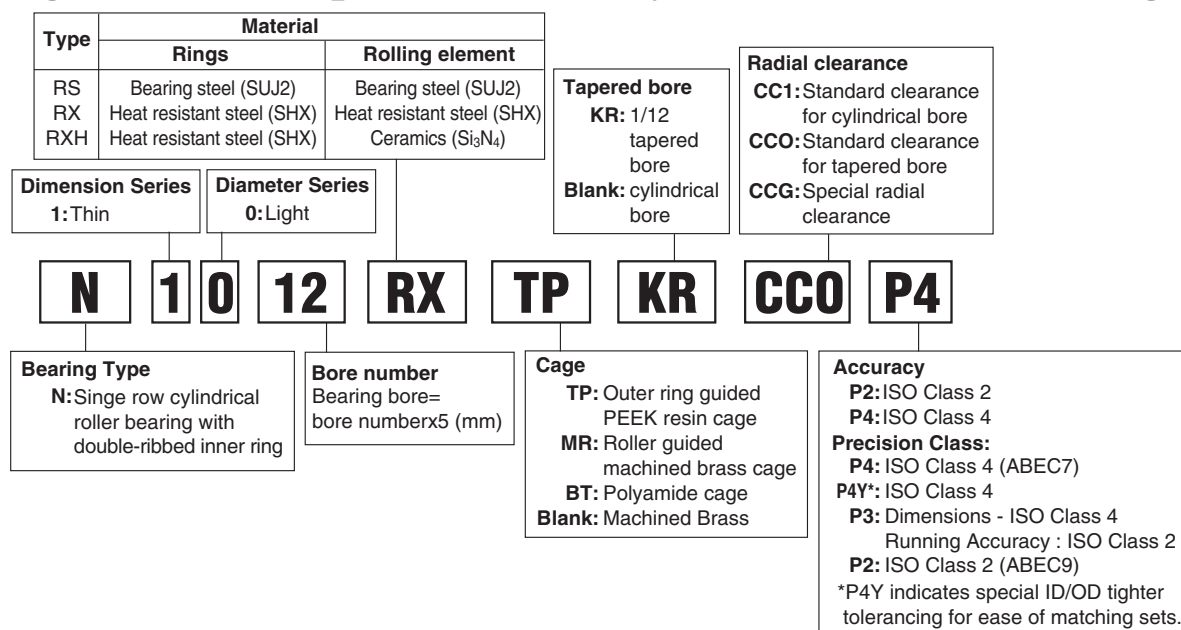

Interchange — Super Precision Cylindrical Roller Bearings

DESCRIPTION		INTERCHANGE			
		NSK	SKF	FAG	NTN
Part Number	DOUBLE ROW, NO FLANGES OUTER RING	NN30xx	NN30xx	NN30xx	NN30xx
	DOUBLE ROW, NO FLANGES OUTER RING	NN39xx	--	--	--
	DOUBLE ROW, NO FLANGES INNER RING	NNU49xx	NNU49xxB	NNU49xx	NNU49xx
	SINGLE ROW, NO FLANGES OUTER RING	N10xx	N10xx	N10xx	N10xx
Suffix	BRASS, MACHINED TWO PIECE, ROLLER GUIDED	MB	--	M	G1
	BRASS, MACHINED ONE PIECE, INNER RING GUIDED	BLANK	M	--	--
	NYLON, MOLDED, ROLLER GUIDED	T	TN	--	--
	SPECIAL PRECISION 1:12 TAPER BORE	KR	UPK	K	K
	LUBE GROOVE WITH HOLES, OUTER RING ONLY	E44	W33	S	--
	PLAIN O.D.	BLANK	W	--	BLANK
	MATCHED CLEARANCE, RINGS NOT TO BE MIXED TOLERANCE CLASS P4	CCx P4	Cx SP	Cx SP	CxNA P4

The competitive manufacturers are provided for a convenient source of unit substitution. They can be considered interchangeable in most instances, but for special applications, please consult NSK Engineering. NSK assumes no liability with respect to errors or omissions.

Nomenclature — Angular Contact Thrust Ball Bearings

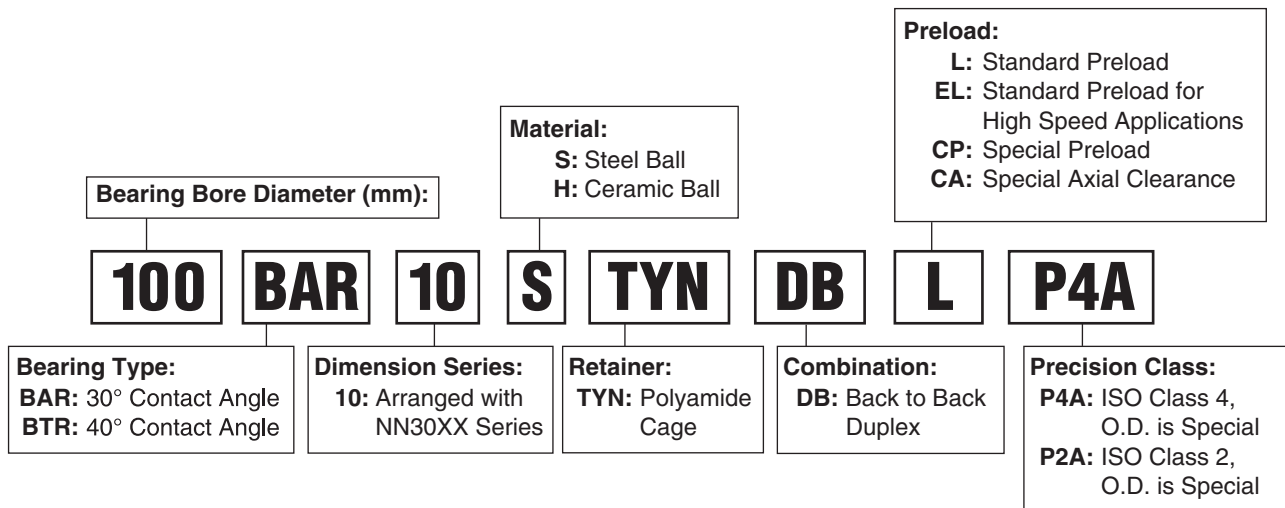

Interchange — Angular Contact Thrust Ball Bearings

DESCRIPTION	INTERCHANGE		
	NSK	SKF	NTN
BAR Series (30°) BTR Series (40°)	80BAR10 80BTR10	BTM80A/DB() BTM80B/DB()	HTA016ADB() HTA016DB()

Undersigned digits (80) vary with bore diameter.
 () indicates clearance.

Introduction

Ball Bearings

Cylindrical Roller Bearings

Spherical Roller Bearings

Tapered Roller Bearings

Thrust Bearings

Split Pillow Blocks

Super Precision Bearings

Linear Motion

Rolling Mill Bearings

Engineering Section

Nomenclature — Ball Screw Support Bearings

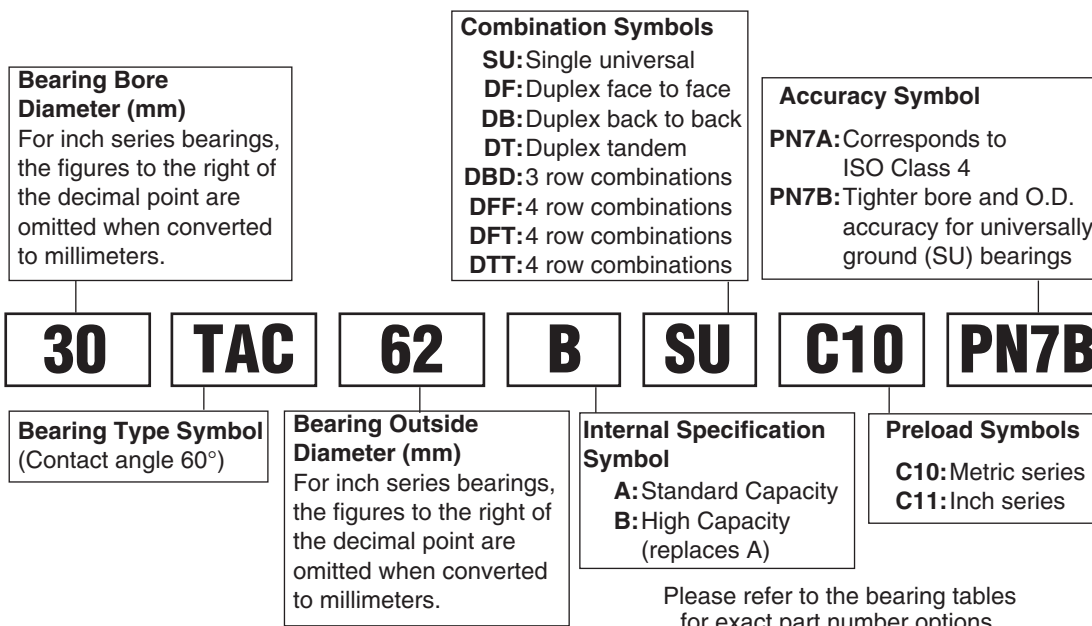

Interchange — Ball Screw Support Bearings

DESCRIPTION		INTERCHANGE				
		NSK	SKF	TORR/FAF	MRC	NTN
Part No.	METRIC TYPE	xxTACxxx	BDAB6342xx	MMxxBSxxx	--	BSTxxXxx
	INCH TYPE	xxTACxxx	BDAB6342xx	MM93xxWI xH	Jxxx	--
Suffix	INTERNAL SPECIFICATIONS (Standard Capacity)	A	--	--	--	X
	INTERNAL SPECIFICATIONS (High Capacity)	B	A	--	--	-1
	SINGLE UNIVERSAL	SU	--	SU	DS	BLANK
	DUPLEX UNIVERSAL	DU	DG	DU	DU	--
	DUPLEX FACE TO FACE	DF	DF	DU	DF	DF
	DUPLEX BACK TO BACK	DB	DB	DU	DB	DB
	DUPLEX TANDEM	DT	DT	DU	DT	DT
	QUAD SET \\\	DFF	QFC	QU	--	DTFT
	QUAD SET \\\	DFT	QFT	QU	DFDT	--
	QUAD SET /\	DBB	QBC	QU	--	--
	QUAD SET /\	DBT	QBT	QU	--	DTBT
	QUAD SET /\	DTT	QT	QU	--	--
	METRIC SERIES PRELOAD	C10	BLANK	H	--	BLANK
	INCH SERIES PRELOAD	C11	BLANK	H	BLANK	--
	CORRESPONDS TO ISO CLASS 4	PN7A	P4(PA7)	MM	BLANK	UP
	TIGHTER BORE AND O.D. ACCURACY FOR SU BEARINGS	PN7B	P4(PA7)	MM	BLANK	UP

The competitive manufacturers are provided for a convenient source of unit substitution. They can be considered interchangeable in most instances, but for special applications, please consult NSK Engineering. NSK assumes no liability with respect to errors or omissions.

Super Precision Machine Tool Bearing Applications

ABOUT NSK SUPER PRECISION MACHINE TOOL BEARINGS

This section covers three types of super precision bearings for use in machine tools. They are super precision angular contact ball bearings, super precision cylindrical roller bearings and screw support bearings.

The NSK super precision angular contact ball bearing is ideally designed to support the thrusting conditions in most machine tools while still running at very high speeds. The bearings are readily available with either 15° or 25° contact angles with either one of the high speed polyamide or phenolic cages.

The NSK super precision cylindrical roller bearing is superior for handling high radial loading conditions while operating with exceptional accuracy. These bearings are available with flanges on the outer ring or on the inner.

The NSK ball screw support bearing is ideally suited for the combined radial and axially loading to support the ball screw. The bearings have a high contact angle for precise positioning of the ball screw, maximum axial rigidity, and exact control of lateral eccentricity.

SUPER PRECISION ANGULAR CONTACT

- Machine Tool Spindles on:
 - Lathes
 - Boring Machinery
 - Grinders
 - Machining Centers
 - Milling Machines
 - Slicing Machines
 - Drilling Machines
 - Gem Cutting Machines

SUPER PRECISION CYLINDRICAL

- Machine Tool Spindles for float and high radial loadings.
- (N, NN) Design for exact positioning of the ball screw in a variety of machine tools.

BALL SCREW SUPPORT BEARINGS

- Precision Ball Screws



Super Precision Angular Contact

7000C Series
15° Contact Angle

Bearing Number	Basic Bearing Dimensions						Preferred Shoulder Dimensions				
	d		D		B		d _a min	D _a max	*D _b max	r _a max	*r _b max
	mm	inch	mm	inch	mm	inch	inch	inch	inch	inch	inch
7000 C	10	0.3937	26	1.0236	8	0.3150	0.492	0.925	0.976	0.012	0.006
7001 C	12	0.4724	28	1.1024	8	0.3150	0.571	1.004	1.055	0.012	0.006
7002 C	15	0.5906	32	1.2598	9	0.3543	0.689	1.161	1.213	0.012	0.006
7003 C	17	0.6693	35	1.3780	10	0.3937	0.768	1.280	1.331	0.012	0.006
7004 C	20	0.7874	42	1.6535	12	0.4724	0.984	1.457	1.555	0.024	0.012
7005 C	25	0.9843	47	1.8504	12	0.4724	1.181	1.654	1.752	0.024	0.012
7006 C	30	1.1811	55	2.1654	13	0.5118	1.417	1.929	1.969	0.039	0.020
7007 C	35	1.3780	62	2.4409	14	0.5512	1.614	2.205	2.244	0.039	0.020
7008 C	40	1.5748	68	2.6772	15	0.5906	1.811	2.441	2.480	0.039	0.020
7009 C	45	1.7717	75	2.9528	16	0.6299	2.008	2.717	2.756	0.039	0.020
7010 C	50	1.9685	80	3.1496	16	0.6299	2.205	2.913	2.953	0.039	0.020
7011 C	55	2.1654	90	3.5433	18	0.7087	2.441	3.268	3.346	0.039	0.024
7012 C	60	2.3622	95	3.7402	18	0.7087	2.638	3.465	3.543	0.039	0.024
7013 C	65	2.5591	100	3.9370	18	0.7087	2.835	3.661	3.740	0.039	0.024
7014 C	70	2.7559	110	4.3307	20	0.7874	3.031	4.055	4.134	0.039	0.024
7015 C	75	2.9528	115	4.5276	20	0.7874	3.228	4.252	4.331	0.039	0.024
7016 C	80	3.1496	125	4.9213	22	0.8661	3.425	4.646	4.724	0.039	0.024
7017 C	85	3.3465	130	5.1181	22	0.8661	3.622	4.843	4.921	0.039	0.024
7018 C	90	3.5433	140	5.5118	24	0.9449	3.898	5.157	5.276	0.059	0.031
7019 C	95	3.7402	145	5.7087	24	0.9449	4.094	5.354	5.472	0.059	0.031
7020 C	100	3.9370	150	5.9055	24	0.9449	4.291	5.551	5.669	0.059	0.031
7021 C	105	4.1339	160	6.2992	26	1.0236	4.528	5.906	6.063	0.079	0.039
7022 C	110	4.3307	170	6.6929	28	1.1024	4.724	6.299	6.457	0.079	0.039
7024 C	120	4.7244	180	7.0866	28	1.1024	5.118	6.693	6.850	0.079	0.039
7026 C	130	5.1181	200	7.8740	33	1.2992	5.512	7.480	7.638	0.079	0.039
7028 C	140	5.5118	210	8.2677	33	1.2992	5.906	7.874	8.031	0.079	0.039
7030 C	150	5.9055	225	8.8583	35	1.3780	6.378	8.386	8.583	0.079	0.039
7032 C	160	6.2992	240	9.4488	38	1.4961	6.772	8.976	9.173	0.079	0.039
7034 C	170	6.6929	260	10.2362	42	1.6535	7.165	9.764	9.961	0.079	0.039
7036 C	180	7.0866	280	11.0236	46	1.8110	7.559	10.551	10.748	0.079	0.039
7038 C	190	7.4803	290	11.4173	46	1.8110	7.953	10.945	11.142	0.079	0.039
7040 C	200	7.8740	310	12.2047	51	2.0079	8.346	11.732	11.929	0.079	0.039

*D_b is housing diameter for low shoulder.

r_b is housing fillet radius for low shoulder.

Application Data

Bearing Tolerances — Table 10.12 thru Table 10.16 on page 314-17
 Preload — Table 10.46 on page 337
 Shaft & Housing Fits — Contact NSK engineering

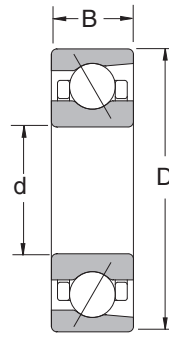
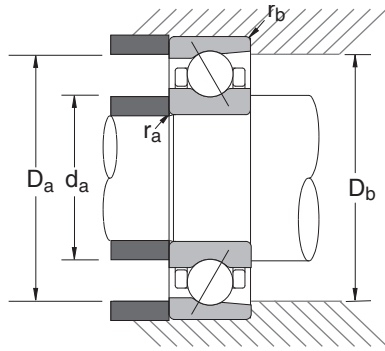

Common Options	
TR	: Phenolic cage
TY	: Polyamide cage
DU	: Duplex Universal
SU	: Single Universal
L	: Light Preload
M	: Medium Preload
H	: Heavy Preload
P4(PA7)	: ISO 4 (ABEC 7) Precision
P5(PA5)	: ISO 5 (ABEC 5) Precision

Bearing Number	Basic Load Ratings (lbs)		Limiting Speeds (1000 RPM)		Bearing Weight (Approx.)
	C_r	C_{or}	Grease	Oil	lbs
7000 C	1190	560	63.9	97.3	0.05
7001 C	1300	650	57.5	87.5	0.05
7002 C	1400	760	49	74.5	0.07
7003 C	1490	860	44.3	67.4	0.10
7004 C	2490	1470	37.1	56.5	0.17
7005 C	2620	1660	32	48.7	0.19
7006 C	3400	2310	27.1	41.2	0.29
7007 C	4300	3060	23.8	36.1	0.37
7008 C	4630	3570	21.3	32.5	0.46
7009 C	5490	4320	19.2	29.2	0.59
7010 C	5840	4920	17.7	27	0.64
7011 C	7720	6440	15.9	24.2	0.93
7012 C	7940	6940	14.9	22.6	0.99
7013 C	8380	7720	14	21.3	1.06
7014 C	10600	9700	12.8	19.5	1.49
7015 C	10800	10300	12.2	18.5	1.62
7016 C	13200	12500	11.3	17.1	2.11
7017 C	13600	13200	10.7	16.3	2.21
7018 C	16100	15500	10	15.3	2.91
7019 C	16500	16400	9.6	14.6	3.06
7020 C	17000	17400	9.2	14	3.18
7021 C	19800	20100	8.7	13.3	3.97
7022 C	23800	23400	8.3	12.5	4.94
7024 C	25100	26200	7.7	11.7	5.31
7026 C	29100	30900	7	10.7	8.03
7028 C	29800	32600	6.6	10	8.49
7030 C	34000	37900	6.2	9.4	10.30
7032 C	38400	43400	5.8	8.8	12.55
7034 C	46100	52700	5.4	8.2	17.20
7036 C	51400	61900	5	7.7	22.49
7038 C	55300	69400	4.8	7.3	24.48
7040 C	59500	76100	4.6	6.9	29.77

C_r = Dynamic Radial Load Rating
 C_{or} = Static Radial Load Rating

Introduction
 Ball Bearings
 Cylindrical Roller Bearings
 Spherical Roller Bearings
 Tapered Roller Bearings
 Thrust Bearings
 Split Pillow Blocks
 Super Precision Bearings
 Linear Motion
 Rolling Mill Bearings
 Engineering Section



Super Precision Angular Contact

7000A5 Series
25° Contact Angle

Bearing Number	Basic Bearing Dimensions						Preferred Shoulder Dimensions				
	d		D		B		d _a min	D _a max	*D _b max	r _a max	*r _b max
	mm	inch	mm	inch	mm	inch	inch	inch	inch	inch	inch
7000 A5	10	0.3937	26	1.0236	8	0.3150	0.492	0.925	0.976	0.012	0.006
7001 A5	12	0.4724	28	1.1024	8	0.3150	0.571	1.004	1.055	0.012	0.006
7002 A5	15	0.5906	32	1.2598	9	0.3543	0.689	1.161	1.213	0.012	0.006
7003 A5	17	0.6693	35	1.3780	10	0.3937	0.768	1.280	1.331	0.012	0.006
7004 A5	20	0.7874	42	1.6535	12	0.4724	0.984	1.457	1.555	0.024	0.012
7005 A5	25	0.9843	47	1.8504	12	0.4724	1.181	1.654	1.752	0.024	0.012
7006 A5	30	1.1811	55	2.1654	13	0.5118	1.417	1.929	1.969	0.039	0.020
7007 A5	35	1.3780	62	2.4409	14	0.5512	1.614	2.205	2.244	0.039	0.020
7008 A5	40	1.5748	68	2.6772	15	0.5906	1.811	2.441	2.480	0.039	0.020
7009 A5	45	1.7717	75	2.9528	16	0.6299	2.008	2.717	2.756	0.039	0.020
7010 A5	50	1.9685	80	3.1496	16	0.6299	2.205	2.913	2.953	0.039	0.020
7011 A5	55	2.1654	90	3.5433	18	0.7087	2.441	3.268	3.346	0.039	0.024
7012 A5	60	2.3622	95	3.7402	18	0.7087	2.638	3.465	3.543	0.039	0.024
7013 A5	65	2.5591	100	3.9370	18	0.7087	2.835	3.661	3.740	0.039	0.024
7014 A5	70	2.7559	110	4.3307	20	0.7874	3.031	4.055	4.134	0.039	0.024
7015 A5	75	2.9528	115	4.5276	20	0.7874	3.228	4.252	4.331	0.039	0.024
7016 A5	80	3.1496	125	4.9213	22	0.8661	3.425	4.646	4.724	0.039	0.024
7017 A5	85	3.3465	130	5.1181	22	0.8661	3.622	4.843	4.921	0.039	0.024
7018 A5	90	3.5433	140	5.5118	24	0.9449	3.898	5.157	5.276	0.059	0.031
7019 A5	95	3.7402	145	5.7087	24	0.9449	4.094	5.354	5.472	0.059	0.031
7020 A5	100	3.9370	150	5.9055	24	0.9449	4.291	5.551	5.669	0.059	0.031
7021 A5	105	4.1339	160	6.2992	26	1.0236	4.528	5.906	6.063	0.079	0.039
7022 A5	110	4.3307	170	6.6929	28	1.1024	4.724	6.299	6.457	0.079	0.039
7024 A5	120	4.7244	180	7.0866	28	1.1024	5.118	6.693	6.850	0.079	0.039
7026 A5	130	5.1181	200	7.8740	33	1.2992	5.512	7.480	7.638	0.079	0.039
7028 A5	140	5.5118	210	8.2677	33	1.2992	5.906	7.874	8.031	0.079	0.039
7030 A5	150	5.9055	225	8.8583	35	1.3780	6.378	8.386	8.583	0.079	0.039
7032 A5	160	6.2992	240	9.4488	38	1.4961	6.772	8.976	9.173	0.079	0.039
7034 A5	170	6.6929	260	10.2362	42	1.6535	7.165	9.764	9.961	0.079	0.039
7036 A5	180	7.0866	280	11.0236	46	1.8110	7.559	10.551	10.748	0.079	0.039
7038 A5	190	7.4803	290	11.4173	46	1.8110	7.953	10.945	11.142	0.079	0.039
7040 A5	200	7.8740	310	12.2047	51	2.0079	8.346	11.732	11.929	0.079	0.012

*D_b is housing diameter for low shoulder. r_b is housing fillet radius for low shoulder.

Application Data

Bearing Tolerances — Table 10.12 thru Table 10.16 on page 314-17
 Preload — Table 10.46 on page 337
 Shaft & Housing Fits — Contact NSK engineering

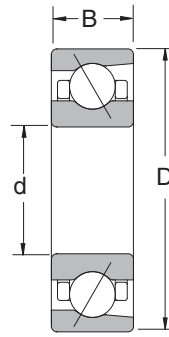
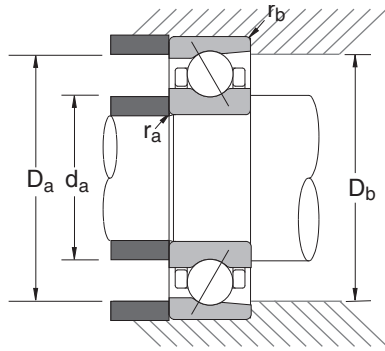

Common Options	
TR	: Phenolic cage
TY	: Polyamide cage
DU	: Duplex Universal
SU	: Single Universal
L	: Light Preload
M	: Medium Preload
H	: Heavy Preload
P4(PA7)	: ISO 4 (ABEC 7) Precision
P5(PA5)	: ISO 5 (ABEC 5) Precision

Bearing Number	Basic Load Ratings (lbs)		Limiting Speeds (1000 RPM)		Bearing Weight (Approx.)
	C_r	C_{or}	Grease	Oil	lbs
7000 A5	1160	540	55.6	83.4	0.04
7001 A5	1260	630	50	75	0.05
7002 A5	1340	730	42.6	63.9	0.07
7003 A5	1420	820	38.5	57.7	0.09
7004 A5	2380	1410	37.1	56.5	0.15
7005 A5	2510	1600	27.8	41.7	0.17
7006 A5	3240	2190	23.6	35.3	0.25
7007 A5	4080	2930	20.7	31	0.33
7008 A5	4390	3400	18.6	27.8	0.41
7009 A5	5200	4120	16.7	25	0.55
7010 A5	5530	4670	15.4	23.1	0.60
7011 A5	7280	6130	13.8	20.7	0.84
7012 A5	7500	6550	13	19.4	0.90
7013 A5	7940	7280	12.2	18.2	1.00
7014 A5	10000	9150	11.2	16.7	1.38
7015 A5	10300	9700	10.6	15.8	1.44
7016 A5	12500	11800	9.8	14.7	1.94
7017 A5	12800	12500	9.4	14	1.99
7018 A5	15200	14800	8.7	13.1	2.58
7019 A5	15700	15700	8.4	12.5	3.11
7020 A5	16000	16400	8	12	3.20
7021 A5	18700	19100	7.5	11.4	4.01
7022 A5	22500	22300	7.2	10.8	4.98
7024 A5	23800	24900	6.7	10	5.36
7026 A5	27600	29300	6.1	9.1	8.07
7028 A5	28000	30900	5.8	8.6	8.53
7030 A5	32000	35900	5.4	8	10.34
7032 A5	36400	41200	5	7.5	12.59
7034 A5	37500	43400	4.7	7	17.27
7036 A5	41700	51100	4.4	6.6	22.93
7038 A5	45000	56900	4.2	6.3	24.70
7040 A5	48300	63100	4	5.9	30.21

C_r = Dynamic Radial Load Rating
 C_{or} = Static Radial Load Rating

Introduction

Ball Bearings

Cylindrical Roller Bearings

Spherical Roller Bearings

Tapered Roller Bearings

Thrust Bearings

Split Pillow Blocks

Super Precision Bearings

Linear Motion

Rolling Mill Bearings

Engineering Section



Super Precision Angular Contact

7200C Series
15° Contact Angle

Bearing Number	Basic Bearing Dimensions						Preferred Shoulder Dimensions				
	d		D		B		d _a min	D _a max	*D _b max	r _a max	*r _b max
	mm	inch	mm	inch	mm	inch	inch	inch	inch	inch	inch
7200 C	10	0.3937	30	1.1811	9	0.3543	0.591	0.984	1.083	0.024	0.012
7201 C	12	0.4724	32	1.2598	10	0.3937	0.669	1.063	1.161	0.024	0.012
7202 C	15	0.5906	35	1.3780	11	0.4331	0.787	1.181	1.280	0.024	0.012
7203 C	17	0.6693	40	1.5748	12	0.4724	0.866	1.378	1.476	0.024	0.020
7204 C	20	0.7874	47	1.8504	14	0.5512	1.024	1.614	1.654	0.039	0.020
7205 C	25	0.9843	52	2.0472	15	0.5906	1.220	1.811	1.850	0.039	0.020
7206 C	30	1.1811	62	2.4409	16	0.6299	1.417	2.205	2.244	0.039	0.024
7207 C	35	1.3780	72	2.8346	17	0.6693	1.654	2.559	2.638	0.039	0.024
7208 C	40	1.5748	80	3.1496	18	0.7087	1.850	2.874	2.953	0.039	0.024
7209 C	45	1.7717	85	3.3465	19	0.7480	2.047	3.071	3.150	0.039	0.024
7210 C	50	1.9685	90	3.5433	20	0.7874	2.244	3.268	3.346	0.039	0.031
7211 C	55	2.1654	100	3.9370	21	0.8268	2.520	3.583	3.701	0.059	0.031
7212 C	60	2.3622	110	4.3307	22	0.8661	2.717	3.976	4.094	0.059	0.031
7213 C	65	2.5591	120	4.7244	23	0.9055	2.913	4.370	4.488	0.059	0.031
7214 C	70	2.7559	125	4.9213	24	0.9449	3.110	4.567	4.685	0.059	0.031
7215 C	75	2.9528	130	5.1181	25	0.9843	3.307	4.764	4.882	0.059	0.031
7216 C	80	3.1496	140	5.5118	26	1.0236	3.543	5.118	5.276	0.079	0.039
7217 C	85	3.3465	150	5.9055	28	1.1024	3.740	5.512	5.669	0.079	0.039
7218 C	90	3.5433	160	6.2992	30	1.1811	3.937	5.906	6.063	0.079	0.039
7219 C	95	3.7402	170	6.6929	32	1.2598	4.213	6.220	6.417	0.079	0.039
7220 C	100	3.9370	180	7.0866	34	1.3386	4.409	6.614	6.811	0.079	0.039
7221 C	105	4.1339	190	7.4803	36	1.4173	4.606	7.008	7.205	0.079	0.039
7222 C	110	4.3307	200	7.8740	38	1.4961	4.803	7.402	7.598	0.079	0.039
7224 C	120	4.7244	215	8.4646	40	1.5748	5.197	7.992	8.189	0.079	0.039
7226 C	130	5.1181	230	9.0551	40	1.5748	5.669	8.504	8.780	0.098	0.039
7228 C	140	5.5118	250	9.8425	42	1.6535	6.063	9.291	9.567	0.098	0.039
7230 C	150	5.9055	270	10.6299	45	1.7717	6.457	10.079	10.354	0.098	0.039
7232 C	160	6.2992	290	11.4173	48	1.8898	6.850	10.866	11.142	0.098	0.039
7234 C	170	6.6929	310	12.2047	52	2.0472	7.402	11.496	11.850	0.118	0.059
7236 C	180	7.0866	320	12.5984	52	2.0472	7.795	11.890	12.244	0.118	0.059
7238 C	190	7.4803	340	13.3858	55	2.1654	8.189	12.677	13.031	0.118	0.059
7240 C	200	7.8740	360	14.1732	58	2.2835	8.583	13.465	13.819	0.118	0.059

*D_b is housing diameter for low shoulder. r_b is housing fillet radius for low shoulder.

Application Data

Bearing Tolerances — Table 10.12 thru Table 10.16 on page 314-17
 Preload — Table 10.46 on page 337
 Shaft & Housing Fits — Contact NSK engineering

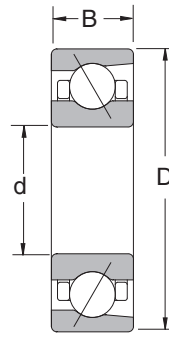
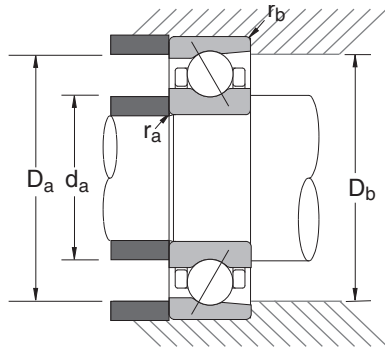

Common Options	
TR	: Phenolic cage
TY	: Polyamide cage
DU	: Duplex Universal
SU	: Single Universal
L	: Light Preload
M	: Medium Preload
H	: Heavy Preload
P4(PA7)	: ISO 4 (ABEC 7) Precision
P5(PA5)	: ISO 5 (ABEC 5) Precision

Bearing Number	Basic Load Ratings (lbs)		Limiting Speeds (1000 RPM)		Bearing Weight (Approx.)
	C_r	C_{or}	Grease	Oil	lbs
7200 C	1210	590	57.5	87.5	0.07
7201 C	1770	870	52.3	79.6	0.08
7202 C	1950	1010	46	70	0.09
7203 C	2450	1310	40.4	61.5	0.14
7204 C	3260	1820	34.4	52.3	0.22
7205 C	3730	2290	29.9	45.5	0.28
7206 C	5180	3310	25	38.1	0.42
7207 C	6830	4480	21.5	32.8	0.60
7208 C	8160	5670	19.2	29.2	0.79
7209 C	9150	6480	17.7	27	0.87
7210 C	9590	7170	16.5	25	0.99
7211 C	11900	9040	14.9	22.6	1.29
7212 C	14400	11000	13.6	20.6	1.69
7213 C	16400	13200	12.5	19	2.19
7214 C	17900	14600	11.8	18	2.36
7215 C	18600	15700	11.3	17.1	2.58
7216 C	20800	17400	10.5	16	3.09
7217 C	24000	20400	9.8	14.9	3.90
7218 C	27600	23600	9.2	14	4.83
7219 C	29800	25100	8.7	13.3	5.73
7220 C	33500	28400	8.3	12.5	6.90
7221 C	36600	32200	7.8	11.9	8.22
7222 C	39500	35900	7.5	11.3	9.70
7224 C	44800	43200	6.9	10.5	11.84
7226 C	46500	47000	6.4	9.8	13.60
7228 C	53600	57100	5.9	9	17.29
7230 C	60800	68300	5.5	8.4	24.48
7232 C	64400	75000	5.2	7.8	30.65
7234 C	71700	87100	4.8	7.3	38.37
7236 C	75000	93700	4.6	7	39.25
7238 C	77200	101000	4.4	6.7	48.73
7240 C	82700	110000	4.2	6.3	57.77

C_r = Dynamic Radial Load Rating
 C_{or} = Static Radial Load Rating

Introduction
 Ball Bearings
 Cylindrical Roller Bearings
 Spherical Roller Bearings
 Tapered Roller Bearings
 Thrust Bearings
 Split Pillow Blocks
 Super Precision Bearings
 Linear Motion
 Rolling Mill Bearings
 Engineering Section



Super Precision Angular Contact

7200A5 Series
25° Contact Angle

Bearing Number	Basic Bearing Dimensions						Preferred Shoulder Dimensions				
	d		D		B		d _a min	D _a max	*D _b max	r _a max	*r _b max
	mm	inch	mm	inch	mm	inch	inch	inch	inch	inch	inch
7200 A5	10	0.3937	30	1.1811	9	0.3543	0.591	0.984	1.083	0.024	0.012
7201 A5	12	0.4724	32	1.2598	10	0.3937	0.669	1.063	1.161	0.024	0.012
7202 A5	15	0.5906	35	1.3780	11	0.4331	0.787	1.181	1.280	0.024	0.012
7203 A5	17	0.6693	40	1.5748	12	0.4724	0.866	1.378	1.476	0.024	0.012
7204 A5	20	0.7874	47	1.8504	14	0.5512	1.024	1.614	1.654	0.039	0.020
7205 A5	25	0.9843	52	2.0472	15	0.5906	1.220	1.811	1.850	0.039	0.020
7206 A5	30	1.1811	62	2.4409	16	0.6299	1.417	2.205	2.244	0.039	0.020
7207 A5	35	1.3780	72	2.8346	17	0.6693	1.654	2.559	2.638	0.039	0.024
7208 A5	40	1.5748	80	3.1496	18	0.7087	1.850	2.874	2.953	0.039	0.024
7209 A5	45	1.7717	85	3.3465	19	0.7480	2.047	3.071	3.150	0.039	0.024
7210 A5	50	1.9685	90	3.5433	20	0.7874	2.244	3.268	3.346	0.039	0.024
7211 A5	55	2.1654	100	3.9370	21	0.8268	2.520	3.583	3.701	0.059	0.031
7212 A5	60	2.3622	110	4.3307	22	0.8661	2.717	3.976	4.094	0.059	0.031
7213 A5	65	2.5591	120	4.7244	23	0.9055	2.913	4.370	4.488	0.059	0.031
7214 A5	70	2.7559	125	4.9213	24	0.9449	3.110	4.567	4.685	0.059	0.031
7215 A5	75	2.9528	130	5.1181	25	0.9843	3.307	4.764	4.882	0.059	0.031
7216 A5	80	3.1496	140	5.5118	26	1.0236	3.543	5.118	5.276	0.079	0.039
7217 A5	85	3.3465	150	5.9055	28	1.1024	3.740	5.512	5.669	0.079	0.039
7218 A5	90	3.5433	160	6.2992	30	1.1811	3.937	5.906	6.063	0.079	0.039
7219 A5	95	3.7402	170	6.6929	32	1.2598	4.213	6.220	6.417	0.079	0.039
7220 A5	100	3.9370	180	7.0866	34	1.3386	4.409	6.614	6.811	0.079	0.039
7221 A5	105	4.1339	190	7.4803	36	1.4173	4.606	7.008	7.205	0.079	0.039
7222 A5	110	4.3307	200	7.8740	38	1.4961	4.803	7.402	7.598	0.079	0.039
7224 A5	120	4.7244	215	8.4646	40	1.5748	5.197	7.992	8.189	0.079	0.039
7226 A5	130	5.1181	230	9.0551	40	1.5748	5.669	8.504	8.780	0.098	0.039
7228 A5	140	5.5118	250	9.8425	42	1.6535	6.063	9.291	9.567	0.098	0.039
7230 A5	150	5.9055	270	10.6299	45	1.7717	6.457	10.079	10.354	0.098	0.039
7232 A5	160	6.2992	290	11.4173	48	1.8898	6.850	10.866	11.142	0.098	0.039
7234 A5	170	6.6929	310	12.2047	52	2.0472	7.402	11.496	11.850	0.118	0.059
7236 A5	180	7.0866	320	12.5984	52	2.0472	7.795	11.890	12.244	0.118	0.059
7238 A5	190	7.4803	340	13.3858	55	2.1654	8.189	12.677	13.031	0.118	0.059
7240 A5	200	7.8740	360	14.1732	58	2.2835	8.583	13.465	13.819	0.118	0.059

*D_b is housing diameter for low shoulder. r_b is housing fillet radius for low shoulder.

Application Data

Bearing Tolerances — Table 10.12 thru Table 10.16 on page 314-17
 Preload — Table 10.46 on page 337
 Shaft & Housing Fits — Contact NSK engineering

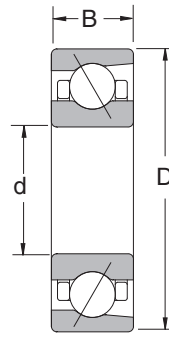
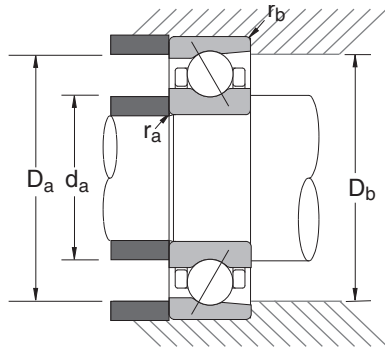

Common Options	
T	: Phenolic cage
TY	: Polyamid cage
DU	: Duplex Universal
SU	: Single Universal
L	: Light Preload
M	: Medium Preload
H	: Heavy Preload
P4(PA7)	: ISO 4 (ABEC 7) Precision
P5(PA5)	: ISO 5 (ABEC 5) Precision

Bearing Number	Basic Load Ratings (lbs)		Limiting Speeds (1000 RPM)		Bearing Weight (Approx.)
	C_r	C_{or}	Grease	Oil	lbs
7200 A5	1140	550	40.0	56.0	0.07
7201 A5	1720	840	36.0	50.0	0.08
7202 A5	1870	980	32.0	45.0	0.10
7203 A5	2360	1260	28.0	38.0	0.14
7204 A5	3150	1740	24.0	32.0	0.22
7205 A5	3570	2190	20.0	28.0	0.29
7206 A5	4960	3150	17.0	24.0	0.43
7207 A5	6550	4300	15.0	20.0	0.61
7208 A5	7830	5420	13.0	18.0	0.80
7209 A5	8820	6190	12.0	17.0	0.89
7210 A5	9150	6830	11.0	16.0	1.00
7211 A5	11400	8600	10.0	14.0	1.31
7212 A5	13800	10600	9.5	13.0	1.70
7213 A5	15700	12600	8.5	12.0	2.21
7214 A5	17100	13900	8.0	11.0	2.38
7215 A5	17700	15000	8.0	11.0	2.60
7216 A5	19800	16600	7.1	10.0	3.13
7217 A5	22900	19400	6.7	9.5	3.95
7218 A5	26200	22500	6.3	9.0	4.87
7219 A5	28400	24000	6.0	8.5	5.80
7220 A5	32000	27300	5.6	8.0	6.97
7221 A5	34800	30600	5.3	7.5	8.31
7222 A5	37700	34400	5.3	7.1	9.81
7224 A5	42500	41200	4.8	6.7	11.95
7226 A5	44100	44800	4.5	6.0	13.72
7228 A5	50900	54500	4.0	5.6	17.44
7230 A5	58000	65000	3.8	5.3	24.48
7232 A5	61300	71700	3.6	4.8	30.87
7234 A5	68300	83800	3.4	4.5	37.93
7236 A5	71700	89300	3.2	4.5	39.47
7238 A5	73900	95900	3.0	4.3	49.17
7240 A5	78300	105000	2.8	4.0	58.21

C_r = Dynamic Radial Load Rating
 C_{or} = Static Radial Load Rating

Introduction

Ball Bearings

Cylindrical Roller Bearings

Spherical Roller Bearings

Tapered Roller Bearings

Thrust Bearings

Split Pillow Blocks

Super Precision Bearings

Linear Motion

Rolling Mill Bearings

Engineering Section



Super Precision Angular Contact

7900C Series
15° Contact Angle

Bearing Number	Basic Bearing Dimensions						Preferred Shoulder Dimensions				
	d		D		B		d _a min	D _a max	*D _b max	r _a max	*r _b max
	mm	inch	mm	inch	mm	inch	inch	inch	inch	inch	inch
7900 C	10	0.3937	22	0.8661	6	0.2362	0.492	0.768	0.819	0.012	0.006
7901 C	12	0.4724	24	0.9449	6	0.2362	0.571	0.846	0.898	0.012	0.006
7902 C	15	0.5906	28	1.1024	7	0.2756	0.689	1.004	1.055	0.012	0.006
7903 C	17	0.6693	30	1.1811	7	0.2756	0.768	1.083	1.134	0.012	0.006
7904 C	20	0.7874	37	1.4567	9	0.3543	0.886	1.358	1.409	0.012	0.006
7905 C	25	0.9843	42	1.6535	9	0.3543	1.083	1.555	1.606	0.012	0.006
7906 C	30	1.1811	47	1.8504	9	0.3543	1.280	1.752	1.803	0.012	0.006
7907 C	35	1.3780	55	2.1654	10	0.3937	1.575	1.969	2.067	0.024	0.012
7908 C	40	1.5748	62	2.4409	12	0.4724	1.772	2.244	2.343	0.024	0.012
7909 C	45	1.7717	68	2.6772	12	0.4724	1.969	2.480	2.579	0.024	0.012
7910 C	50	1.9685	72	2.8346	12	0.4724	2.165	2.638	2.736	0.024	0.012
7911 C	55	2.1654	80	3.1496	13	0.5118	2.402	2.913	2.953	0.039	0.020
7912 C	60	2.3622	85	3.3465	13	0.5118	2.598	3.110	3.150	0.039	0.020
7913 C	65	2.5591	90	3.5433	13	0.5118	2.795	3.307	3.346	0.039	0.020
7914 C	70	2.7559	100	3.9370	16	0.6299	2.992	3.701	3.740	0.039	0.020
7915 C	75	2.9528	105	4.1339	16	0.6299	3.189	3.898	3.937	0.039	0.020
7916 C	80	3.1496	110	4.3307	16	0.6299	3.386	4.094	4.134	0.039	0.020
7917 C	85	3.3465	120	4.7244	18	0.7087	3.622	4.449	4.528	0.039	0.024
7918 C	90	3.5433	125	4.9213	18	0.7087	3.819	4.646	4.724	0.039	0.024
7919 C	95	3.7402	130	5.1181	18	0.7087	4.016	4.843	4.921	0.039	0.024
7920 C	100	3.9370	140	5.5118	20	0.7874	4.213	5.236	5.315	0.039	0.024
7921 C	105	4.1339	145	5.7087	20	0.7874	4.409	5.433	5.512	0.039	0.024
7922 C	110	4.3307	150	5.9055	20	0.7874	4.606	5.630	5.709	0.039	0.024
7924 C	120	4.7244	165	6.4961	22	0.8661	5.000	6.220	6.299	0.039	0.024
7926 C	130	5.1181	180	7.0866	24	0.9449	5.472	6.732	6.850	0.059	0.031
7928 C	140	5.5118	190	7.4803	24	0.9449	5.866	7.126	7.244	0.059	0.031
7930 C	150	5.9055	210	8.2677	28	1.1024	6.299	7.874	8.031	0.079	0.039
7932 C	160	6.2992	220	8.6614	28	1.1024	6.693	8.268	8.425	0.079	0.039
7934 C	170	6.6929	230	9.0551	28	1.1024	7.087	8.661	8.819	0.079	0.039
7936 C	180	7.0866	250	9.8425	33	1.2992	7.480	9.449	9.606	0.079	0.039
7938 C	190	7.4803	260	10.2362	33	1.2992	7.874	9.843	10.000	0.079	0.039
7940 C	200	7.8740	280	11.0236	38	1.4961	8.346	10.551	10.748	0.079	0.039

*D_b is housing diameter for low shoulder. r_b is housing fillet radius for low shoulder.

Application Data

Bearing Tolerances — Table 10.12 thru Table 10.16 on page 314-17
 Preload — Table 10.46 on page 337
 Shaft & Housing Fits — Contact NSK engineering

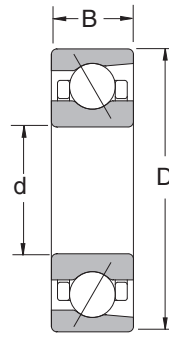
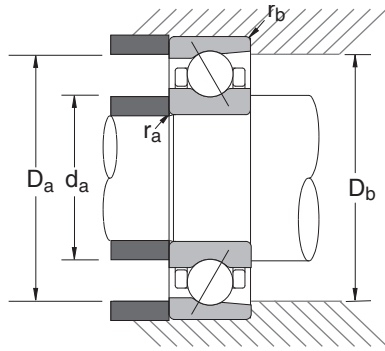

Common Options	
TR	: Phenolic cage
TY	: Polyamide cage
DU	: Duplex Universal
SU	: Single Universal
L	: Light Preload
M	: Medium Preload
H	: Heavy Preload
P4(PA7)	: ISO 4 (ABEC 7) Precision
P5(PA5)	: ISO 5 (ABEC 5) Precision

Bearing Number	Basic Load Ratings (lbs)		Limiting Speeds (1000 RPM)		Bearing Weight (Approx.)
	C_r	C_{or}	Grease	Oil	lbs
7900 C	670	340	71.9	109.4	0.02
7901 C	750	420	63.9	97.3	0.02
7902 C	1070	600	53.5	81.4	0.03
7903 C	1120	660	49	74.5	0.04
7904 C	1570	950	40.4	61.5	0.08
7905 C	1760	1220	34.4	52.3	0.09
7906 C	1860	1410	29.9	45.5	0.11
7907 C	2710	2050	25.6	38.9	0.16
7908 C	3400	2650	22.6	34.4	0.24
7909 C	3590	3000	20.4	31	0.28
7910 C	3790	3370	18.9	28.7	0.28
7911 C	4300	3990	17.1	26	0.39
7912 C	4370	4210	15.9	24.2	0.42
7913 C	4540	4610	14.9	22.6	0.45
7914 C	6330	6240	13.6	20.6	0.73
7915 C	6420	6570	12.8	19.5	0.78
7916 C	6530	6940	12.2	18.5	0.82
7917 C	8710	9150	11.3	17.1	1.15
7918 C	9370	10400	10.7	16.3	1.22
7919 C	9480	10800	10.3	15.6	1.28
7920 C	11200	12200	9.6	14.6	1.73
7921 C	11500	12800	9.2	14	1.79
7922 C	11700	13300	8.9	13.5	1.87
7924 C	16100	18300	8.1	12.3	2.51
7926 C	17600	20400	7.5	11.3	3.31
7928 C	17900	21400	7	10.7	3.55
7930 C	22900	27300	6.4	9.8	6.54
7932 C	23800	29800	6.1	9.3	6.81
7934 C	25400	33300	5.8	8.8	7.34
7936 C	32600	41400	5.4	8.2	10.80
7938 C	33100	43200	5.2	7.8	11.16
7940 C	42500	54900	4.8	7.3	15.10

C_r = Dynamic Radial Load Rating
 C_{or} = Static Radial Load Rating

Introduction
 Ball Bearings
 Cylindrical Roller Bearings
 Spherical Roller Bearings
 Tapered Roller Bearings
 Thrust Bearings
 Split Pillow Blocks
 Super Precision Bearings
 Linear Motion
 Rolling Mill Bearings
 Engineering Section



Super Precision Angular Contact

7900A5 Series
25° Contact Angle

Bearing Number	Basic Bearing Dimensions						Preferred Shoulder Dimensions				
	d		D		B		d _a min	D _a max	*D _b max	r _a max	*r _b max
	mm	inch	mm	inch	mm	inch	inch	inch	inch	inch	inch
7900 A5	10	0.3937	22	0.8661	6	0.2362	0.492	0.768	0.819	0.012	0.006
7901 A5	12	0.4724	24	0.9449	6	0.2362	0.571	0.846	0.898	0.012	0.006
7902 A5	15	0.5906	28	1.1024	7	0.2756	0.689	1.004	1.055	0.012	0.006
7903 A5	17	0.6693	30	1.1811	7	0.2756	0.768	1.083	1.134	0.012	0.006
7904 A5	20	0.7874	37	1.4567	9	0.3543	0.886	1.358	1.409	0.012	0.006
7905 A5	25	0.9843	42	1.6535	9	0.3543	1.083	1.555	1.606	0.012	0.006
7906 A5	30	1.1811	47	1.8504	9	0.3543	1.280	1.752	1.803	0.012	0.006
7907 A5	35	1.3780	55	2.1654	10	0.3937	1.575	1.969	2.067	0.024	0.012
7908 A5	40	1.5748	62	2.4409	12	0.4724	1.772	2.244	2.343	0.024	0.012
7909 A5	45	1.7717	68	2.6772	12	0.4724	1.969	2.480	2.579	0.024	0.012
7910 A5	50	1.9685	72	2.8346	12	0.4724	2.165	2.638	2.736	0.024	0.012
7911 A5	55	2.1654	80	3.1496	13	0.5118	2.402	2.913	2.953	0.039	0.020
7912 A5	60	2.3622	85	3.3465	13	0.5118	2.598	3.110	3.150	0.039	0.020
7913 A5	65	2.5591	90	3.5433	13	0.5118	2.795	3.307	3.346	0.039	0.020
7914 A5	70	2.7559	100	3.9370	16	0.6299	2.992	3.701	3.740	0.039	0.020
7915 A5	75	2.9528	105	4.1339	16	0.6299	3.189	3.898	3.937	0.039	0.020
7916 A5	80	3.1496	110	4.3307	16	0.6299	3.386	4.094	4.134	0.039	0.020
7917 A5	85	3.3465	120	4.7244	18	0.7087	3.622	4.449	4.528	0.039	0.024
7918 A5	90	3.5433	125	4.9213	18	0.7087	3.819	4.646	4.724	0.039	0.024
7919 A5	95	3.7402	130	5.1181	18	0.7087	4.016	4.843	4.921	0.039	0.024
7920 A5	100	3.9370	140	5.5118	20	0.7874	4.213	5.236	5.315	0.039	0.024
7921 A5	105	4.1339	145	5.7087	20	0.7874	4.409	5.433	5.512	0.039	0.024
7922 A5	110	4.3307	150	5.9055	20	0.7874	4.606	5.630	5.709	0.039	0.024
7924 A5	120	4.7244	165	6.4961	22	0.8661	5.000	6.220	6.299	0.039	0.024
7926 A5	130	5.1181	180	7.0866	24	0.9449	5.472	6.732	6.850	0.059	0.031
7928 A5	140	5.5118	190	7.4803	24	0.9449	5.866	7.126	7.244	0.059	0.031
7930 A5	150	5.9055	210	8.2677	28	1.1024	6.299	7.874	8.031	0.079	0.039
7932 A5	160	6.2992	220	8.6614	28	1.1024	6.693	8.268	8.425	0.079	0.039
7934 A5	170	6.6929	230	9.0551	28	1.1024	7.087	8.661	8.819	0.079	0.039
7936 A5	180	7.0866	250	9.8425	33	1.2992	7.480	9.449	9.606	0.079	0.039
7938 A5	190	7.4803	260	10.2362	33	1.2992	7.874	9.843	10.000	0.079	0.039
7940 A5	200	7.8740	280	11.0236	38	1.4961	8.346	10.551	10.748	0.079	0.039

*D_b is housing diameter for low shoulder. r_b is housing fillet radius for low shoulder.

Application Data

Bearing Tolerances — Table 10.12 thru Table 10.16 on page 314-17
 Preload — Table 10.46 on page 337
 Shaft & Housing Fits — Contact NSK engineering

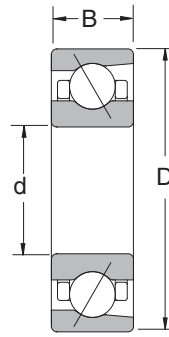
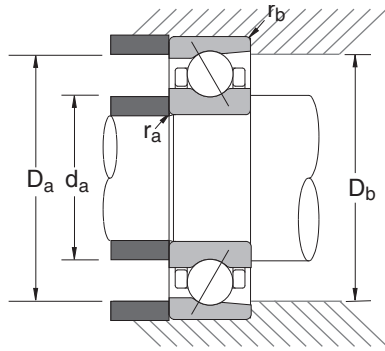

Common Options	
TR	: Phenolic cage
TY	: Polyamide cage
DU	: Duplex Universal
SU	: Single Universal
L	: Light Preload
M	: Medium Preload
H	: Heavy Preload
P4(PA7)	: ISO 4 (ABEC 7) Precision
P5(PA5)	: ISO 5 (ABEC 5) Precision

Bearing Number	Basic Load Ratings (lbs)		Limiting Speeds (1000 RPM)		Bearing Weight (Approx.)
	C_r	C_{or}	Grease	Oil	lbs
7900 A5	650	330	62.5	93.8	0.02
7901 A5	720	400	55.6	83.4	0.02
7902 A5	1030	570	46.6	69.8	0.03
7903 A5	1070	630	42.6	63.9	0.04
7904 A5	1490	900	35.1	52.7	0.08
7905 A5	1680	1160	29.9	44.8	0.09
7906 A5	1760	1330	26	39	0.11
7907 A5	2580	1950	22.3	33.4	0.16
7908 A5	3220	2510	19.7	29.5	0.24
7909 A5	3400	2840	17.7	26.6	0.28
7910 A5	3590	3200	16.4	24.6	0.29
7911 A5	4060	3770	14.9	22.3	0.40
7912 A5	4120	3990	13.8	20.7	0.38
7913 A5	4280	4370	13	19.4	0.45
7914 A5	5970	5910	11.8	17.7	0.74
7915 A5	6060	6220	11.2	16.7	0.78
7916 A5	6150	6530	10.6	15.8	0.83
7917 A5	8270	8600	9.8	14.7	1.16
7918 A5	8820	9810	9.4	14	1.23
7919 A5	8930	10300	8.9	13.4	1.30
7920 A5	10700	11600	8.4	12.5	1.75
7921 A5	10800	12100	8	12	1.81
7922 A5	11000	12700	7.7	11.6	1.89
7924 A5	15200	17300	7.1	10.6	2.54
7926 A5	16600	19300	6.5	9.7	3.35
7928 A5	16900	20300	6.1	9.1	3.59
7930 A5	21700	26000	5.6	8.4	6.55
7932 A5	22500	28200	5.3	7.9	6.88
7934 A5	23800	31500	5	7.5	7.41
7936 A5	30600	39200	4.7	7	10.89
7938 A5	31100	40800	4.5	6.7	11.29
7940 A5	40100	52000	4.2	6.3	15.26

C_r = Dynamic Radial Load Rating
 C_{or} = Static Radial Load Rating

Introduction

Ball Bearings

Cylindrical Roller Bearings

Spherical Roller Bearings

Tapered Roller Bearings

Thrust Bearings

Split Pillow Blocks

Super Precision Bearings

Linear Motion

Rolling Mill Bearings

Engineering Section



High Speed Super Precision Angular Contact

BNC Series (Steel ball)
15° Contact Angle

Part Number	Basic Bearing Dimensions						Preferred Shoulder Dimensions				
	d		D		B		d _a min	D _a max	*D _b max	r _a max	*r _b max
	mm	inch	mm	inch	mm	inch	inch	inch	inch	inch	inch
30BNC10	30	1.1811	55	2.1654	13	0.5118	1.417	1.929	1.969	0.039	0.020
35BNC10	35	1.3780	62	2.4409	14	0.5512	1.614	2.205	2.244	0.039	0.020
40BNC10	40	1.5748	68	2.6772	15	0.5906	1.811	2.441	2.480	0.039	0.020
45BNC10	45	1.7717	75	2.9528	16	0.6299	2.008	2.717	2.756	0.039	0.020
50BNC10	50	1.9685	80	3.1496	16	0.6299	2.205	2.913	2.953	0.039	0.020
55BNC10	55	2.1654	90	3.5433	18	0.7087	2.441	3.268	3.346	0.039	0.024
60BNC10	60	2.3622	95	3.7402	18	0.7087	2.638	3.465	3.543	0.039	0.024
65BNC10	65	2.5591	100	3.9370	18	0.7087	2.835	3.661	3.740	0.039	0.024
70BNC10	70	2.7559	110	4.3307	20	0.7874	0.433	4.055	4.134	0.039	0.024
75BNC10	75	2.9528	115	4.5276	20	0.7874	3.228	4.252	4.331	0.039	0.024
80BNC10	80	3.1496	125	4.9213	22	0.8661	3.425	4.646	4.724	0.039	0.024
85BNC10	85	3.3465	130	5.1181	22	0.8661	3.622	4.843	4.921	0.039	0.024
90BNC10	90	3.5433	140	5.5118	24	0.9449	3.898	5.157	5.276	0.059	0.031
95BNC10	95	3.7402	145	5.7087	24	0.9449	4.094	5.354	5.472	0.059	0.031
100BNC10	100	3.9370	150	5.9055	24	0.9449	4.173	5.551	5.669	0.059	0.031
105BNC10	105	4.1339	160	6.2992	26	1.0236	4.528	5.906	6.063	0.079	0.039
110BNC10	110	4.3307	170	6.6929	28	1.1024	4.724	6.299	6.457	0.079	0.039

Limiting Speeds

The limiting speeds listed in the Bearing Dimensional Tables are guideline values. They are based on a single bearing that is lightly preloaded by means of a spring and subjected to a relatively light loads with good heat dissipation.

The limiting speeds with grease lubrication are determined using high quality grease in appropriate amounts. Those listed for oil lubrication are based on the use of oil-air (or oil mist) lubrication. In situations where the lubricating oil is used as a means to remove heat, higher speed can be achieved, however a large amount of oil must be pressure fed through the bearing, so there is a significant loss of power.

When single bearings are used in two, three or four row combinations, or the preload is increased to improve spindle rigidity, limiting speeds will be lower than those listed.

Speed Factor

Arrangement	EL	L	M	H
DB	0.85	0.80	0.65	0.55
DBB	0.80	0.75	0.60	0.45
DBD	0.75	0.70	0.55	0.40

Introduction

Ball Bearings

Cylindrical Roller Bearings

Spherical Roller Bearings

Tapered Roller Bearings

Thrust Bearings

Split Pillow Blocks

Super Precision Bearings

Linear Motion

Rolling Mill Bearings

Engineering Section

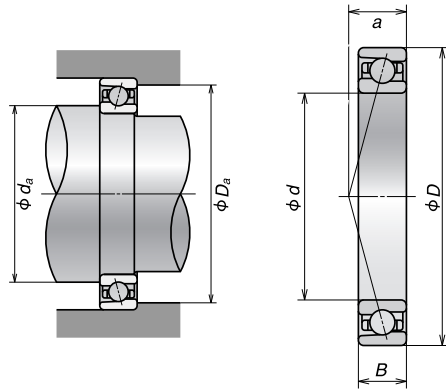

Common Options	
TR	: Phenolic cage
TY	: Polyamide cage
DU	: Duplex Universal
SU	: Single Universal
L	: Light Preload
M	: Medium Preload
H	: Heavy Preload
P4(PA7)	: ISO 4 (ABEC 7) Precision
P5(PA5)	: ISO 5 (ABEC 5) Precision

Part Number	Basic Load Ratings (lbs)		Limiting Speed Single or Tandem (RPM)		Bearing Weight (Approx.)	Preload Value Duplex (EL)
	C_r	C_{or}	Grease	Oil	lbs	lbs
30BNC10	2590	2000	28000	40000	0.27	11.24
35BNC10	2990	2450	26000	36000	0.36	11.24
40BNC10	3120	2740	22000	32000	0.44	11.24
45BNC10	3480	3150	20000	28000	0.56	11.24
50BNC10	3640	3460	19000	26000	0.61	11.24
55BNC10	4500	4380	17000	24000	0.90	11.24
60BNC10	4680	4790	15000	22000	0.97	11.24
65BNC10	4860	5220	15000	20000	1.05	11.24
70BNC10	6610	6860	13000	19000	1.40	11.24
75BNC10	6720	7190	13000	18000	1.48	11.24
80BNC10	7870	8540	12000	17000	2.02	22.48
85BNC10	7980	8880	11000	16000	2.11	22.48
90BNC10	10450	11580	11000	15000	2.71	22.48
95BNC10	10680	12030	10000	14000	2.82	22.48
100BNC10	10790	12590	9500	14000	2.93	22.48
105BNC10	12590	14950	9000	13000	3.81	22.48
110BNC10	13830	16410	8500	12000	4.65	22.48

C_r = Dynamic Radial Load Rating
 C_{or} = Static Radial Load Rating

Introduction

Ball Bearings

Cylindrical Roller Bearings

Spherical Roller Bearings

Tapered Roller Bearings

Thrust Bearings

Split Pillow Blocks

Super Precision Bearings

Linear Motion

Rolling Mill Bearings

Engineering Section



High Speed Super Precision Angular Contact

BNC Series (Ceramic ball) (Continued)
15° Contact Angle

Part Number	Basic Bearing Dimensions						Preferred Shoulder Dimensions				
	d		D		B		d _a min	D _a max	*D _b max	r _a max	*r _b max
	mm	inch	mm	inch	mm	inch	inch	inch	inch	inch	inch
30BNC10SN24	30	1.1811	55	2.1654	13	0.5118	1.417	1.929	1.969	0.039	0.020
35BNC10SN24	35	1.3780	62	2.4409	14	0.5512	1.614	2.205	2.244	0.039	0.020
40BNC10SN24	40	1.5748	68	2.6772	15	0.5906	1.811	2.441	2.480	0.039	0.020
45BNC10SN24	45	1.7717	75	2.9528	16	0.6299	2.008	2.717	2.756	0.039	0.020
50BNC10SN24	50	1.9685	80	3.1496	16	0.6299	2.205	2.913	2.953	0.039	0.020
55BNC10SN24	55	2.1654	90	3.5433	18	0.7087	2.441	3.268	3.346	0.039	0.024
60BNC10SN24	60	2.3622	95	3.7402	18	0.7087	2.638	3.465	3.543	0.039	0.024
65BNC10SN24	65	2.5591	100	3.9370	18	0.7087	2.835	3.661	3.740	0.039	0.024
70BNC10SN24	70	2.7559	110	4.3307	20	0.7874	0.433	4.055	4.134	0.039	0.024
75BNC10SN24	75	2.9528	115	4.5276	20	0.7874	3.228	4.252	4.331	0.039	0.024
80BNC10SN24	80	3.1496	125	4.9213	22	0.8661	3.425	4.646	4.724	0.039	0.024
85BNC10SN24	85	3.3465	130	5.1181	22	0.8661	3.622	4.843	4.921	0.039	0.024
90BNC10SN24	90	3.5433	140	5.5118	24	0.9449	3.898	5.157	5.276	0.059	0.031
95BNC10SN24	95	3.7402	145	5.7087	24	0.9449	4.094	5.354	5.472	0.059	0.031
100BNC10SN24	100	3.9370	150	5.9055	24	0.9449	4.173	5.551	5.669	0.059	0.031
105BNC10SN24	105	4.1339	160	6.2992	26	1.0236	4.528	5.906	6.063	0.079	0.039
110BNC10SN24	110	4.3307	170	6.6929	28	1.1024	4.724	6.299	6.457	0.079	0.039

Limiting Speeds

The limiting speeds listed in the Bearing Dimensional Tables are guideline values. They are based on a single bearing that is lightly preloaded by means of a spring and subjected to a relatively light loads with good heat dissipation.

The limiting speeds with grease lubrication are determined using high quality grease in appropriate amounts. Those listed for oil lubrication are based on the use of oil-air (or oil mist) lubrication. In situations where the lubricating oil is used as a means to remove heat, higher speed can be achieved, however a large amount of oil must be pressure fed through the bearing, so there is a significant loss of power.

When single bearings are used in two, three or four row combinations, or the preload is increased to improve spindle rigidity, limiting speeds will be lower than those listed.

Speed Factor

Arrangement	EL	L	M	H
DB	0.85	0.80	0.65	0.55
DBB	0.80	0.75	0.60	0.45
DBD	0.75	0.70	0.55	0.40

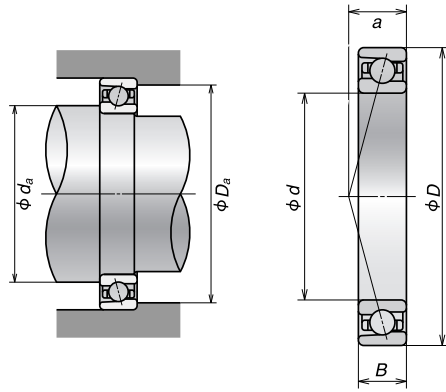

Common Options	
TR	: Phenolic cage
TY	: Polyamide cage
DU	: Duplex Universal
SU	: Single Universal
L	: Light Preload
M	: Medium Preload
H	: Heavy Preload
P4(PA7)	: ISO 4 (ABEC 7) Precision
P5(PA5)	: ISO 5 (ABEC 5) Precision

Part Number	Basic Load Ratings (lbs)		Limiting Speed Single or Tandem (RPM)		Bearing Weight (Approx.)	Preload Value Duplex (EL)
	C_r	C_{or}	Grease	Oil	lbs	lbs
30BNC10SN24	2590	2000	34000	57000	0.27	11.24
35BNC10SN24	2990	2450	30000	50000	0.36	11.24
40BNC10SN24	3120	2740	27000	45000	0.44	11.24
45BNC10SN24	3480	3150	24000	41000	0.56	11.24
50BNC10SN24	3640	3460	22000	38000	0.61	11.24
55BNC10SN24	4500	4380	20000	34000	0.90	11.24
60BNC10SN24	4680	4790	19000	31000	0.97	11.24
65BNC10SN24	4860	5220	17000	30000	1.05	11.24
70BNC10SN24	6610	6860	16000	27000	1.40	11.24
75BNC10SN24	6720	7190	15000	26000	1.48	11.24
80BNC10SN24	7870	8540	14000	24000	2.02	22.48
85BNC10SN24	7980	8880	13000	23000	2.11	22.48
90BNC10SN24	10450	11580	13000	21000	2.71	22.48
95BNC10SN24	10680	12030	12000	20000	2.82	22.48
100BNC10SN24	10790	12590	12000	20000	2.93	22.48
105BNC10SN24	12590	14950	11000	18000	3.81	22.48
110BNC10SN24	13830	16410	10000	17000	4.65	22.48

C_r = Dynamic Radial Load Rating
 C_{or} = Static Radial Load Rating

Introduction

Ball Bearings

Cylindrical Roller Bearings

Spherical Roller Bearings

Tapered Roller Bearings

Thrust Bearings

Split Pillow Blocks

Super Precision Bearings

Linear Motion

Rolling Mill Bearings

Engineering Section



High Speed Super Precision Angular Contact

BNR Series - ROBUST (Steel ball)
18° Contact Angle

Part Number	Basic Bearing Dimensions						Preferred Shoulder Dimensions				
	d		D		B		d _a min	D _a max	*D _b max	r _a max	*r _b max
	mm	inch	mm	inch	mm	inch	inch	inch	inch	inch	inch
30BNR10S	30	1.1811	55	2.1654	13	0.5118	1.417	1.929	1.969	0.039	0.020
35BNR10S	35	1.3780	62	2.4409	14	0.5512	1.614	2.205	2.244	0.039	0.020
40BNR10S	40	1.5748	68	2.6772	15	0.5906	1.811	2.441	2.480	0.039	0.020
45BNR10S	45	1.7717	75	2.9528	16	0.6299	2.008	2.717	2.756	0.039	0.020
50BNR10S	50	1.9685	80	3.1496	16	0.6299	2.205	2.913	2.953	0.039	0.020
55BNR10S	55	2.1654	90	3.5433	18	0.7087	2.441	3.268	3.346	0.039	0.024
60BNR10S	60	2.3622	95	3.7402	18	0.7087	2.638	3.465	3.543	0.039	0.024
65BNR10S	65	2.5591	100	3.9370	18	0.7087	2.835	3.661	3.740	0.039	0.024
70BNR10S	70	2.7559	110	4.3307	20	0.7874	0.433	4.055	4.134	0.039	0.024
75BNR10S	75	2.9528	115	4.5276	20	0.7874	3.228	4.252	4.331	0.039	0.024
80BNR10S	80	3.1496	125	4.9213	22	0.8661	3.425	4.646	4.724	0.039	0.024
85BNR10S	85	3.3465	130	5.1181	22	0.8661	3.622	4.843	4.921	0.039	0.024
90BNR10S	90	3.5433	140	5.5118	24	0.9449	3.898	5.157	5.276	0.059	0.031
95BNR10S	95	3.7402	145	5.7087	24	0.9449	4.094	5.354	5.472	0.059	0.031
100BNR10S	100	3.9370	150	5.9055	24	0.9449	4.291	5.551	5.669	0.059	0.031

Limiting Speeds

The limiting speeds listed in the Bearing Dimensional Tables are guideline values. They are based on a single bearing that is lightly preloaded by means of a spring and subjected to a relatively light loads with good heat dissipation.

The limiting speeds with grease lubrication are determined using high quality grease in appropriate amounts. Those listed for oil lubrication are based on the use of oil-air (or oil mist) lubrication. In situations where the lubricating oil is used as a means to remove heat, higher speed can be achieved, however a large amount of oil must be pressure fed through the bearing, so there is a significant loss of power.

When single bearings are used in two, three or four row combinations, or the preload is increased to improve spindle rigidity, limiting speeds will be lower than those listed.

Speed Factor

Arrangement	EL	L	M	H
DB	0.85	0.80	0.65	0.55
DBB	0.80	0.75	0.60	0.45
DBD	0.75	0.70	0.55	0.40

Introduction

Ball Bearings

Cylindrical Roller Bearings

Spherical Roller Bearings

Tapered Roller Bearings

Thrust Bearings

Split Pillow Blocks

Super Precision Bearings

Linear Motion

Rolling Mill Bearings

Engineering Section

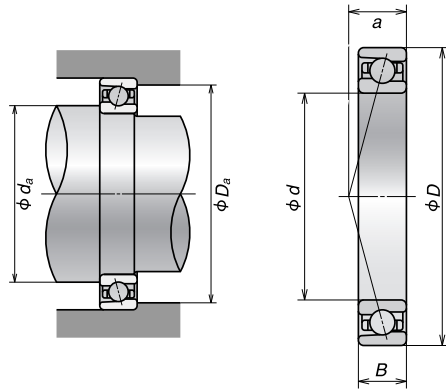

Common Options	
TR	: Phenolic cage
TY	: Polyamide cage
DU	: Duplex Universal
SU	: Single Universal
L	: Light Preload
M	: Medium Preload
H	: Heavy Preload
P4(PA7)	: ISO 4 (ABEC 7) Precision
P5(PA5)	: ISO 5 (ABEC 5) Precision

Part Number	Basic Load Ratings (lbs)		Limiting Speed Single or Tandem (RPM)		Bearing Weight (Approx.)	Preload Value Duplex (EL)
	C_r	C_{or}	Grease	Oil	lbs	lbs
30BNR10S	1940	1290	33000	47100	0.273	11.24
35BNR10S	2270	1600	28900	41300	0.362	11.24
40BNR10S	2380	1790	26000	37100	0.450	11.24
45BNR10S	2630	2020	23400	33400	0.571	11.24
50BNR10S	2740	2230	21600	30800	0.620	11.24
55BNR10S	3390	2810	19400	27600	0.913	11.24
60BNR10S	3510	3080	18100	25900	0.977	11.24
65BNR10S	3640	3330	17000	24300	1.041	11.24
70BNR10S	5010	4450	15600	22300	1.422	11.24
75BNR10S	5080	4650	14800	21100	1.497	11.24
80BNR10S	5960	5510	13700	19600	2.031	22.48
85BNR10S	6020	5780	13100	18700	2.121	22.48
90BNR10S	7870	7420	12200	17400	2.736	22.48
95BNR10S	7980	7760	11700	16700	2.862	22.48
100BNR10S	8090	8090	11200	16000	2.745	22.48

C_r = Dynamic Radial Load Rating
 C_{or} = Static Radial Load Rating

Introduction

Ball Bearings

Cylindrical Roller Bearings

Spherical Roller Bearings

Tapered Roller Bearings

Thrust Bearings

Split Pillow Blocks

Super Precision Bearings

Linear Motion

Rolling Mill Bearings

Engineering Section



Super Precision Angular Contact

BNR Series - ROBUST (Ceramic ball) (Continued)
18° Contact Angle

Part Number	Basic Bearing Dimensions						Preferred Shoulder Dimensions				
	d		D		B		d _a min	D _a max	*D _b max	r _a max	*r _b max
	mm	inch	mm	inch	mm	inch	inch	inch	inch	inch	inch
30BNR10H	30	1.1811	55	2.1654	13	0.5118	1.417	1.929	1.969	0.039	0.020
35BNR10H	35	1.3780	62	2.4409	14	0.5512	1.614	2.205	2.244	0.039	0.020
40BNR10H	40	1.5748	68	2.6772	15	0.5906	1.811	2.441	2.480	0.039	0.020
45BNR10H	45	1.7717	75	2.9528	16	0.6299	2.008	2.717	2.756	0.039	0.020
50BNR10H	50	1.9685	80	3.1496	16	0.6299	2.205	2.913	2.953	0.039	0.020
55BNR10H	55	2.1654	90	3.5433	18	0.7087	2.441	3.268	3.346	0.039	0.024
60BNR10H	60	2.3622	95	3.7402	18	0.7087	2.638	3.465	3.543	0.039	0.024
65BNR10H	65	2.5591	100	3.9370	18	0.7087	2.835	3.661	3.740	0.039	0.024
70BNR10H	70	2.7559	110	4.3307	20	0.7874	0.433	4.055	4.134	0.039	0.024
75BNR10H	75	2.9528	115	4.5276	20	0.7874	3.228	4.252	4.331	0.039	0.024
80BNR10H	80	3.1496	125	4.9213	22	0.8661	3.425	4.646	4.724	0.039	0.024
85BNR10H	85	3.3465	130	5.1181	22	0.8661	3.622	4.843	4.921	0.039	0.024
90BNR10H	90	3.5433	140	5.5118	24	0.9449	3.898	5.157	5.276	0.059	0.031
95BNR10H	95	3.7402	145	5.7087	24	0.9449	4.094	5.354	5.472	0.059	0.031
100BNR10H	100	3.9370	150	5.9055	24	0.9449	4.291	5.551	5.669	0.059	0.031

Limiting Speeds

The limiting speeds listed in the Bearing Dimensional Tables are guideline values. They are based on a single bearing that is lightly preloaded by means of a spring and subjected to a relatively light loads with good heat dissipation.

The limiting speeds with grease lubrication are determined using high quality grease in appropriate amounts. Those listed for oil lubrication are based on the use of oil-air (or oil mist) lubrication. In situations where the lubricating oil is used as a means to remove heat, higher speed can be achieved, however a large amount of oil must be pressure fed through the bearing, so there is a significant loss of power.

When single bearings are used in two, three or four row combinations, or the preload is increased to improve spindle rigidity, limiting speeds will be lower than those listed.

Speed Factor

Arrangement	EL	L	M	H
DB	0.85	0.80	0.65	0.55
DBB	0.80	0.75	0.60	0.45
DBD	0.75	0.70	0.55	0.40

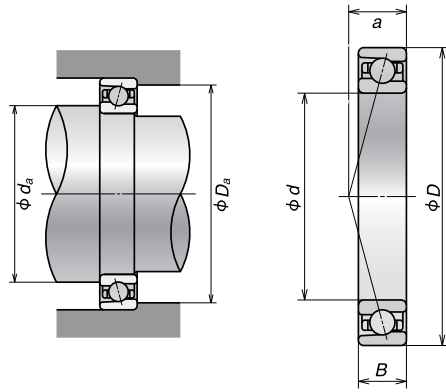

Common Options	
TR	: Phenolic cage
TY	: Polyamide cage
DU	: Duplex Universal
SU	: Single Universal
L	: Light Preload
M	: Medium Preload
H	: Heavy Preload
P4(PA7)	: ISO 4 (ABEC 7) Precision
P5(PA5)	: ISO 5 (ABEC 5) Precision

Part Number	Basic Load Ratings (lbs)		Limiting Speed Single or Tandem (RPM)		Bearing Weight (Approx.)	Preload Value Duplex (EL)
	C_r	C_{or}	Grease	Oil	lbs	lbs
30BNR10H	1940	1290	42400	65900	0.273	11.24
35BNR10H	2270	1600	37200	57800	0.362	11.24
40BNR10H	2380	1790	33400	51900	0.450	11.24
45BNR10H	2630	2020	30000	46700	0.571	11.24
50BNR10H	2740	2230	27700	43100	0.620	11.24
55BNR10H	3390	2810	24900	38700	0.913	11.24
60BNR10H	3510	3080	23300	36200	0.977	11.24
65BNR10H	3640	3330	21900	34000	1.041	11.24
70BNR10H	5010	4450	20000	31200	1.422	11.24
75BNR10H	5080	4650	19000	29500	1.497	11.24
80BNR10H	5960	5510	17600	27400	2.031	22.48
85BNR10H	6020	5780	16800	26100	2.121	22.48
90BNR10H	7870	7420	15700	24400	2.736	22.48
95BNR10H	7980	7760	15000	23400	2.862	22.48
100BNR10H	8090	8090	14400	22400	2.745	22.48

C_r = Dynamic Radial Load Rating
 C_{or} = Static Radial Load Rating

Introduction

Ball Bearings

Cylindrical Roller Bearings

Spherical Roller Bearings

Tapered Roller Bearings

Thrust Bearings

Split Pillow Blocks

Super Precision Bearings

Linear Motion

Rolling Mill Bearings

Engineering Section



High Speed Super Precision Angular Contact

BGR Series (Steel ball)

15° Contact Angle

Part Number	Basic Bearing Dimensions						Preferred Shoulder Dimensions			
	d		D		B		d _a min	D _a max	r _a max	*r _b max
	mm	inch	mm	inch	mm	inch	inch	inch	inch	inch
6BGR10S	6	0.2362	17	0.6693	6	0.2362	0.335	0.571	0.012	-
7BGR10S	7	0.2756	19	0.7480	6	0.2362	0.374	0.650	0.012	-
8BGR10S	8	0.3150	22	0.8661	7	0.2756	0.413	0.768	0.012	-
10BGR10S	10	0.3937	26	1.0236	8	0.3150	0.492	0.925	0.012	0.0059
12BGR10S	12	0.4724	28	1.1024	8	0.3150	0.571	1.004	0.012	0.0059
15BGR10S	15	0.5906	32	1.2598	9	0.3543	0.689	1.161	0.012	0.0059
17BGR10S	17	0.6693	35	1.3780	10	0.3937	0.768	1.280	0.012	0.0059
20BGR10S	20	0.7874	42	1.6535	12	0.4724	0.984	1.457	0.024	0.0118
25BGR10S	25	0.9843	47	1.8504	12	0.4724	1.181	1.654	0.024	0.0118

Limiting Speeds

The limiting speeds listed in the Bearing Dimensional Tables are guideline values. They are based on a single bearing that is lightly preloaded by means of a spring and subjected to a relatively light loads with good heat dissipation.

The limiting speeds with grease lubrication are determined using high quality grease in appropriate amounts. Those listed for oil lubrication are based on the use of oil-air (or oil mist) lubrication. In situations where the lubricating oil is used as a means to remove heat, higher speed can be achieved, however a large amount of oil must be pressure fed through the bearing, so there is a significant loss of power.

When single bearings are used in two, three or four row combinations, or the preload is increased to improve spindle rigidity, limiting speeds will be lower than those listed.

Speed Factor

Arrangement	EL	L	M	H
DB	0.85	0.80	0.65	0.55
DBB	0.80	0.75	0.60	0.45
DBD	0.75	0.70	0.55	0.40

Introduction

Ball Bearings

Cylindrical Roller Bearings

Spherical Roller Bearings

Tapered Roller Bearings

Thrust Bearings

Split Pillow Blocks

Super Precision Bearings

Linear Motion

Rolling Mill Bearings

Engineering Section

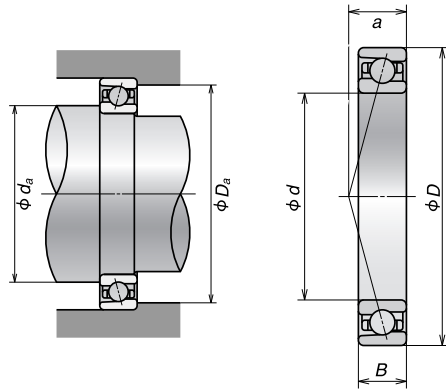

Common Options	
TR	: Phenolic cage
TY	: Polyamide cage
DU	: Duplex Universal
SU	: Single Universal
L	: Light Preload
M	: Medium Preload
H	: Heavy Preload
P4(PA7)	: ISO 4 (ABEC 7) Precision
P5(PA5)	: ISO 5 (ABEC 5) Precision

Part Number	Basic Load Ratings (lbs)		Limiting Speed Single or Tandem 1000 (RPM)		Bearing Weight (Approx.)
	C_r	C_{or}	Grease	Oil	lbs
6BGR10S	320	100	140	192	0.01
7BGR10S	370	120	124	170	0.02
8BGR10S	530	180	107	147	0.03
10BGR10S	800	290	88.9	123	0.04
12BGR10S	880	330	80	110	0.05
15BGR10S	940	390	68.1	93.7	0.06
17BGR10S	1010	440	61.6	84.7	0.08
20BGR10S	1690	750	51.7	71	0.15
25BGR10S	1790	850	44.5	61.2	0.17

C_r = Dynamic Radial Load Rating
 C_{or} = Static Radial Load Rating

Introduction

Ball Bearings

Cylindrical Roller Bearings

Spherical Roller Bearings

Tapered Roller Bearings

Thrust Bearings

Split Pillow Blocks

Super Precision Bearings

Linear Motion

Rolling Mill Bearings

Engineering Section



Super Precision Angular Contact

BGR Series (Ceramic ball) (Continued)

15° Contact Angle

Part Number	Basic Bearing Dimensions						Preferred Shoulder Dimensions			
	d		D		B		d _a min	D _a max	r _a max	*r _b max
	mm	inch	mm	inch	mm	inch	inch	inch	inch	inch
6BGR10H	6	0.2362	17	0.6693	6	0.2362	0.335	0.571	0.012	-
7BGR10H	7	0.2756	19	0.7480	6	0.2362	0.374	0.650	0.012	-
8BGR10H	8	0.3150	22	0.8661	7	0.2756	0.413	0.768	0.012	-
10BGR10H	10	0.3937	26	1.0236	8	0.3150	0.492	0.925	0.012	0.0059
12BGR10H	12	0.4724	28	1.1024	8	0.3150	0.571	1.004	0.012	0.0059
15BGR10H	15	0.5906	32	1.2598	9	0.3543	0.689	1.161	0.012	0.0059
17BGR10H	17	0.6693	35	1.3780	10	0.3937	0.768	1.280	0.012	0.0059
20BGR10H	20	0.7874	42	1.6535	12	0.4724	0.984	1.457	0.024	0.0118
25BGR10H	25	0.9843	47	1.8504	12	0.4724	1.181	1.654	0.024	0.0118

Limiting Speeds

The limiting speeds listed in the Bearing Dimensional Tables are guideline values. They are based on a single bearing that is lightly preloaded by means of a spring and subjected to a relatively light loads with good heat dissipation.

The limiting speeds with grease lubrication are determined using high quality grease in appropriate amounts. Those listed for oil lubrication are based on the use of oil-air (or oil mist) lubrication. In situations where the lubricating oil is used as a means to remove heat, higher speed can be achieved, however a large amount of oil must be pressure fed through the bearing, so there is a significant loss of power.

When single bearings are used in two, three or four row combinations, or the preload is increased to improve spindle rigidity, limiting speeds will be lower than those listed.

Speed Factor

Arrangement	EL	L	M	H
DB	0.85	0.80	0.65	0.55
DBB	0.80	0.75	0.60	0.45
DBD	0.75	0.70	0.55	0.40

Introduction

Ball Bearings

Cylindrical Roller Bearings

Spherical Roller Bearings

Tapered Roller Bearings

Thrust Bearings

Split Pillow Blocks

Super Precision Bearings

Linear Motion

Rolling Mill Bearings

Engineering Section

Part Number	Basic Load Ratings (lbs)		Limiting Speed Single or Tandem 1000 (RPM)		Bearing Weight (Approx.)
	C_r	C_{or}	Grease	Oil	lbs
6BGR10H	320	100	166	244	0.01
7BGR10H	370	120	147	216	0.02
8BGR10H	530	180	127	187	0.03
10BGR10H	800	290	106	156	0.04
12BGR10H	880	330	95	140	0.05
15BGR10H	940	390	80.9	120	0.06
17BGR10H	1010	440	73.1	108	0.08
20BGR10H	1690	750	61.3	90.4	0.15
25BGR10H	1790	850	52.8	77.8	0.17

C_r = Dynamic Radial Load Rating
 C_{or} = Static Radial Load Rating

Introduction

Ball Bearings

Cylindrical Roller Bearings

Spherical Roller Bearings

Tapered Roller Bearings

Thrust Bearings

Split Pillow Blocks

Super Precision Bearings

Linear Motion

Rolling Mill Bearings

Engineering Section



Super Precision Thrust Angular Contact

BAR Series

30° Contact Angle

Part Number	Basic Bearing Dimensions						Preferred Shoulder Dimensions		
	d		D		B		d _a min	D _b max	*r _b max
	mm	inch	mm	inch	mm	inch	inch	inch	inch
60BAR10S	60	2.3622	95	3.7402	16.5	0.6496	2.6378	3.54331	0.02362
65BAR10S	65	2.5591	100	3.9370	16.5	0.6496	2.8346	3.74015	0.02362
70BAR10S	70	2.7559	110	4.3307	18	0.7087	3.0315	4.13385	0.02362
75BAR10S	75	2.9528	115	4.5276	18	0.7087	3.2283	4.33070	0.02362
80BAR10S	80	3.1496	125	4.9213	20.25	0.7972	3.4252	4.72440	0.02362
85BAR10S	85	3.3465	130	5.1181	20.25	0.7972	3.6220	4.92125	0.02362
90BAR10S	90	3.5433	140	5.5118	22.5	0.8858	3.8976	5.27559	0.03937
95BAR10S	95	3.7402	145	5.7087	22.5	0.8858	4.0945	5.47244	0.03937
100BAR10S	100	3.9370	150	5.9055	22.5	0.8858	4.2913	5.66929	0.03937
105BAR10S	105	4.1339	160	6.2992	24.75	0.9744	4.5276	6.06299	0.03937
110BAR10S	110	4.3307	170	6.6929	27	1.0630	4.7244	6.45669	0.03937
120BAR10S	120	4.7244	180	7.0866	27	1.0630	5.1181	6.85039	0.03937
130BAR10S	130	5.1181	200	7.8740	31.5	1.2402	5.5118	7.63779	0.03937

Introduction

Ball Bearings

Cylindrical Roller Bearings

Spherical Roller Bearings

Tapered Roller Bearings

Thrust Bearings

Split Pillow Blocks

Super Precision Bearings

Linear Motion

Rolling Mill Bearings

Engineering Section



Common Options	
TR	: Phenolic cage
TY	: Polyamide cage
DU	: Duplex Universal
SU	: Single Universal
L	: Light Preload
M	: Medium Preload
H	: Heavy Preload
P4(PA7)	: ISO 4 (ABEC 7) Precision
P5(PA5)	: ISO 5 (ABEC 5) Precision

Part Number	Basic Load Ratings (lbs)		Limiting Speed Duplex (RPM)		Bearing Weight (Approx.)	Preload Value Duplex (EL)	Axial Rigidity Duplex (EL)
	C_r	C_{or}	Grease	Oil	lbs	lbs	lbs/.001 inch
60BAR10S	4249	8543	9 700	12 300	0.93	53.95	1084.9
65BAR10S	4384	9330	9 100	11 600	0.99	56.20	1142
70BAR10S	6047	12364	8 400	10 600	1.32	56.20	1142
75BAR10S	6137	13039	7 900	10 000	1.40	58.45	1199.1
80BAR10S	7194	15399	7 400	9 300	1.93	76.44	1370.4
85BAR10S	73064	16074	7 000	8 900	2.14	78.68	1370.4
90BAR10S	95544	20795	6 600	8 300	2.64	80.93	1427.5
95BAR10S	9667	21694	6 300	8 000	2.91	80.93	1484.6
100BAR10S	9779	22481	6 000	7 600	3.08	83.18	1541.7
105BAR10S	11128	25853	5 700	7 200	3.83	85.43	1598.8
110BAR10S	12477	29450	5 400	6 800	4.65	87.68	1598.8
120BAR10S	12814	31698	5 000	6 400	4.99	87.68	1713
130BAR10S	16299	38667	4 600	5 800	7.41	87.68	1713

C_r = Dynamic Radial Load Rating
 C_{or} = Static Radial Load Rating

Introduction

Ball Bearings

Cylindrical Roller Bearings

Spherical Roller Bearings

Tapered Roller Bearings

Thrust Bearings

Split Pillow Blocks

Super Precision Bearings

Linear Motion

Rolling Mill Bearings

Engineering Section



Super Precision Thrust Angular Contact

BTR Series (Continued)

40° Contact Angle

Part Number	Basic Bearing Dimensions						Preferred Shoulder Dimensions		
	d		D		B		d _a min	D _b max	*r _b max
	mm	inch	mm	inch	mm	inch	inch	inch	inch
60BTR10S	60	2.3622	95	3.7402	16.5	0.6496	2.6378	3.5433	0.02362
65BTR10S	65	2.5591	100	3.9370	16.5	0.6496	2.8346	3.7402	0.02362
70BTR10S	70	2.7559	110	4.3307	18	0.7087	3.0315	4.1339	0.02362
75BTR10S	75	2.9528	115	4.5276	18	0.7087	3.2283	4.3307	0.02362
80BTR10S	80	3.1496	125	4.9213	20.25	0.7972	3.4252	4.7244	0.02362
85BTR10S	85	3.3465	130	5.1181	20.25	0.7972	3.6220	4.9213	0.02362
90BTR10S	90	3.5433	140	5.5118	22.5	0.8858	3.8976	5.2756	0.03937
95BTR10S	95	3.7402	145	5.7087	22.5	0.8858	4.0945	5.4724	0.03937
100BTR10S	100	3.9370	150	5.9055	22.5	0.8858	4.2913	5.6693	0.03937
105BTR10S	105	4.1339	160	6.2992	24.75	0.9744	4.5276	6.0630	0.03937
110BTR10S	110	4.3307	170	6.6929	27	1.0630	4.7244	6.4567	0.03937
120BTR10S	120	4.7244	180	7.0866	27	1.0630	5.1181	6.8504	0.03937
130BTR10S	130	5.1181	200	7.8740	31.5	1.2402	5.5118	7.6378	0.03937

Introduction

Ball Bearings

Cylindrical Roller Bearings

Spherical Roller Bearings

Tapered Roller Bearings

Thrust Bearings

Split Pillow Blocks

Super Precision Bearings

Linear Motion

Rolling Mill Bearings

Engineering Section

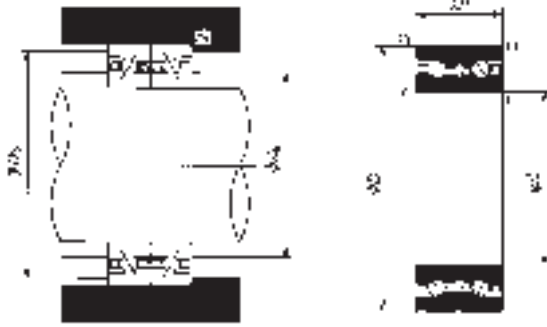

Common Options	
TR	: Phenolic cage
TY	: Polyamide cage
DU	: Duplex Universal
SU	: Single Universal
L	: Light Preload
M	: Medium Preload
H	: Heavy Preload
P4(PA7)	: ISO 4 (ABEC 7) Precision
P5(PA5)	: ISO 5 (ABEC 5) Precision

Part Number	Basic Load Ratings (lbs)		Limiting Speed Duplex (RPM)		Bearing Weight (Approx.) lbs	Preload Value Duplex (EL) lbs	Axial Rigidity Duplex (EL) lbs/.001 inch
	C_r	C_{or}	Grease	Oil			
60BTR10S	5036	9779	8 400	11 000	0.93	83.18	1884300
65BTR10S	5193	10566	7 900	10 400	0.99	87.68	1998500
70BTR10S	7194	14163	7 300	9 500	1.32	87.68	1998500
75BTR10S	7306	14725	6 900	9 000	1.40	89.92	2055600
80BTR10S	8543	17535	6 400	8 300	1.93	114.65	2284000
85BTR10S	8655	18322	6 100	8 000	2.14	116.90	2398200
90BTR10S	11240	23605	5 700	7 400	2.64	119.15	2455300
95BTR10S	11465	24729	5 500	7 100	2.91	123.64	2569500
100BTR10S	11578	25628	5 200	6 800	3.08	125.89	2626600
105BTR10S	13151	29450	5 000	6 500	3.84	128.14	2683700
110BTR10S	14837	33272	4 700	6 100	4.65	130.39	2797900
120BTR10S	15287	35969	4 400	5 700	4.99	137.13	2969200
130BTR10S	19334	43838	4 000	5 200	7.41	137.13	2969200

C_r = Dynamic Radial Load Rating
 C_{or} = Static Radial Load Rating

Introduction
 Ball Bearings
 Cylindrical Roller Bearings
 Spherical Roller Bearings
 Tapered Roller Bearings
 Thrust Bearings
 Split Pillow Blocks
 Super Precision Bearings
 Linear Motion
 Rolling Mill Bearings
 Engineering Section



Super Precision Cylindrical Roller Bearings

N 1000 Series
Single Row

Bearing Number	Basic Bearing Dimensions						Preferred Shoulder Dimensions			
	<i>d</i>		<i>D</i>		B		<i>r_a</i> (inch)	<i>d_a</i> (inch)	<i>D_b</i> (inch)	
	mm	mm	mm	inch	mm	inch	max	max	min	max
N1006	30	1.1811	55	2.1654	13	0.5118	0.0197	1.3780	2.0079	1.9291
N1007	35	1.3780	62	2.4409	14	0.5512	0.0197	1.5748	2.2835	2.2047
N1008	40	1.5748	68	2.6772	15	0.5906	0.0236	1.7717	2.5197	2.4409
N1009	45	1.7717	75	2.9528	16	0.6299	0.0236	1.9685	2.7953	2.6772
N1010	50	1.9685	80	3.1496	16	0.6299	0.0236	2.1654	2.9921	2.8740
N1011	55	2.1654	90	3.5433	18	0.7087	0.0394	2.4213	3.3465	3.2283
N1012	60	2.3622	95	3.7402	18	0.7087	0.0394	2.6181	3.5433	3.4252
N1013	65	2.5591	100	3.9370	18	0.7087	0.0394	2.8150	3.7402	3.6220
N1014	70	2.7559	110	4.3307	20	0.7874	0.0394	3.0118	4.1339	3.9764
N1015	75	2.9528	115	4.5276	20	0.7874	0.0394	3.2087	4.3307	4.1732
N1016	80	3.1496	125	4.9213	22	0.8661	0.0394	3.4055	4.7244	4.5276
N1017	85	3.3465	130	5.1181	22	0.8661	0.0394	3.6024	4.9213	4.7244
N1018	90	3.5433	140	5.5118	24	0.9449	0.0394	3.8583	5.2559	5.0787
N1019	95	3.7402	145	5.7087	24	0.9449	0.0394	4.0551	5.4528	5.2756
N1020	100	3.9370	150	5.9055	24	0.9449	0.0394	4.2520	5.6496	5.4724
N1021	105	4.1339	160	6.2992	26	1.0236	0.0394	4.4882	6.0433	5.7874
N1022	110	4.3307	170	6.6929	28	1.1024	0.0394	4.6850	6.4370	6.1811
N1024	120	4.7244	180	7.0866	28	1.1024	0.0394	5.0787	6.8307	6.5748
N1026	130	5.1181	200	7.8740	33	1.2992	0.0394	5.4724	7.6181	7.2441
N1028	140	5.5118	210	8.2677	33	1.2992	0.0394	5.8661	8.0118	7.6378

Application Data

Radial Internal Clearance — Table 10.37 on page 331
 Bearing Tolerances — Table 10.12 thru Table 10.16 on page 314-17
 Shaft & Housing Fits — Contact NSK Engineering

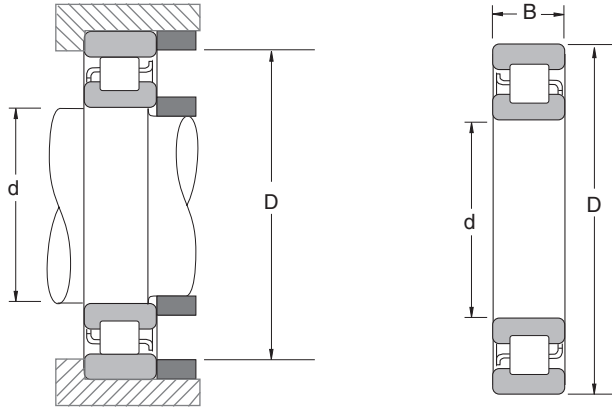

Common Options	
M	: One piece brass cage; inner ring guided
MB	: Split type brass cage; roller guided
MR	: Riveted brass cage; roller guided
T	: Polyamide cage; roller guided
KR	: Precision Tapered Bore 1:12
CCx	: Matched Clearance (9,1, . . .)
P4 (PA7)	: ISO 4 (ABEC7) Precision

Bearing Number	Basic Load Ratings (lbs)		Limiting Speeds (1000 RPM)		Bearing Weight (Approx.)
	C_r	C_{or}	Grease	Oil	lbs
N1006	4400	4400	20.0	22.0	0.29
N1007	5100	5200	18.0	20.0	0.40
N1008	6100	6500	16.0	18.0	0.49
N1009	7300	8000	14.0	16.0	0.60
N1010	7300	8200	13.0	15.0	0.64
N1011	8500	9800	12.0	13.0	0.96
N1012	9000	10900	11.0	12.0	1.02
N1013	9300	11500	10.0	12.0	1.10
N1014	13100	15900	9.5	11.0	1.49
N1015	13400	16800	9.0	10.0	1.58
N1016	16300	20400	8.5	9.5	2.09
N1017	16800	21500	8.0	9.0	2.19
N1018	19800	25800	7.5	8.5	2.86
N1019	20400	27100	7.1	8.0	3.01
N1020	20900	28200	6.7	7.5	3.15
N1021	24500	33500	6.3	7.1	3.98
N1022	29500	39000	6.0	6.7	4.95
N1024	31100	43000	5.6	6.3	5.24
N1026	38600	53500	5.3	5.6	7.94
N1028	39500	56000	4.8	5.3	8.38

C_r = Dynamic Radial Load Rating
 C_{or} = Static Radial Load Rating

Introduction
 Ball Bearings
 Cylindrical Roller Bearings
 Spherical Roller Bearings
 Tapered Roller Bearings
 Thrust Bearings
 Split Pillow Blocks
 Super Precision Bearings
 Linear Motion
 Rolling Mill Bearings
 Engineering Section

Super Precision Cylindrical Roller Bearings

NN 3000
Double Row



Bearing Number	Basic Bearing Dimensions						Preferred Shoulder Dimensions			
	<i>d</i>		<i>D</i>		B		<i>r_a</i> (inch)	<i>d_a</i> (inch)	<i>D_b</i> (inch)	
	mm	mm	mm	inch	mm	inch	max	max	min	max
NN3005	25	0.9843	47	1.8504	16	0.6299	0.0236	1.1417	1.6929	1.6535
NN3006	30	1.1811	55	2.1654	19	0.7480	0.0394	1.3780	1.9685	1.9685
NN3007	35	1.3780	62	2.4409	20	0.7874	0.0394	1.5748	2.2441	2.2047
NN3008	40	1.5748	68	2.6772	21	0.8268	0.0394	1.7717	2.4803	2.4409
NN3009	45	1.7717	75	2.9528	23	0.9055	0.0394	1.9685	2.7559	2.7165
NN3010	50	1.9685	80	3.1496	23	0.9055	0.0394	2.1654	2.9528	2.9134
NN3011	55	2.1654	90	3.5433	26	1.0236	0.0394	2.4213	3.2874	3.2677
NN3012	60	2.3622	95	3.7402	26	1.0236	0.0394	2.6181	3.4843	3.4646
NN3013	65	2.5591	100	3.9370	26	1.0236	0.0394	2.8150	3.6811	3.6614
NN3014	70	2.7559	110	4.3307	30	1.1811	0.0394	3.0118	4.0748	4.0157
NN3015	75	2.9528	115	4.5276	30	1.1811	0.0394	3.2087	4.2717	4.2126
NN3016	80	3.1496	125	4.9213	34	1.3386	0.0394	3.4055	4.6654	4.5276
NN3017	85	3.3465	130	5.1181	34	1.3386	0.0394	3.6024	4.8622	4.7244
NN3018	90	3.5433	140	5.5118	37	1.4567	0.0591	3.8583	5.1969	5.0787
NN3019	95	3.7402	145	5.7087	37	1.4567	0.0591	4.0551	5.3937	5.2756
NN3020	100	3.9370	150	5.9055	37	1.4567	0.0591	4.2520	5.5906	5.4724
NN3021	105	4.1339	160	6.2992	41	1.6142	0.0787	4.4882	5.9449	5.8268
NN3022	110	4.3307	170	6.6929	45	1.7717	0.0787	4.6850	6.3386	6.1811
NN3024	120	4.7244	180	7.0866	46	1.8110	0.0787	5.0787	6.7323	6.5748
NN3026	130	5.1181	200	7.8740	52	2.0472	0.0787	5.4724	7.5197	7.2835
NN3028	140	5.5118	210	8.2677	53	2.0866	0.0787	5.8661	7.9134	7.6772
NN3030	150	5.9055	225	8.8583	56	2.2047	0.0787	6.3386	8.4252	8.2283
NN3032	160	6.2992	240	9.4488	60	2.3622	0.0787	6.7323	9.0157	8.7402
NN3034	170	6.6929	260	10.2362	67	2.6378	0.0787	7.1260	9.8031	9.4094
NN3036	180	7.0866	280	11.0236	74	2.9134	0.0787	7.5197	10.5906	10.1575
NN3038	190	7.4803	290	11.4173	75	2.9528	0.0787	7.9134	10.9843	10.5512
NN3040	200	7.8740	310	12.2047	82	3.2283	0.0787	8.3071	11.7717	11.2205

Application Data

Radial Internal Clearance — Table 10.37 on page 331
 Bearing Tolerances — Table 10.12 thru Table 10.16 on page 314-17
 Shaft & Housing Fits — Contact NSK Engineering

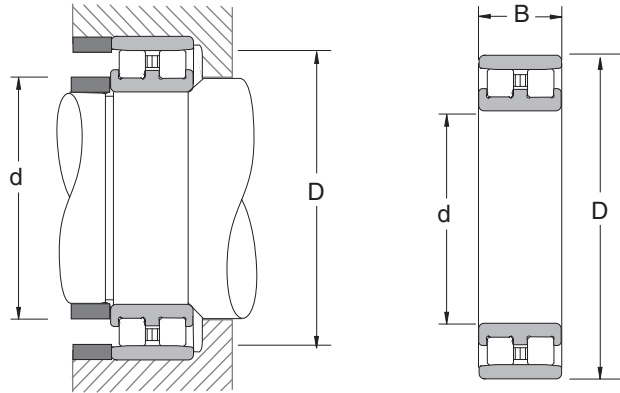

Common Options	
M	: One piece brass cage; inner ring guided
MB	: Split type brass cage; roller guided
MR	: Riveted brass cage; roller guided
T	: Polyamide cage; roller guided
KR	: Precision Tapered Bore 1:12
CCx	: Matched Clearance (9,1, . . .)
E44	: Lube Groove and Holes, Outer Ring
P4 (PA7)	: ISO 4 (ABEC7) Precision

Bearing Number	Basic Load Ratings (lbs)		Limiting Speeds (1000 RPM)		Bearing Weight (Approx.)
	C_r	C_{or}	Grease	Oil	lbs
NN3005	5800	6700	19.0	22.0	0.28
NN3006	6900	8400	16.0	19.0	0.43
NN3007	8800	11200	14.0	16.0	0.56
NN3008	9700	12500	13.0	15.0	0.67
NN3009	11700	15400	12.0	13.0	0.88
NN3010	11900	16300	11.0	12.0	0.95
NN3011	15500	21700	9.5	11.0	1.40
NN3012	16400	23800	9.0	10.0	1.50
NN3013	17300	26000	8.5	9.5	1.61
NN3014	21900	33300	8.0	9.0	2.31
NN3015	21800	34000	7.5	8.5	2.42
NN3016	26900	41900	6.7	8.0	3.37
NN3017	28200	45200	6.7	7.5	3.54
NN3018	32200	51100	6.0	7.1	4.53
NN3019	33700	55300	6.0	6.7	4.73
NN3020	35300	59500	5.6	6.3	4.95
NN3021	44500	73000	5.3	6.0	6.27
NN3022	51500	84000	5.0	5.6	8.10
NN3024	54000	91000	4.8	5.3	8.82
NN3026	64000	107000	4.3	4.8	12.87
NN3028	67200	116000	4.0	4.5	13.93
NN3030	75000	132000	3.8	4.3	16.92
NN3032	84000	149000	3.6	4.0	20.55
NN3034	101000	181000	3.2	3.8	28.16
NN3036	127000	225000	3.0	3.4	36.74
NN3038	133000	242000	3.0	3.4	38.94
NN3040	147000	262000	2.8	3.2	49.72

C_r = Dynamic Radial Load Rating
 C_{or} = Static Radial Load Rating

Introduction
 Ball Bearings
 Cylindrical Roller Bearings
 Spherical Roller Bearings
 Tapered Roller Bearings
 Thrust Bearings
 Split Pillow Blocks
 Super Precision Bearings
 Linear Motion
 Rolling Mill Bearings
 Engineering Section

Super Precision Cylindrical Roller Bearings

NN 3900
Double Row



Bearing Number	Basic Bearing Dimensions						Preferred Shoulder Dimensions			
	<i>d</i>		<i>D</i>		B		<i>r_a</i> (inch)	<i>d_a</i> (inch)	<i>D_b</i> (inch)	
	mm	inch	mm	inch	mm	inch	max	max	min	max
NN3920	100	3.9370	140	5.5118	30	1.1811	0.0394	4.1929	5.2559	5.1575
NN3921	105	4.1339	145	5.7087	30	1.1811	0.0394	4.3898	5.4528	5.3543
NN3922	110	4.3307	150	5.9055	30	1.1811	0.0394	4.5866	5.6496	5.5512
NN3924	120	4.7244	165	6.4961	34	1.3386	0.0394	4.9803	6.2402	6.0827
NN3926	130	5.1181	180	7.0866	37	1.4567	0.0591	5.4331	6.7717	6.6535
NN3928	140	5.5118	190	7.4803	37	1.4567	0.0591	5.8268	7.1654	7.0866
NN3930	150	5.9055	210	8.2677	45	1.7717	0.0787	6.2598	7.9134	7.7559
NN3932	160	6.2992	220	8.6614	45	1.7717	0.0787	6.6535	8.3071	8.1496
NN3934	170	6.6929	230	9.0551	45	1.7717	0.0787	7.0472	8.7008	8.5433
NN3936	180	7.0866	250	9.8425	52	2.0472	0.0787	7.4409	9.4882	9.2126
NN3938	190	7.4803	260	10.2362	52	2.0472	0.0787	7.8346	9.8819	9.6654
NN3940	200	7.8740	280	11.0236	60	2.3622	0.0787	8.3071	10.5906	10.2756
NN3944	220	8.6614	300	11.8110	60	2.3622	0.0787	9.0945	11.3780	11.0630
NN3948	240	9.4488	320	12.5984	60	2.3622	0.0787	9.8819	12.1654	11.8898
NN3952	260	10.2362	360	14.1732	75	2.9528	0.0787	10.6693	13.7402	13.3071
NN3956	280	11.0236	380	14.9606	75	2.9528	0.0787	11.4567	14.5276	14.0945

Application Data

Radial Internal Clearance — Table 10.37 on page 331
 Bearing Tolerances — Table 10.12 thru Table 10.16 on page 314-17
 Shaft & Housing Fits — Contact NSK Engineering

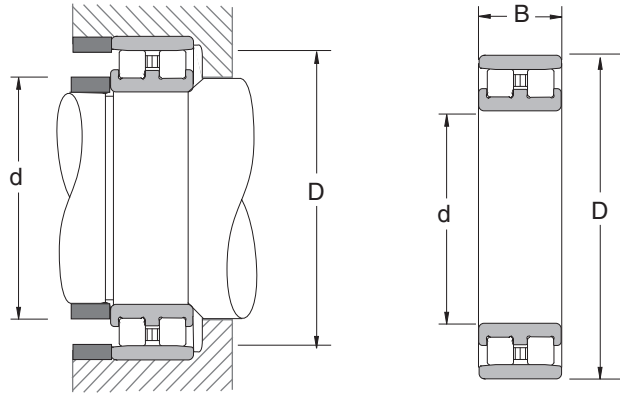

Common Options	
M	: One piece brass cage; inner ring guided
MB	: Split type brass cage; roller guided
MR	: Riveted brass cage; roller guided
T	: Polyamide cage; roller guided
KR	: Precision Tapered Bore 1:12
CCx	: Matched Clearance (9,1, . . .)
E44	: Lube Groove and Holes, Outer Ring
P4 (PA7)	: ISO 4 (ABEC7) Precision

Bearing Number	Basic Load Ratings (lbs)		Limiting Speeds (1000 RPM)		Bearing Weight (Approx.)
	C_r	C_{or}	Grease	Oil	lbs
NN3920	23800	40800	6.0	6.7	2.84
NN3921	24700	43600	5.6	6.3	3.30
NN3922	25800	46500	5.3	6.3	3.43
NN3924	30900	56000	5.0	5.6	4.40
NN3926	39000	72500	4.5	5.3	5.65
NN3928	45200	85000	4.3	4.8	6.07
NN3930	59000	109000	3.8	4.5	9.77
NN3932	61000	117000	3.6	4.3	11.33
NN3934	63000	123000	3.6	4.0	12.03
NN3936	76000	148000	3.2	3.8	15.71
NN3938	77000	152000	3.2	3.6	16.35
NN3940	93500	184000	3.0	3.4	23.10
NN3944	99000	202000	2.6	3.0	25.08
NN3948	104000	218000	2.6	2.8	26.62
NN3952	151000	311000	2.2	2.6	47.08
NN3956	155000	328000	2.2	2.4	49.94
NN3920	23800	40800	6.0	6.7	2.84
NN3921	24700	43600	5.6	6.3	3.30
NN3922	25800	46500	5.3	6.3	3.43
NN3924	30900	56000	5.0	5.6	4.40

C_r = Dynamic Radial Load Rating
 C_{or} = Static Radial Load Rating

Introduction

Ball Bearings

Cylindrical Roller Bearings

Spherical Roller Bearings

Tapered Roller Bearings

Thrust Bearings

Split Pillow Blocks

Super Precision Bearings

Linear Motion

Rolling Mill Bearings

Engineering Section



Ball Screw Support Bearings

Major Dimensions

Inch Series

Bearing Number	Boundary Dimensions						Ball Complement
	Bore Diameter d		Outside Diameter D		Width B		
	mm	inch	mm	inch	mm	inch	no. - inch
20 TAC 47XB	20.000	0.7874	47.0	1.8504	15.875	0.6250	15-1/4
23 TAC 62B	23.838	0.9385	62.0	2.4409	15.875	0.6250	21-1/4
38 TAC 72B	38.100	1.5000	72.0	2.8346	15.875	0.6250	24-1/4
44 TAC 76B	44.475	1.7510	76.2	3.0000	15.875	0.6250	26-1/4
57 TAC 90B	57.150	2.2500	90.0	3.5433	15.875	0.6250	32-1/4
76 TAC 110B	76.200	3.0000	110.0	4.3307	15.875	0.6250	41-1/4
101 TAC 145B	101.600	4.0000	145.0	5.7087	22.225	0.8750	37-3/8

Metric Series

Bearing Number	Boundary Dimensions						Ball Complement
	Bore Diameter d		Outside Diameter D		Width B		
	mm	inch	mm	inch	mm	inch	no. - inch
17 TAC 47B	17	0.6693	47	1.8504	15	0.5906	15-1/4
20 TAC 47B	20	0.7874	47	1.8504	15	0.5906	15-1/4
25 TAC 62B	25	0.9843	62	2.4409	15	0.5906	21-1/4
30 TAC 62B	30	1.1811	62	2.4409	15	0.5906	21-1/4
35 TAC 72B	35	1.3780	72	2.8346	15	0.5906	24-1/4
40 TAC 72B	40	1.5748	72	2.8346	15	0.5906	24-1/4
40 TAC 90B	40	1.5748	90	3.5433	20	0.7874	20-1/4
45 TAC 75B	45	1.7717	75	2.9528	15	0.5906	26-1/4
45 TAC 100B	45	1.7717	100	3.9370	20	0.7874	23-3/8
50 TAC 100B	50	1.9685	100	3.9370	20	0.7874	23-3/8
55 TAC 100B	55	2.1654	100	3.9370	20	0.7874	23-3/8
55 TAC 120B	55	2.1654	120	4.7244	20	0.7874	27-3/8
60 TAC 120B	60	2.1654	120	4.7244	20	0.7874	27-3/8

Ball Screw Support Bearings

Load Ratings

Inch Series

Bearing Number	Dynamic Axial Load Rating Ca						Limited Axial Capacity					
	One Row Loaded DF		Two Rows Loaded DFD•DFF•DT		Three Rows Loaded DFT•DTD		One Row Loaded DF		Two Rows Loaded DFD•DFF•DT		Three Rows Loaded DFT•DTD	
	daN	lbf	daN	lbf	daN	lbf	daN	lbf	daN	lbf	daN	lbf
20 TAC 47XB	2190	4920	3550	7980	4750	10700	2660	5980	5300	11900	7950	17900
23 TAC 62B	2850	6410	4650	10500	6150	13800	4050	9110	8150	18300	12200	27400
38 TAC 72B	3150	7080	5150	11600	6850	15400	5200	11700	10400	23400	15700	35300
44 TAC 76B	3300	7420	4350	12000	7100	16000	5700	12800	11400	25600	17000	38200
57 TAC 90B	3550	7980	5750	12900	7600	17100	6850	15400	13700	30800	20500	46100
76 TAC 110B	3900	8770	6300	14200	8350	18800	8650	19400	17300	38900	26000	58500
101 TAC 145B	7600	17100	12300	27700	16400	36900	16600	37300	33000	74200	50000	112000

Metric Series

Bearing Number	Dynamic Axial Load Rating Ca						Limited Axial Capacity					
	One Row Loaded DF		Two Rows Loaded DFD•DFF•DT		Three Rows Loaded DFT•DTD		One Row Loaded DF		Two Rows Loaded DFD•DFF•DT		Three Rows Loaded DFT•DTD	
	daN	lbf	daN	lbf	daN	lbf	daN	lbf	daN	lbf	daN	lbf
17 TAC 47B	2190	4920	3550	7980	4750	10700	2660	5980	5300	11900	7950	17900
20 TAC 47B	2190	4920	3550	7980	4750	10700	2660	5980	5300	11900	7950	17900
25 TAC 62B	2850	6410	4650	10500	6150	13800	4050	9110	8150	18300	12200	27400
30 TAC 62B	2920	6570	4750	10700	6300	14200	4300	9670	8600	19300	12900	29000
35 TAC 72B	3100	6970	5050	11400	6700	15100	5000	11200	10000	22500	15000	33700
40 TAC 72B	3150	7080	5150	11600	6850	15400	5200	11700	10400	23400	15700	35300
40 TAC 90B	5900	1330	9550	21500	12700	28600	8950	20100	17900	40200	26900	60500
45 TAC 75B	3300	7420	5350	12000	7100	16000	5700	12800	11400	25600	17000	38200
45 TAC 100B	6150	13800	10000	22500	13300	29900	9900	22300	19800	44500	29800	67000
50 TAC 100B	6300	14200	10200	22900	13600	30600	10400	23400	20800	46800	31000	69700
55 TAC 100B	6300	14200	10200	22900	13600	30600	10400	23400	20800	46800	31000	69700
55 TAC 120B	6750	15200	10900	24500	14500	32600	12300	27700	24600	55300	37000	83200
60 TAC 120B	6750	15200	10900	24500	14500	32600	12300	27700	24600	55300	37000	83200

Introduction

Ball Bearings

Cylindrical Roller Bearings

Spherical Roller Bearings

Tapered Roller Bearings

Thrust Bearings

Split Pillow Blocks

Super Precision Bearings

Linear Motion

Rolling Mill Bearings

Engineering Section

Ball Screw Support Bearings

Preloads, Spring Constants, and Starting Torque

Inch Series (Preload Symbol C11)

Bearing Number	Duplex Combinations (DF) Preload	Triplex Combinations (DFD) Preload	Quadruplex Combinations (DFF) Preload
	lbf	lbf	lbf
20 TAC 47XB	750	1000	1500
23 TAC 62B	1000	1350	2000
38 TAC 72B	1500	2100	3000
44 TAC 76B	1500	2100	3000
57 TAC 90B	1750	2300	3500
76 TAC 110B	2250	3000	4500
101 TAC 145B	3000	4100	6000

Metric Series (Preload Symbol C10)

Bearing Number	Duplex Combinations (DF) Preload	Triplex Combinations (DFD) Preload	Quadruplex Combinations (DFF) Preload
	lbf	lbf	lbf
17 TAC 47B	490	680	990
20 TAC 47B	490	680	990
25 TAC 62B	680	930	1390
30 TAC 62B	680	930	1390
35 TAC 72B	790	1080	1590
40 TAC 72B	790	1080	1590
40 TAC 90B	1010	1390	2050
45 TAC 75B	790	1080	1590
45 TAC 100B	1170	590	2300
50 TAC 100B	1170	1590	2300
55 TAC 100B	1170	1590	2300
55 TAC 120B	1390	1870	2750
60 TAC 120B	1390	1870	2750

Introduction

Ball Bearings

Cylindrical Roller Bearings

Spherical Roller Bearings

Tapered Roller Bearings

Thrust Bearings

Split Pillow Blocks

Super Precision Bearings

Linear Motion

Rolling Mill Bearings

Engineering Section

Table of Contents

Linear Motion

Introduction
 Ball Bearings
 Cylindrical Roller Bearings
 Spherical Roller Bearings
 Tapered Roller Bearings
 Thrust Bearings
 Split Pillow Blocks
 Super Precision Bearings
 Linear Motion
 Rolling Mill Bearings
 Engineering Section

INTRODUCTION

About NSK Linear Motion229

LINEAR GUIDES

Interchange231

Selection Tips233

LH Series234

LS Series244

LU Series252

LE Series253

LW Series254

Mounting and Lubrication255

NSK Grease Unit257

K1 Lubricating Unit262

BALL SCREWS

Precision Ground266

Rolled268

Ball Screw Support Bearings270

MONOCARRIERS

MCM Style275

MCH Style278

Introduction

ABOUT NSK LINEAR MOTION

- Linear Guides
- Linear Guide accessories
- Ball Screws
- Ball Screw accessories
- Monocarriers

LH Series: The four row face to face offset gothic arch design allows for: high load capacity, high resistance to impact loads, low friction and high accuracy. Sizes range from LH08 to LH65.

SH Series: This ball separation design allows for smoother operation while maintaining all the features of the LH design.

LS Series: Compact linear guides. The four row face to face design allows for: high load capacity, shock resistant design, low friction, and high accuracy. Sizes range from LS15 to LS35.

SS Series: This ball separation design allows for smoother operation while maintaining all the features of the LS design.

LW Series: Wide series linear guide suitable for single rail applications. Sizes range from LW17 to LW50.

LE Series: Wide series miniature linear guide suitable for single rail applications. Product is offered standard in stainless steel. Sizes range from LE05 to LE15.

LU Series: Miniature series linear guide allows for single rail applications. Sizes range from LU05 to LU15. The LU series is available in both carbon and stainless steel.

LY Series: Custom series linear guide. The four row back to back design allows for greater stiffness and rigidity. This series is ideal for machine tool applications. Size range: LY15 to LY65.

LA Series: Custom series linear guide. The six row design is also ideal for machine tool applications, where a higher degree of stiffness and rigidity are required. Size range: LA25 up to LA65.

TS Series: "Translide", cost effective linear guide, utilizing a rolled rail concept. Product comes standard with high performance and the K1 lubrication system. Size range: TS15 up to TS35.

Linear Guide Accessories: K1 Lubrication system is available on all of NSK's linear guide product offering. Additionally, we offer rail caps, high performance seals, double seals & scrapers and lubrication adapters.

Ball Screws

Standard Precision Ground Ball Screws: NSK offers a complete line of standard ground ball screws. Ranging from a 4mm OD up to 50mm OD, with varying leads. Standard ground screw leads are available in metric and inch designs.

"A" Series Ground Ball Screws: Standard ground screws with finished shaft ends. The ends have been finished to accommodate the NSK ball screw support unit.

"S" Series Ground Screws: Standard ground screws with unfinished shaft ends. These ends have been annealed to allow the user to finish the ends to their specifications.

Rolled Ball Screws: NSK offers a line of metric series rolled ball screws. Nuts and shafts are interchangeable. Rolled screws are offered from a 10mm OD up to 50-mm OD with varying leads. Shafts are available up to 4 meters in length.

Custom Precision Ground Ball Screws: In addition to the standard series ball screws, NSK can produce custom ball screws per custom specification.

Ball Screw Accessories: NSK offers a complete line of ball screw support unit kits. These kits range in size from a 6mm OD up to a 40mm OD. These kits come complete with the radial bearings, bearing housing, lock nut, washer, and set screw. These units are available in both a square and round configuration. The K1 lubrication system is available on some of the standard series ground screws. Please contact your local NSK representative for additional details.

Monocarriers

Monocarriers: Combine a precision ground ball screw, ball screw support unit, and linear guide into a single axis actuator. All Monocarriers come installed with K1 lubrication kits. Additionally, all units come standard with a corrosion resistant coating. Two-accuracy class' available: standard "P" grade, or the custom, "H" grade.

MCM Series: Single axis unit available up to 1000 mm strokes lengths. Offered in the following widths: MCM03, MCM05, MCM06, MCM08, MCM10. Offered in a single or double slider configuration.

MCH Series: Single axis high rigidity unit, with installed motor bracket. Available in the following widths: MCH06, MCH09, MCM10. The MCH10 is available up to 1,800mm stroke.

Monocarrier Accessories: Include Motor brackets, sensors, and covers.

Introduction

Ball Bearings

Cylindrical Roller Bearings

Spherical Roller Bearings

Tapered Roller Bearings

Thrust Bearings

Split Pillow Blocks

Super Precision Bearings

Linear Motion

Rolling Mill Bearings

Engineering Section

Interchange — Linear Guide (LH & LS Series)



Linear Guides are designed for high precision motion and control applications. They provide greater rigidity and higher load capacity than shaft and bushing designs.

Some of the industries served - machine tool, robotics, medical and aerospace - require smooth travel and high accuracy.

DESCRIPTION	NSK			THK			THOMSON								
	LAH	20	AN	Z	HSR	20	R	CG	20	CE					
CARRIAGE PART NUMBER	1	2	3	7	1	2	3	1	2	3					
RAIL PART NUMBER	L1H	20	XXXX		HSR	20+	XXXXL	RG	20 N	LXXXX					
	1	2	4		1	2	4	1	2	4					
ASSEMBLY PART NUMBER	LH	20	XXXX	AN	2	PC	Z	HSR	20	R	2	SS	C1	+XXXXL	P
	1	2	4	3	5	6	7	1	2	3	5	8	7	4	6

The competitive manufacturers are provided for a convenient source of unit substitution. They can be considered interchangeable in most instances, but for special applications, please consult NSK Engineering. NSK assumes no liability with respect to errors or omissions.

NSK	1-Linear Guide Series	
	THK	THOMSON
LH LS	HSR SR	CG
NSK	2-Linear Guide Size	
	THK	THOMSON
LH15 LH20 LH25 LH30 LH35 LH45 LH55 LH65 LS15 LS20 LS25 LS30 LS35	HSR15 HSR20 HSR25 HSR30 HSR35 HSR45 HSR55 HSR65 SR15 SR20 SR25 SR30 SR35	CG20 CG25 CG30 CG35 CG45 CG55
NSK	3-Linear Guide Carriage Styles LH Series	
	THK	THOMSON
LAH##AN LAH##BN LAH##EM LAH##GM	HSR##TR/TRX/CR/R HSR##HTR/HR/LR HSR##TA/CA/A HSR##TB/CB/B HSR##HTA/HA/LA HTB/HB/LB	CG##CE CG##DE CGAA CG##BA
*Thomson NOT DIMENSIONALLY EQUIVALENT, MAY NEED SHIM		
NSK	LS Series	
	THK	THOMSON
LAS##FL LAS##AL LAS##KL LAS##CL	SR##TB/TBY SR##TX/W/WY SR##SB/SBY SR##SX/VVY	
INTERCHANGE = LAH or LAS FOLLOWED BY SERIES# + CARRIAGE STYLE		

NSK	4-Linear Guide Rail Length mm	
	THK	THOMSON
L1H##XXXX L1S##XXXX	HSR##+XXXXL HSR##+XXXXL	RG##NLXXXX
	5-Carriages Per Rail Number following carriage style = number of carriages per rail	
NSK	6-Accuracy Class	
	THK	THOMSON
PC P6 P5 P4 P3	H P SP UP	N H P S U
NSK	7-Preload (assemblies only)	
	THK	THOMSON
T Z 2 3 4	C1 C1 C0 C0	A B B C C
NSK	7-Preload (carriage only)	
	THK	THOMSON
Z	C1	B
NSK	8-Seals	
	THK	THOMSON
Standard with side and bottom seals. Double seals and scrapers available.	SS-end/bottom UU-end ZZ-end/bottom/scrapper DD-double/bottom KK-double/bottom/scrapper	LDS ZZ DD KK

Interchange — Linear Guide (LU, LE, & LW Series)

DESCRIPTION	INTERCHANGE																			
	NSK				THK				THOMSON											
CARRIAGE PART NUMBER	LAU	15	AL		RSR	15	M		CD	15	AA									
	LAE	12	AR		RSR	12	W		1	2	3									
	LAW	17	EL		HRW	17	CA		1	2	3									
		1	2	3		1	2	3		1	2	3								
RAIL PART NUMBER	L1U	15	XXXX		RSR	15	+XXXXL		RD	15	LXXXX									
	L1E	12	XXXX		RSR	12W	+XXXXL													
	L1W	17	XXXX		HRW	17	+XXXXL		1	2	4									
		1	2	4		1	2	4		1	2	4								
ASSEMBLY PART NUMBER	LU	15	XXXX	AL	2	PC	ZT	2	RSR	15	R	UU	C1	+XXXXL	P					
	LE	12	XXXX	AR	2	PC	ZT	2	RSR	12	W	UU	C1	+XXXXL	P					
		1	2	4	3	5	6	7	5	1	2	3	8	7	4	6				
	LW	17	XXXX	EL	2	PC	ZT	HRW	17	CA	2	UU	C1	+XXXXL	P					
		1	2	4	3	5	6	7	1	2	3	5	8	7	4	6				

The competitive manufacturers are provided for a convenient source of unit substitution. They can be considered interchangeable in most instances, but for special applications, please consult NSK Engineering. NSK assumes no liability with respect to errors or omissions.

NSK	1-Linear Guide Series	
	THK	THOMSON
LU	RSR	CD
LE	RSR W	
LW	HRW	
NSK	2-Linear Guide Size	
	THK	THOMSON
LU05	RSR07	
LU07	RSR09	
LU09	RSR12	CD10
LU12	RSR15	CD15
LU15	RSR09W	CD20
LE09	RSR12W	
LE12	RSR15W	
LE15	HRW17	
LW17		HRW21
LW21		
LW27	HRW27	
LW35	HRW35	
LW50	HRW50	
NSK	3-Linear Guide Carriage Styles LU & LE Series	
	THK	THOMSON
LAU/LAE##AR, AL	RSR/RSRW##M,KM,WM,WVM	CD##AA
LAU/LAE##TR, TL	RSR/RSRW##VM,M,KM	
LAU/LAE##BL, UL	RSR/RSRW##WN,N	
LAU/LAE##CL, SL		
LS Series		
NSK	THK	THOMSON
LAW##EL	HRW##CA	

INTERCHANGE = LAU, LAE, LAW FOLLOWED BY SERIES # + CARRIAGE STYLE

NSK	4-Linear Guide Rail Length mm	
	THK	THOMSON
L1U ## XXXX	RSR##+XXXXL	RD##LXXXX
L1E ## XXXX	RSR##W+XXXXL	
L1W ## XXXX	HRW##+XXXXL	
5-Carriages Per Rail Number following carriage style = number of carriages per rail		
NSK	6-Accuracy Class	
	THK	THOMSON
PC		N
P6	H	H
P5	P	P
P4	SP	S
P3	UP	U
NSK	7-Preload (assemblies only)	
	THK	THOMSON
T		A
Z	C1	B
2	C1	B
3	C0	C
4	C0	C
NSK	7-Preload (carriage only)	
	THK	THOMSON
Z	C1	B
NSK	8-Seals	
	THK	THOMSON
Standard with side and bottom seals. Double seals and scrapers available.	SS-end/bottom UU-end ZZ-end/bottom/scrapper DD-double/bottom KK-double/bottom/scrapper	LDS ZZ DD KK

Linear Guide Product Selection Tips

To help in the selection of linear guides, NSK has come up with a series of questions that need to be asked in order to determine the appropriate NSK product.

- What is the application?
- Who is the competition?
- What is the NSK or competitor parts number?
- What type of carriage or bearing style is needed for this application: Tapped or Through Hole, Square or Flange style?
- What is the rail length required for this application?
- How many carriages or bearings are needed per rail?
- Are there any special accuracy and preload requirements?
- What are the loading conditions of the application? Please provide both Static & Dynamic loads.
- What are the delivery requirements?
- What is the G dimension of rail?
- Can you provide us with a drawing of the part to be purchased?
- Lubrication Method - Is the K1 lubrication system of interest for this application?

G Dimension Information: In order to properly cut linear guide rail to the customer's requirements, it is necessary to ask the customer for the G dimension. The G dimension is the dimension from the end of the rail length to the center of the first bolt-hole. In certain applications, we will need to know the G dimension for both ends of the rail. See the illustration below:

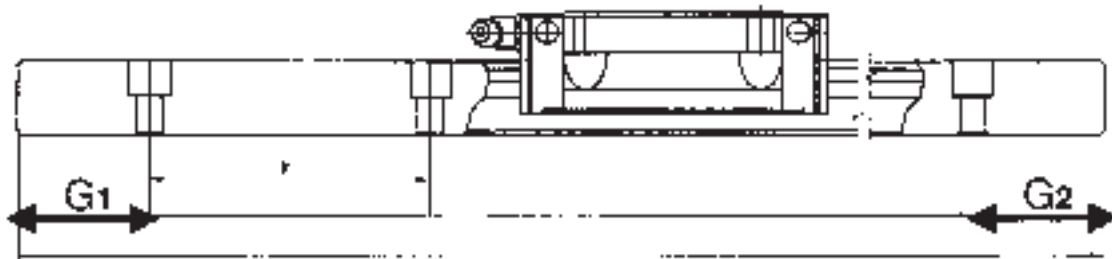

Linear Guides

LH Series
Identification Number Ball Slide

Ball Slide (Stocked item)

LAH 25 AN C Z - K

Ball Slide Type

Size No.

AN: Square - Standard
BN: Square - Long
EM: Flanged (Tapped & Thru hole) Standard
GM: Flanged (Tapped & Thru hole) Long

Style

Material Code

C: Standard carbon steel (may also be Blank)
S: Stainless Steel (standard for LU and LE series)
D: Carbon steel + Raydent coating
H: Stainless steel + Raydent coating
A: Carbon Steel + Armoloy
B: Stainless Steel + Armoloy

No code: No special accessories and fluoride black chrome plating
K: One K1 Lubrication Unit each side
K2: Two K1 Lubrication Units each side
D: Double Seals each side
P: Protector Plate each side

No code: Clearance type
Z: Preloaded type

Flanged Type — Low Height Type — with Tapped & Thru Holes — EM (High Load)
GM (Ultra High Load)
Square Type — High Type — LH-AN (High Load), LH-BN (Ultra High Load)

Fig.-1 LH-AN, LH-BN TYPE

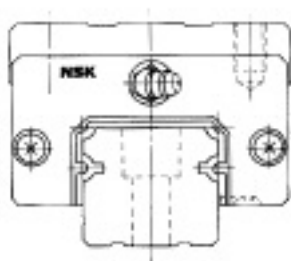
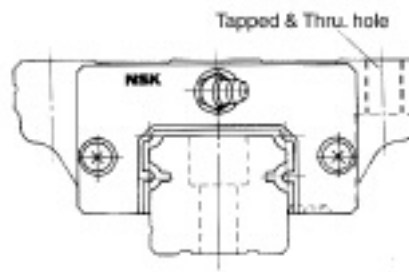

Fig.-2 LH-EM, LH-GM TYPE



Internal Clearance and Preload

The internal clearance refers to the amount of movement of the ball slide, when moved up and down with the rail fixed. The amount of preload is specified by size as follows.

Table 1

Unit: μm

Size	#15	#20 #25	#30 #35 #45	#55 #65
Clearance	15~4	15~5		
Preloaded	0~4	0~5	0~7	0~9

Accuracy Standard

The accuracy standard of the NSK “High Load Capacity LH-Series” is shown in Table 1. With high-accuracy control of individual rail size and interchangeability, the accuracy of Table 1 can be maintained sufficiently even after addition or replacement of the ball slide.

Table 1 Tolerances Unit : μm

Tolerances (See Fig. 4 for Symbols)		Model No. LH	
		15, 20, 25, 30, 35	45,55,65
Clearance Type	Overall Height, H	± 20	± 30
	Lateral Width, W_2	± 30	± 35
Preload Type	Overall Height, H	± 20	± 30
	Lateral Width, W_2	± 30	± 35
Running Parallelism of Face C to Face A		Refer to Fig. 3	
Running Parallelism of Face D to Face B			

W_2 is applicable to the reference side only. Note: during installation the reference side is indicated by a line provided on the side of ball slide and rail. (See Fig. 4)

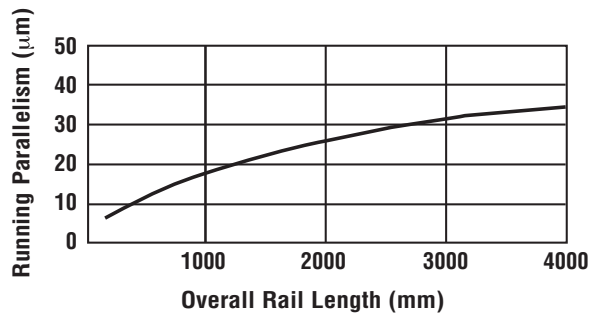

Fig. 3 Running Parallelism

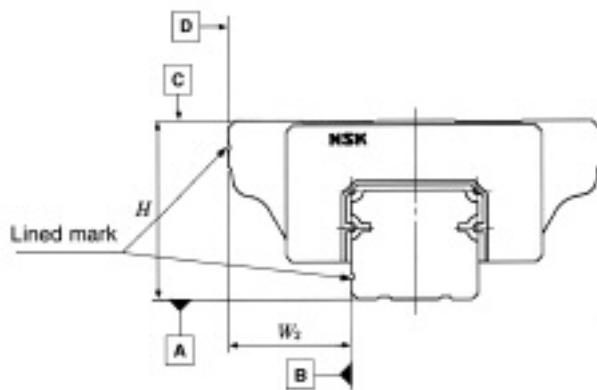

Fig. 4 Accuracy Standard

Load Rating and Life

The LH-Series is based on a design applying load from above. Therefore the dimension table shows the basic dynamic load rating C and basic static load rating C_0 for the downward direction. If the load is applied laterally or upward refer to values in Table 2.

Table 2 Basic Load Rating Correction for Direction

Load Direction	Basic Dynamic Load Rating	Basic Static Load Rating
Downward	C	C_0
Upward	C	$0.75C_0$
Laterally	$0.88C$	$0.63C_0$

Estimate the life of linear guides using the equation below.

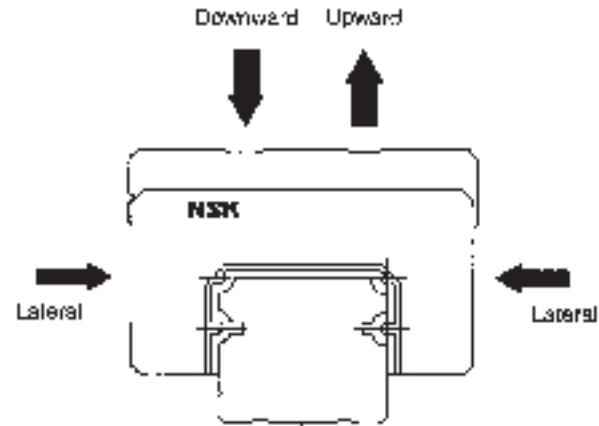

$$L = 50 \left(\frac{C}{f_w \cdot F} \right)^3$$

where,

- L : Rated fatigue life(km)
- C : Basic dynamic load rating (kgf)
- F : Load to a ball slide (kgf)
(Dynamic equivalent load)
- f_w : Load factor
 - $f_w = 1.0 \sim 1.2$ (Smooth condition)
 - $f_w = 1.2 \sim 1.5$ (Normal condition)
 - $f_w = 1.5 \sim 3.0$ (With shock or vibration)

Square Type

LAH-AN/ANZ
LAH-BN/BNZ

Linear Guides

LH Series
Ball Slide Dimension Table

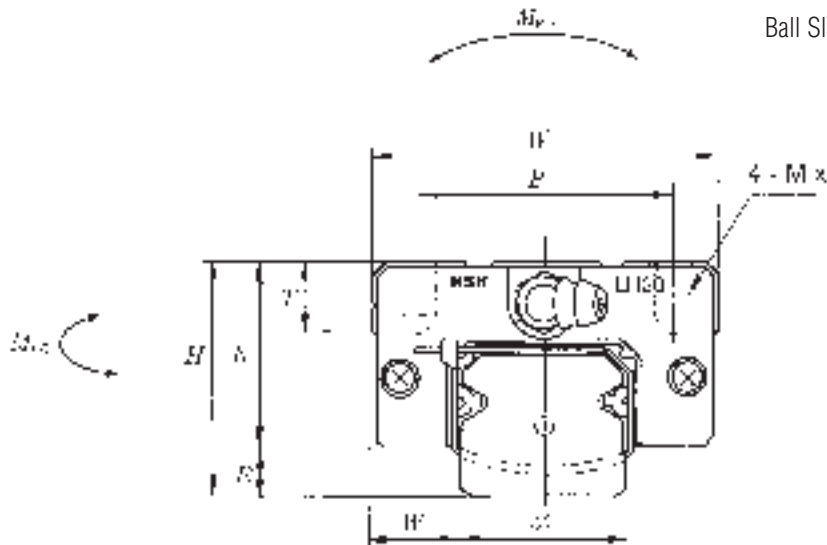

Model No.	Ass'y Dimensions			Ball Slide Dimensions								
	H	E	W ₂	W	B	L	L ₁	J	J ₁	K	T	M x l
LAH15 AN/ANZ LAH15 BN/BNZ	28	4.6	9.5	34	26	55	39	26	6.5	23.4	8	M 4 x 6
LAH20 AN/ANZ LAH20 BN/BNZ	30	5	12	44	32	69.8 91.8	50 72	36 50	7 11	25	12	M 5 x 6
LAH25 AN/ANZ LAH25 BN/BNZ	40	7	12.5	48	35	79 107	58 86	35 50	11.5 18	33	12	M 6 x 9
LAH30 AN/ANZ LAH30 BN/BNZ	45	9	16	60	40	85.6 124.6	59 98	40 60	9.5 19	36	14	M 8 x 10
LAH35 AN/ANZ LAH35 BN/BNZ	55	9.5	18	70	50	109 143	80 114	50 72	15 21	45.5	15	M 8 x 12
LAH45 AN/ANZ LAH45 BN/BNZ	70	14	20.5	86	60	139 171	105 137	60 80	22.5 28.5	56	17	M10 x 17
LAH55 AN/ANZ LAH55 BN/BNZ	80	15	23.5	100	75	163 201	126 164	75 95	25.5 34.5	65	18	M12 x 18
LAH65 AN/ANZ LAH65 BN/BNZ	90	16	31.5	126	76	193 253	147 207	70 120	38.5 48.5	74	23	M16 x 20

Note: W₁ rail dimensions are on Page 242.

Introduction

Ball Bearings

Cylindrical Roller Bearings

Spherical Roller Bearings

Tapered Roller Bearings

Thrust Bearings

Split Pillow Blocks

Super Precision Bearings

Linear Motion

Rolling Mill Bearings

Engineering Section

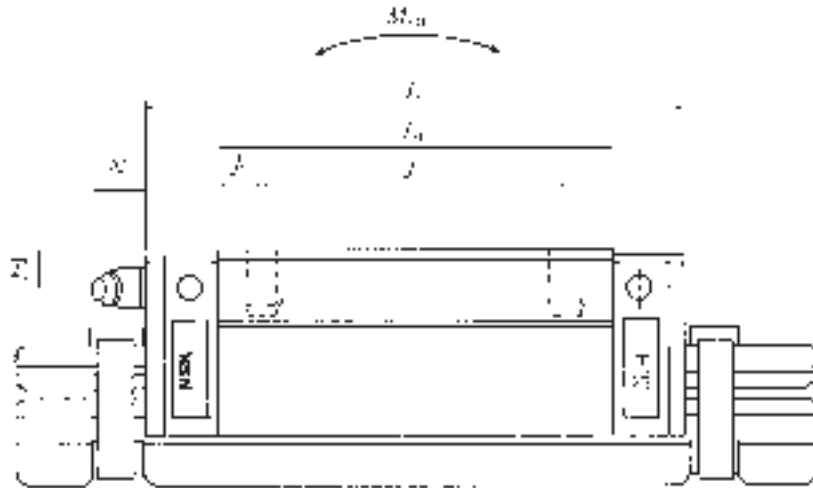

Unit : mm

Grease Fitting			Basic Load Ratings					Weight (kgf)	Model No.
Mounting Hole Thread Spec.	T_1	N	Dynamic C (kgf)	Static C_0 (kgf)	Static Moment (kgf•m)				
					M_{R0}	M_{P0}	M_{Y0}		
ø3 (thru hole)	8.5	3.3	1100 1490	2110 3260	10	8	8	0.18	LAH15 AN/ANZ LAH15 BN/BNZ
M6x0.75	5	11	1770 2400	3310 5150	22 31	18 35	18 35	0.33 0.48	LAH20 AN/ANZ LAH20 BN/BNZ
M6x0.75	10	11	2610 3520	4690 7240	36 48	32 54	31 53	0.55 0.82	LAH25 AN/ANZ LAH25 BN/BNZ
M6x0.75	10	11	3160 4690	5250 9330	50 80	36 86	36 85	0.77 1.3	LAH30 AN/ANZ LAH30 BN/BNZ
M6x0.75	15	11	4840 6270	8210 11930	96 136	75 144	73 141	1.5 2.1	LAH35 AN/ANZ LAH35 BN/BNZ
PT1/8	20	13	8260 10090	14280 19070	216 264	170 251	168 248	3 3.9	LAH45 AN/ANZ LAH45 BN/BNZ
PT1/8	21	13	12140 14890	20190 26920	367 449	293 435	288 426	4.7 6.1	LAH55 AN/ANZ LAH55 BN/BNZ
PT1/8	19	13	18460 23960	28650 41810	629 834	495 850	484 830	7.7 10.8	LAH65 AN/ANZ LAH65 BN/BNZ

Introduction

Ball Bearings

Cylindrical Roller Bearings

Spherical Roller Bearings

Tapered Roller Bearings

Thrust Bearings

Split Pillow Blocks

Super Precision Bearings

Linear Motion

Rolling Mill Bearings

Engineering Section

Flange Type

LAH-EL/ELZ
LAH-FL/FLZ

Linear Guides

LH Series
Ball Slide Dimension Table

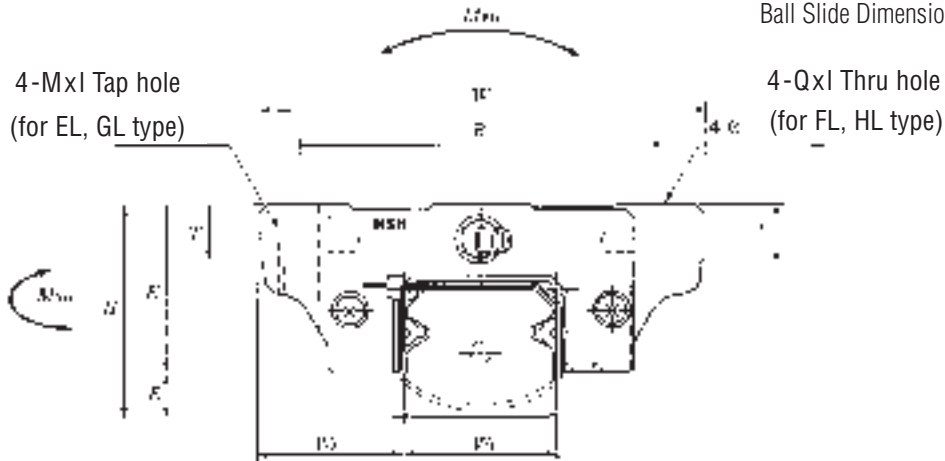

Note: EM/EMZ and GM/GMZ is a combination of Tapped hole and Thru hole.

Model No.	Ass'y Dimensions			Ball Slide Dimensions									
	H	E	W ₂	W	B	L	L ₁	J	J ₁	K	T	M x I Q x I	Bolt Size Through Hole Q
LAH15 EL/ELZ FL/FLZ GL/GLZ HL/HLZ	24	4.6	16	47	38 x 30	55	39	4.5	19.4	8	M5 x 8	Ø4.4 x 8	M4
LAH20 EL/ELZ FL/FLZ GL/GLZ HL/HLZ	30	5	21.5	63	53 x 40	69.8	50	5	25	10	M6 x 10	Ø5.3 x 10	M5
LAH25 EL/ELZ FL/FLZ GL/GLZ HL/HLZ	36	7	23.5	70	57 x 45	79	58	6.5	29	11	M8 x 10	Ø6.8 x 10	M6
LAH30 EL/ELZ FL/FLZ GL/GLZ HL/HLZ	42	9	31	90	72 x 52	98.6	72	10	33	11	M10 x 12	Ø8.6 x 12	M8
LAH35 EL/ELZ FL/FLZ GL/GLZ HL/HLZ	48	9.5	33	100	82 x 62	109	80	9	38.5	12	M10 c 13	Ø8.6 x 13	M8
LAH45 EL/ELZ FL/FLZ GL/GLZ HL/HLZ	60	14	37.5	120	100 x 80	139	105	12.5	46	13	M12 x 15	Ø10.5 x 15	M10
LAH55 EL/ELZ FL/FLZ GL/GLZ HL/HLZ	70	15	43.5	140	116 x 95	163	126	15.5	55	15	M14 x 18	Ø12.5 x 18	M12
LAH65 EL/ELZ FL/FLZ GL/GLZ HL/HLZ	90	16	53.5	170	142 x 110	193	147	18.5	74	23	M16 x 24	Ø14.6 x 24	M14

Note: W₁ rail dimensions are on Page 242.

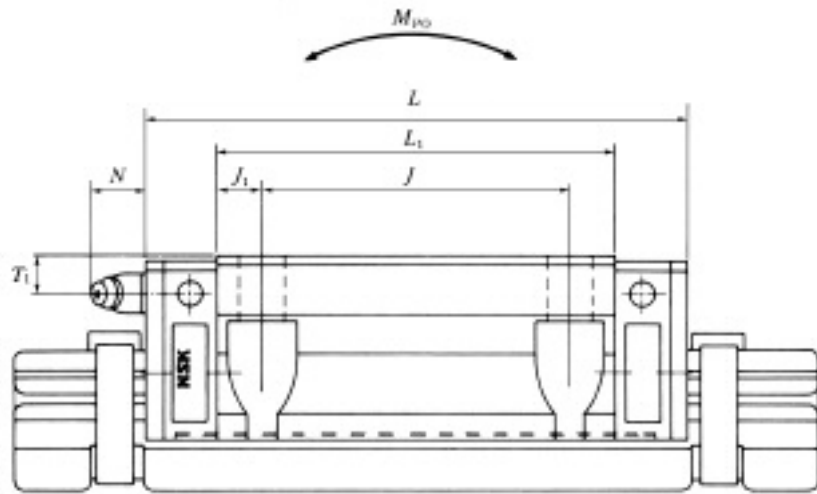

Unit : mm

Grease Fitting			Basic Load Ratings					Weight (kgf)	Model No.	
Mounting Hole Thread Spec.	T_1	N	Dynamic C (kgf)	Static C_0 (kgf)	Static Moment (kgf·m)					
					M_{RO}	M_{PO}	M_{YO}			
Ø3 (thru hole)	4.5	3.3	850	2110	10	8	8	0.17	LAH15	EL/ELZ FL/FLZ
			1490	3260	15	18	18	0.25	LAH15	GL/GLZ HL/HLZ
M6x0.75	5	11	1770	3310	22	18	18	0.45	LAH20	EL/ELZ FL/FLZ
			2400	5150	31	35	35	0.65	LAH20	GL/GLZ HL/HLZ
M6x0.75	6	11	2610	4690	36	32	31	0.63	LAH25	EL/ELZ FL/FLZ
			3520	7240	48	54	53	0.93	LAH25	GL/GLZ HL/HLZ
M6x0.75	7	11	3160	5250	60	50	49	1.2	LAH30	EL/ELZ FL/FLZ
			4690	9330	80	86	85	1.6	LAH30	GL/GLZ HL/HLZ
M6x0.75	8	11	4840	8210	96	75	73	1.7	LAH35	EL/ELZ FL/FLZ
			6270	11930	136	144	141	2.4	LAH35	GL/GLZ HL/HLZ
PT1/8	10	13	8260	14280	216	170	168	3	LAH45	EL/ELZ FL/FLZ
			10090	19070	264	251	248	3.9	LAH45	GL/GLZ HL/HLZ
PT1/8	11	13	12140	20190	367	293	288	5	LAH55	EL/ELZ FL/FLZ
			14890	26920	449	435	426	6.5	LAH55	GL/GLZ HL/HLZ
PT1/8	19	13	18460	28650	629	495	484	10	LAH65	EL/ELZ FL/FLZ
			23960	41810	834	850	830	14.1	LAH65	GL/GLZ HL/HLZ

Introduction

Ball Bearings

Cylindrical Roller Bearings

Spherical Roller Bearings

Tapered Roller Bearings

Thrust Bearings

Split Pillow Blocks

Super Precision Bearings

Linear Motion

Rolling Mill Bearings

Engineering Section

Flange Type

LAH-EM/EMZ
(formerly EL-ELZ-90)
LAH-GM/GMZ
(formerly GL-GLZ-90)

Linear Guides

LH Series
Ball Slide Dimension Table

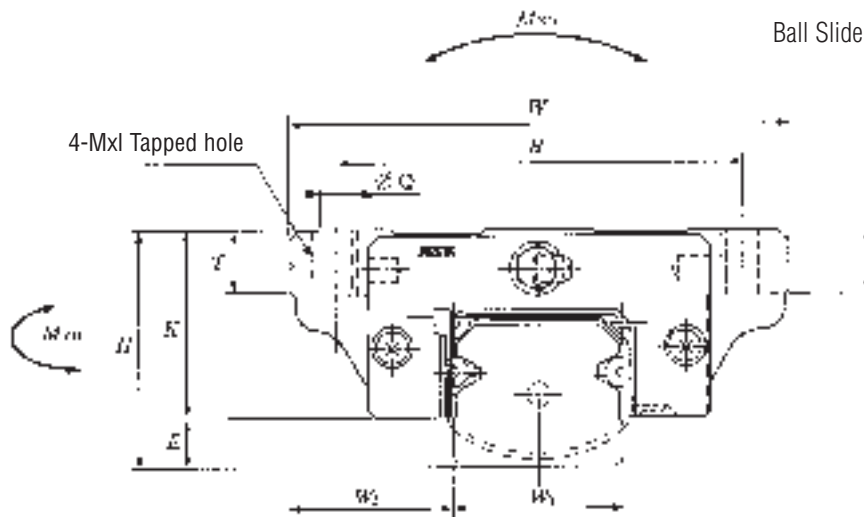

Note: EM/EMZ and GM/GMZ is a combination of Tapped hole and Thru hole.

Model No.	Ass'y Dimensions			Ball Slide Dimensions									
	H	E	W ₂	W	B x J	L	L ₁	J ₁	K	T	M x l	Ø Q x l	Bolt Size Through Hole Q
LAH15 EM/EMZ GM/GMZ	24	4.6	16	47	38 x 30	55 74	39 58	4.5 14	19.4	8	M5 x 8	Ø4.4 x 8	M4
LAH20 EM/EMZ GM/GMZ	30	5	21.5	63	53 x 40	69.8 91.8	50 72	5 16	25	10	M6 x 10	Ø5.3 x 10	M5
LAH25 EM/EMZ GM/GMZ	36	7	23.5	70	57 x 45	79 107	58 86	6.5 20.5	29	11	M8 x 10	Ø6.8 x 10	M6
LAH30 EM/EMZ GM/GMZ	42	9	31	90	72 x 52	98.6 124.6	72 98	10 23	33	11	M10 x 12	Ø8.6 x 12	M8
LAH35 EM/EMZ GM/GMZ	48	9.5	33	100	82 x 62	109 143	80 114	9 26	38.5	12	M10 x 13	Ø8.6 x 13	M8
LAH45 EM/EMZ GM/GMZ	60	14	37.5	120	100 x 80	139 171	105 137	12.5 28.5	46	13	M12 x 15	Ø10.5 x 15	M10
LAH55 EM/EMZ GM/GMZ	70	15	43.5	140	116 x 95	163 201	126 164	15.5 34.5	55	15	M14 x 18	Ø12.5 x 18	M12
LAH65 EM/EMZ GM/GMZ	90	16	53.5	170	142 x 110	193 253	147 207	18.5 48.5	74	23	M16 x 24	Ø14.6 x 24	M14

Note: W₁ rail dimensions are on Page 242.

Introduction

Ball Bearings

Cylindrical Roller Bearings

Spherical Roller Bearings

Tapered Roller Bearings

Thrust Bearings

Split Pillow Blocks

Super Precision Bearings

Linear Motion

Rolling Mill Bearings

Engineering Section

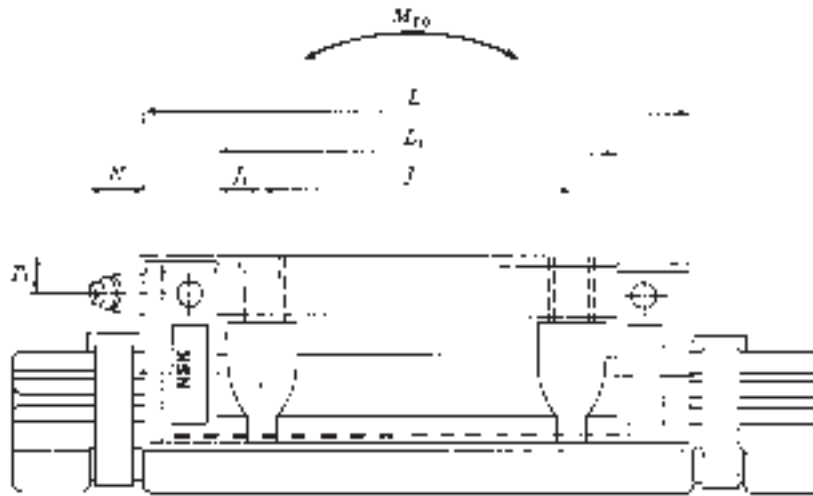

Unit : mm

Grease Fitting			Basic Load Ratings					Weight (kgf)	Model No.	
Mounting Hole Thread Spec.	T_1	N	Dynamic C (kgf)	Static C_0 (kgf)	Static Moment (kgf•m)					
					M_{RO}	M_{PO}	M_{YO}			
Ø3 (thru hole)	4.5	3.3	1100	2110	10	8	8	0.17	LAH15	EM/EMZ GM/GMZ
			1490	3260	15	18	18	0.25		
M6x0.75	5	11	1770	3310	22	18	18	0.45	LAH20	EM/EMZ GM/GMZ
			2400	5150	31	35	35	0.65		
M6x0.75	6	11	2610	4690	36	32	31	0.63	LAH25	EM/EMZ GM/GMZ
			3520	7240	48	54	53	0.93		
M6x0.75	7	11	3160	5250	60	50	49	1.2	LAH30	EM/EMZ GM/GMZ
			4690	9330	80	86	85	1.6		
M6x0.75	8	11.5	4840	8210	96	75	73	1.7	LAH35	EM/EMZ GM/GMZ
			6270	11930	136	144	141	2.4		
PT1/8	10	13	8260	14280	216	170	168	3	LAH45	EM/EMZ GM/GMZ
			10090	19070	264	251	248	3.9		
PT1/8	11	13	12140	20190	367	293	288	5	LAH55	EM/EMZ GM/GMZ
			14890	26920	449	435	426	6.5		
PT1/8	19	13	18460	28650	629	495	484	10	LAH65	EM/EMZ GM/GMZ
			23960	41810	834	850	830	14.1		

Introduction

Ball Bearings

Cylindrical Roller Bearings

Spherical Roller Bearings

Tapered Roller Bearings

Thrust Bearings

Split Pillow Blocks

Super Precision Bearings

Linear Motion

Rolling Mill Bearings

Engineering Section

Separately Sold Rail for NSK Linear Guide

LH series Standard Rail

- L1H : Clearance Interchangeable Type
- L1H-Z : Preloaded Interchangeable Type

LH series Butting Rail

- L1H-01 : Clearance Interchangeable Type
- L1H-01Z : Preloaded Interchangeable Type

LH series butting rail features higher precision tolerances for L_0 and G dimensions.

Linear Guides

LH Series
Rail Dimension Table

L1H 25 1200 - 01 C Z

Rail Type	No Code: Clearance Type Z: Preloaded Type
Size No.	Material Code No Code: Standard carbon steel S: Stainless Steel (standard for LU and LE series) D: Carbon steel + Raydent coating H: Stainless steel + Raydent coating A: Carbon Steel + Armoloy B: Stainless Steel + Armoloy F: Fluoride Black Chrome Plating
Rail Length (mm)	
No Code: Standard 01: Butting Rail	

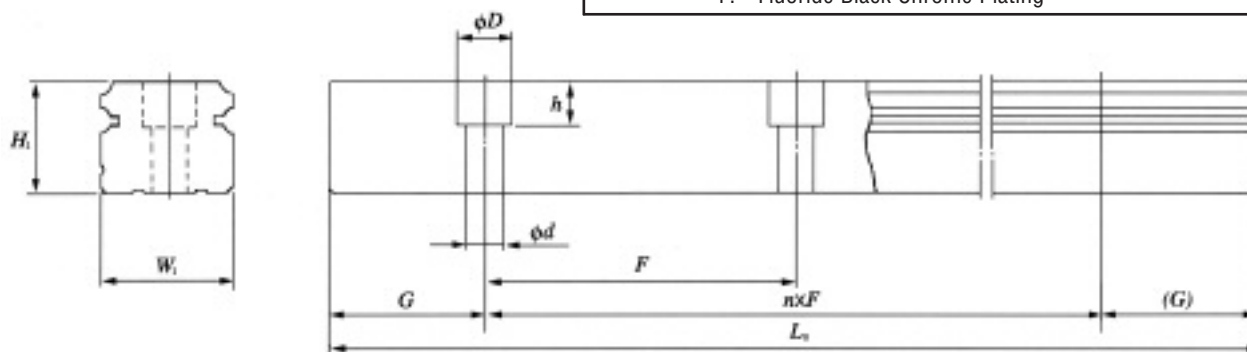

Rail Dimensions Table

Unit: mm

1 mm = 3.937×10^{-2} inch
1 kgf/m = $6,721 \times 10^{-1}$ Ft/Lb

Model No.		Max. rail length L_0 max. () indicates Stainless Steel	W_1	H_1	F	$d \times D \times h$	Rail Butting $G_{-0.5}^0$	Standard G	Rail Weight (kg/m)
Standard	Butting								
L1H15	L1H15-01	1440	15	15	60	4.5 x 7.5 x 5.3	30	20	1.6
L1H15-Z	L1H15-01Z	(1260)							
L1H20	L1H20-01	3960	20	18	60	6 x 9.5 x 8.5	30	20	2.6
L1H20-Z	L1H20-01Z	(3460)							
L1H25	L1H25-01	3960	23	22	60	7 x 11 x 9	30	20	3.6
L1H25-Z	L1H25-01Z	(3460)							
L1H30	L1H30-01	4000	28	26	80	9 x 14 x 12	40	20	5.2
L1H30-Z	L1H30-01Z	(3480)							
L1H35	L1H35-01	4000	34	29	80	9 x 14 x 12	40	20	7.2
L1H35-Z	L1H35-01Z								
L1H45	L1H45-01	3990	45	38	105	14 x 20 x 17	52.5	22.5	12.3
L1H45-Z	L1H45-01Z								
L1H55	L1H55-01	3960	53	44	120	16 x 23 x 20	60	30	16.9
L1H55-Z	L1H55-01Z								
L1H65	L1H65-01	3900	63	53	150	18 x 26 x 22	75	35	24.3
L1H65-Z	L1H65-01Z								

Cut to length rails $G = F/2$ (± 0.05 mm)

LH Series Accessories

Protector and Double Seal

Travel length is reduced by the thickness of the end seal on the ball slide. Consider the value of V_1 in the table below when calculating the travel length.

Protector Seal			Unit : mm
Linear Guide Model No.	Protector No. Plug End	Protector No. Grease Fitting End	Increased Thickness V1
LH15	LH15PT-01	LH15PTC-01	2.7
LH20	LH20PT-01	LH20PTC-01	2.9
LH25	LH25PT-01	LH25PTC-01	3.2
LH30	LH30PT-01	LH30PTC-01	4.2
LH35	LH35PT-01	LH35PTC-01	4.2
LH45	LH45PT-01	LH45PTC-01	4.9
LH55	LH55PT-01	LH55PTC-01	4.9
LH65	LH65PT-01	LH65PTC-01	5.5

One of each PT and PTC is required to do one linear bearing.

Double Seal			Unit : mm
Linear Guide Model No.	Double Seal No. Plug End	Double Seal No. Grease Fitting End	Increased Thickness V2
LH15	LH15WS-01	LH15WSC-01	2.5
LH20	LH20WS-01	LH20WSC-01	2.5
LH25	LH25WS-01	LH25WSC-01	2.8
LH30	LH30WS-01	LH30WSC-01	3.6
LH35	LH35WS-01	LH35WSC-01	3.6
LH45	LH45WS-01	LH45WSC-01	4.3
LH55	LH55WS-01	LH55WSC-01	4.3
LH65	LH65WS-01	LH65WSC-01	4.9

One of each WS and WSC is required to do one linear bearing.

Fig. 8 Protector and Double Seal

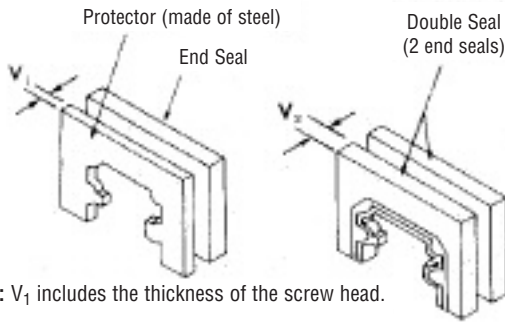

NOTE: V_1 includes the thickness of the screw head.

Adapters

These parts connect piping to the tapped hole when the grease fitting is removed.

Fig. 6 LF Type

For LH20, 25
LH30, 35

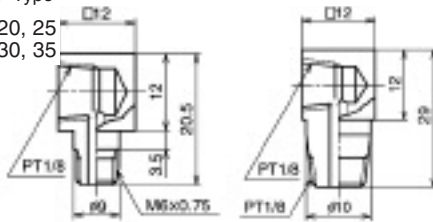

Reference No.:
L80206021-301

Reference No.:
L80200029-302

Fig. 7 SF Type

For LH20, 25
LH30, 35

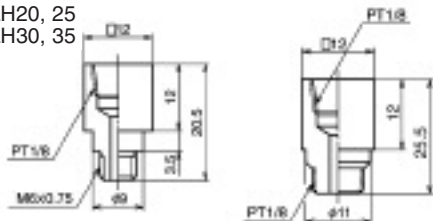

Reference No.:
L80106021-301

Reference No.:
L80100025-301

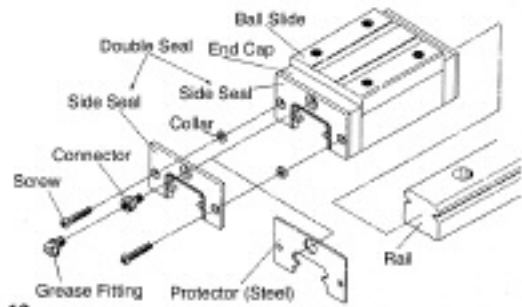

Fig. 13

*NOTE: - The protector (steel) is always ahead of the side or double seal.

Plastic Cap for Rail Mounting Hole

Linear Guide Model No.	Rail Mounting Bolt Size	Cap. No. for Rail Mounting Hole
LH15	M4	L45800004-003
LH20	M5	L45800005-003
LH25	M6	L45800006-003
LH30	M8	L45800008-003
LH35		
LH45	M12	L45800012-003
LH55	M14	L45800014-003
LH65	M16	L45800016-003

Brass Cap for Rail Mounting Hole

Linear Guide Model No.	Rail Mounting Bolt Size	Cap. No. for Rail Mounting Hole
LH20	M5	L45800005-004
LH25	M6	L45800006-004
LH30	M8	L45800008-004
LH35		
LH45	M12	L45800012-004

Identification Number

Linear Guides

Refer to the following numbering system when ordering.

LS Series

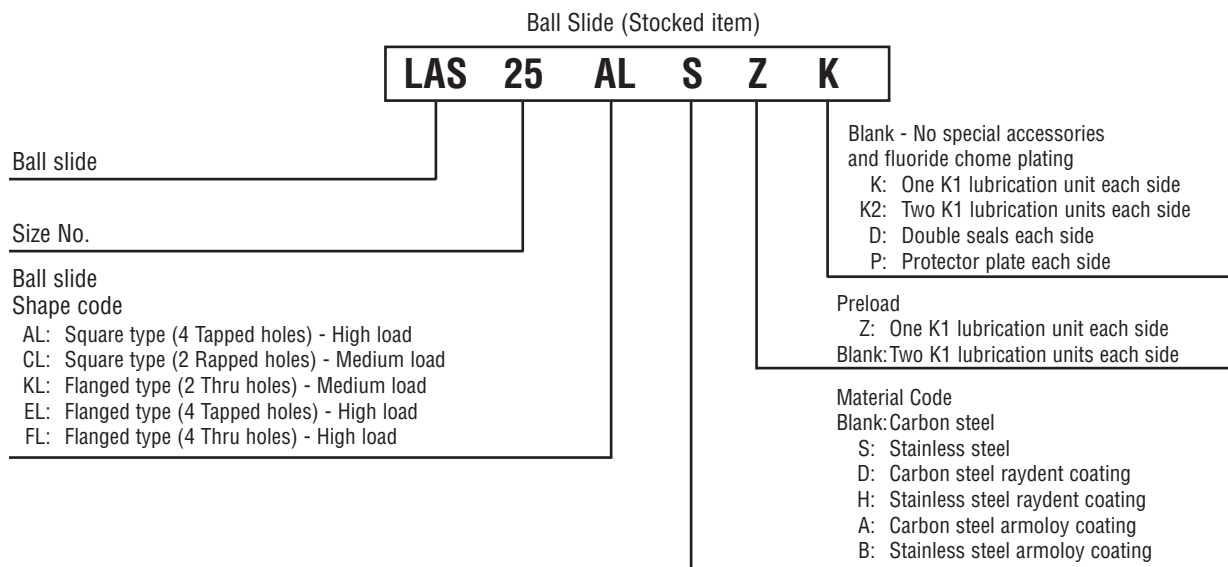

- Flanged Type
 - LS-EL (High Load) with 4 Tapped Holes
 - LS-FL (High Load) with 4 Thru Holes
 - LS-KL (Medium Load) with 2 Thru Holes
 - Square Type
 - LS-AL (High Load) with 4 Tapped Holes
 - LS-CL (Medium Load) with 2 Tapped Holes
- Both types have stainless steel series.

Fig.-1 LS-AL, LS-CL

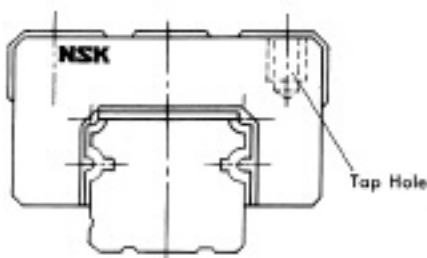
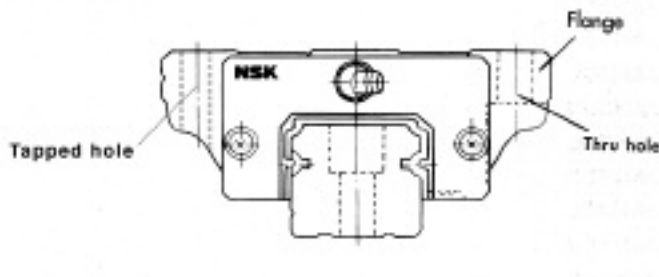

Fig.-2 LS-EL, LS-FL, LS-KL



Radial Clearance and Preload

The clearance when interchangeable rail and ball slide components are combined is as listed in Table 2. Minus symbol indicates the preload.

Table 2 Clearance of Interchangeable Linear Guide Unit: μm

Model No.	Clearance	Light Preload Z
LS15	15~-4	0~-4
LS20	15~-4	0~-4
LS25	15~-5	0~-5
LS30	15~-5	0~-5
LS35	15~-5	0~-6

*Consult NSK for price and delivery.

Accuracy Standard

The accuracy standard of the NSK “Compact Low Profile LS-Series” is shown in Table 1. With high-accuracy control of individual rail size and interchangeability, the accuracy of Table 1 can be maintained sufficiently even after addition or replacement of the ball slide.

Table 1 Tolerances Unit : μm

Tolerances (See Fig. 4 for Symbols)		Model No. LS
		15, 20, 25, 30, 35
Clearance Type	Overall Height, H	± 20
	Lateral Width, W_2	± 30
Preload Type	Overall Height, H	± 20
	Lateral Width, W_2	± 30
Running Parallelism of Face [C] to Face [A]		Refer to Fig. 3
Running Parallelism of Face [D] to Face [B]		

W_2 is applicable to the reference side only. Note: during installation the reference side is indicated by a line provided on the side of ball slide and rail. (See Fig. 4)

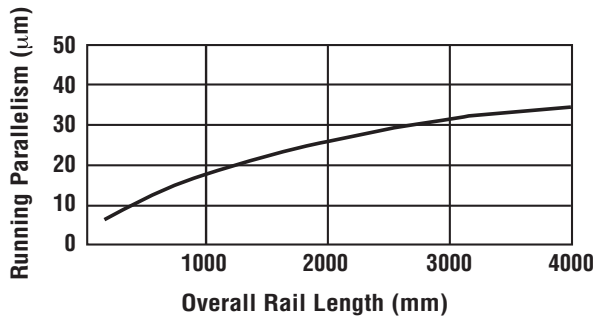

Fig. 3 Running Parallelism

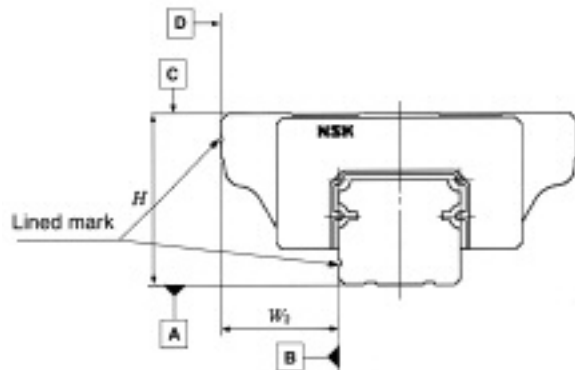

Fig. 4 Accuracy Standard

Load Rating and Life

The LS-Series is based on a design applying load from above. Therefore the dimension table shows the basic dynamic load rating C and basic static load rating C_0 for the downward direction. If the load is applied laterally or upward refer to values in Table 2.

Table 2 Basic Load Rating Correction for Direction

Load Direction	Basic Dynamic Load Rating	Basic Static Load Rating
Downward	C	C_0
Upward	C	$0.75C_0$
Laterally	$0.88C$	$0.63C_0$

Estimate the life of linear guides using the equation below.

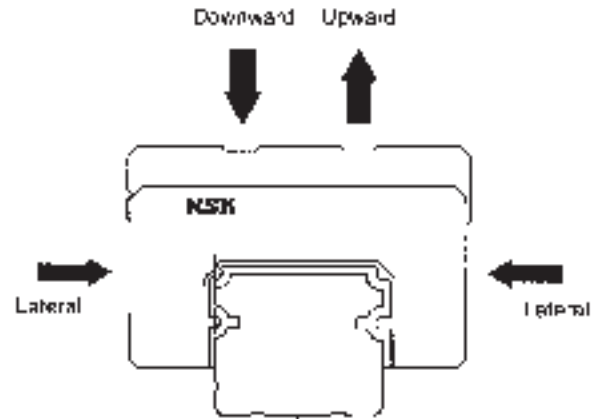

Fig. 5

$$L = 50 \left(\frac{C}{f_W \cdot F} \right)^3$$

where, L : Rated fatigue life(km)

C : Basic dynamic load rating (kgf)

F : Load to a ball slide (kgf)
(Dynamic equivalent load)

f_W : Load factor

$f_W = 1.0 \sim 1.2$ (Smooth condition)

$f_W = 1.2 \sim 1.5$ (Normal condition)

$f_W = 1.5 \sim 3.0$ (With shock or vibration)

Square Type	
LAS-CL (Z) :	Standard Steel
LAS-AL (Z) :	
LAS-CLS (Z) :	Stainless Steel
LAS-ALS (Z) :	

Note: Consult NSK for price and delivery on stainless steel.

Linear Guides

LS Series
Ball Slide Dimension Table

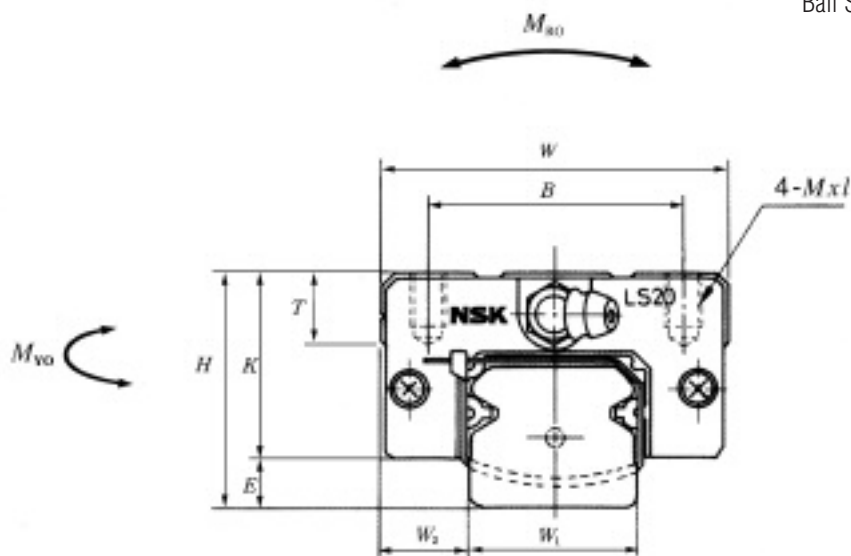

Model No.	Ass'y Dimensions			Ball Slide Dimensions								
	H	E	W ₂	W	B	L	L ₁	J	J ₁	K	T	M x l
LAS15 CL/CLZ LAS15 AL/ALZ	24	4.6	9.5	34	26	40.4 56.8	23.6 40	— 26	11.8 7	19.4	10	M 4 x 6
LAS20 CL/CLZ LAS20 AL/ALZ	28	6	11	42	32	47.2 65.2	30 48	— 32	15 8	22	12	M 5 x 7
LAS25 CL/CLZ LAS25 AL/ALZ	33	7	12.5	48	35	59.6 81.6	38 60	— 35	19 12.5	26	12	M 6 x 9
LAS30 CL/CLZ LAS30 AL/ALZ	42	9	16	60	40	67.4 96.4	42 71	— 40	21 15.5	33	13	M 8 x 12
LAS35 CL/CLZ LAS35 AL/ALZ	48	10.5	18	70	50	77 108	49 80	— 50	24.5 15	37.5	14	M 8 x 12

Note: W₁ rail dimensions are on Page 250.

Introduction

Ball Bearings

Cylindrical Roller Bearings

Spherical Roller Bearings

Tapered Roller Bearings

Thrust Bearings

Split Pillow Blocks

Super Precision Bearings

Linear Motion

Rolling Mill Bearings

Engineering Section

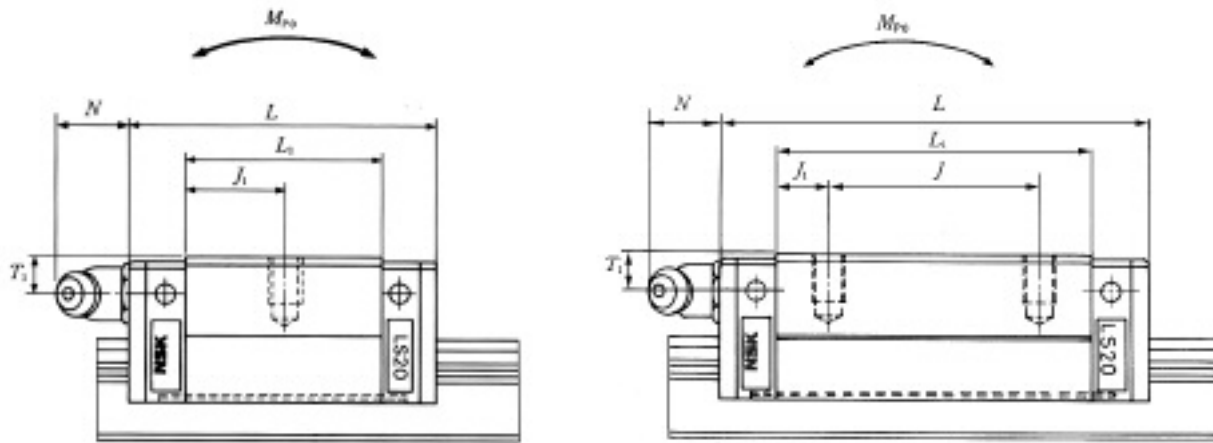

Unit : mm

Grease Fitting			Basic Load Ratings					Weight (kgf)	Model No.
Mounting Hole Thread Spec.	T_1	N	Dynamic C (kgf)	Static C_0 (kgf)	Static Moment (kgf•m)				
					M_{RO}	M_{PO}	M_{YO}		
Ø3 (Thru Hole)	6	3	550	930	4	2	2	0.14	LAS15 CL/CLZ LAS15 AL/ALZ
			850	1720	7	5	5	0.20	
M6x0.75	5.5	11	810	1370	9	4	4	0.19	LAS20 CL/CLZ LAS20 AL/ALZ
			1190	2400	13	9	9	0.28	
M6x0.75	7	11	1300	2120	14	7	7	0.34	LAS25 CL/CLZ LAS25 AL/ALZ
			1920	3720	25	21	20	0.51	
M6x0.75	8	11	1910	3020	25	11	11	0.58	LAS30 CL/CLZ LAS30 AL/ALZ
			2940	5610	48	36	36	0.85	
M6x0.75	8.5	11	2650	4080	42	18	18	0.86	LAS35 CL/CLZ LAS35 AL/ALZ
			4080	7600	79	58	57	1.25	

Introduction

Ball Bearings

Cylindrical Roller Bearings

Spherical Roller Bearings

Tapered Roller Bearings

Thrust Bearings

Split Pillow Blocks

Super Precision Bearings

Linear Motion

Rolling Mill Bearings

Engineering Section

Flange Type	
LAS-KL (Z) :	Standard Steel
LAS-FL (Z) :	
LAS-EL (Z) :	
LAS-KLS (Z) :	Stainless Steel
LAS-KLS (Z) :	

Note: Consult NSK for price and delivery on stainless steel.

Linear Guides

LS Series

Ball Slide Dimension Table

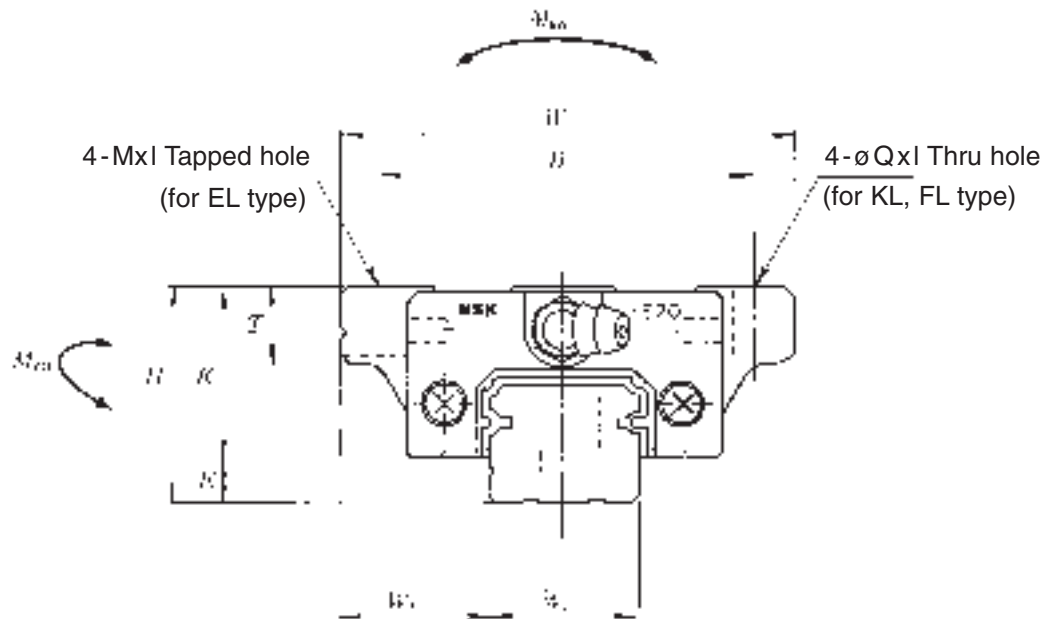

Model No.	Ass'y Dimensions				Ball Slide Dimensions								
	H	E	W ₂	W	B x J	L	L ₁	J ₁	K	T	Q x I	M x I	Bolt Size Thru Hole Q
LAS15 KL/KLZ	24	4.6	18.5	52	41 x 26	40.4	23.6	11.8	19.4	8	4.5 x 7	M 5 x 8	M4
LAS15 FL/FLZ					41 x 26	56.8	40.0	7.0			4.5 x 7		M4
LAS15 EL/ELZ					41 x 26	56.8	40.0	7.0					
LAS20 KL/KLZ	28	6.0	19.5	59	49 x 32	47.2	30.0	15.0	22.0	10	5.5 x 9	M 6 x 10	M5
LAS20 FL/FLZ					49 x 32	65.2	48.0	8.0			5.5 x 9		M5
LAS20 EL/ELZ					49 x 32	65.2	48.0	8.0					
LAS25 KL/KLZ	33	7.0	25.5	73	60 x 35	59.6	38.0	19.5	26.0	11	7 x 10	M 8 x 12	M6
LAS25 FL/FLZ					60 x 35	81.6	60.0	12.5			7 x 10		M6
LAS25 EL/ELZ					60 x 35	81.6	60.0	12.5					
LAS30 KL/KLZ	42	9.5	31.0	90	72 x 40	67.4	42.0	21.5	33.5	11	9 x 12	M 10 x 18	M8
LAS30 FL/FLZ					72 x 40	96.4	71.0	15.5			9 x 12		M8
LAS30 EL/ELZ					72 x 40	96.4	71.0	15.5					
LAS35 KL/KLZ	48	10.5	33.0	100	80 x 50	77.4	49.0	24.5	37.5	12	9 x 13	M 10 x 20	M8
LAS35 FL/FLZ					82 x 50	108.0	80.0	15.0			9 x 13		M8
LAS35 EL/ELZ					82 x 50	108.0	80.0	15.0					

*Note: W1 rail dimensions are on Page 250.

Introduction

Ball Bearings

Cylindrical Roller Bearings

Spherical Roller Bearings

Tapered Roller Bearings

Thrust Bearings

Split Pillow Blocks

Super Precision Bearings

Linear Motion

Rolling Mill Bearings

Engineering Section

Linear Guides

LS Series

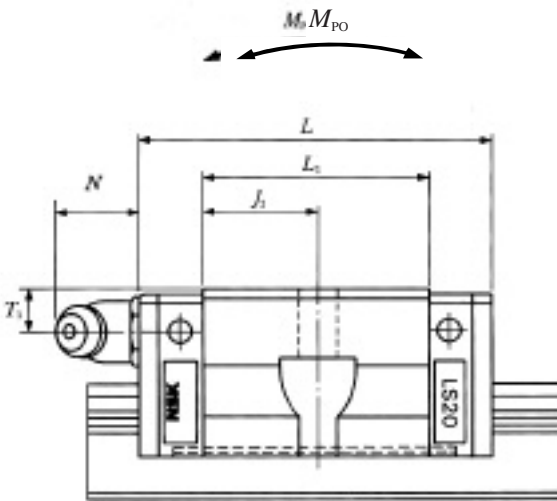

LAS-KL/KLZ

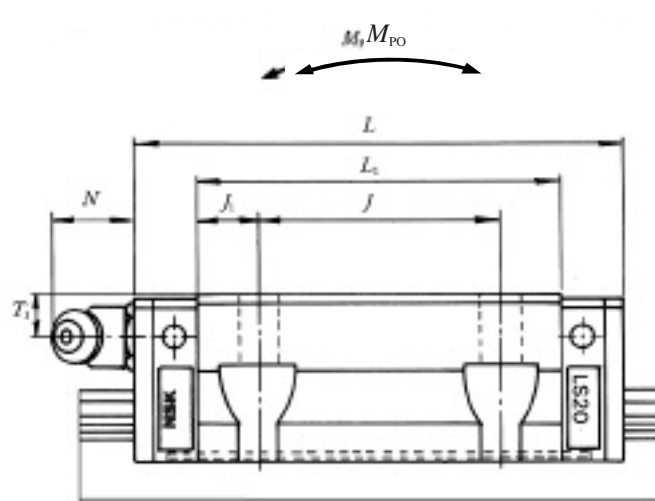

**LAS-FL/FLZ
LAS-EL/ELZ**

Grease Fitting			Basic Load Ratings					Weight (kgf)	Model No.
Mounting Hole Thread Spec.	T ₁	N	Dynamic C (kgf)	Static C ₀ (kgf)	Static Moment (kgf·m)				
					M _{RO}	M _{PO}	M _{VO}		
Ø3 (Thru Hole)	6.0	3	550	930	4	2	2	0.17	LAS15 KL/KLZ
			850	1720	7	5	5	0.26	LAS15 FL/FLZ
			850	1720	7	5	5	0.26	LAS15 EL/ELZ
M6x0.75	5.5	11	810	1370	9	4	4	0.24	LAS20 KL/KLZ
			1190	2400	13	9	9	0.35	LAS20 FL/FLZ
			1190	2400	13	9	9	0.35	LAS20 EL/ELZ
M6x0.75	7.0	11	1300	2120	14	7	7	0.44	LAS25 FL/FLZ
			1920	3720	25	21	20	0.66	LAS25 EL/ELZ
			1920	3720	25	21	20	0.66	LAS30 KL/KLZ
M6x0.75	8.0	11	1910	3020	25	11	11	0.76	LAS30 FL/FLZ
			2940	5610	48	36	36	1.2	LAS30 EL/ELZ
			2940	5610	48	36	36	1.2	LAS30 EL/ELZ
M6x0.75	8.5	11	2650	4080	42	18	18	1.2	LAS35 KL/KLZ
			4080	7600	79	58	57	1.7	LAS35 FL/FLZ
			4080	7600	79	58	57	1.7	LAS35 EL/ELZ

Unit : mm

LS series Standard Rail

LS : Clearance Interchangeable Type
L1S : Preloaded Interchangeable Type

Linear Guides

LS Series

Rail Dimension Table

Separately Sold Rail for NSK Linear Guide

Identification Number Rail

L1S 25 3960 -01 T S Z

Type Slide

Size No.

Rail Length (mm)

No code: Standard
-01: Butted rail

For L1S15 Rail Size Only:

No code: Counterbore hole in rail for M3
T: Counterbore hole in rail for M4

Preload Code

Z: Light preload
Blank: Clearance type

Material Code

Blank: Carbon steel
S: Stainless steel
D: Carbon steel raydent coating
H: Stainless steel raydent coating
A: Carbon steel armoloy coating
B: Stainless steel armoloy coating

Model No.	Rail Dimensions							
	Weight W ₁	H1	Pitch F	Bolt Hole d x D x H	Rail Butting G	Max. rail length Standard G Stainless Steel	L0 max. () indicates (kgf/m)	Weight Rail
L1S15	15	12.5	60	3.5 x 6 x 4.5	30	20	1500 (1000)	1.4
L1S15T	15	12.5	60	4.5 x 7.5 x 5.3	30	20	1500 (1000)	1.4
L1S20	20	15.5	60	6 x 9.5 x 8.5	30	20	3960 (3500)	2.3
L1S25	23	18.5	60	7 x 11 x 9	30	20	3960 (3500)	3.1
L1S30	28	23.5	80	7 x 11 x 9	40	20	4000 (3500)	4.8
L1S35	34	27.5	80	9 x 14 x 12	40	20	4000 (3500)	7.0

LS Series Accessories Protector and Double Seal

Travel length is reduced by the thickness of the end seal on the ball slide. Consider the value of V in the table below when calculating the travel length.

Linear Guide Model No.	Protector No. Plug End	Protector No. Grease Fitting End	Increased Thickness V1
LS15	LS15PT-01	LS15PTC-01	3.0.0
LS20	LS20PT-01	LS20PTC-01	2.7
LS25	LS25PT-01	LS25PTC-01	3.2
LS30	LS30PT-01	LS30PTC-01	4.2
LS35	LS35PT-01	LS35PTC-01	4.2

One of each PT and PTC is required to do one linear bearing.

Linear Guides

LS Series Accessories

Linear Guide Model No.	Double Seal No. Plug End	Double Seal No. Grease Fitting End	Increased Thickness V2
LS15	LS15WS-01	LS15WSC-01	2.8
LS20	LS20WS-01	LS20WSC-01	2.5
LS25	LS25WS-01	LS25WSC-01	2.8
LS30	LS30WS-01	LS30WSC-01	3.6
LS35	LS35WS-01	LS35WSC-01	3.6

One of each WS and WSC is required to do one linear bearing.

Fig. 7 Protector and Double Seal

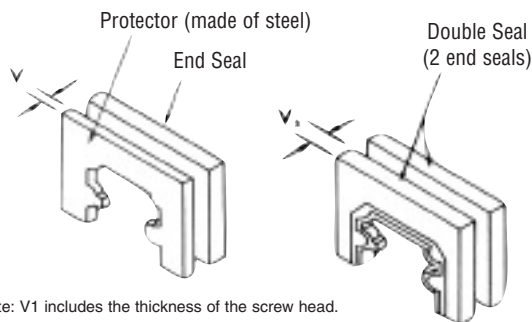

Note: V1 includes the thickness of the screw head.

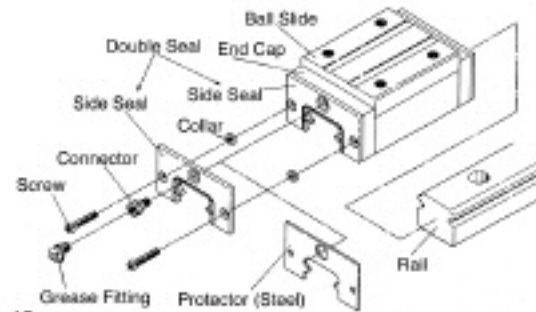

Fig. 13

*Note: - The protector (steel) is always ahead of the side or double seal.

Adapter

These parts connect piping to the tapped hole when the grease fitting is removed.

Fig. 5 LF Type

Adapter No. L80206021-301

For LS20, 25
For LS30, 35

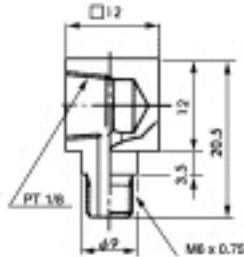

Fig. 6 SF Type

Adapter No. L80106021-301

For LS20, 25
For LS30, 35

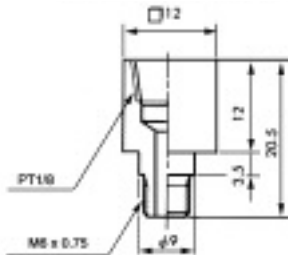

Table 12 Cap for Rail Mounting Hole

Linear Guide Model No.	Rail Mounting Bolt Size	Cap. No. for Rail Mounting Hole
LS15	M3	L45800003-003
LS20	M5	L45800005-003
LS25	M6	L45800006-003
LS30		L45800006-003
LS35	M8	L45800008-003

Brass Cap for Rail Mounting Hole

Linear Guide Model No.	Rail Mounting Bolt Size	Cap. No. for Rail Mounting Hole
LS20	M5	L45800005-004
LS25	M6	L45800006-004
LS30		L45800006-004
LS35	M8	L45800008-004

LU Series

Identification Number

Refer to the following numbering system when ordering.

Ball Slide (Stocked item)

LAU 12 AR S

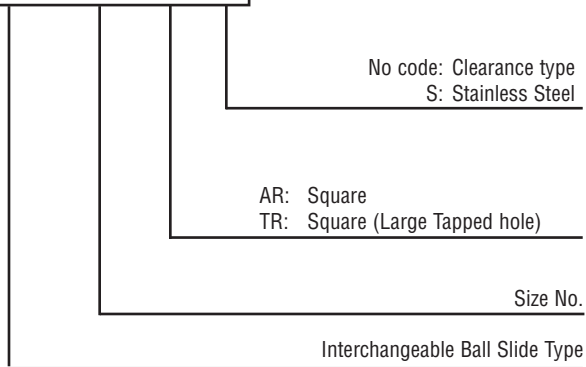

Rail (Stocked item)

L1U 12 0120 T S

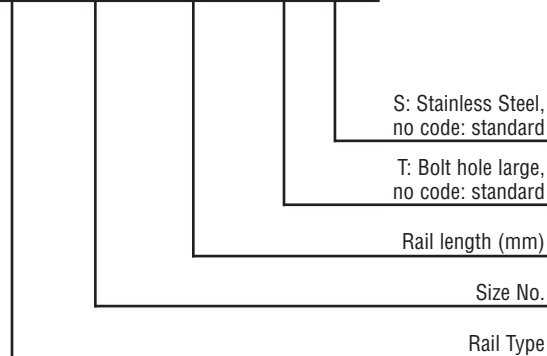

Ball Slide

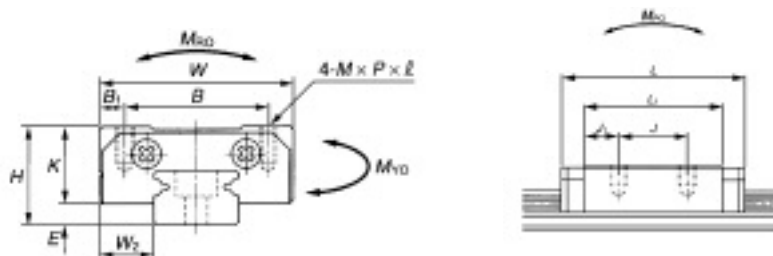

LU series ball slide dimension

Unit: mm

Model No.	Ass'y Dimension			Ball Slide Dimensions									Basic Load Rating			Weight (gf)		
	Height H	E	Width W ₂	Length W	L	B	Tapped Hole			L ₁	J ₁	K	Dynamic C (kgf)	Static C ₀ (kgf)	Static Moment (kgf•m)			
							J	M x P x l	B ₁						M _{RO}		M _{PO}	M _{YO}
LAU09ARS LAU09TRS	10	2.2	5.5	20	30	15	13 10	M2 x 0.4 x 2.5 M3 x 0.5 x 3	2.5	20	3.5 5.5	7.8	150	220	0.9	0.5	0.5	19
LAU12ARS LAU12TRS	13	3	7.5	27	35.2	20	15	M2.5 x 0.45 x 3 M3 x 0.5 x 3.5	3.5	21.8	3.4	10	290	360	2.2	1.2	38	38
LAU15ALS	16	4	8.5	32	43.6	25	20	M3 x 0.5 x 4	3.5	27	3.5	12	570	670	4.3	2.2	2.2	70

Rail

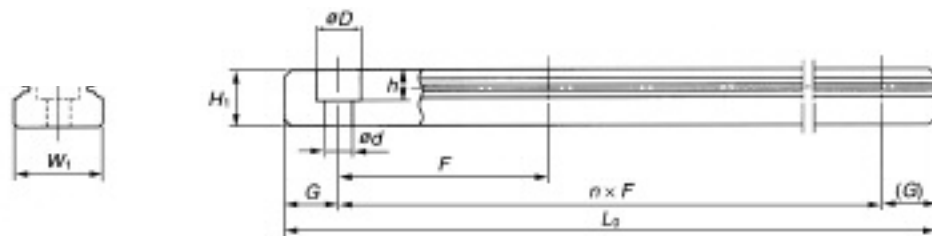

LU series rail dimension

Unit: mm

Model No	Standard Length (in stock)			Rail Dimension						Weight (gf/100mm)	
				Width W ₁	Length H ₁	Bolt pitch F	Bolt hole d x D x h	G (Standard)	Rail length L ₁ max		
L1U09*S L1U09*TS	115	195	275	9	5.5	20	2.6 x 4.5 x 3 3.5 x 6 x 4.5	7.5	275	35	
L1U12*S L1U12*TS	170	270	470	800	12	7.5	25	3 x 5.5 x 3.5 3.5 x 6 x 4.5	10	800	65
L1U15*S	230	430	670	990	15	9.5	40	3.5 x 6 x 4.5	15	1000 (Stainless: 670)	105

*Stainless Steel

LE Series

Identification Number

Refer to the following numbering system when ordering.

Ball Slide (Stocked item)

LAE 12 AR S

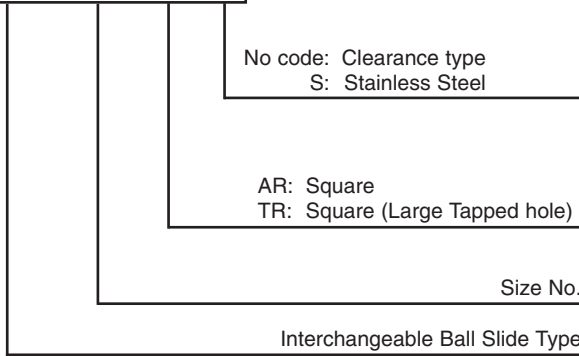

Rail (Stocked item)

L1E 12 0120 S

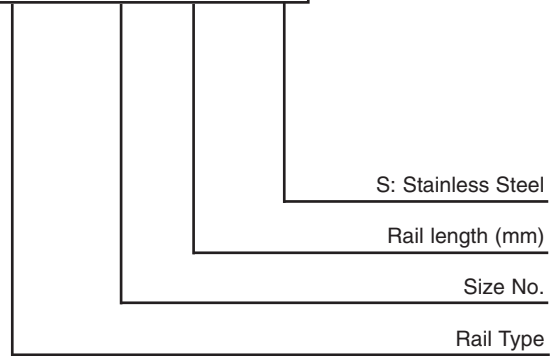

Ball Slide

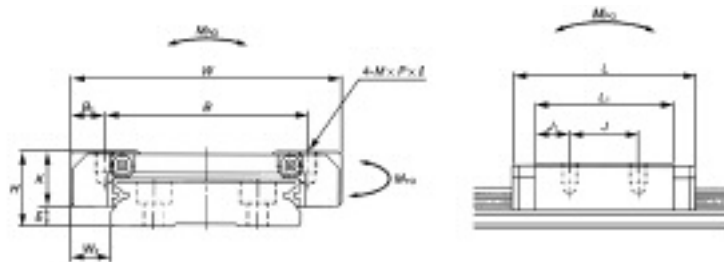

LE series ball slide dimension

Unit: mm

Model No.	Ass'y Dimension				Ball Slide Dimensions								Basic Load Rating					Weight (gf)
	Height H	E	W ₂	Width W	Length L	B	Tapped Hole			L ₁	J ₁	K	Dynamic C (kgf)	Static C ₀ (kgf)	Static Moment (kgf·m)			
							J	Thread M x P x l	B ₁						M _{Ro}	M _{Po}	M _{Vo}	
LAE09ARS								M2.6 x 0.45 x 3										
LAE09TRS	12	4	6	30	39.8	21	12	M3 x 0.5 x 3	4.5	27.6	7.8	8	310	460	3.3	1.7	1.7	40
LAE12ARS	14	4	8	40	45	28	15	M3 x 0.5 x 4	6.0	31	8	10	440	650	6.0	2.4	2.4	75
LAE15ARS	16	4	9	60	56.6	45	20	M4 x 0.7 x 4.5	7.5	38.4	9.2	12	780	1060	17.7	4.9	4.9	150

Rail

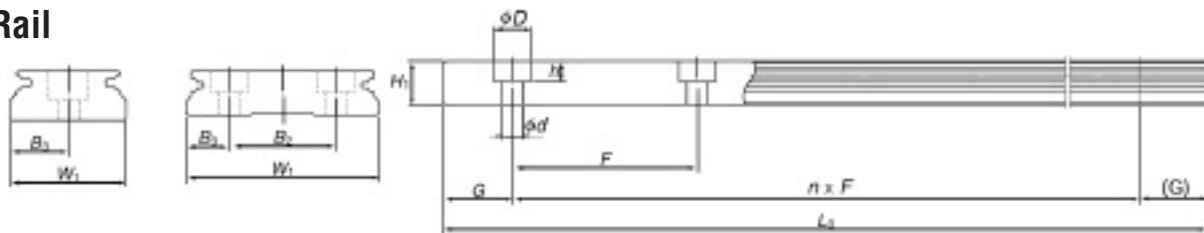

LE series rail dimension

Unit: mm

Model No.	Standard Length (in stock)			Rail Dimension									Weight (gf/100mm)
				Width W ₁	Length H ₁	Bolt pitch F	B ₂	B ₃	Bolt hole d x D x h	G hole (Standard)	Rail length L ₀ max		
L1E09*S	110	200	290	380	18	7.5	30	-	9.5	3.5 x 6 x 4.5	10	400	95
L1E12*S	150	310	470	790	24	8.5	40	-	12.5	4.5 x 8 x 4.5	15	800	140
L1E15*S	230	430	670	990	42	9.5	40	23	9.5	4.5 x 8 x 4.5	15	1000	275

*Stainless Steel

LW Series

Identification Number

Refer to the following numbering system when ordering.

Ball Slide (Stocked item)

LAW 27 EL Z

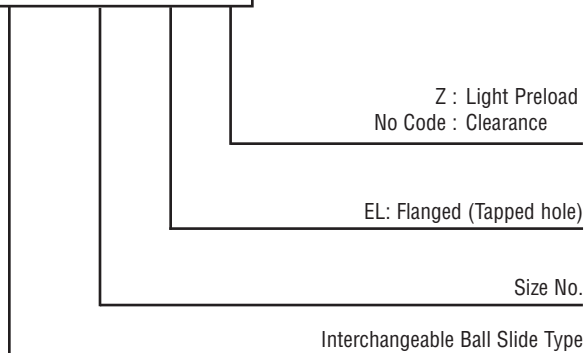

Rail (Stocked item)

L1W 27 0820 Z

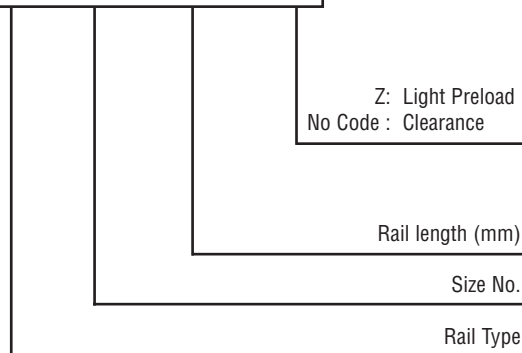

Ball Slide

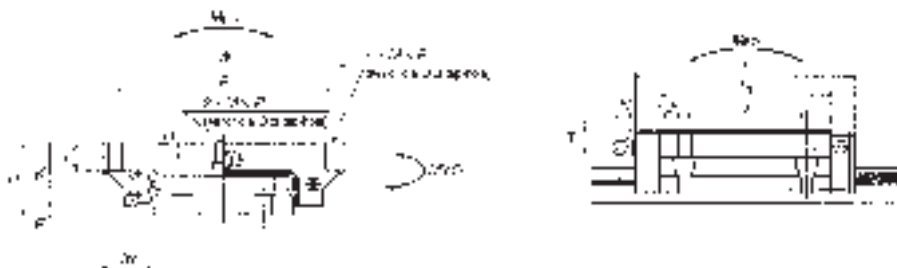

LW series ball slide dimension

Unit: mm

Model No.	Assembly Dimension					Ball Slide Dimensions										Basic Load Rating						Weight (kgf)
	Height H	E	W ₂	Width W	Length L	Tapped Hole				L ₁	J ₁	K	T	Grease fitting			Dynamic C(kgf)	Static C ₀ (kgf)	Static Moment (kgf·m)			
						B x J	Thread M x P	T ₁	Q					T ₁	T ₁	N			M _{RO}	M _{PO}	M _{VO}	
LAW17EL/ELZ	17	2.5	13.5	60	51.4	53 x 26	M4 x 0.7	3.2	3.3	35	4.5	14.5	6	ø3 thru hole	4	3	570	1150	11.6	3.7	3.4	0.2
LAW21EL/ELZ	21	3	15.5	68	58.8	60 x 29	M5 x 0.8	3.7	4.4	41	6	18	8	M6 x 0.75	4.5	11	660	1420	15.0	4.8	4.5	0.3
LAW27EL/ELZ	27	4	19	80	74	70 x 40	M6 x 1	6	5.3	56	8	23	10	M6 x 0.75	6	11	1310	2740	35.6	14.3	13.8	0.5
LAW35EL/ELZ	35	4	25.5	120	108	107 x 60	M8 x 1.25	8	6.8	84	12	31	14	M6 x 0.75	8	11	3370	6780	149.5	54.4	53.3	1.5
LAW50EL/ELZ	50	4.5	36	162	140.6	144 x 80	M10 x 1.5	14	8.6	108	14	45.5	18	PT 1/8	14	14	6270	11930	347.0	128.9	126.2	4.0

Rail

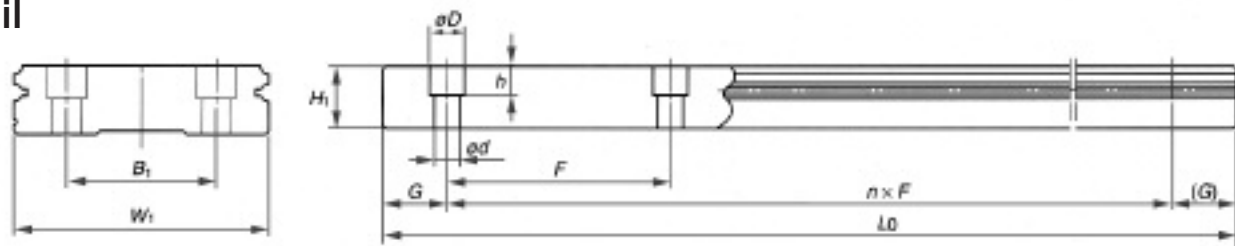

LW series rail dimension

Unit: mm

Model No.	Standard Length (in stock)					Rail Dimension					Rail length L ₀ max	Weight (kgf/m)	
						Width W ₁	Height H ₁	Bolt pitch F	B ₁	Bolt hole d x D x h			G (Standard)
L1W17	430	670	990			33	8.7	40	18	4.5 x 7.5 x 5.3	15	1000	2.1
L1W21	430	680	980			37	10.5	50	22	4.5 x 7.5 x 5.3	15	1600	2.9
L1W27	460	640	820	1000		42	15	60	24	4.5 x 7.5 x 5.3	20	2000	4.7
L1W35	440	600	760	1000	1240	69	19	80	40	7 x 11 x 9	20	2400	9.6
L1W50	440	600	760	1000	1240	90	24	80	60	9 x 14 x 12	20	3000	15.8

Assembly

Interchangeable ball slides are shipped on (disposable) plastic provisional rails as shown in Fig.-9.

1. Wipe off anticorrosive oil from the rail.
2. Since Alvania (AV2) grease is packed in the ball slide, you can use it as delivered.
3. Align the rail with bottom and side faces of provisional rail and while pushing the provisional rail lightly against the rail, slide the ball slide on to the rail (Fig.-9).

Fig. 9 Assembly of Ball Slide with Rail

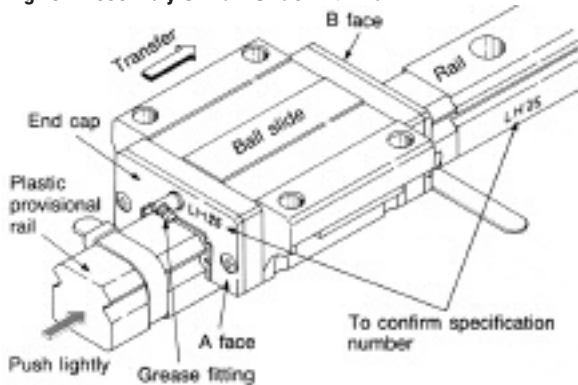

Mounting Method

Shoulder Height and Corner Shape at Mounting Face

When utilizing the reference surface to secure rail or ball slides to machine components the components must have the mounting face height (H' , H'') and corner chamfer (r) dimensions as listed in Table 6 and illustrated in Figs. 10 and 11, to avoid interference.

Table 6 Shoulder height and corner shape at mounting face (LH, LS Series) Unit : mm

Product No.	Radius of corner r (max.)	Shoulder Height of Rail H'	Shoulder Height of Ball Slide H''
15	0.5	4.0	4.5
20	0.5	4.5	5.0
25	0.5	5.0	5.0
30	0.5	6.0	6.0
35	0.5	6.0	6.0
45	0.7	8.	8.0
55	0.7	10.0	10.0
65	1.0	11.0	11.0

Fig. 10 Rail Datum Face Mounting Part

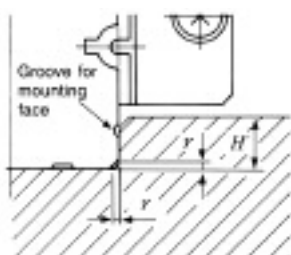
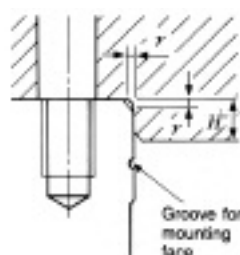

Fig. 11 Ball Slide Datum Face Mounting Part



Mounting Procedure

For cases where datum surface exists on the bed

1. Lightly tighten the rail mounting bolts and then use the shoulder plate to secure rail datum surface against bed mounting surface (See Fig. 12).
2. Tighten rail mounting bolts to their recommended torques (Table 7). Tighten the bolts in an order which enables the wrench to help push the rail against the mounting surface (see Fig. 13 for example).

Fig. 12 Positioning of Rail Table

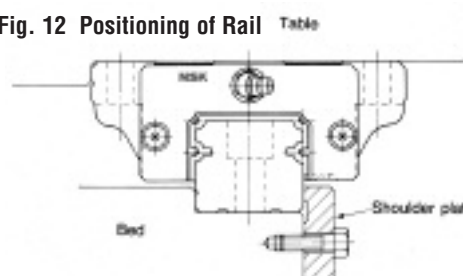
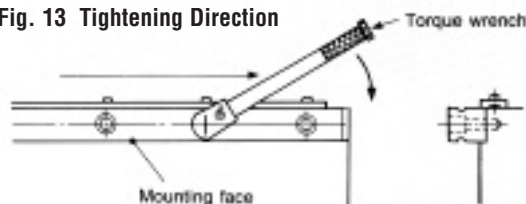

Table 7 Recommended Torque for Rail Mounting Bolt (case of thermally refined bolt) Unit : kgf·cm

Bolt Nominal No.	Torque	Bolt Nominal No.	Torque
M3	10.8	M10	440
M4	25.0	M12	770
M5	52.0	M14	1240
M6	88.0	M16	2000
M8	220.0		[1 kg·cm=0.8681 Lb in]

Fig. 13 Tightening Direction



3. Mount the adjust side rail, as shown in Fig.-14, while checking rail parallelism. For the jig shown in Fig.-14, stability will be improved by mounting it on 2 ball slide.

Fig. 14 Parallelism Measurement with Jigs

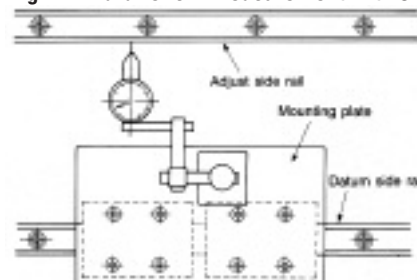

4. If dowel pins are being used they should be installed at this step.
5. Position the ball slides at specified intervals and mount the table gently.
6. Tighten ball slide mounting bolts of datum side while pushing the table so that the table and ball slide mounting reference surfaces are in contact.

Introduction
 Ball Bearings
 Cylindrical Roller Bearings
 Spherical Roller Bearings
 Tapered Roller Bearings
 Thrust Bearings
 Split Pillow Blocks
 Super Precision Bearings
 Linear Motion
 Rolling Mill Bearings
 Engineering Section

Indication of Installed Standard Side

The datum face of each rail is indicated by a groove in the datum face or by an arrow mark on the end or top surface of the rail.

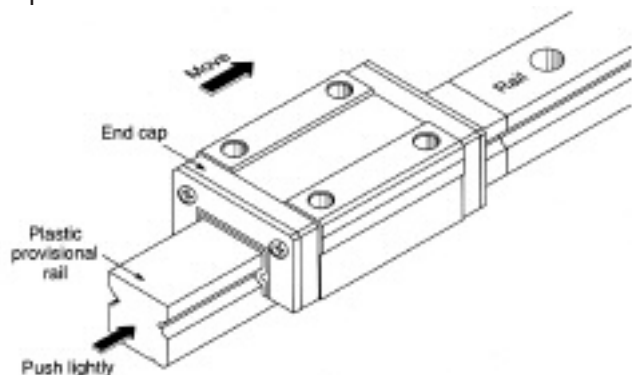

Lubrication

Grease Lubrication

NSK linear guides are packed with Alvania 2 grease and can be used as delivered. The replenishment frequency is recommended to be once a year, but adjust the interval depending on the operation conditions.

(1) To Change Direction of Grease Fitting

1. Remove the grease fitting with a wrench.
2. Wind some sealing tape on the thread of the fitting, then insert it and tighten. Be careful not to over torque when tightening into the side of the plastic bearing end cap.

(2) Change of Fitting Position in Front/Back Direction

1. Remove the plug from the grease fitting mounting hole face B shown in Fig.-9 with a hexagonal wrench.
2. Remove the grease fitting from face A and screw into hole face B.
3. In place of the removed fitting, insert the plug into the hole in the face A.

(3) Change Grease Fitting Position to Side Surface

To mount the grease fitting on the end cap side face, or on the ball slide face, please consult NSK.

Oil Lubrication

Oil piping can be connected to the tapped hole from where the grease fitting was removed. Piping joints are listed on page 13 and page 21. The recommended lubrication oil supply quantity per ball slide per hour Q is given by the following formula, where N is the rail width number.

$$Q = \frac{N \text{ (ml/hr)}}{150} \dots \dots \dots (5)$$

Using LH45 as an example, N=45, and

$$Q = \frac{45}{150} = 0.3 \text{ (ml/hr)}$$



Notes on Usage

Separately packaged ball slide is mounted on a plastic temporary axis (disposable) as shown at left.

1. Wipe anti-rust oil from the rail.
2. Product is ready for use as is since Alvania 2 grease is sealed inside the ball slide.
3. Note the groove mark which identifies the datum faces of ball slide and rail above.
4. Move the ball slide, matching and slightly pushing the base and the side of provisional rail to the rail as in drawing at left.

Grease Fittings for NSK Ball Slides

Type	Linear Guide Model #	Grease Fitting Part #	Thread Spec.
Drive	LH15, LS15, LW17	L50010000-301	Dia. 3mm
A	lh, ls 20, 25, 30, 35	L50000000-001	M6X0.75MM
B	Same	L50100000-001	M6X0.75MM
C	Same plus LW21, 27, 35	L50200000-001	M6X0.75MM
A	lh 45, 55, 65	L50003000-001	PT 1/8
B	Same	L50103000-001	PT 1/8
C	Same plus LW50	L50203000-001	PT 1/8

Fig. 15 Shape of Grease Fitting

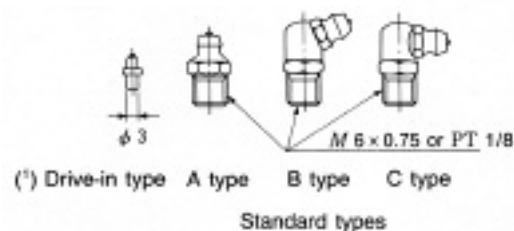

- (1) Applies only to model No. LH15, LS15 and LW17.

NSK Grease Unit

Replenish grease to NSK linear guides and ball screws by a manual type hand grease pump. Install the grease in bellows tube to the pump. Several types of grease (80 g) are available.



Grease in a bellows tube



(1) Composition of NSK Grease Unit

Components and grease types are shown below.

NSK Grease Unit		Name	(tube type)	Reference number
NSK Grease (80 g in a bellows tube)	NSK Grease AV2	NSK Grease AV2	(Brown)	NSK GRS AV2
	NSK Grease PS2	NSK Grease PS2	(Orange)	NSK GRS PS2
	NSK Grease LR3	NSK Grease LR3	(Green)	NSK GRS LR3
	NSK Grease LG2	NSK Grease LG2	(Blue)	NSK GRS LG2
NSK Hand Grease Pump Unit	NSK Hand Grease Pump (Straight nozzle NSK HGP NZ1 -- One nozzle is provided with the hand pump.)			NSK HGP
	Grease nozzle (used with the hand grease pump)	NSK straight nozzle		NSK HGP NZ1
		NSK chuck nozzle		NSK HGP NZ2
		NSK drive fitting nozzle		NSK HGP NZ3
		NSK point nozzle		NSK HGP NZ4
		NSK flexible nozzle		NSK HGP NZ5
		NSK flexible extension pipe		NSK HGP NZ6
		NSK straight extension pipe		NSK HGP NZ7

(2) NSK Greases (80 g in a bellows tube) Bellows tube

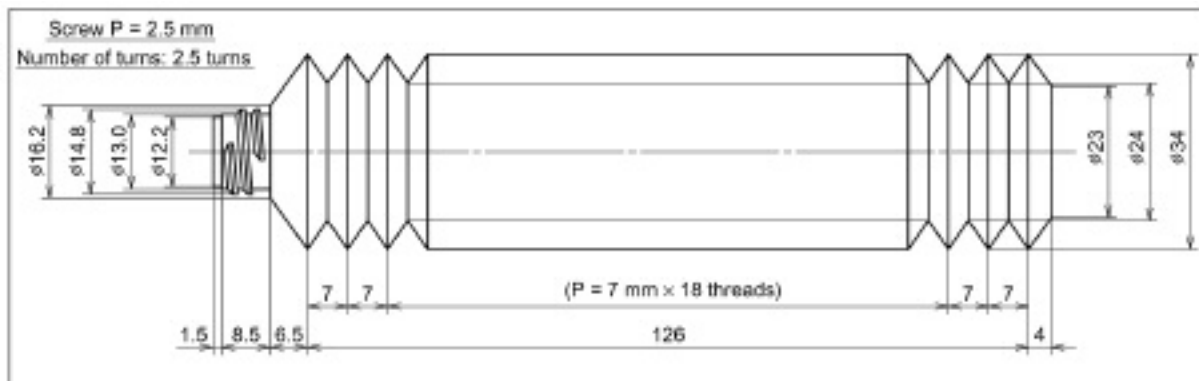

(3) NSK manual Grease Pump Unit

1. NSK Hand Grease Pump Unit (Reference number: NSK HGP)

• Features

- Light-weightCan be operated by one hand, yet there is no worry to making a mistake.
- Inserting by high pressureInsert at 15 Mpa.
- No leaking.....Does not leak when held upside down.
- Easy to change greaseSimply attach the grease in bellows tube.
- Remaining greaseCan be confirmed through slit on the tube.
- Several nozzles.....Five types of nozzles to choose from.

• Specifications

- Spout volume0.35 g/stroke
- Mass of main body393 g
- Overall lengthAbout 200 mm
- Overall width.....About 200 mm
- Grease tube outer diameterø38.1
- Accessory.....Several nozzles for a unique application can be attached

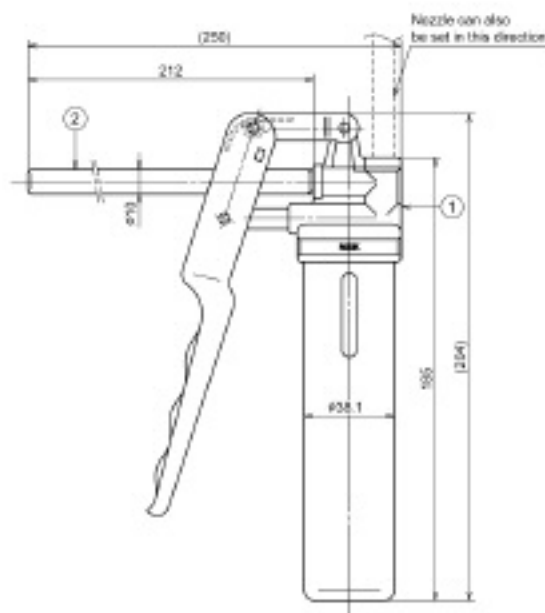

Fig. 2-3 NSK Hand Grease Pump with NSK straightnozzle

(2) Nozzles

Nozzles that can be attached to NSK Hand Grease Pump

Name	Designation code	Use	Dimensions
NSK straight nozzle	aNSK HGP NZ1	Can be used with grease fitting A, B, and C under JIS B1575 standard.	
NSK chuck nozzle	NSK HGP NZ2	Same as above. However, there is no need to press the hand pump because the grease fitting and the nozzle come to contact due to the chucking mechanism at the tip.	
NSK fitting nozzle	NSK HGP NZ3	Dedicated for the - f3 drive-in grease fitting.	
NSK point nozzle	NSK HGP NZ4	Used for linear guides and ball screws which do not have grease fitting. Supplies grease directly to the ball grooves, or through the opening of ball slide or ball slide to inside.	
NSK flexible nozzle	NSK HGP NZ5	The tip of the flexible nozzle is chuck nozzle. Used to supply grease to the area where hand cannot reach.	
NSK flexible extension pipe	NSK HGP NZ6	Flexible extension pipe connects the grease pump and the nozzle	
NSK straight extension pipe	NSK HGP NZ7	Straight extension pipe connects the grease pump and the nozzle.	

Grease lubricant for linear guides and ball screws

Type	Thickener	Base oil	Base oil kinematic viscosity cSt (40°C)	Range of use temperature (°C)	Purpose
AV2	Lithium type	Mineral oil	130	-10~110	For ball screws and linear guides for general use at high load.
PS2	Lithium type	Synthetic oil + mineral oil	15	-50~110	For ball screws and linear guides for low temperature and high frequency operation.
LR3	Lithium type	Synthetic oil	30	-30~130	For ball screws at high speed, medium load.
LG2	Lithium type	Synthetic oil + synthetic hydrocarbon oil	30	-10~80	For ball screws and linear guides for clean environment.
NF2	Urea composite type	Synthetic oil + mineral oil	27	-40~100	For fretting resistant ball screws and linear guides.

Table Grease nozzle used for NSK linear guide

Linear guide model	Tap hole for grease fitting	Standard grease fitting	Straight nozzle NZ1	Chuck nozzles (two) NZ	Drive-in nipple nozzle NZ3	Point nozzle NZ4	Flexible nozzle NZ5
LS15	∅ 3	Drive-in type			o		
LS20 ~35	M6 x 0.75	B type	o	o			o
LH15	∅ 3	Drive-in type			o		
LH20 ~35	M6 x 0.75	B type	o	o			o
LH45 ~85	PT1 / 8	B type	o	o			o
LW17	∅ 3	Drive-in type			o		
LW21 ~35	M6 x 0.75	B type	o	o			o
LW50	PT/18	B type	o	o			o
LU09 ~15	-	None				o*2)	
LE09 ~15	-	None				o*2)	

*1) LU and LE Series: Apply grease directly to ball groove, etc. using a point nozzle.

*2) LS20, LS25, LH20: Use straight nozzle. (Point nozzle tip cannot be used because it interferes with the rail top surface.)

Figures of Grease fittings

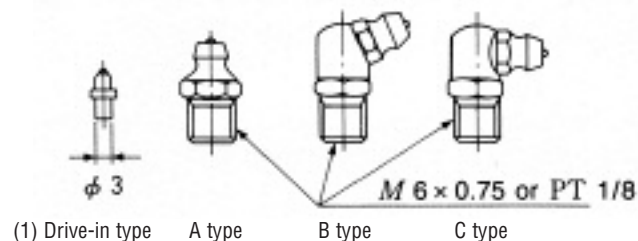

Application Sheet Linear Guides – Rail Butting

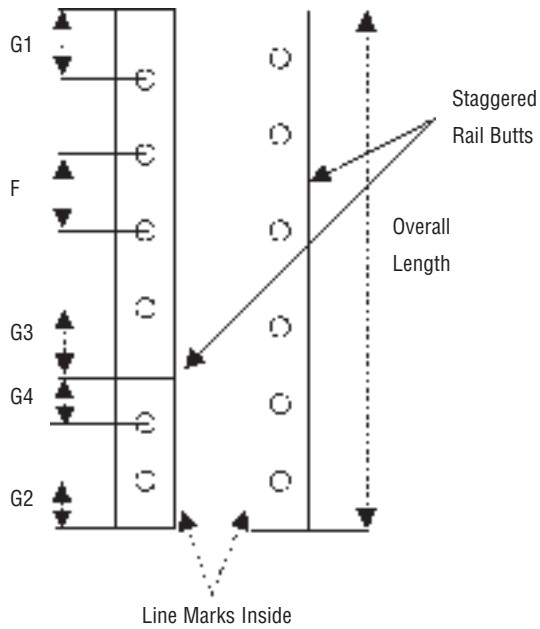

In order to determine rail butting configuration, please photocopy and complete this form from our catalogue and fax back to NSK. An electronic copy is available please contact our customer service.

Quantity _____ Rail Number: _____

G1 Dimension: _____ mm G2 Dimension: _____ mm

F Dimension: _____ mm

Note: For butting rails only.

Note: Make sure line marks are inside for Rail Butting.

Consists of _____ G1= _____ G3= _____

_____ G2= _____ G4= _____

Company: _____

Contact Name: _____

Telephone: _____ Fax: _____

Date: _____ E-Mail: _____

Remarks: _____

K1 Maintenance-Free Lubrication System

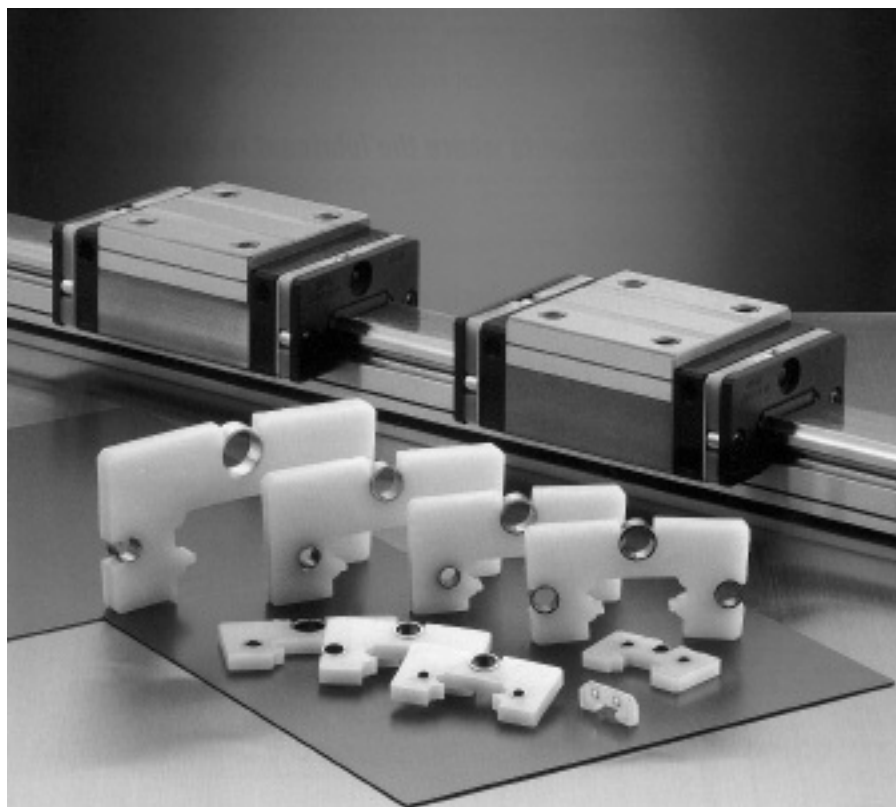

The NSK K1's distinctive capabilities as a compact and efficient oil-impregnated lubrication unit as well as a seal, greatly increases the performance of the Linear Guide. The K1 Lubrication Unit is available in two types, one for industrial applications and one for food and medical devices where cleanliness and safety are paramount.

Features:

1. Long-term, maintenance-free usage.

In mechanical environments where lubrication is difficult to apply, long-term running efficiency is maintained by using the NSK K1 in combination with grease.

2. Prevention of oil-related environmental pollution.

In locations where oil greatly affects the environment, or in mechanisms with severe hygiene restrictions, sufficient lubrication is provided using the NSK K1 in combination with grease.

3. Effective in environments where the lubricant is washed away.

In facilities where mechanisms are washed down with water, or subject to severe weather conditions, long service life is ensured by using the NSK K1 in combination with grease. Especially effective under hygienic conditions where oil must not be dispersed.

4. Maintains efficiency in dusty environments.

In environments where oil and grease-absorbing dust is produced, long-term efficiency is maintained by using the NSK K1 in combination with grease.

K1 Identification Number

Refer to the following numbering system when ordering.

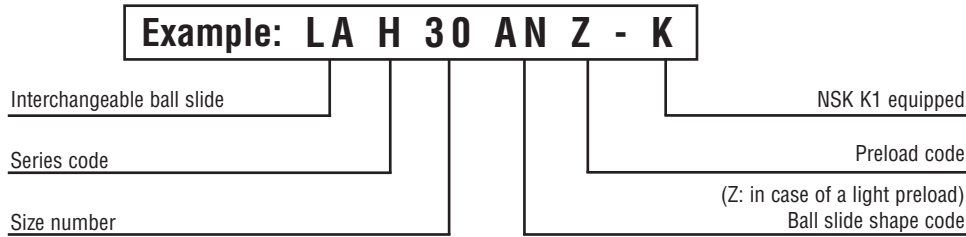

Interchangeable Linear Guide Dimensions – LH, LS, LW, LU, LE Series

Unit: mm

Interchangeable Ball Slide size code	Ball slide form		Standard Ball Slide length	Ball slide length with two NSK K1 L	Thickness of NSK K1 V ₁	Thickness of protective cover V ₂	Grease fitting projection N (mm)	
	AN	EM						
LAH15	AN	EM	55	65.6	4.5	0.8	(5)	
		GM	74	84.6				
LAH20	AN	EM	69.8	80.4	4.5	0.8	(14)	
		GM	91.8	102.4				
LAH25	AN	EM	79	90.6	5.0	0.8	(14)	
		GM	107	118.6				
LAH30	AN	EM	85.6	97.6	5.0	1.0	(14)	
		GM	98.6	110.6				
LAH35	AN	EM	109	122	5.5	1.0	(14)	
		GM	143	156				
LAH45	AN	EM	139	154	6.5	1.0	(15)	
		GM	171	186				
LAH55	AN	EM	163	178	6.5	1.0	(15)	
		GM	201	216				
LAH65**	AN	EM	193	211	8.0	1.0	(16)	
		GM	253	271				
LAS15	AL	EL	FL	56.8	66.4	4.0	0.8	(5)
		CL	KL	40.4	50			
LAS20	AL	EL	FL	65.2	75.8	4.5	0.8	(14)
		CL	KL	47.2	57.8			
LAS25	AL	EL	FL	81.4	92	4.5	0.8	(14)
		CL	KL	59.4	70			
LAS30	AL	EL	FL	96.4	108.4	5.0	1.0	(14)
		CL	KL	67.4	79.4			
LAS35	AL	EL	FL	108	121	5.5	1.0	(14)
		CL	KL	77	90			
LAW17	EL			51.4	61.6	4.5	0.6	(5)
LAW21	EL			58.8	71.4	5.5	0.8	(13)
LAW27	EL			74	86.6	5.5	0.8	(13)
LAW35	EL			108	123	6.5	1.0	(13)
LAW50	EL			140.6	155.6	6.5	1.0	(14)
LAU09	AR	TR		30	36.4	2.7	0.5	–
LAU12	AR	TR		35.2	42.2	3.0	0.5	–
LAU15			AL	43.6	51.8	3.5	0.6	–
LAE09	AR	TR		39.8	46.8	3.0	0.5	–
LAE12	AR			45	53	3.5	0.5	–
LAE15	AR			56.6	66.2	4.0	0.8	–

LH, LS Series

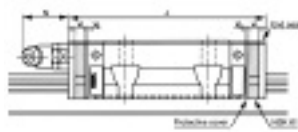

LU, LE Series

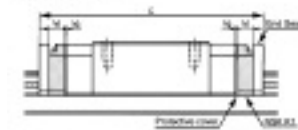

LW Series

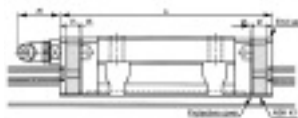

Note: For more bearing seal options see page 4.

* For Protector and Double Seal Information for LH Series please see page 14.

** For Protector and Double Seal Information for LS Series please see page 22.

**Contact NSK for information on assembly instructions.

K1 Lubrication Unit Handling and Assembly Instructions

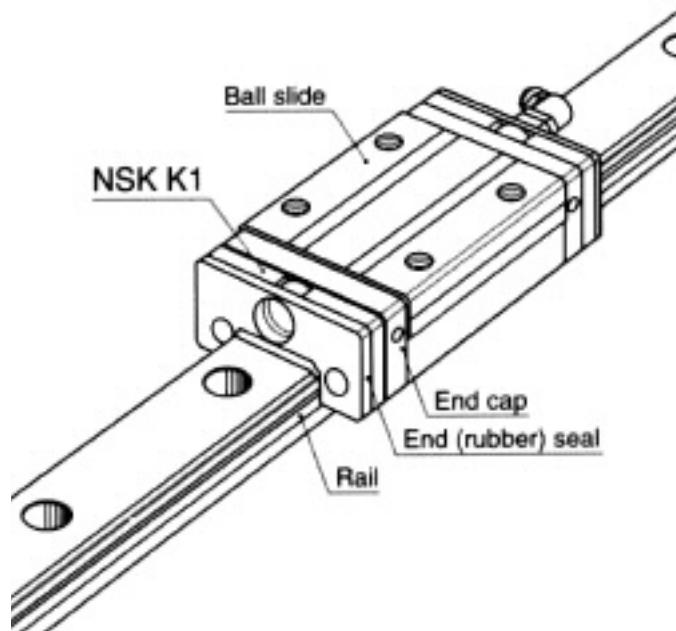

Handling Instructions

To maintain the NSK K1 Seal's high efficiency over a long period of time, please follow these instructions.

1. Permissible temperature range Max. operating temperature: 50°C (122°F) Max. peak temperature: 80°C (176°F) If not installed immediately, they should be kept refrigerated. Avoid storage in direct sunlight.

2. Never leave the linear guide in close proximity to grease-removing organic solvents such as hexane, thinners, etc. Never immerse the linear guide in kerosene or rust preventative oils which contain kerosene.

Note

Other oils such as: water-based cutting oil, oil-based cutting oil, grease (mineral oil-AV2, ester-PS2) present no problems to the K1 lubricating units performance.

Assembly Instructions for the K1 Lubricating Unit for Linear Guides

1. Slide linear bearing on to the linear rail, using the plastic provisional rail supplied.
2. Remove the grease fitting from the end of the bearing.
3. Remove the Phillips screws (2 pieces).
4. Remove the end seal from end of bearing.
5. Install threaded plug from K1 kit (or see option 9 and 10 depending on application).
6. Install the cover plate from the K1 kit, to the end of bearing, against the end cap.
7. Install K1 lubricating unit without fixing rings, so it can be expanded over the rail.
8. Put the three (3) fixing rings in position on the K1 lubricating unit.
9. Replace the end seal, in front of the K1 lubricating unit.
10. Install connector screw for grease fitting.
11. Replace the grease fitting in connector screw.
12. Install the **extension** Phillips screws (2 pieces, supplied with the K1 seal kit).

Note* The K1 lubricating unit has a shelf life. They should be installed immediately upon receipt. It is important to avoid direct sun light and extreme heat conditions.

Unit Conversions To convert

From	To	Multiply By
daN	N	10.000
kgf	N	9.81
kgf	lbf	2.205
kgf.cm	lbf.in	0.868
kgf.cm	ozf.in	13.890
kgf.m	lbf.ft	7.234
kgf.m	lbf.in	86.811
N.m	lbf.ft	0.738
mm	inch	0.03937
inch	mm	25.4

Precision Ground Ball Screws



Precision Ground Ball Screws are designed to ensure smooth, precise travel, reduced wear and longer life. NSK is the leading producer of these precision products. Custom designs can be ordered for demanding applications.

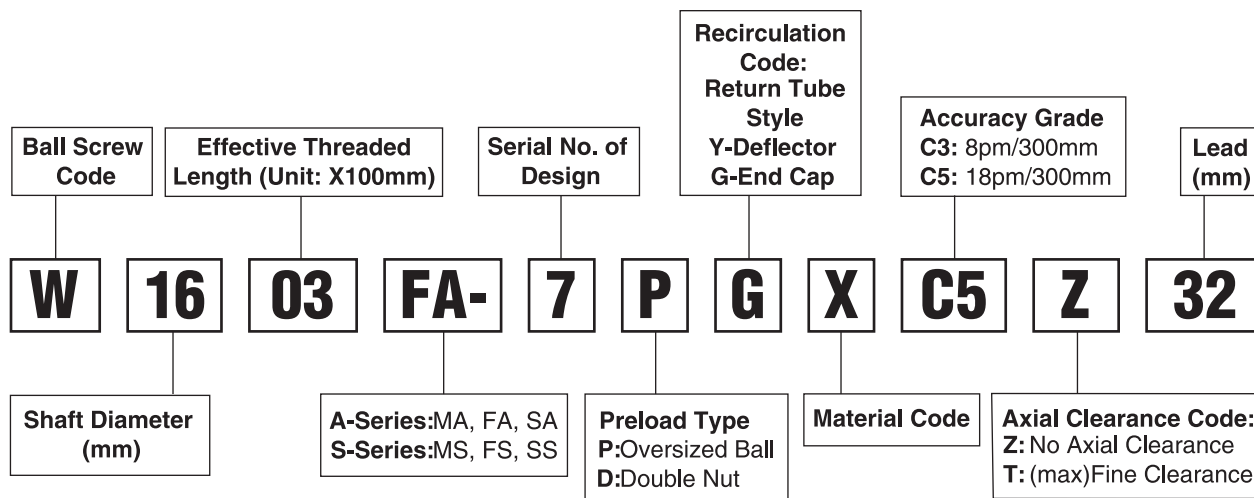

Please refer to the bearing tables for exact part number options.

- In addition to standard ground Ball Screws, NSK offers a complete line of custom Precision Ground Ball Screws.
- NSK also offers a wide variety of either Flange or Square style Ball Screw Support Unit kits.

Standard Metric Precision Ground Ball Screws

- **A-Series**(Finished Shaft Ends)
- **S-Series**(Unmachined Shaft Ends)

Screw Shaft Diameter (mm)	Lead (mm)															
	1	1.5	2	2.5	4	5	6	8	10	12	16	20	25	32	40	50
4	●															
6	●															
8	●	●	●													
10			●	●	○											
12		●	●			○			○							
14						○		○								
15									○			○				
16			●	●		○					○			○		
20					■	■			○			○			○	
25					■		■		■			○	○			○
28						■	■									
32						■	■	■	■				○	○		
36									■							
40						■		■	■	■						
45									■							
50									■							

Legend

Finished S ○ MS,MA
Unmachined A ● BB,SA
 ■ ■ FB,FA

Precision Ground Ball Screws

Standard Inch

Available with either Finished or Unfinished Shaft Ends

Availability Table

Shaft O.D. Lead	.472" (12mm)	.630" (16mm)	.784" (20mm)	.787" (20mm)	.984" (25mm)	1.260" (32mm)	1.496" (38mm)	1.732" (44mm)	1.969" (12mm)
.200" (5.08 mm)	○	○		○	○	○	■	■	■
.250" (6.35 mm)					■		■	■	■
.500" (12.7 mm)		■	○	■	○	○	■	■	■
1.00" (25.4 mm)					○	■	■		

■ Unmachined Shaft Ends ○ Machined Shaft Ends

Identification Numbers

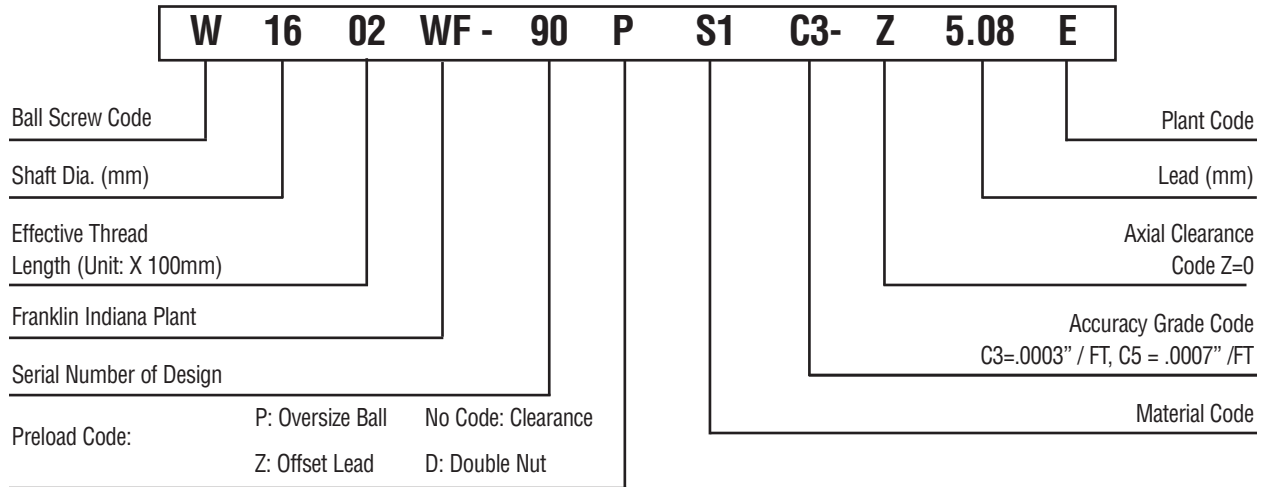

- NSK offers a wide variety of standard “off the shelf” ball screw support unit kits
- NSK’s standard line of both metric and inch series precision ground ball screws are manufactured to either a C3 or C5 accuracy grade.

Introduction

Ball Bearings

Cylindrical Roller Bearings

Spherical Roller Bearings

Tapered Roller Bearings

Thrust Bearings

Split Pillow Blocks

Super Precision Bearings

Linear Motion

Rolling Mill Bearings

Engineering Section





Rolled Ball Screw

R Series

(1) Product classification

NSK rolled ball screws are classified by nut model as shown in Table I-6.4.

Table I-6•4 Classification of rolled ball screws

Nut model	Nut shape	Recirculation system	Lead classification	Page
RNFTL		Return tube type	Fine, medium lead	B257
			High helix lead	B261
RNFBL		Return tube type	Fine, medium lead	B263
RNCT		Return tube type	Fine lead	B265
RNSTL		Return tube type	Small, medium leads	B267
RNFCL		End cap type	High helix lead	B269
			Ultra high helix lead	B271

(References below are in Catalog E3161)

(2) Features

- Short delivery time: R Series is standardized, and available in stock.
- Interchangeable screw shaft and ball nut: Screw shaft and nut assembly components are sold separately, and randomly-matched. The maximum axial play after assembly is shown in the dimension tables (from Page B257 ~ B272).
- Low prices: Screw shaft is processed by rolling. This is why prices are lower than those of precision types.
- Abundant series: There are 128 types of nut assembly combinations in the series. Each combination has two to three different lengths in screw shaft.

(3) Accuracy

- ◇ Lead accuracy: Ct10 grade ($u_{300}=0.210$). Refer to "Technical Description: Lead Accuracy" (Page B499) for details.

- ◇ Axial play: Varies with internal specification. Refer to the dimension tables (Page B257).
- ◇ Run out of screw shaft center: Ct10 grade

(4) Nut installation

Refer to "Technical Description: Installation" (Page B529).

(5) Shaft end machining

It is necessary to machine screw shaft end of the rolled ball screw.

Refer to "Configuration of rolled ball screw shaft end" (Page B29) if you use standard support unit. Refer to "Technical Description: Shaft end machining" (Page B537) for procedures and precautions.

(6) Rust prevention

Rust prevention agent is applied at time of delivery. But special surface treatment is not given to these ball screws.

Rolled Ball Screw

R Series

NSK furnishes treatment such as phosphate coating or electrolysis low temperature chrome plating on request.

(7) Reference number

Reference number of rolled ball screw is described below. Please use reference number to order, or for a price inquiry.

Nut assembly (example)

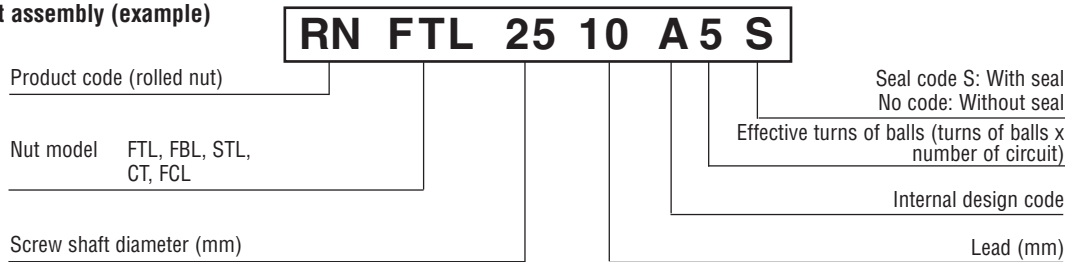

Screw shaft (example)

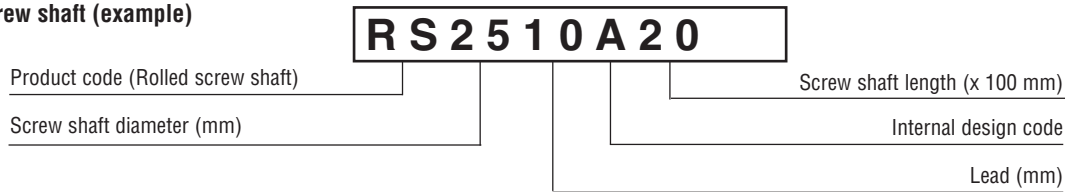

(8) Combinations of shaft diameter/lead

Combinations are shown below in Table I-6.5. The table also indicates nut model codes and page numbers to be referred.

Table I-6.5 Combinations of shaft diameter/lead (References below are in Catalog E3161)

Screw shaft diameter (mm)	Lead (mm)														
	3	4	5	6	8	10	12	16	20	25	32	40	50	64	80
10	○B257 △B265			○B257 ●B263											
12					○B257 ●B263		○B261 ○B269								
14		○B257 ●B263 △B265 □B267	○B257 ●B263 △B265 □B267												
15									○B269						
16						○B257		○B261 ○B269		○B271					
18				○B257 ●B263 △B265 □B267											
20			○B257 ●B263 △B265 □B267			○B257 ●B263 △B265 □B267			○B261 ○B269			○B271			
25			○B257 ●B263 △B265 □B267			○B257 ●B263 △B265 □B267				○B261 ○B269			○B271		
28				○B257 ●B263 △B265 □B267											
32											○B261 ○B269			○B271	
36															
40												○B261 ○B269			○B271
45								○B259 △B265 □B267							
50						○B259		○B259 △B265					○B269		

○:RNFTL ●:RNFBFL △:RNCT □:RNSTL ○:RNFCL

Ball Screw Support Bearing

B-I-6.6 Accessories

Accessories to use with ball screw are available in stock.

Table I-6•6 Support unit categories (References below are in Catalog E3161)

Application	Shape	Support side	Bearing in use	Bearing bore Bearing seat diameter	Page
Small equipment, light load	Square	Fixed support side	Angular contact ball bearing	ø6~ø25	B277 ~
		Deep groove ball bearing	ø12, ø15 <small>(Exclusive for VFA Series)</small>	B291	
	Round	Fixed support side	Deep groove ball bearing (arranged to have angular contact)	ø4, ø6 <small>(Exclusive for RMA and RMS Series)</small>	B293
			Angular contact ball bearing	ø6~ø25	B277 ~
	Machine tools, heavy load	Round	Fixed support side	Thrust angular contact ball bearing	ø17~ø40

Introduction
Ball Bearings
Cylindrical Roller Bearings
Spherical Roller Bearings
Tapered Roller Bearings
Thrust Bearings
Split Pillow Blocks
Super Precision Bearings
Linear Motion
Rolling Mill Bearings
Engineering Section

(1) Support units

1. Classification

Ball screw support units are classified into categories by their shape (Table I-6.6). Select the type that is appropriate for you to use.

2. Features

- Short delivery time: Standardized items in stock
- Use most suitable bearings
On the fixed support side, the angular contact ball bearing is used. It has great rigidity and low friction torque which match the rigidity of the ball screw. The thrust angular contact ball bearing with high precision and great rigidity is another choice for the fixed support side.
- High dust prevention, and low friction torque
Oil seal is installed in small clearance on the fixed support side. A deep-groove ball bearing with a shield on both sides is used on the simple support side. This minimizes friction torque.
- Lock nut is provided.
A lock nut of fine grade finish is provided to fix the bearing with high precision.

3. Reference number and applicable ball screw

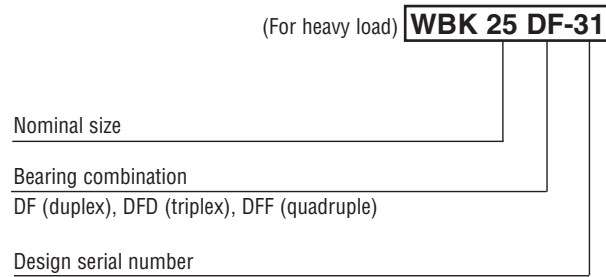
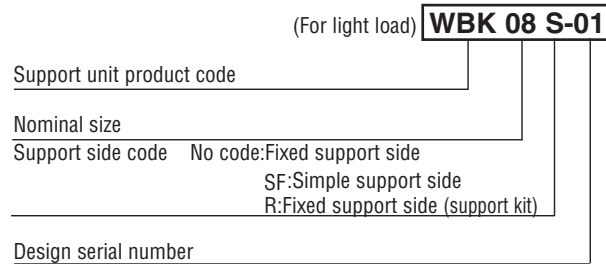

Introduction
Ball Bearings
Cylindrical Roller Bearings
Spherical Roller Bearings
Tapered Roller Bearings
Thrust Bearings
Split Pillow Blocks
Super Precision Bearings
Linear Motion
Rolling Mill Bearings
Engineering Section

Table I-6•7 and 8 show "shaft diameter/lead combinations" of standard ball screws that are applicable to support units.

Table I-6•7 Support units for light load and applicable "screw shaft diameter/lead combinations"

Light load / small equipment	Support unit / reference number			"Screw shaft diameter/lead combinations" of standard ball screws that are applicable to support unit (mm)
	Square		Round	
	Fixed support side (driving motor side)	Simple support side (opposite to driving motor)	Fixed support side	
	WBK06-01A	—	WBK06-11	
WBK08-01A	WBK08S-01	WBK08-11	ø8x1, ø8x1.5, ø8x2, ø10x2, ø10x2.5	
WBK10-01A	WBK10S-01	WBK10-11	ø10x4, ø12x2, ø12x2.5, ø12x5, ø12x10	
WBK12-01A	WBK12S-01	WBK12-11	ø14x5, ø14x8, ø15x10, ø15x20, ø16x2 ø16x2.5, ø16x5, ø16x16, ø16x32	
WBK15-01A	WBK15S-01	WBK15-11	ø20x4, ø20x5, ø20x10, ø20x20, ø20x40	
WBK20-01	WBK20S-01	WBK20-11	ø25x4, ø25x5, ø25x6, ø25x10, ø25x20 ø25x25, ø25x50, ø28x5, ø28x6	
WBK25-01	WBK25S-01	WBK25-11	ø32x5, ø32x6, ø32x8, ø32x10 ø32x25, ø32x32	

Remarks 1. Reference number is based on the bearing bore on the fixed support side.
2. Please note that the reference numbers 12 or below on the simple-support side do not match the bore of the deep-groove ball bearing in use.

Table I-6•8 Support units for heavy load and applicable "screw shaft diameter/lead combinations"

Heavy load / machine tools	Support unit / reference number		"Screw shaft diameter/lead combinations" of standard ball screws that are applicable to the support unit (mm)
	Fixed support side (drive motor side)	Fixed support side (opposite to drive motor)	
	WBK30DF-31	WBK25DF-31	
WBK30DFD-31	WBK25DFD-31	ø36x10, ø40x10	
WBK30DF-31	WBK30DF-31	ø40x5, ø40x8, ø40x10, ø40x12	
WBK30DFD-31	WBK30DFD-31	ø40x12	
WBK35DF-31	WBK35DF-31	ø45x10	
WBK40DF-31	WBK40DF-31	ø50x10	
WBK40DFD-31	WBK40DFD-31	ø50x10	

※ Refer to Page B27 for shaft end configuration to use support units.

4. Dimensions of support unit for light load / small equipment

Table I-6•9 shows characteristic value of the support units for light load / small equipment.

Table I-6•9 Characteristic values of support units for light load

Support unit reference number	Fixed side support unit						Support unit on simple support side		
	Bearing in use (angular contact ball bearing)						Bearing in use (deep-groove ball bearing)		Support unit reference number
	Bearing reference number	Axial direction				Maximum starting torque (N·É·m)	Bearing reference number	Radial direction	
Basic dynamic load rating (C _a N)		Load limit (N)	Preload (N)	Rigidity (N/É·m)	Basic dynamic load rating C N				
WBK06-01A (Square) WBK06-11 (Round)	706ATYDFC7P5	2670	1040	20	28	0.49	—	—	—
WBK08-01A (Square) WBK08-11 (Round)	708ATYDFC8P5	4400	1450	59	53	0.88	606ZZ	2260	WBK08S-01 (Square type)
WBK10-01A (Square) WBK10-11 (Round)	7000ATYDFC8P5	6600	2730	205	94	1.9	608ZZ	3300	WBK10S-01 (Square type)
WBK12-01A (Square) WBK12-11 (Round)	7001ATYDFC8P5	7100	3040	215	104	2.1	6000ZZ	4550	WBK12S-01 (Square type)
WBK15-01A (Square) WBK15-11 (Round)	7002ATYDFC8P5	7600	3380	235	113	2.3	6002ZZ	5600	WBK15S-01 (Square type)
WBK20-01 (Square) WBK20-11 (Round)	7204ATYDFC8P5	17900	8240	440	155	5.4	6204ZZ	12800	WBK20S-01 (Square type)
WBK25-01 (Square) WBK25-11 (Round)	7205ATYDFC8P5	20200	10000	580	192	7.2	6205ZZ	14000	WBK25S-01 (Square type)
WBK04R-11 (Round)	F694ZZ (Deep-groove ball bearing)	615	490	—	6.5	0.59	—	—	—
WBK06R-11 (Round)	F696ZZ (Deep-groove ball bearing)	1280	930	—	9	0.59	—	—	—



* NSK does not recommend replacing only the bearing within a unit. We recommend the replacement of a complete unit. Please contact NSK for availability.

MCM & MCH Series Monocarrier®

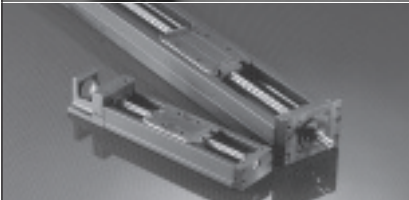
C-I-1 Appearance

Item	Appearance	Outline	Main application
Monocarrier		A single axis unit combines a ball screw, a linear guide and a support bearing unit for ease of design and assembly loads of a machine. Both MCM and MCH type Monocarriers equip with NSK K1 lubrication unit, which enables long term maintenance free operation, as the standard feature.	<ul style="list-style-type: none"> • Automotive manufacturing equipment • Manufacturing machine for semiconductors and liquid crystal displays • Food processing / medical equipment • Optical / glass working machines • Telecommunication manufacturing equipment
			

C-I-2 MCM Type and MCH Type

Item	Appearance	Outline	Main application
MCM		Light weight is the special feature of this type of Monocarrier. It suits well for a vertical axis of material handling robots.	<ul style="list-style-type: none"> • Equipment that needs to reduce the weight: • Substitution for pneumatic actuator • Robots • Transporting equipment • Measuring machine • Equipment for factory automation etc.
MCH		Distinctive feature of Monocarrier is stiff rail. It can be a beam by itself.	<ul style="list-style-type: none"> • Equipment that needs to reduce the weight: • Substitution for pneumatic actuator • Robots • Transporting equipment • Measuring machine • Equipment for factory automation etc.

Introduction

Ball Bearings

Cylindrical Roller Bearings

Spherical Roller Bearings

Tapered Roller Bearings

Thrust Bearings

Split Pillow Blocks

Super Precision Bearings

Linear Motion

Rolling Mill Bearings

Engineering Section

MCM Type Monocarrier®

C-II-1 Configuration of Reference Number

The reference number of Monocarrier Maintenance-free Series describes of main basic specifications.

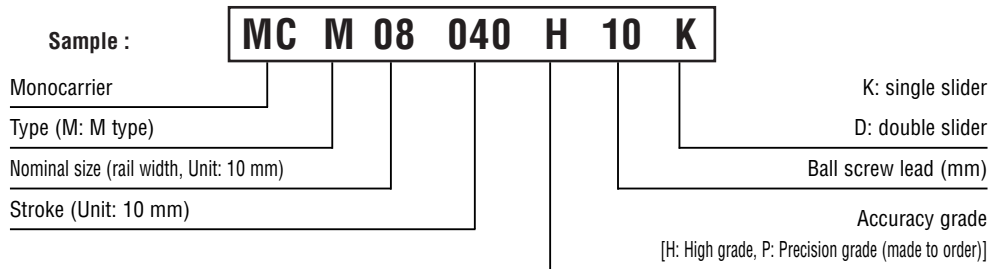

MCM03
Mass 0.7 kg
(100 mm stroke product)

(Lead 1 or 2 mm)

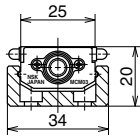

MCM05
Mass 2.7 kg
(400 mm stroke product)

(Lead 10 or 12 mm)

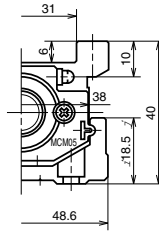
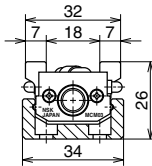

MCM06
Mass 5.2 kg
(400 mm stroke product)

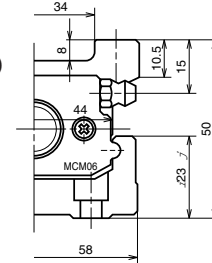

MCM08
Mass 7.4 kg
(400 mm stroke product)

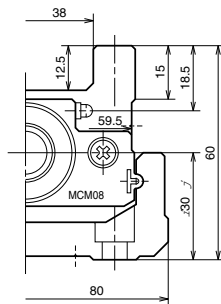

MCM10
Mass 13.0 kg
(400 mm stroke product)

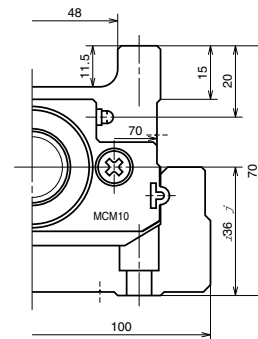

Introduction
 Ball Bearings
 Cylindrical Roller Bearings
 Spherical Roller Bearings
 Tapered Roller Bearings
 Thrust Bearings
 Split Pillow Blocks
 Super-Precision Bearings
 Linear Motion
 Rolling Mill Bearings
 Engineering Section

C-II-2 Standard Combination of Stroke and Ball Screw Lead

In order to meet customer requests for fast delivery, three types of ball screw lead are available as standard: 5, 10 and 20 mm. The accuracy grade of high grade (H) products are also provided as standard inventory by combination of stroke and lead as shown in Table B-I-4.1, For MCM03, leads of 1, 2, 10 and 12 mm are available.

In order to increase rigidity and load capacity of linear guides, double slider specification with an additional sub-slider, which simply functions as a ball slide of linear guide, are set as standard specification. Table B-II-2.2 shows available combinations of model number and stroke. (Double slider specification is not standard for MCM03.)

Table C-II-2-1 Stroke and lead of products with a single slider as a standard specification

● mark: standard inventory, ○ mark: made to order Unit: mm

Nominal size Lead Stroke	MCM03			MCM05			MCM06			MCM08			MCM10		
	1	2	10	12	5	10	20	5	10	20	5	10	20	10	20
50	●	●	-	-	○	●	-	○	○	-	○	-	-	-	-
100	●	●	●	●	○	-	-	●	●	-	○	-	●	-	-
150	○	○	○	○	○	●	-	-	-	-	○	-	-	-	-
200	-	-	●	○	○	●	-	●	●	-	○	●	-	●	-
250	-	-	○	○	-	●	-	-	-	-	-	-	-	-	-
300	-	-	-	-	-	●	●	●	●	●	-	●	●	●	●
400	-	-	-	-	-	●	●	●	○	●	-	●	●	●	●
500	-	-	-	-	-	●	●	○	○	-	-	○	●	○	○
600	-	-	-	-	-	●	○	-	○	○	-	●	○	●	○
700	-	-	-	-	-	-	-	-	●	●	-	○	○	○	○
800	-	-	-	-	-	-	-	-	○	○	-	○	○	●	○
900	-	-	-	-	-	-	-	-	-	-	-	-	-	○	○
1000	-	-	-	-	-	-	-	-	-	-	-	-	-	○	○

Table C-II-2-2 Products with a double slider as a standard specification

○ mark: made to order Unit: mm

Nominal size Lead Stroke	MCM05		MCM06			MCM08		MCM10	
	10	20	5	10	20	10	20	10	20
60	○	-	-	-	-	-	-	-	-
70	-	-	-	-	-	-	-	-	○
80	-	-	-	-	-	○	-	-	-
110	○	-	○	○	-	-	-	-	-
160	○	-	-	-	-	-	-	-	-
170	-	-	-	-	-	-	-	-	○
180	-	-	-	-	-	-	○	○	-
210	○	○	○	○	○	-	-	-	-
270	-	-	-	-	-	-	-	-	○
280	-	-	-	-	-	-	○	○	-
310	○	○	○	○	○	-	-	-	-
370	-	-	-	-	-	-	-	-	○
380	-	-	-	-	-	-	○	○	-
410	○	○	○	○	○	-	-	-	-
470	-	-	-	-	-	-	-	-	○
480	-	-	-	-	-	-	○	○	-
510	○	○	-	○	○	-	-	-	-
570	-	-	-	-	-	-	-	-	○
580	-	-	-	-	-	-	○	○	-
610	-	-	-	○	○	-	-	-	-
670	-	-	-	-	-	-	-	-	○
680	-	-	-	-	-	-	○	○	-
710	-	-	-	○	○	-	-	-	-
870	-	-	-	-	-	-	-	-	○

C-II-3 Accuracy Grade

The accuracy grade of Monocarrier standard inventories is high grade(H). Please contact NSK for details on precision grade (P).

Table C-II-3-1 Accuracy standard

Unit: μm

Grade	High grade (H)			Precision (P)				
	Stroke (mm)	Repeatability	Running parallelism (vertical)	Backlash	Repeatability	Positioning accuracy	Running parallelism (vertical)	Backlash
50	±10	±10	14	20 or less	±3	20	8	3 or less
100								
150								
200								
250								
300								
400								
500								
600								
700								
800	23							
900								
1000								
1000								

NSK evaluation system is adopted.

MCM Type Monocarrier®

C-II-4 Basic Load Rating

Table II-4 • 1 Basic load rating

	Lead mm	Shaft dia. mm	Basic dynamic load rating (N)				Basic static load rating (N)		
			Ball screw	Linear guides*	Support unit	Rated running distance Km	Ball screw	Linear guide*	Support unit
MCM03	1	ø6	735	10900	2670	1	1230	4900	1040
	2	ø6	735	8650	2670	2	1230	4900	1040
	10	ø8	1230	6250	2670	10	1690	6620	1040
	12	ø8	1230	5880	2670	12	1690	6620	1040
MCM05	5	ø12	3760	15600	4400	5	6310	10900	1450
	10	ø12	2260	12400	4400	10	3780	10900	1450
	20	ø12	2260	9850	4400	20	3780	10900	1450
MCM06	5	ø16	7310	25200	6550	5	13500	17000	2730
	10	ø15	7060	20000	6550	10	12700	17000	2730
	20	ø15	4560	15900	6550	20	7750	17000	2730
MCM08	5	ø15	7310	30800	7100	5	13500	22800	3040
	10	ø15	7060	24400	7100	10	12700	22800	3040
	20	ø15	4560	19400	7100	20	7750	22800	3040
MCM10	10	ø20	10900	33500	7600	10	21700	29400	3380
	20	ø20	7060	26600	7600	20	12700	29400	3380

Note

•Basic dynamic and static load ratings indicate the values for one slider. •Basic dynamic load rating of the linear guide is the load of perpendicular direction to the axis that allows 90% of a group of the same Monocarriers to operate "Rated running distance*" in the table, that is equivalent to 1 million revolutions of the ball screw and the support unit, under the same condition without causing flaking by rolling contact fatigue. •Basic dynamic load rating of the ball screw is a load to axial direction that allows 90% of ball screws of a group of the same Monocarriers to rotate 1 million revolutions under the same condition without causing flaking by rolling contact fatigue. •Basic dynamic load rating of the support unit is a constant load to axial direction that allows 90% of support units of the same group of Monocarriers to rotate 1 million revolutions under the same condition without causing flaking by rolling contact fatigue. •Basic static load rating is a load that results in combined permanent deformations at the contact points of balls and ball grooves of respective parts is 0.01 % of the ball diameter.

Table II-4 • 2 Basic static moment load of linear guide

	Lead mm	Slider	Basic static moment (N•m)		
			Rolling (M_{R0})	Pitching (M_{P0})	Yawing (M_{Y0})
MCM03	1, 2	Single	68	28	28
	1, 2	Double	136	198	198
	10, 12	Single	92	51	51
	10, 12	Double	184	315	315
MCM05	5, 10, 20	Single	229	89	89
	5, 10, 20	Double	455	765	765
MCM06	5, 10, 20	Single	415	174	174
	5, 10, 20	Double	825	1220	1220
MCM08	5, 10, 20	Single	770	300	300
	5, 10, 20	Double	1540	2050	2050
MCM10	10, 20	Single	1170	425	425
	10, 20	Double	2340	2940	2940

•Basic static moment of double slider is a value when two sliders equipped with NSK K1 are butted against each other.
 •The basic static moment is the value when a rolling contact pressure of balls exceeds 4000 N/mm².
 •If you require to apply extremely heavy load, consult NSK for estimation of fatigue life.

C-III MCH Type Monocarrier®

C-II-1 Configuration of Reference Number

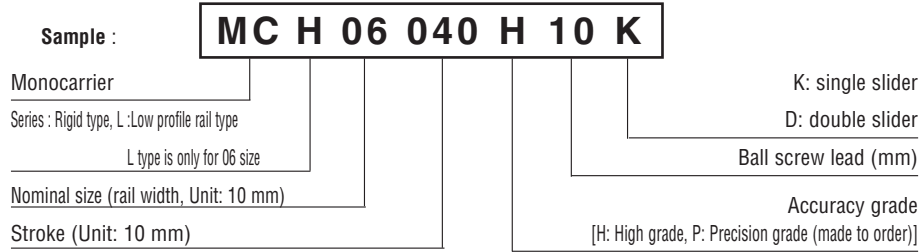

Cross section of each model

MCH06

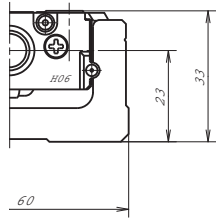

MCL06

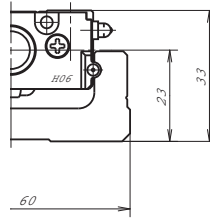

MCH09

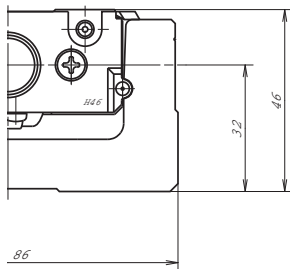

MCH10

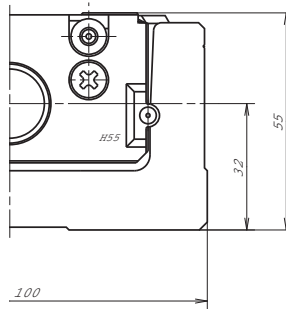

Mounting dimensions of MCL06 are the same as those of MCH06. Only rail height differs. It suits for application such as an end effector of robot that requires a lightweight actuator.

MCH Type Monocarrier®

C-III-2 Standard Combination of Stroke and Ball Screw Lead

MCH06				MCH09				MCH10		
Lead mm	5	10	20	Lead mm	5	10	20	Lead mm	10	20
Stroke mm				Stroke mm				Stroke mm		
50	●	●	○	200	●	●	○	400	●	●
100	●	●	○	300	●	●	○	500	●	●
200	●	●	○	400	●	●	○	600	●	●
300	○	●	●	500	○	●	●	700	●	●
400	○	●	●	600	○	●	●	800	●	●
500	○	●	●	700	○	●	●	900	○	●
								1 000	○	●
								1 100	○	○
								1 200	○	○
								1 800	○	○

MCL06		
Lead mm	10	20
Stroke mm		
50	○	○
100	○	○
200	○	○
300	○	○
400	○	○
500	○	○

● mark : standard inventory ○ mark : made to order *Double slider is available upon request. (made to order)

C-III-3 Accuracy

Table I-3 Accuracy standard

Unit: μm

Grade	Stroke (mm)	High grade (H)			Precision (P)		
		Repeatability	Running parallelism (vertical)	Backlash	Repeatability	Positioning accuracy	Running parallelism (vertical)
~150	±10	±10	20 or less	±3	3 or less	20	8
200						25	10
300						30	12
400							
500						35	15
600							
700							
800						40	20
900							
1000							
1100							
1200							

C-III-4 Load Rating

Ball Screw No.		Code	Unit	MCH06 (MCL06)			MCH09			MCH10		
Linear guide specification	Ball Screw lead	l	mm	5	10	20	5	10	20	10	20	
	Rated running distance*	L_a	Km	5	10	20	5	10	20	10	20	
	Basic dynamic load rating	C_a	N	22 800	18 100	14 400	52 600	32 200	25 500	44 600	35 400	
	Basic static load rating	C_{0a}	N	16 300			30 500			42 000		
	Single	Dynamic moment	M_{RD}	Nm	335			890			1,460	
			M_{PD}	Nm	133			385			610	
			M_{VD}	Nm	133			385			610	
	Double	Static moment	M_{RD}	Nm	770			1 780			2 920	
			M_{PD}	Nm	730			2 070			3 430	
			M_{VD}	Nm	730			2 070			3 430	
Ball screw specification	Shaft dia.	mm		12	12	12	15	15	15	20	20	
	Lead	mm		5	10	20	5	10	20	10	20	
	High grade	Basic dynamic load rating	C_a	N	3 000	1 930	1 930	6 820	5 110	3 290	8 230	5 300
		Basic static load rating	C_{0a}	N	5 410	3 160	3 160	13 200	9 290	5 620	17 100	10 300
	Accuracy	Basic dynamic load rating	C_a	N	3 760	2 260	2 260	7 100	7 060	4 560	10 900	7 060
		Basic static load rating	C_{0a}	N	6 310	3 780	3 780	13 000	12 700	7 750	21 700	12 700
Support unit specification	Fixed	Model No.	WBK08			WBK12			WBK15			
		Basic dynamic load rating	C_a	N	4 400			7 100			7 600	
		load limit	C_{0a}	N	1 450			3 040			3 380	
	Simple support	Model No.	696ZZ			6900ZZ			6901ZZ			
		Basic dynamic load rating	C_a	N	1 730			2 700			2 890	
Dynamic torque	Single	N • cm		1.0~4.8	1.1~5.8	1.6~7.9	1.0~5.9	2.0~7.8	2.0~10.8	2.7~10.8	3.1~12.7	
	Double	N • cm		1.2~5.2	1.5~9.6	2.3~11.8	1.5~7.0	2.5~10.8	4.0~17.2	4.2~15.6	5.0~19.6	

Note:

•Basic dynamic and static load ratings indicate the values for one slider. •Basic static moment of double slider is a value when two sliders equipped with NSK K1 are butted against each other. •Basic dynamic load rating of the linear guide is the load of perpendicular direction to the axis that allows 90% of a group of the same Monocarriers to operate "Rated running distance*" in the table, that is equivalent to 1 million revolutions of the ball screw and the support unit, under the same condition without causing flaking by rolling contact fatigue. •Basic dynamic load rating of the ball screw is a load to axial direction that allows 90% of ball screws of a group of the same Monocarriers to rotate 1 million revolutions under the same condition without causing flaking by rolling contact fatigue. •Basic dynamic load rating of the support unit is a constant load to axial direction that allows 90% of support units of the same group of Monocarriers to rotate 1 million revolutions under the same condition without causing flaking by rolling contact fatigue. •Basic static load rating of each part is a load that results in combined permanent deformations at the contact points of balls and ball grooves of respective parts is 0.01 % of the ball diameter. •The basic static moment is the value when a rolling contact pressure of ball grooves is 4000 N/mm². This is allowable static contact pressure of the Monocarrier linear guide.

Introduction

Ball Bearings

Cylindrical Roller Bearings

Spherical Roller Bearings

Tapered Roller Bearings

Thrust Bearings

Split Pillow Blocks

Super Precision Bearings

Linear Motion

Rolling Mill Bearings

Engineering Section

Table of Contents Rolling Mill Bearings

INTRODUCTION	
About NSK Rolling Mill Bearings	283
NOMENCLATURE	
Four Row Roller Bearings	284
Two Row Tapered Roller Bearings	284
Angular Contacts	285
APPLICATION	
Rolling Mill Bearings	286

Introduction
Ball Bearings
Cylindrical Roller Bearings
Spherical Roller Bearings
Tapered Roller Bearings
Thrust Bearings
Split Pillow Blocks
Super Precision Bearings
Linear Motion
Rolling Mill Bearings
Engineering Section

Introduction

ABOUT NSK ROLLING MILL BEARINGS

- Four Row Tapered Roller Bearings
- Four Row Cylindrical Roller Bearings
- Two Row Tapered Roller Bearings
- Angular Contact Ball Bearings

Four Row Tapered roller bearings are very popular for use on roll necks. Most of these bearings are composed of two double cones (four Inner ring raceways), a cone spacer, two single cups (one at each end), one double cone (the center two raceways in the outer rings), and two cup spacers. They are very effective at operating under heavy radial and axial loads at low to moderate speeds. NSK four row tapered bearings are standardly supplied with carburized rings and rollers and are compatible with industry standards. "Sealed-Clean" bearings are four row tapers with seals for the harshest of operating environments. NSK's patented design provides the optimum sealing efficiency with only a slight loss of capacity.

Four Row Cylindrical roller bearings are also popular roll neck bearings providing several benefits. First, the inner ring is separable from the outer ring and rollers which allows the inner ring to remain with the roll during grinding processes. This assures precise concentricity and negligible run-out providing for high rolling accuracy. Secondly, this design allows for greater radial load carrying and higher operating speeds. Four row cylindricals require a thrust bearing which is usually a two row taper, angular contact ball bearing, or a deep groove ball bearing depending on the thrust load present.

Two Row Tapered roller bearings are very common as the back-up thrust bearing in a rolling mill or as the roll neck in lighter duty rolling mills. Two row tapers are designed in a variety of styles for different applications. Converging bearings (TDI,TDIE,TDIS) consist of one double cone and two single cups possibly with a cup spacer. Diverging bearings (TDO,TDOD,TDOC) consist of two single cones, a cone spacer, and one double cup.

Angular Contact ball bearings are used as thrust bearings for roll necks using four row cylindricals and having lighter load requirements. These bearings can only accept axial loads in one direction so they are used in sets of two with the contact angles diverging.

Nomenclature — Four Row Roller Bearings

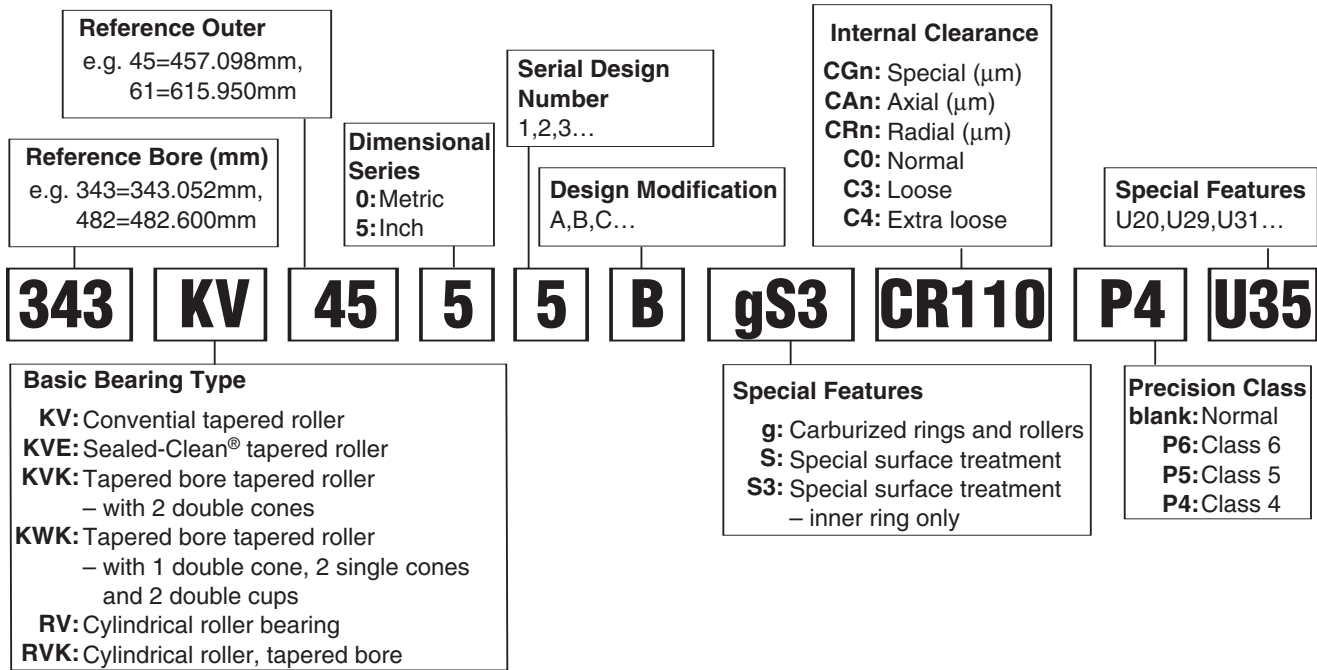

Nomenclature — Two Row Tapered Roller Bearings

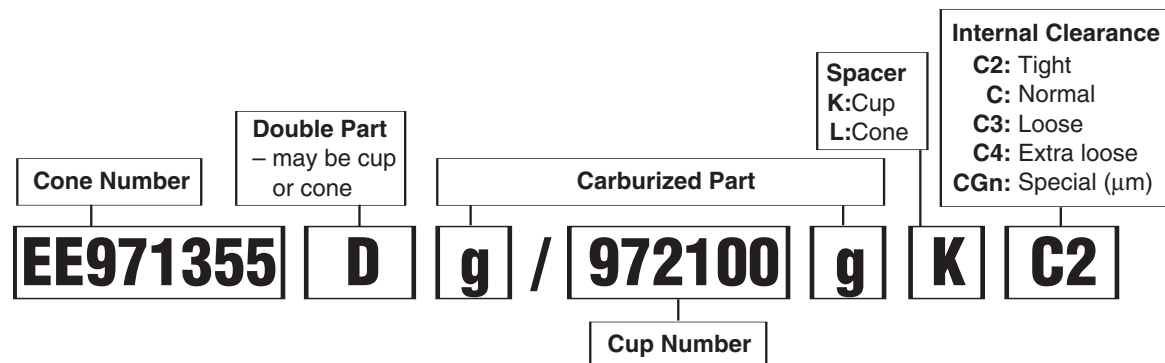
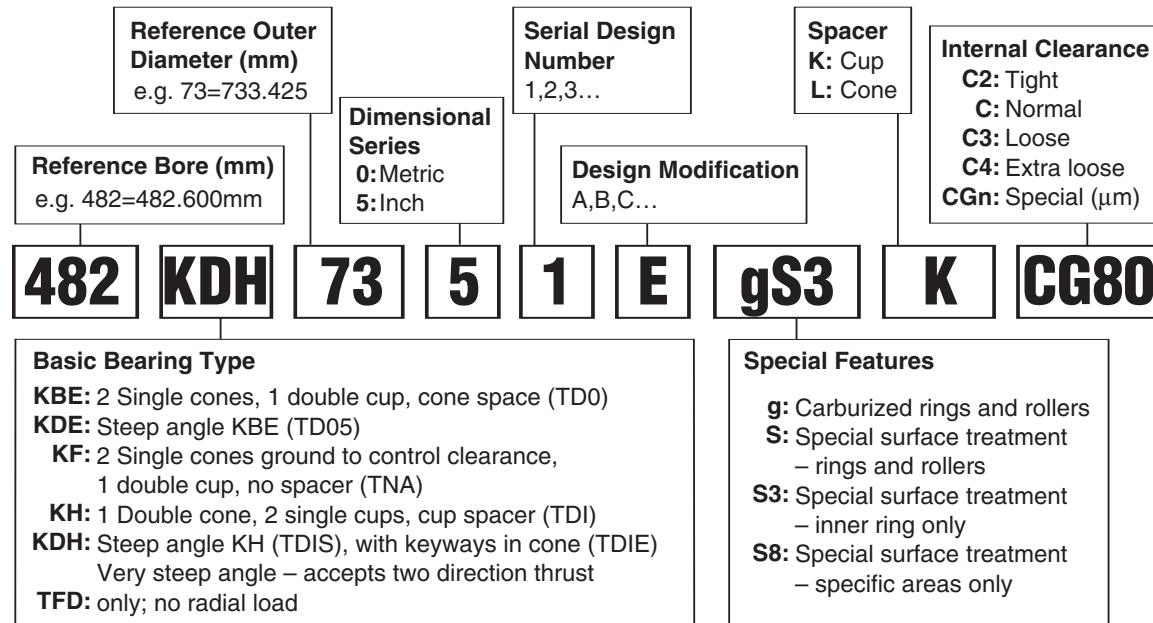

Nomenclature — Angular Contacts

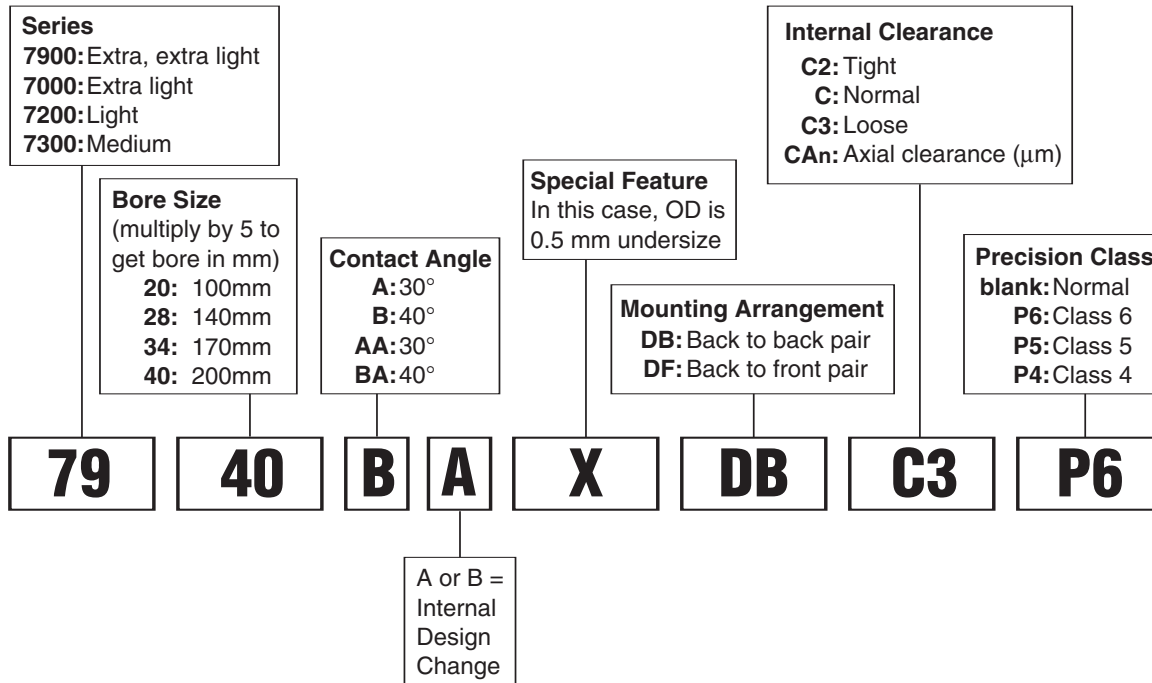
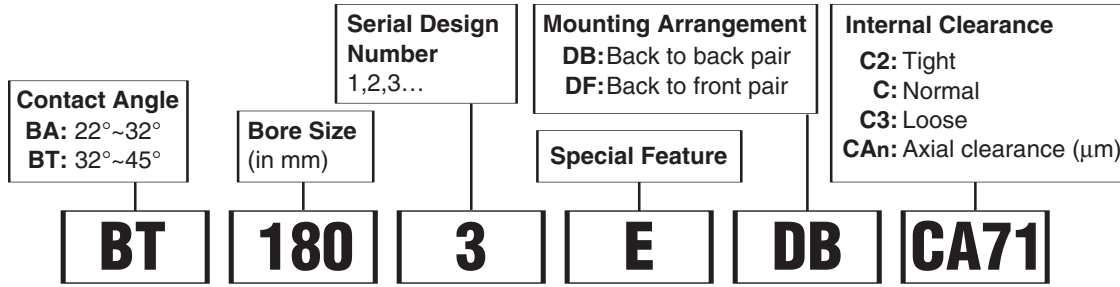

Introduction

Ball Bearings

Cylindrical Roller Bearings

Spherical Roller Bearings

Tapered Roller Bearings

Thrust Bearings

Split Pillow Blocks

Super Precision Bearings

Linear Motion

Rolling Mill Bearings

Engineering Section

Guide Roll for Continuous Slab Caster

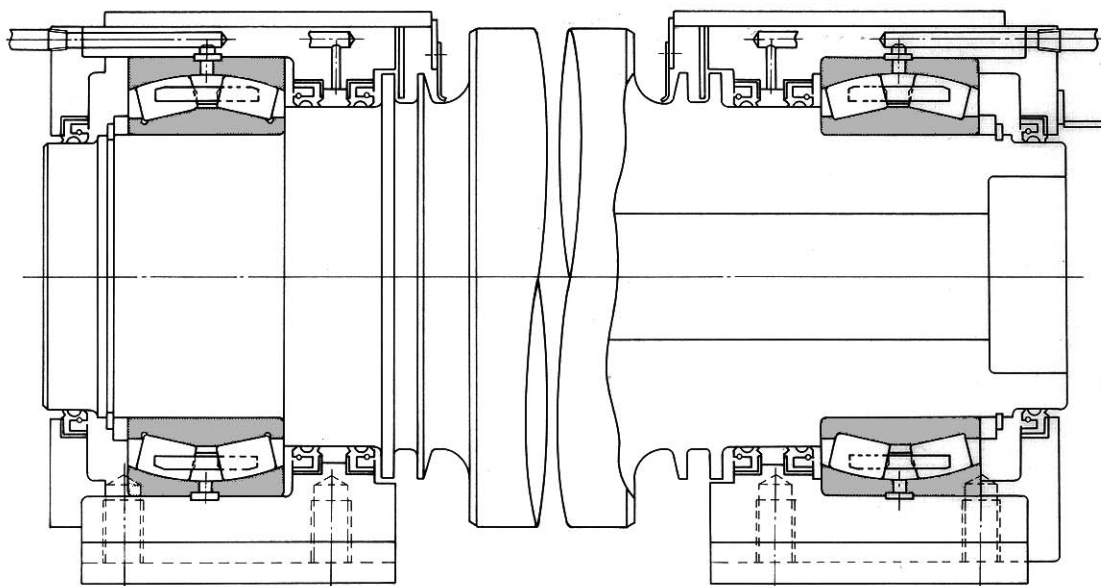

Spherical roller bearings are the most common bearing type used in continuous casting machines. Their excellent load carrying capacity and ability to handle misalignment due to shaft deflection makes them a natural for this application. The bearings are generally grease lubricated and usually have a loose fit between the bearing and both the shaft and housing.

Sealed-Clean Bearings for Guide Rolls and Pinch Rolls in Continuous Casters

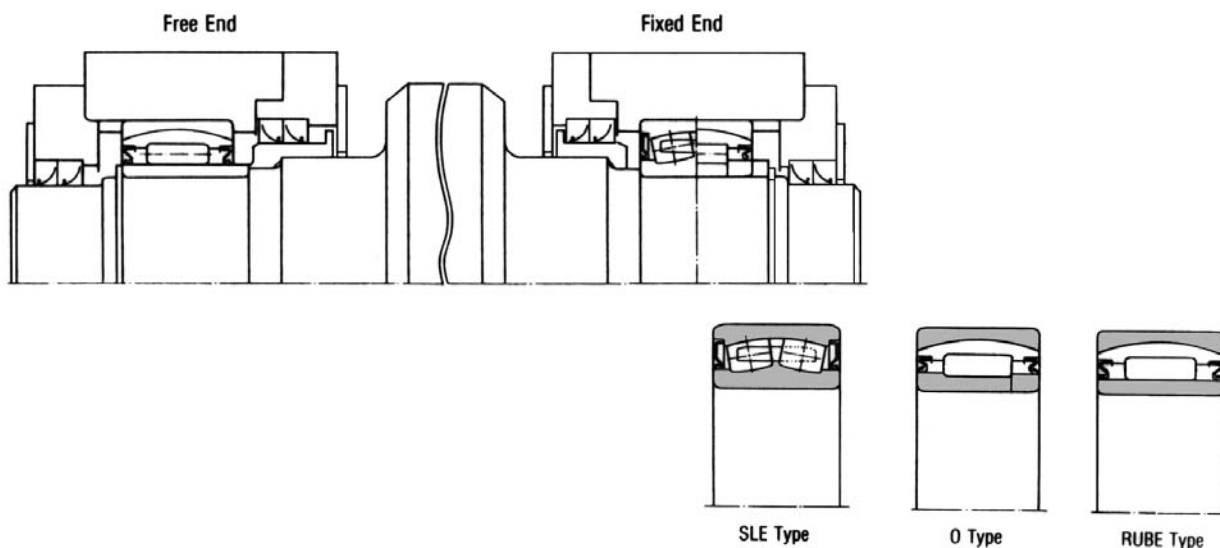

Sealed roller bearings provide extra protection against the water and scale common in continuous casting machines. These bearings are available in two basic types: cylindrical roller bearings with spherical alignment rings, RUBE type, and spherical roller bearings, SLE type. Either type can be supplied with a single seal, when replenishment of grease is desirable, or completely sealed and pre-packed with a high quality grease. Spherical roller bearings are recommended for fixed end positions while the self-aligning cylindrical roller bearings provide advantages for the float end position.

Work Roll Bearing Arrangement for Slabbing Mills

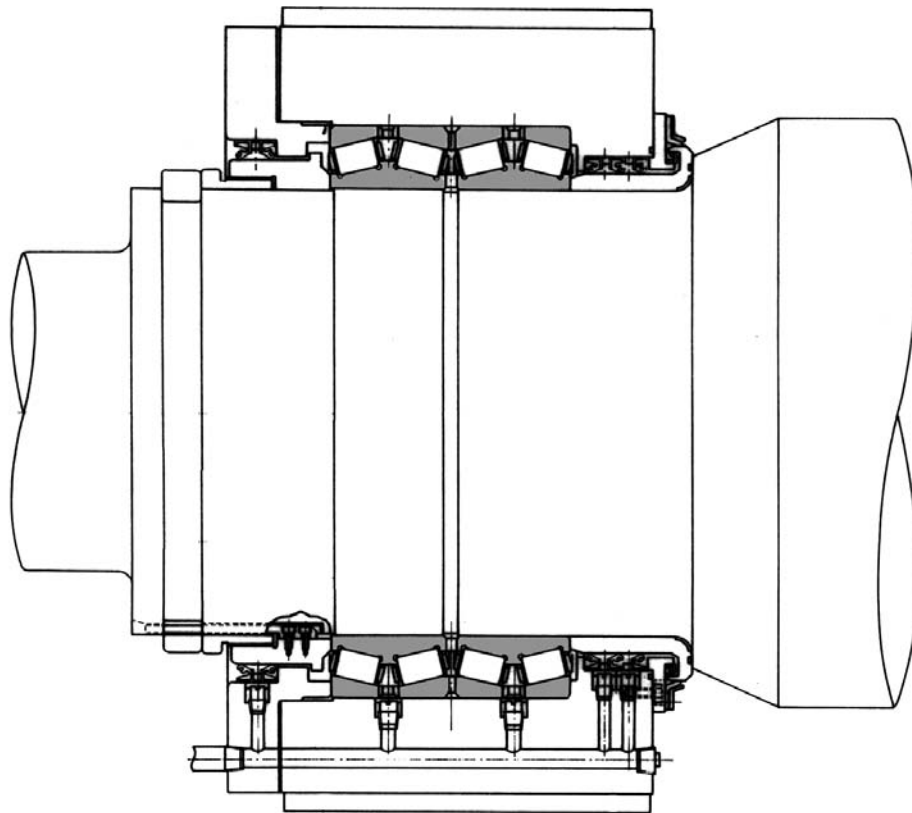

Large four-row tapered roller bearings, NSK KV type, are the most common bearings for work rolls in slabbing mills. Their ability to support high radial loads combined with axial loads make them a perfect choice. They have a loose fit with the roll and the housing and may be lubricated using grease, oil mist or oil-air systems.

Workroll Bearing Arrangement for Slabbing Mills or Universal Beam Mill

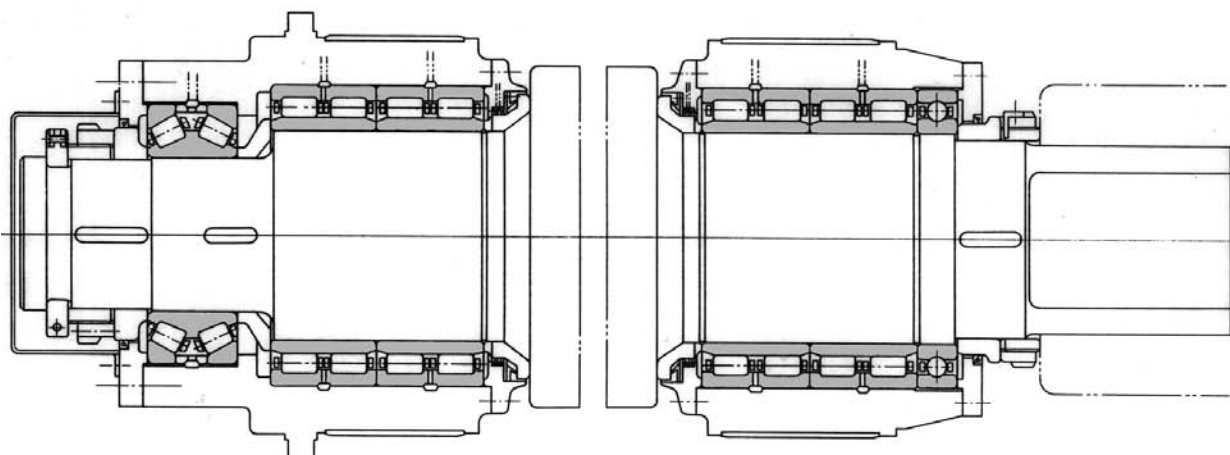

Because of the heavy loads, NSK RV type, four row cylindrical roller bearings are normally used. The bearing inner races are heat shrink fitted onto the rollneck and will remain with the rolls. The diameter under the rollers is held very precisely to insure that they can be used interchangeably with all inner rings. The inner races have NSK specially designed chamfers to assist in the easy installation of the chocks to the workrolls. The high axial forces are countered by a steep angle tapered roller thrust bearing, NSK KDH type. This is mounted in the operator side chock. A large diameter ball bearing, NSK 60xx or B type, is mounted in the drive side and unitizes the chock to the workroll.

Work Roll Bearing Arrangement for Four-High Plate Mill

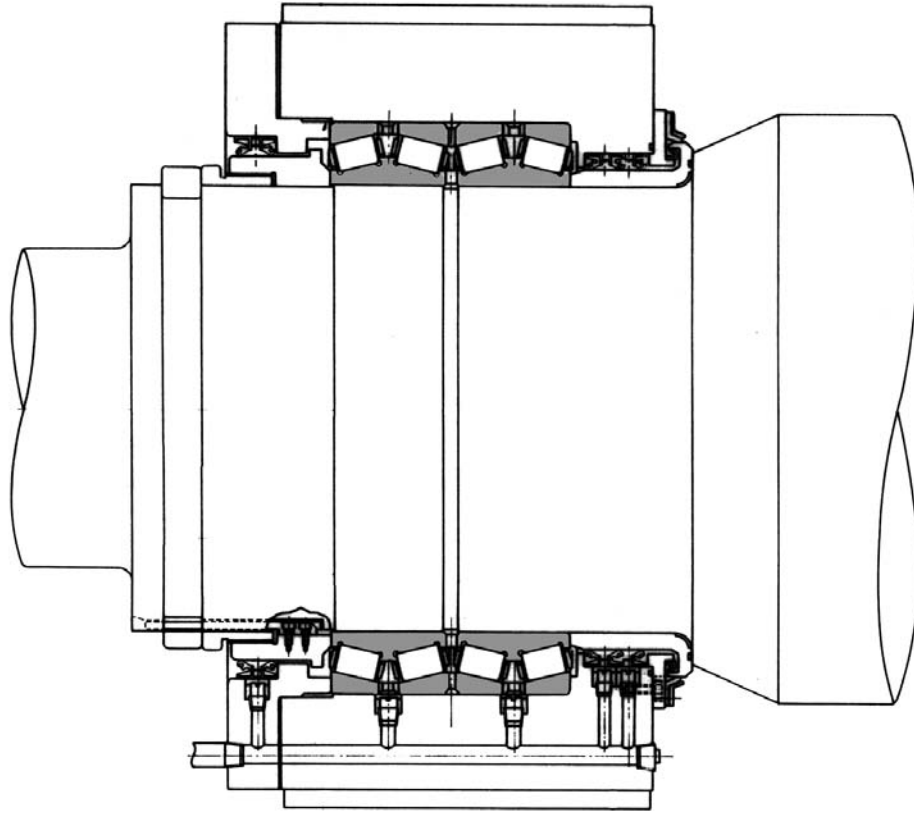

Large four-row tapered roller bearings, NSK KV type, are the most common bearings for work rolls in slabbery mills. Their ability to support high radial loads combined with axial loads make them a perfect choice. They have a loose fit with the roll and the housing and may be lubricated using grease, oil mist or oil-air systems.

Introduction

Ball Bearings

Cylindrical Roller Bearings

Spherical Roller Bearings

Tapered Roller Bearings

Thrust Bearings

Split Pillow Blocks

Super Precision Bearings

Linear Motion

Rolling Mill Bearings

Engineering Section

Vertical Edger Rolls for Roughing Section of Finishing Mill

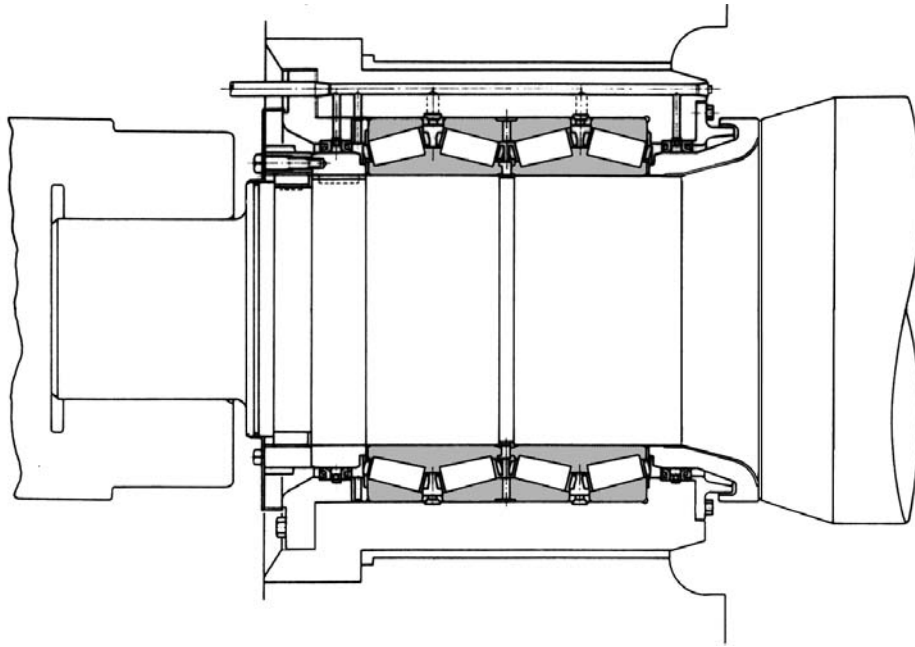

Bearings used in this application must have high radial and axial load carrying capacity. Therefore, NSK KV type, four roll tapered roller bearings and in some mills, NSK KH type, two roll tapered roller bearings are used. Special heavy duty roller retainer designs are used because of the high axial forces and misalignment. Low radial internal clearance insures that there is even load distribution across the bearing. Loose fits are used on both the inner and outer rings.

Introduction

Ball Bearings

Cylindrical Roller Bearings

Spherical Roller Bearings

Tapered Roller Bearings

Thrust Bearings

Split Pillow Blocks

Super Precision Bearings

Linear Motion

Rolling Mill Bearings

Engineering Section

Workroll Bearing Arrangement for Hot Strip, Roughing, and Finishing Mills

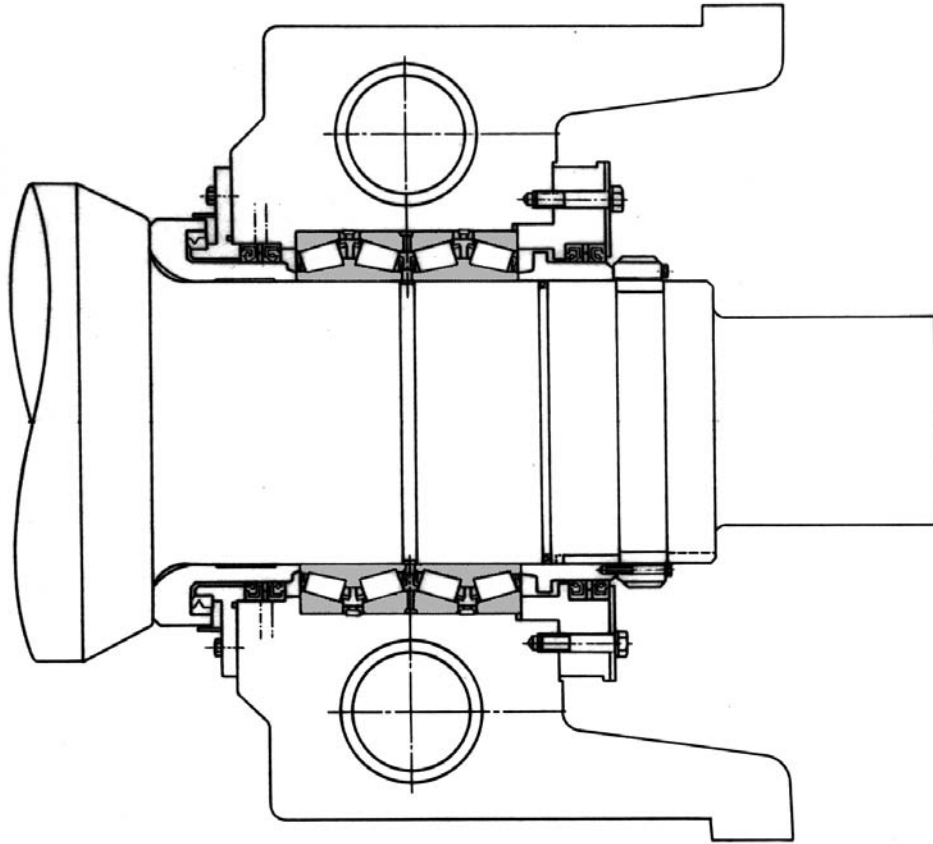

Workrolls in 4 high rolling mills use four row tapered roller bearings, NSK KV type. These bearings are slightly larger in size than those found in cold mills and also offers high capacity in both the radial and axial directions. The bearings are designed to be used with grease, oil mist, or oil-air system. Both the inner and outer rings are loose fitted.

Introduction

Ball Bearings

Cylindrical Roller Bearings

Spherical Roller Bearings

Tapered Roller Bearings

Thrust Bearings

Split Pillow Blocks

Super Precision Bearings

Linear Motion

Rolling Mill Bearings

Engineering Section

Sealed Clean Bearings for Hot Strip Mill Runout Tables

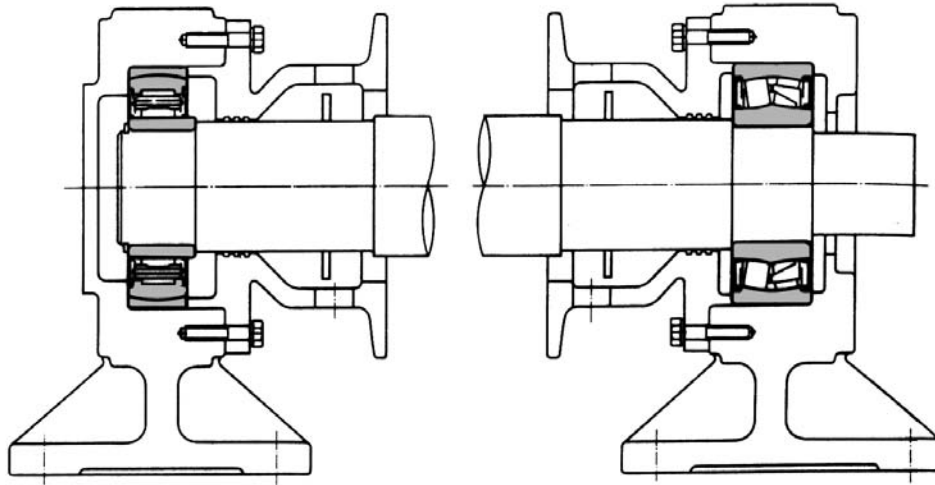

Spherical roller bearings, NSK SLE, and self-aligning cylindrical roller bearings, NSK RUBE types, are used on many runout tables. The spherical roller bearings fix the rolls and provide axial loading capability. Because of the large amount of thermal expansion of rolls, the cylindrical roller bearings allows for free movement. Expansion is taken between the inner ring and rollers eliminating the problems encountered when trying to take float in the housing. Bearings seals offer extra protection to the bearings when the typical mode of failure is contamination or inadequate lubrication.

Sealed Clean Workroll Bearing Arrangement for Cold Strip, Hot Strip, and Temper Mills

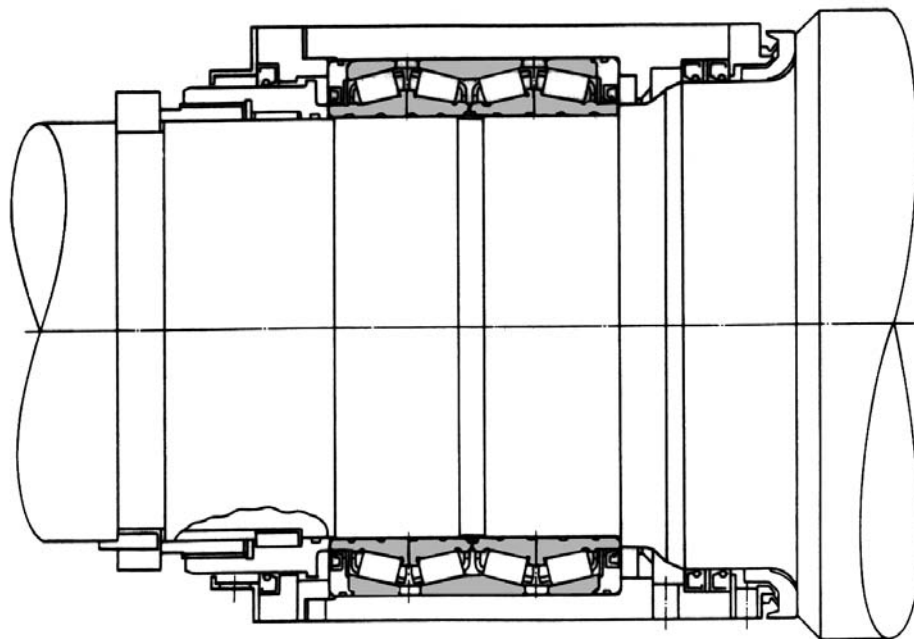

The NSK Sealed Clean Rollneck Bearings, KVE type, have replaced the conventional workroll bearings in many mills. Because they are sealed, they are better protected from rolling coolant and scale. Grease is packed in the bearings at installation and no further greasing is required for several months. This cuts operating costs substantially.

Workroll Bearing Arrangement for Cold Strip and Temper Mills

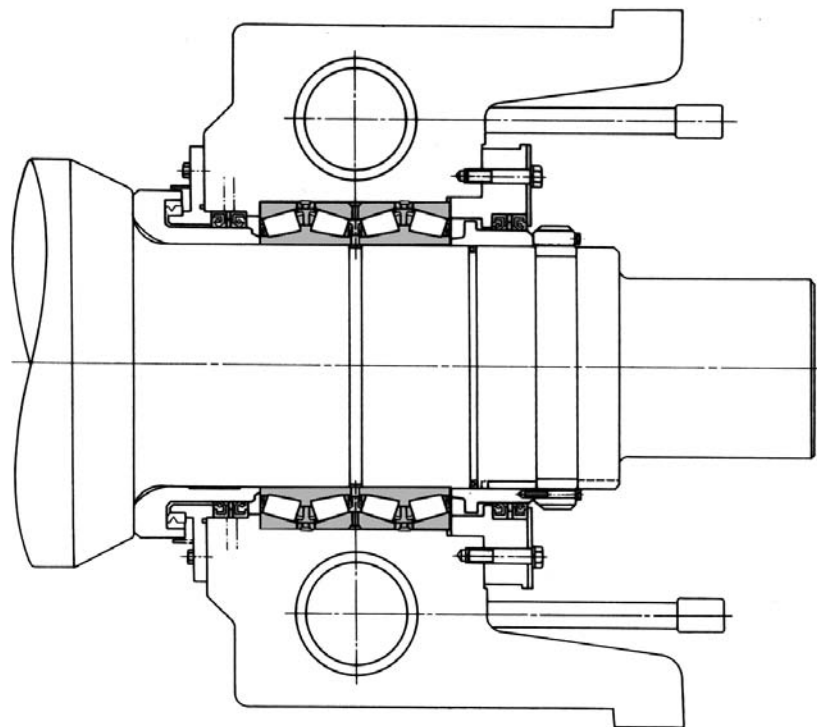

Most workrolls in a 4 high rolling mills use four row tapered roller bearings, NSK KV type. This bearing offers high capacity in both the radial and axial directions. The bearings are designed to be used with grease, oil mist, or oil-air system. Both the inner and outer rings are loose fitted. The intermediate roll of the modern 6 high mills also use this bearing.

Introduction

Ball Bearings

Cylindrical Roller Bearings

Spherical Roller Bearings

Tapered Roller Bearings

Thrust Bearings

Split Pillow Blocks

Super Precision Bearings

Linear Motion

Rolling Mill Bearings

Engineering Section

Back Up Roll for Strip Mills

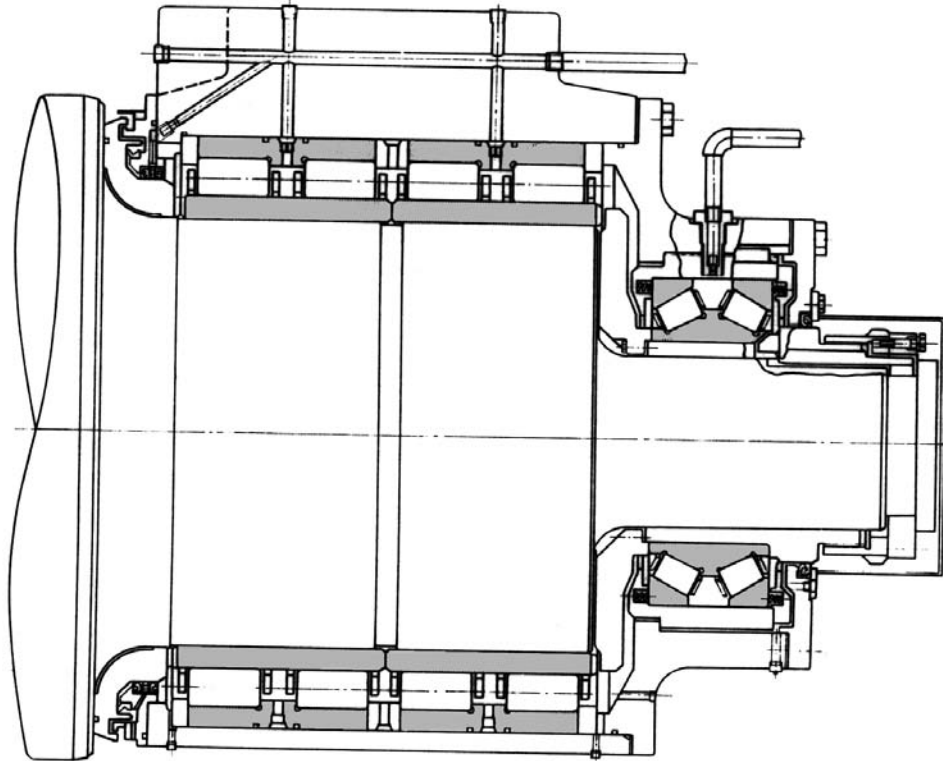

When high rolling accuracy is required, NSK RV type, four row cylindrical roller bearings are normally used. The bearings are supplied with better than normal running accuracies and controlled radial internal clearance. The inner rings are shrink mounted on the rollneck and the raceways are finish ground to further control the accuracy and clearance. The high axial forces are countered by a steep angle tapered roller thrust bearing, NSK KDH type, mounted in the operator side chock.

Screwdown Thrust Bearings for Strip Mills

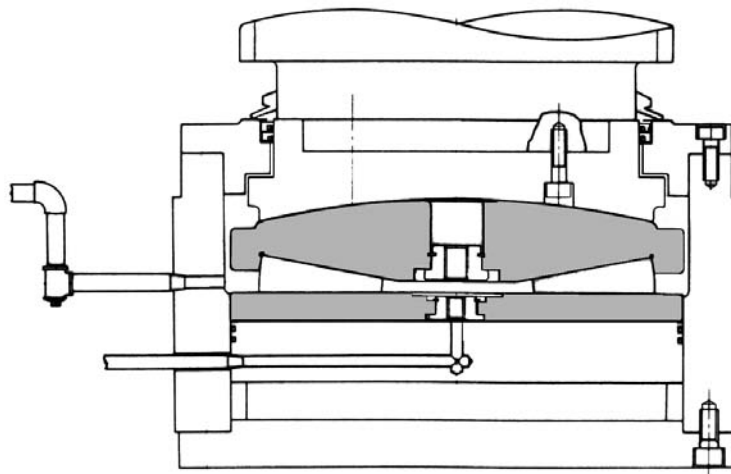

These high capacity tapered roller thrust bearings, NSK TFX type, sits on top of the top back up roll chock and is subjected to the hundreds of tons of rolling force. The spherical surface on the top race compensates for the misalignment created by the heavy load. Drip feed oil is used to lubricate these bearings.

Roll for Intermediate Stand of a Wire Mill

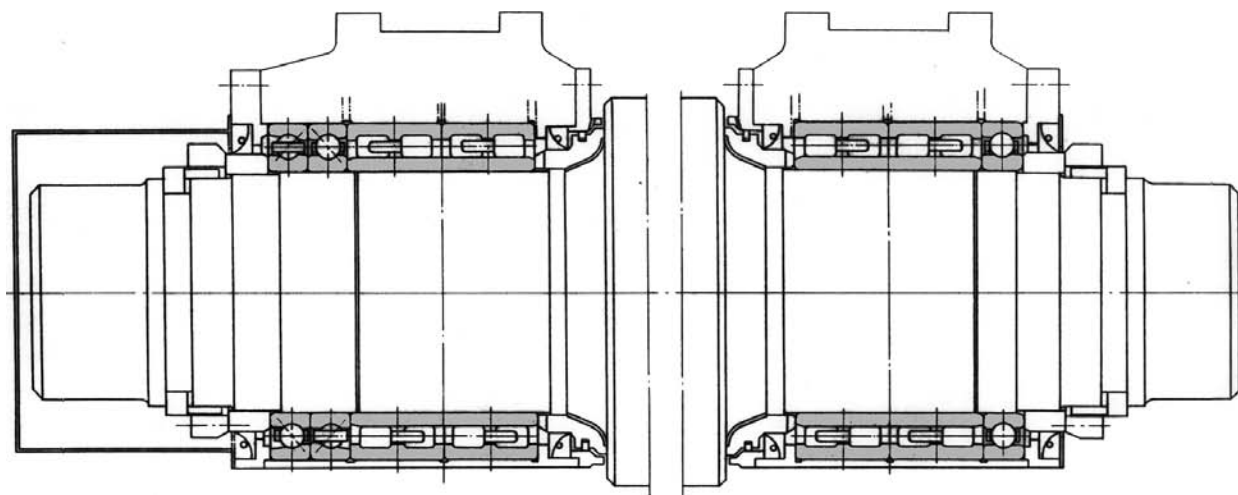

Four-row cylindrical roller bearings, **NSK RV** Type, provide an excellent combination of high load capacity, high speed capability and high running accuracy. The inner rings are tight fitted on the shaft and are interchangeable from one bearing to another. A pair of large angular contact ball bearings, **BAxxx** type, in the operator side chock support thrust loads while a single ball bearing maintains the axial relationship between the drive side chock and the roll.

Introduction

Ball Bearings

Cylindrical Roller Bearings

Spherical Roller Bearings

Tapered Roller Bearings

Thrust Bearings

Split Pillow Blocks

Super Precision Bearings

Linear Motion

Rolling Mill Bearings

Engineering Section

Back-up for a Four-High Reversing Hot Mill for Aluminum

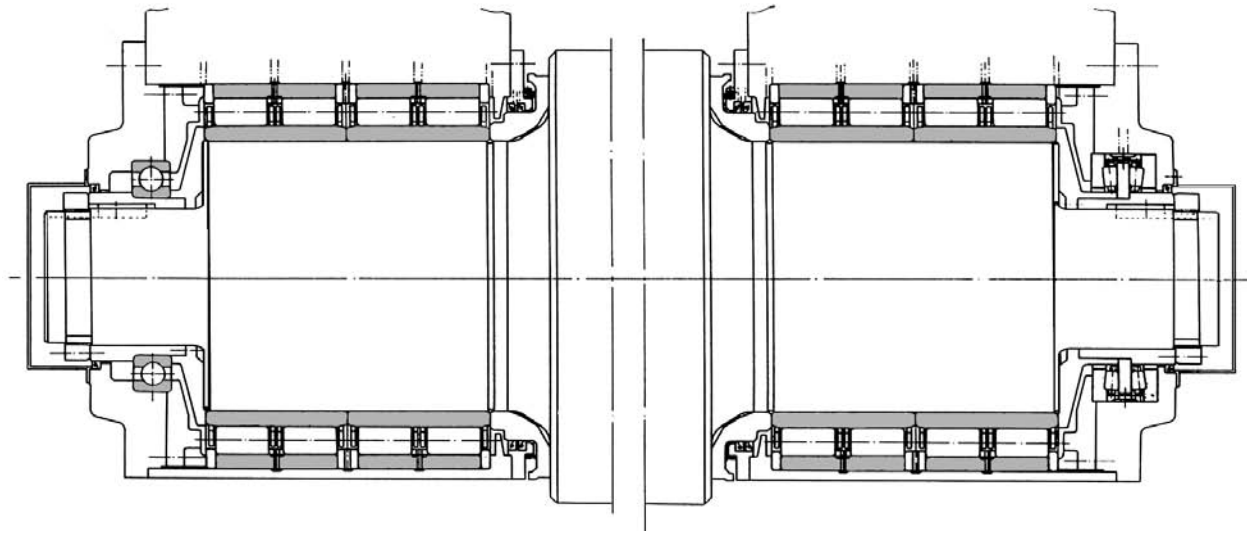

Four-row cylindrical roller bearings, **NSK RV** type, provide high load capacity necessary to support rolling loads while maintaining good accuracy. The inner rings are tight fitted to the rolls and are interchangeable from one bearing to another. A two-row tapered roller thrust bearing supports axial loads and a large ball bearing unitizes the drive side chock.

Introduction

Ball Bearings

Cylindrical Roller Bearings

Spherical Roller Bearings

Tapered Roller Bearings

Thrust Bearings

Split Pillow Blocks

Super Precision Bearings

Linear Motion

Rolling Mill Bearings

Engineering Section

Back-up Roll Assembly for Sendzimir-Type Cluster Mill

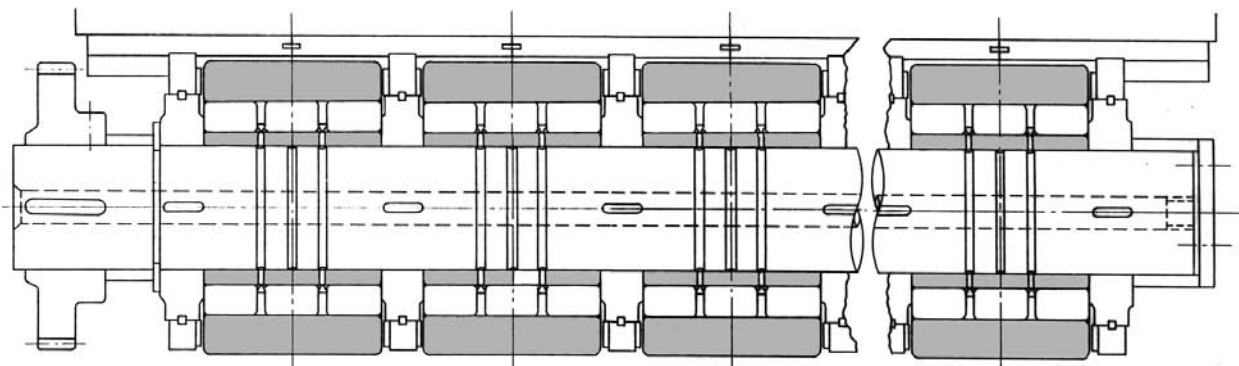

High running accuracy and careful matching of sets are an important feature for these bearings. The type of rolling element and the number of rows of rolling elements varies, but three rows of cylindrical rollers, NSK 3PLxxx type, is common. The inner rings are stationary on the shaft while the outer rings function as back-up rolls. Oil is supplied through the shaft to lubricate the bearings.

Introduction

Ball Bearings

Cylindrical Roller Bearings

Spherical Roller Bearings

Tapered Roller Bearings

Thrust Bearings

Split Pillow Blocks

Super Precision Bearings

Linear Motion

Rolling Mill Bearings

Engineering Section

Roll Unit Bearings for Tension Levelers

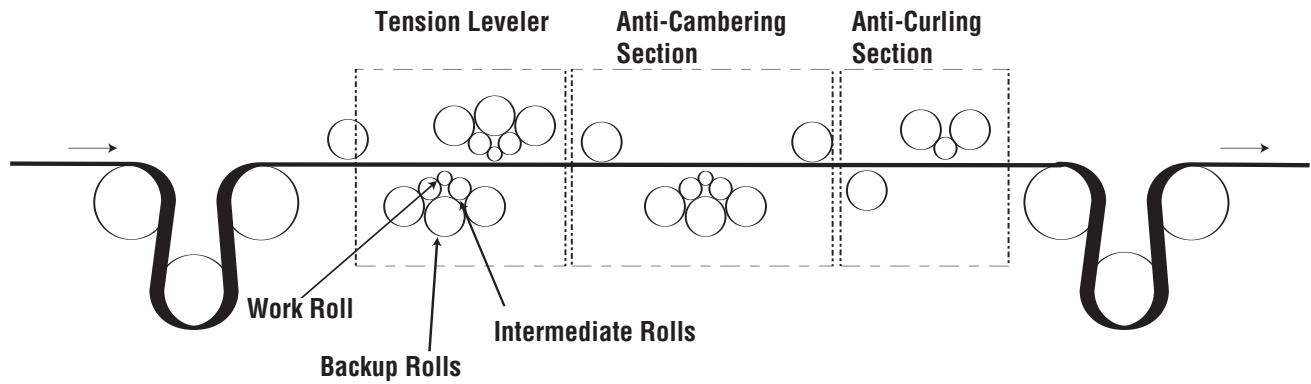

NSK tension leveler roll unit bearings, type UMB, combine high accuracy, low torque and excellent sealing in a variety of maintenance-free units.

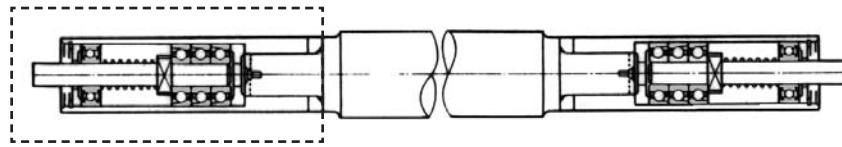

Thrust Blocks for Work Rolls and Intermediate Rolls – An assembly using angular contact ball bearings provides high thrust capacity and an ability to accelerate instantly. Low torque grease and seals provide reliable, maintenance-free operation.

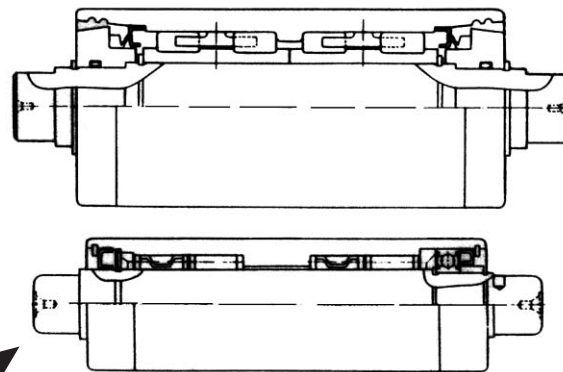

Backup Roll Units – Backup rolls offer high radial load capacity and are matched in sets to assure even support by all rolls. Optional special materials extend roll surface life in wet applications. Life of the assembly can be extended by using NSK regrind service.

Table of Contents Engineering Section

Introduction
Ball Bearings
Cylindrical Roller Bearings
Spherical Roller Bearings
Tapered Roller Bearings
Thrust Bearings
Split Pillow Blocks
Super Precision Bearings
Linear Motion
Rolling Mill Bearings
Engineering Section

ROLLING BEARINGS

Design and Classification299
Description and Features300

BEARING SELECTION

Selection Based on Basic Load Rating ..303
Equivalent Bearing Loads304
Correction of Basic Load Due to Temp. ..304
Adjustments to Fatigue Life Rating305
Static Load Rating305
Selection Based On Dimensions305

BEARING IDENTIFICATION

Bearing Number Formulation306
Snap Ring and Groove Dimensions310

BEARING TOLERANCES

Bearing Tolerance Standards312
Bearing Tolerance Nomenclature313
Tolerances for Radial Bearings
(except Tapered)314
Tolerances for Metric Tapered Bearings .318
Tolerances for Inch Tapered Bearings ..322
Tolerances for Thrust Ball Bearings324
Tolerances for Thrust Spherical Bearings .326

BEARING FITS AND INTERNAL CLEARANCE

Fit-Why It's Important327
How to Select Proper Fit328
Bearing Internal Clearance330
Internal Clearance Tables330
Selection of Bearing Internal Clearance .333
Changes in Radial Internal Clearance ...334

PRELOADED BEARINGS

Why Preload?335
How to Preload Duplex Bearings335
Selecting Preloading Method336
Preload Tables337

BEARING LUBRICATION

Lubrication-The Purpose338
Selecting the Correct Methods338
Grease Lubrication338
Oil Lubrication339
Lubricants342

Bearing Installation, Maintenance and Inspection

How to Handle Bearings345
Mounting-Factors to Consider345
Inspecting and Trouble-shooting349
How to Dismount Bearings351
Cleaning, Inspection, and Evaluation ...353
Maintenance and Inspection353

APPENDICES

Shaft Diameter Tolerances356
Housing Tolerances358
Part Number Index360
Conversion Factors366

Rolling Bearings – Types and Features

Design and Classification

Rolling bearings use balls or other rolling elements, located between bearing rings, to minimize friction. The rolling elements are separated and held in position by "cages" or other retaining devices.

The construction of six of the most common rolling element bearings are illustrated here for identification of nomenclature. Specific dimensions and details for these bearings are given in the dimensional tables in the preceding sections of this catalog.

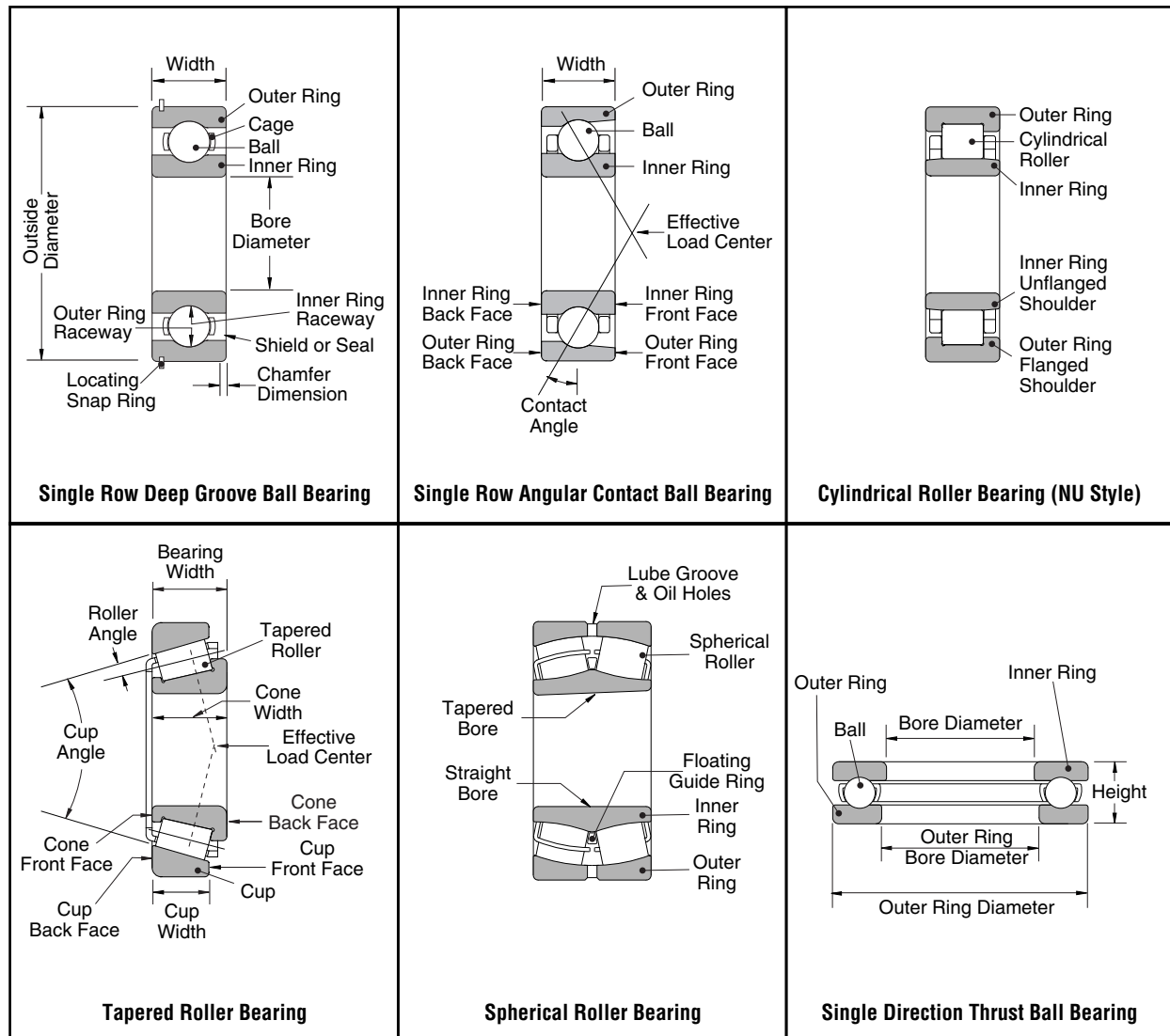

Figure 10.1 — Nomenclature for Bearing Components and Reference Dimensions.

Introduction

Ball Bearings

Cylindrical Roller Bearings

Spherical Roller Bearings

Tapered Roller Bearings

Thrust Bearings

Split Pillow Blocks

Super Precision Bearings

Linear Motion

Rolling Mill Bearings

Engineering Section

In comparison to plain or sleeve type bearings, rolling bearings offer several advantages:

- Starting torque is minimal and the difference between starting torque and running torque is small.
- Rolling bearings can be designed to take both radial and axial loads simultaneously or independently.
- Rolling bearings can be preloaded to produce a negative clearance. This gives the bearing greater rigidity to constrain the radial and axial movement of a shaft relative to its housing.

Depending on the shape of their rolling elements, bearings fall into two main classes--ball bearings and roller bearings. Roller bearings are further classified by the specific shape of their rollers and by other individual features.

Bearings are also classified by function. For example, they can be classified as "radial," "thrust" or both, depending on the direction of the applied load and may be further classified as cylindrical, tapered, spherical or duplex depending on their configuration.

Description and Features

Typical bearing configurations are described below:

Deep Groove Ball Bearings are the most common type of rolling element bearing. They have a single row of balls held in place by a cage, usually made of steel, that rotates between two rings with polished raceways. The design of the bearing allows for radial and axial loading while operating at high speeds. These bearings often come with shields or seals to protect the inside of the bearing from contamination in the application.



Double Row Ball Bearings have two rows of balls between two bearing rings. This is a back-to-back mounting of two single-row angular contact ball bearings, but their inner and outer rings are each integrated into one. This design allows for heavier axial loads in either direction and a significant radial load capacity. Some of these bearings are also available with shields and seals.



Self-Aligning Ball Bearings have an inner ring with two raceways. The outer ring has one spherical raceway and its center coincides with that of the bearing. Because of this, the axis of the inner ring, the balls and the cage can deflect around the bearing center. As a result, minor angular misalignment of the shaft, in relation to the bearing housing, can be accommodated. This type of bearing, with tapered bore, is often mounted using an adapter sleeve.



Cylindrical Roller Bearings have large radial load capacities. The rolling elements remain in linear contact with the bearing raceway and are precisely crowned to relieve the edge loading caused by shaft misalignment.



A cylindrical roller bearing in which either the inner or outer ring has no rib, may be used as free-end or floating bearing because its rings are free to move, in an axial direction, relative to each other. If either the inner or outer ring has two ribs and the other ring has one rib, the bearing is capable of taking a certain amount of axial load in one direction. Double row cylindrical roller bearings have high radial rigidity and are used primarily for precision machine tools.

Tapered Roller Bearings can take both radial and axial loads in one direction. They use conical rolling elements which are guided by ribs on the bearing's inner ring. The bearing rollers are precisely crowned near each end to relieve edge loading.



Since an axial force is generated in these bearings when a radial load is applied, they are often mounted in pairs, face to face, like single row angular contact ball bearings. When this is the case, the proper internal clearance can be obtained by adjusting the axial distance between the inner rings or outer rings of the two opposed bearings. Since they are separable, the inner and outer rings can be mounted independently.

Tapered roller bearings are divided into three types--normal, medium angle and steep angle--depending on the degree of contact angle. Double row tapered roller bearings are also available.

Spherical Roller Bearings are capable of handling both radial and axial loads in either direction and have excellent radial load carrying capacity. The line of contact between the barrel-shaped rollers and the outer ring raceway is a circular arc centered on the bearing axis. The outer ring raceway is spherical, making it self-aligning. There are two inner raceways and two rows of rollers.



Spherical roller bearings with tapered bores can be mounted directly on tapered shafts or on cylindrical shafts by using an adapter or withdrawal sleeve. Spherical roller bearings are available with pressed-steel, machined bronze or molded cages.

Duplex Bearing Set is a pair of radial bearings combined in various arrangements. It is often a combination of angular contact ball bearings or of tapered roller bearings. It may be a combination placed face to face (type DF) or back to back (type DB) or in tandem (type DT). Types DF and DB are capable of taking radial loads and axial loads in either direction. They may be modified to accommodate a variety of preloading requirements. Type DT is used when the application requires large axial loads in one direction.



Single Direction and Double Direction Thrust Ball Bearings are composed of washer-like bearing rings with raceway grooves for the balls. The ring attached to the shaft is called the inner ring or tight washer and the ring attached to the housing is called the outer ring or loose washer. In double direction thrust ball bearings there are three rings, with the center one fixed to the shaft.



Single direction thrust ball bearings can support axial loads in one direction; double direction, in two. There are also thrust ball bearings with an aligning seat washer beneath the outer ring to compensate for shaft misalignment or mounting errors.

Spherical Roller Thrust Bearings have a spherical raceway in the outer ring with the rollers obliquely arranged in a single row. Since the raceway in the outer ring is spherical, these bearings are self-aligning.



Spherical roller thrust bearings have a very high axial load capacity and are capable of taking moderate radial loads when an axial load is imposed. These bearings are suited for lower speeds and require oil for lubrication. They are assembled with pressed-steel cages or machined brass cages.

Introduction

Ball Bearings

Cylindrical Roller Bearings

Spherical Roller Bearings

Tapered Roller Bearings

Thrust Bearings

Split Pillow Blocks

Super Precision Bearings

Linear Motion

Rolling Mill Bearings

Engineering Section

Bearing Selection

The original equipment manufacturer (OEM) will select a bearing for their equipment based on the loading requirements of, and the space available for, the bearing. The bearing style and size provide the foundation for the bearing selection based on the load carrying capacity in relation to the loads to be carried.

Selection Based on Basic Load Rating

The most common way to determine bearing life is by using the load ratings of the bearing and the loads required by the application. The common measurement is “**L₁₀**” life, defined as the number of revolutions before metal fatigue first appears on 10% of a large group of like bearings. This is referred to as basic rating life or fatigue life. The equations for calculating **L₁₀** life are:

$$\text{For ball bearings: } L_{10} = \left(\frac{C}{P}\right)^3 \quad \text{For roller bearings: } L_{10} = \left(\frac{C}{P}\right)^{10/3}$$

Where **L₁₀**: Rating fatigue life (1 million Revs)

P: Bearing Equivalent Load (lbf, N, kgf), see below for calculation of **P**

C: Basic Load Rating (from catalog tables)

For radial bearings, **C=C_r** For thrust bearings, **C=C_a**

If the bearings run at a constant speed, it is convenient to determine **L₁₀** life in terms of hours. This equation is expressed as

$$\text{For ball bearings: } L_{10h} = \frac{1,000,000}{60n} \left(\frac{C}{P}\right)^3 \quad \text{For roller bearings: } L_{10h} = \frac{1,000,000}{60n} \left(\frac{C}{P}\right)^{10/3}$$

Where **L_{10h}**: Rating fatigue life in hours **n**: Rotational speed, RPM

Equivalent Bearing Loads (P)

To determine the value of **P**, you must first determine the effects of the radial and axial loads applied. Once this hypothetical load is determined, it is assumed to be constant in magnitude and direction. The general formula for the calculation of **P** is: $P = X Fr + Y Fa$

Where **P**: Bearing equivalent load (lbf, N, kgf)

X: the Radial factor

Fr: the Actual constant radial load

Y: the Axial factor

Fa: the Actual constant axial load

The values for **X** and **Y** can be determined using the tables 10.2-10.4. First, determine the type of bearing being considered. Then, calculate the ratio of the axial load to the radial load and compare this to the bearings “**e**” value in the table.* The “**e**” value is determined by multiplying the axial load applied to the bearing by the bearing coefficient factor, **f₀**, which is obtained from the bearing tables. Divide the result by the static radial load rating. Locate the result in the first column and read across to find the “**e**” value. (In the case of angular contact bearings, the “**i**” value must be used. If a duplex pair in a DB or DF configuration is used, the “**i**” value is 2.) In effect, if the axial load is small compared to the radial load, then only the radial load is considered. If not, then a combination of the two is used. After determining the equivalent bearing load, **P**, the **L₁₀** formula given above can be used to determine the **L₁₀** life with 90% reliability for a given bearing’s basic load rating. Also, for a required **L₁₀** life, a basic load rating requirement can be found for bearing selection.

Table 10.2 — Equivalent Load Factors for Ball Bearings

Dynamic Equivalent Load $P=XFr+YFa$					
$\frac{f_o F_a}{C_{or}}$	e	$\frac{F_a}{F_r} \leq e$		$\frac{F_a}{F_r} > e$	
		X	Y	X	Y
0.172	0.19	1	0	0.56	2.30
0.345	0.22	1	0	0.56	1.99
0.689	0.26	1	0	0.56	1.71
1.03	0.28	1	0	0.56	1.55
1.38	0.30	1	0	0.56	1.45
2.07	0.34	1	0	0.56	1.31
3.45	0.38	1	0	0.56	1.15
5.17	0.42	1	0	0.56	1.04
6.89	0.44	1	0	0.56	1.00

Static Equivalent Load

$$\frac{F_a}{F_r} > 0.8, P_o = 0.6F_r + 0.5F_a$$

$$\frac{F_a}{F_r} \leq 0.8, P_o = F_r$$

Table 10.3 — Equivalent Load Factors for Angular Contact Ball Bearings

Dynamic Equivalent Load $P=XFr+YFa$										
Contact Angle	$\frac{if_o F_a^*}{C_{or}}$	e	Single, DT				DB or DF			
			$F_d/F_r \leq e$		$F_d/F_r > e$		$F_d/F_r \leq e$		$F_d/F_r > e$	
			X	Y	X	Y	X	Y	X	Y
15°	0.178	0.38	1	0	0.44	1.47	1	1.65	0.72	2.39
	0.357	0.40	1	0	0.44	1.40	1	1.57	0.72	2.28
	0.714	0.43	1	0	0.44	1.30	1	1.46	0.72	2.11
	1.07	0.46	1	0	0.44	1.23	1	1.38	0.72	2.00
	1.43	0.47	1	0	0.44	1.19	1	1.34	0.72	1.93
	2.14	0.50	1	0	0.44	1.12	1	1.26	0.72	1.82
	3.57	0.55	1	0	0.44	1.02	1	1.14	0.72	1.66
	5.35	0.56	1	0	0.44	1.00	1	1.12	0.72	1.63
25°	--	0.68	1	0	0.41	0.87	1	0.92	0.67	1.41
30°	--	0.80	1	0	0.39	0.76	1	0.78	0.63	1.24
40°	--	1.14	1	0	0.35	0.57	1	0.55	0.57	0.93

*For i , use 2 for DB, DF and 1 for DT.

Static Equivalent Load $P_o = X_o F_r + Y_o F_a$

Contact Angle	Single, DT		DB or DF	
	X_o	Y_o	X_o	Y_o
15°	0.5	0.46	1	0.92
25°	0.5	0.38	1	0.76
30°	0.5	0.33	1	0.66
40°	0.5	0.26	1	0.52

Single or DT mounting
When $F_r > 0.5F_r + Y_o F_a$
use $P_o = F_r$

Table 10.4 — Load Conversion Factors for Other Bearings

CYLINDRICAL ROLLER SPHERICAL ROLLER TAPERED ROLLER SELF-ALIGNING BALL	PLEASE CONSULT NSK ENGINEERING FOR VALUES, OR REFER TO NSK CATALOG E1101a
--	---

Correction of Basic Load Rating Due to Temperature

The operating temperature will significantly affect the fatigue life by altering the hardness of the bearing. Consequently, the basic load rating, which depends on the physical properties of the bearing material, will decrease with higher temperatures. Thus, the basic load rating must be corrected for higher temperatures using the equation: $C_t = f_t \cdot C$

Where C_t : Basic load rating after temperature correction

f_t : Temperature factor (see following table)

C : Basic load rating from tables, before application of temperature correction.

Table 10.5 — Temperature Factor (f_t)

	Bearing Temperature (°C)			
	≤150	175°	200°	250°
Temperature Factor f_t	1.00	.95	.90	.75

Adjustments to Fatigue Life Rating

Each style of bearing has many characteristics that make that bearing better suited for an application than another bearing. For example, some common applications require a bearing that can handle misalignment, loads in both directions, high speeds, etc..., or a combination of two or more. These operating conditions will alter the bearing life and are accounted for by using correction factors for temperature, reliability, bearing material, and other operating conditions. For the complete list of adjustment factors and their values, please contact NSK engineering or refer to NSK catalog E1101a.

The formula for adjusting life based on reliability, material, and operating conditions is:

$$L_{na} = a_1 * a_2 * a_3 * L_{10}$$

Where L_{na} : Adjusted life rating.

L_{10} : Life rating, adjusted for fatigue life for 90% reliability. This may not satisfy all applications. For higher reliability requirements, L_{10} must be adjusted.

a_1 : Life correction factor for reliability. This is determined from the reliability required of the bearing for its application (see table below).

a_2 : Life correction factor for bearing material.

a_3 : Life correction factor for operating conditions

Values of a_2 and a_3 are difficult to determine, however, for most applications, $a_2 * a_3 = 1$ can be assumed. If you have concerns about lubrication viscosity, temperature, contamination, misalignment, or other operating abnormalities, please consult NSK Engineering.

Table 10.6 — Reliability Factor (a_1).

	Reliability					
	90%	95%	96%	97%	98%	99%
a_1	1.00	.62	.53	.44	.33	.21

Static Load Rating

Some applications are stationary with loads for long periods, rotate at very low speeds, are subjected to slow oscillations, or are exposed to shock loads. In these events, the static load rating (C_{0r} or C_{0a}) must be used in the life calculations. Please contact NSK engineering for more details.

Selection Based on Dimensions

For single row bearings having the same width series, diameter series, and bore size, all styles have the same bore, O.D., and width. For example, 6203, NJ203, and 7203 all have a 17mm bore, a 42mm O.D., and 12mm width. Therefore, selection can be made based on the requirements of the application such as, speeds, misalignment capabilities, bearing value, etc..., provided that the life requirement is met by the bearing style.

Bearing Identification

Bearing Number Formulation

Bearings are identified by numbers and letters which designate bearing type, boundary dimensions, tolerance class, internal clearance and other specifications. The numbers used for standard bearings conform to ISO 15, Designation of Rolling Bearings. Boundary dimensions for the most commonly used bearings are based on the ISO Boundary Dimensions Tables.

In order to establish certain standards in addition to those specified in ISO, NSK also uses various symbols of its own.

Table 10.7 — Bearing Series Numbers	Bearing Series	Bearing Type	Dimension Series	
			Width [†] Series	Diameter Series
Single Row Deep Groove Ball Bearing	68	6	(1)	8
	69	6	(1)	9
	60	6	(1)	0
	62	6	(0)	2
	63	6	(0)	3
	64	6	(0)	4
Single Row Angular Contact Ball Bearing	70	7	(1)	0
	72	7	(0)	2
	73	7	(0)	3
	74	7	(0)	4
Self-Aligning Ball Bearing	12	1	(0)	2
	13	1	(0)	3
	22	2	(2)	2
	23	2	(2)	3
Single Row Cylindrical Roller Bearing	NU10	NU	1	0
	NU2	NU	(0)	2
	NU22	NU	2	2
	NU3	NU	(0)	3
	NU23	NU	2	3
	NU4	NU	(0)	4
	NJ2	NJ	(0)	2
	NJ22	NJ	2	2
	NJ3	NJ	(0)	3
	NJ23	NJ	2	3
	NJ4	NJ	(0)	4
	N2	N	(0)	2
	N3	N	(0)	3
	N4	N	(0)	4
NF2	NF	(0)	2	
NF3	NF	(0)	3	
NF4	NF	(0)	4	
Double Row Cylindrical Roller Bearing	NNU49	NNU	4	9
	NN30	NN	2	0
Metric Tapered Roller Bearing	320	3	2	0
	302	3	0	2
	322	3	2	2
	303	3	0	3
	323	3	2	3
Spherical Roller Bearing	230	2	3	0
	231	2	3	1
	222	2	2	2
	232	2	3	2
	213 ^{††}	2	0	3
	223	2	2	3
Thrust Ball Bearing with Flat Seat	511	5	1	1
	512	5	1	2
	513	5	1	3
	514	5	1	4
	522	5	2	2
	523	5	2	3
	524	5	2	4
Spherical Roller Thrust Bearing	292	2	9	2
	293	2	9	3
	294	2	9	4

[†] The width series numbers shown in parentheses are usually omitted.

^{††} 213 is customary usage since this series would be 203 according to standard practice

Introduction
Ball Bearings
Cylindrical Roller Bearings
Spherical Roller Bearings
Tapered Roller Bearings
Thrust Bearings
Split Pillow Blocks
Super Precision Bearings
Linear Motion
Rolling Mill Bearings
Engineering Section

Bearing Number Formulation (Continued)

Bearing series numbers indicate bearing types and dimension series. They constitute the basic number structure for bearing designations. These are shown in Table 10.7 on page 306. Supplementary symbols and meanings of typical numbers and symbols are shown in Table 10.8 on page 308.

Typical examples of bearing designations are illustrated below:

6 3 08 ZZ C3
 | | | | |
 | | | | | Radial clearance (C3)
 | | | | | Shields on Both Sides
 | | | | | Bearing Bore (40mm)
 | | | | | Diameter Series 3
 Single Row Deep Groove Ball Bearing

7 2 20 A DB C3
 | | | | | | |
 | | | | | | | Axial Clearance (C3)
 | | | | | | | Back-to-Back Arrangement
 | | | | | | | Contact Angle (30°)
 | | | | | | | Bearing Bore (100mm)
 | | | | | | | Diameter Series 2
 Single Row Angular Contact Ball Bearing

1 2 06 K + H206
 | | | | | | |
 | | | | | | | Adapter with 25mm Bore
 | | | | | | | Tapered Bore (1:12 Taper)
 | | | | | | | Bearing Bore (30mm)
 | | | | | | | Diameter Series 2
 Self-Aligning Ball Bearing

HR 3 0 2 07 J
 | | | | | | |
 | | | | | | | Small Diameter of Outer Ring Raceway
 | | | | | | | and Contact Angle Conform to ISO
 | | | | | | | Standard
 | | | | | | | Bearing Bore (35mm)
 | | | | | | | Diameter Series 2
 | | | | | | | Width Series 0
 Tapered Roller Bearing
 High Capacity Bearing

NU 3 18 M ()
 | | | | | | |
 | | | | | | | Radial Clearance (Blank is CN)
 | | | | | | | Machined Brass Cage
 | | | | | | | Bearing Bore (90mm)
 | | | | | | | Diameter Series 3
 Cylindrical Roller Bearing (NU Type)

2 4 0 /1000 M K30 E4 C3
 | | | | | | | | | | | | |
 | | | | | | | | | | | | | Radial Clearance (C3)
 | | | | | | | | | | | | | Outer Ring with Oil Groove
 | | | | | | | | | | | | | and Oil Holes
 | | | | | | | | | | | | | Tapered Bore (1:30 Taper)
 | | | | | | | | | | | | | Machined Brass Cage
 | | | | | | | | | | | | | Bearing Bore (1,000mm)
 | | | | | | | | | | | | | Diameter Series 0
 | | | | | | | | | | | | | Width Series 4
 Spherical Roller Bearing

NN 3 0 17 K CC1 P4
 | | | | | | | | | | | | |
 | | | | | | | | | | | | | Tolerance to ISO Class 4
 | | | | | | | | | | | | | Radial Clearance for Matched
 | | | | | | | | | | | | | Cylindrical Roller Bearings
 | | | | | | | | | | | | | Tapered Bore (1:12 Taper)
 | | | | | | | | | | | | | Bearing Bore (85mm)
 | | | | | | | | | | | | | Diameter Series 0
 | | | | | | | | | | | | | Width Series 3
 Cylindrical Roller Bearing (NN Type)

5 1 2 15
 | | | | |
 | | | | | Bearing Bore (75mm)
 | | | | | Diameter Series 2
 | | | | | Height Series 1
 Thrust Ball Bearing

Table 10.8 — Formulation of Bearing Numbers

Basic Bearing		Bore		Bearing Series	
Bearing Series				68	Single Row Deep Groove Ball Bearings
Bore				69	Single Row Angular Contact Ball Bearings
Contact Angle		1 thru 9	Bore in mm	60	
Internal Design		00	10mm	:	
Material		01	12mm	70	
Cage		02	15mm	72	Single Row Angular Contact Ball Bearings
External Seals, Shields		03	17mm	73	
		/22	22mm	:	
		/28	28mm	12	
		/32	32mm	13	Self-Aligning Ball Bearings
		04 thru 96	Multiply by 5 for Bore in mm (ex. 04=20mm)	22	
		/500 thru /2500	Bore in mm	:	
				NJ 2	
				N 3	Cylindrical Roller Bearings
				NN 30	
				:	
				320	Tapered Roller Bearings
				322	
				323	
				:	
				230	Spherical Roller Bearings
				222	
				223	
				:	
				511	Thrust Ball Bearings with Flat Seats
				512	
				513	
				:	
				292	Spherical Roller Thrust Bearings
				293	
				294	
				:	

Internal Design		Material		Cage	
A	Modified Internal Design	g	Case-Hardened Steel Used in Outer Rings, Inner Rings and Rolling Elements	M	Machined Brass Cages
J	Small Diameter of Outer Ring Raceway and Contact Angle of Tapered Roller Bearings Conform to ISO	h	Stainless Steel Used in Outer Rings, Inner Rings and Rolling Elements	W	Pressed Steel Cages
CA	(For High Capacity Bearings) Spherical Roller Bearings with Machined Cages			T	Phenolic Resin/Polyamide Cages
CD	Spherical Roller Bearings with Pressed Cages			V	Bearings without Cages (Cageless Ball and Roller Bearings)
E	Cylindrical Roller Bearings			H	(Spherical Bearings) Polyamide Cages
H	Spherical Radial and Thrust Roller Bearings				
HR	Tapered Roller Bearings				

Contact Angle Angular Contact Ball Bearings		Contact Angle Tapered Roller Bearings	
A	30°	(none)	Contact Angle Less than 17°
B	40°	C	Contact Angle Approx. 20°
C	15°	D	Contact Angle Approx 28°

External Seals, Shields	
Z	Shield on One Side Only
ZZ	Z Shields on Both Sides
DU	Contact Rubber Seal on One Side Only
DDU	DU Seals on Both Sides
V	Non-Contact Rubber Seal on One Side Only
VV	V Seals on Both Sides

Table 10.8 — Formulation of Bearing Numbers (continued) – Supplementary Symbols

Supplementary Features	Features			Features Design of Outer and Inner Ring			
	Arrangement						
	Radial Internal Clearance						
	Tolerance Class	Tolerance Class					
	Special Specifications						
	Spacer or Sleeve						
		(None)	ISO Class 0 (ABEC 1)	K	Tapered Bore (Taper 1:12)		
		P6	ISO Class 6 (ABEC 3)	K30	Tapered Bore (Taper 1:30)		
		P5	ISO Class 5 (ABEC 5)	E4	Lubrication Grooves and Holes in Outer Ring		
		P4	ISO Class 4 (ABEC 7)	N	Snap Ring Groove in Outer Ring		
				NR	Snap Ring Groove with Snap Ring in Outer Ring		
		Special Specifications		Arrangement			
		X28	Inner and Outer Rings Heat Stabilized for Maximum Working Temperature of 200°C	DB	Back to Back Duplex Arrangement		
		S11	Spherical Bearings Heat Stabilized to 200°C	DF	Face to Face Duplex Arrangement		
		P55	High Running Accuracy of Inner and Outer Rings	DT	Tandem Duplex Arrangement		
				SU	Single Universal – Bearings with front and back face stand-out adjusted to be equal		
				DU	Duplex Universal (SU sold as pair)		
		Spacer or Sleeve		Radial Internal Clearance			
	+K	Bearings with Outer Ring Spacer		C2	For All Radial Ball Bearings	Clearance Less Than Normal	
	+L	Bearings with Inner Ring Spacer		C0			Normal Clearance
	+KL	Bearings with Both Outer and Inner Ring Spacers		C3			Clearance Greater Than Normal
	+H	Adapter Designation		C4			Clearance Greater Than C3
	+AH	Withdrawal Sleeve Designation		CC1	For Matched Cylindrical Roller Bearings	Clearance Less Than C	
	HJ	Angle Ring Designation		CC2		Clearance Less Than Normal	
				CC		Normal Clearance	
				CC3		Clearance Greater Than Normal	
				CC4		Clearance Greater Than CC3	
				CC5	Clearance Greater Than CC4		
				MC2	For Extra Small Ball Bearings and Miniature Bearings	Clearance Less Than MC3	
				MC3		Normal Clearance	
				MC4		Clearance Greater Than MC3	
				MC5		Clearance Greater Than MC4	
	Lubrication						
	AKC	Exxon Andok C					
	AV2	Shell Alvania No. 2					
	B32	Exxon Beacon 325					
	SRI	Chevron SRI-2					
	SDR	Shell Dolium R					

Introduction
Ball Bearings
Cylindrical Roller Bearings
Spherical Roller Bearings
Tapered Roller Bearings
Thrust Bearings
Split Pillow Blocks
Super Precision Bearings
Linear Motion
Rolling Mill Bearings
Engineering Section

Snap Ring and Groove Dimensions

Table 10.9 — Snap Ring and Groove Dimensions (Dimension Series 0,2,3 & 4)

Units: inch

BEARING BORE d (mm)				SNAP RING GROOVE POSITION, a		GROOVE WIDTH, b	SNAP RING THICKNESS, f	SNAP RING O.D., D ₂	HOUSING BORE, D _x
DIMENSION SERIES									
0	2	3	4	0	2,3,4	med.	med.	max.	min.
10	—	—	—	0.0500	—	0.0402	0.0311	1.1299	1.1575
12	—	—	—	0.0500	—	0.0402	0.0311	1.2087	1.2362
—	10	9	8	—	0.0780	0.0591	0.0421	1.3661	1.3976
15	12	—	9	0.0780	0.0780	0.0591	0.0421	1.4449	1.4764
17	15	10	—	0.0780	0.0780	0.0591	0.0421	1.5630	1.5945
—	—	12	10	—	0.0780	0.0591	0.0421	1.6260	1.6535
—	17	—	—	—	0.0780	0.0591	0.0421	1.7559	1.7913
20	—	15	12	0.0780	0.0780	0.0591	0.0421	1.8228	1.8504
22	—	—	—	0.0780	—	0.0591	0.0421	1.9016	1.9291
25	20	17	—	0.0780	0.0939	0.0591	0.0421	2.0748	2.1063
—	22	—	—	—	0.0939	0.0591	0.0421	2.1929	2.2244
28	25	20	15	0.0780	0.0939	0.0591	0.0421	2.2795	2.3031
30	—	—	—	0.0780	—	0.0591	0.0421	2.3898	2.4213
—	—	22	—	—	0.0939	0.0591	0.0421	2.4291	2.4606
32	28	—	—	0.0780	0.0939	0.0591	0.0421	2.5079	2.5394
35	30	25	17	0.0780	0.1250	0.0807	0.0650	2.6654	2.6969
—	32	—	—	—	0.1250	0.0807	0.0650	2.7835	2.8150
40	—	28	—	0.0941	0.1250	0.0807	0.0650	2.9370	2.9921
—	35	30	20	—	0.1250	0.0807	0.0650	3.0945	3.1496
45	—	32	—	0.0941	0.1250	0.0807	0.0650	3.2126	3.2677
50	40	35	25	0.0941	0.1250	0.0807	0.0650	3.4094	3.4646
—	45	—	—	—	0.1250	0.0807	0.0650	3.6063	3.6614
55	50	40	30	0.1130	0.1250	0.1122	0.0949	3.7992	3.8583
60	—	—	—	0.1130	—	0.1122	0.0949	4.0000	4.0551
65	55	45	35	0.1130	0.1250	0.1122	0.0949	4.1929	4.2520
70	60	50	40	0.1130	0.1250	0.1122	0.0949	4.5906	4.6457
75	—	—	—	0.1130	—	0.1122	0.0949	4.7874	4.8425
—	65	55	45	—	0.1559	0.1280	0.1091	5.1063	5.1772
80	70	—	—	0.1130	0.1559	0.1280	0.1091	5.3031	5.3740
85	75	60	50	0.1130	0.1559	0.1280	0.1091	5.5000	5.5709
90	80	65	55	0.1409	0.1880	0.1280	0.1091	5.8937	5.9843
95	—	—	—	0.1409	—	0.1280	0.1091	6.0906	6.1811
100	85	70	60	0.1409	0.1880	0.1280	0.1091	6.2874	6.3780
105	90	75	65	0.1409	0.1880	0.1280	0.1091	6.6811	6.7717
110	95	80	—	0.1409	0.2191	0.1437	0.1437	7.2008	7.2835
120	100	85	70	0.1409	0.2191	0.1437	0.1437	7.5945	7.6772
—	105	90	75	—	0.2191	0.1437	0.1437	7.9882	8.0709
130	110	95	80	0.2191	0.2191	0.1437	0.1437	8.3819	8.4646

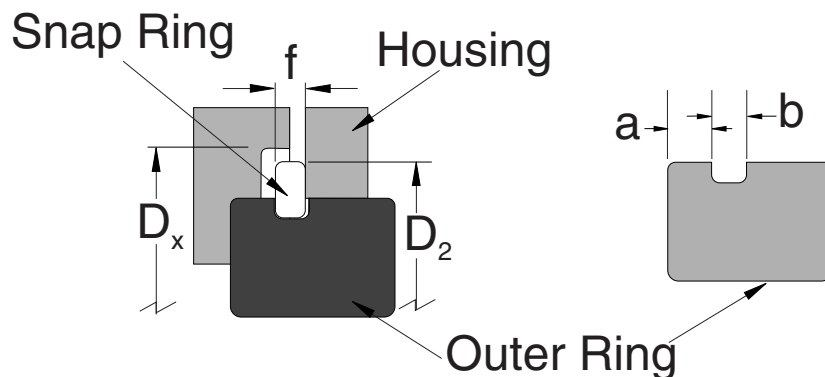
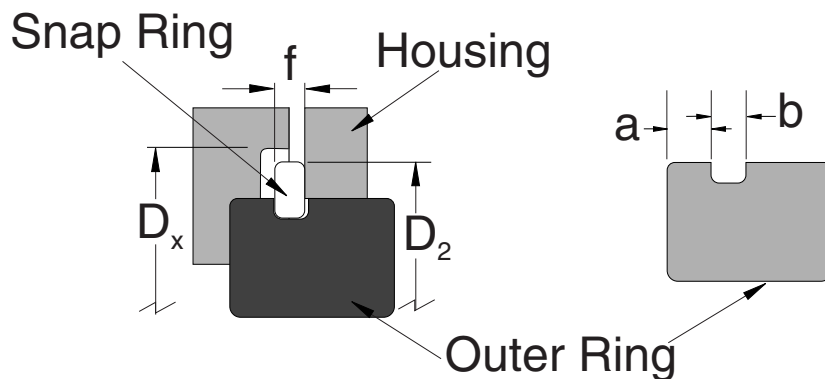

Table 10.10 — Snap Ring and Groove Dimensions (Series 6800 & 6900)

Units: inch

BEARING BORE d (mm)		SNAP RING GROOVE POSITION, a		GROOVE WIDTH, b	SNAP RING THICKNESS, f	SNAP RING O.D., D ₂	HOUSING BORE, D _x
DIMENSION SERIES							
8	9	8	9	med.	med.	max.	min.
—	10	—	1.0677	0.0222	0.0256	0.9764	1.0039
—	12	—	1.0677	0.0222	0.0256	1.0551	1.0827
—	15	—	1.3226	0.0423	0.0315	1.2126	1.2402
—	17	—	1.3226	0.0423	0.0315	1.2913	1.3189
20	—	0.0482	—	0.0423	0.0315	1.3701	1.3976
22	—	0.0482	—	0.0423	0.0315	1.4488	1.4764
25	20	0.0482	1.7305	0.0423	0.0315	1.5669	1.5945
—	22	—	1.7305	0.0423	0.0315	1.6457	1.6732
28	—	0.0482	—	0.0423	0.0315	1.6850	1.7126
30	25	0.0482	1.7305	0.0423	0.0315	1.7638	1.7913
32	—	0.0482	—	0.0423	0.0315	1.8425	1.8701
—	28	—	1.7305	0.0423	0.0315	1.8819	1.9094
35	30	0.0482	1.7305	0.0423	0.0315	1.9606	1.9882
40	32	0.0482	1.7305	0.0423	0.0315	2.1575	2.1850
—	35	—	1.7305	0.0423	0.0315	2.2756	2.3031
45	—	0.0482	—	0.0423	0.0315	2.3937	2.4213
—	40	—	1.7305	0.0423	0.0315	2.5512	2.5787
50	—	0.0482	—	0.0423	0.0315	2.6693	2.6969
—	45	—	1.7305	0.0571	0.0421	2.7874	2.8346
55	50	0.0640	1.7305	0.0571	0.0421	2.9449	2.9921
60	—	0.0640	—	0.0571	0.0421	3.2559	3.3071
—	55	—	2.1374	0.0571	0.0421	3.3228	3.3858
65	60	0.0640	2.1374	0.0571	0.0421	3.5197	3.5827
70	65	0.0640	2.1374	0.0571	0.0421	3.7165	3.7795
75	—	0.0640	—	0.0571	0.0421	3.9134	3.9764
80	70	0.0640	2.5453	0.0571	0.0421	4.1102	4.1732
—	75	—	2.5453	0.0571	0.0421	4.3583	4.4094
85	80	0.0787	2.5453	0.0571	0.0421	4.5551	4.6063
90	—	0.0787	—	0.0571	0.0421	4.7520	4.8031
95	85	0.0787	3.3610	0.0571	0.0421	4.9488	5.0000
100	90	0.0787	3.3610	0.0571	0.0421	5.1457	5.1969
105	95	0.0787	3.3610	0.0571	0.0421	5.3425	5.3937
110	100	0.0945	3.3610	0.0807	0.0650	5.7362	5.7874
—	105	—	3.3610	0.0807	0.0650	5.9331	5.9843
120	110	0.0945	3.3610	0.0807	0.0650	6.1299	6.1811
130	120	0.1260	3.3610	0.0807	0.0650	6.7520	6.8110
140	—	0.1260	—	0.0807	0.0650	7.1457	7.2047
—	130	—	3.3610	0.0807	0.0650	7.3425	7.4016
150	140	0.1260	3.3610	0.0807	0.0650	7.7362	7.7953
160	—	0.1260	—	0.0807	0.0650	8.1299	8.1890



Introduction

Ball Bearings

Cylindrical Roller Bearings

Spherical Roller Bearings

Tapered Roller Bearings

Thrust Bearings

Split Pillow Blocks

Super Precision Bearings

Linear Motion

Rolling Mill Bearings

Engineering Section

Bearing Tolerances

BEARING TOLERANCE STANDARDS

The dimensional and running accuracies of rolling bearings are standardized by ISO with regard to the following items:

- Tolerances for bore diameter, outer diameter, individual ring width, and overall width.
- Tolerances for absolute dimensions of inscribed circle diameter and circumscribed circle diameter.
- Tolerances for chamfer dimension.
- Tolerances for width variations
- Tolerances for taper angle and taper bore diameters
- Tolerances for radial runout of inner ring and outer rings.
- Tolerances for axial runout of inner and outer rings.
- Tolerances for side or face runout of inner ring.
- Tolerances for side or face runout of outer ring.

In grading bearing tolerances, ISO “normal class” represents the standard. ISO classes 6, 5, 4, and 2 represent four higher grades. In general, DIN, JIS, and ABMA tolerance classes conform to these ISO standards. Tolerance classes applicable to each bearing type are shown in the subsequent tables.

Table 10.11 — Bearing Types and Tolerance Classes

Bearing Types		Applicable Tolerance Classes					Applicable Tables	Applicable Pages	
Angular Contact Ball Bearings		Class N	Class 6	Class 5	Class 4	Class 2	9-12 to 9-16	236 to 239	
Self-Aligning Ball Bearings		Class N	Class 6 equivalent	Class 5 equivalent	–	–			
Cylindrical Roller Bearings		Class N	Class 6	Class 5	Class 4	Class 2			
Spherical Roller Bearings		Class N	Class 6 equivalent	Class 5 equivalent	–	–			
Tapered Roller Bearings	Metric Design	Class N Class 6X	–	Class 5	Class 4	–	9-17 to 9-21	240 to 242	
	Inch Design	ABMA Class 4	ABMA Class 2	ABMA Class 3	ABMA Class 0	ABMA Class 00	9-22 to 9-24	244 to 244	
Thrust Ball Bearings		Class N	Class 6	Class 5	Class 4	–	9-25 to 9-27	246 to 247	
Spherical Roller Thrust Bearings		Class N	–	–	–	–	9-28 to 9-29	248 to 248	
Equivalent Standards (ref.)	JIS ¹		Class 0	Class 6	Class 5	Class 4	Class 2	–	–
	DIN ²		0	P6	P5	P4	P2	–	–
	ABMA ³	Ball Bearings	ABEC 1	ABEC 3	ABEC 5 (Class 5P)	ABEC 7 (Class 7P)	ABEC 9 (Class 9P)	9-12 to 9-16	236 to 239
		Roller Bearings	RBEC 1	RBEC 3	RBEC 5			–	–
	Tapered Roller Bearings	Class 4	Class 2	Class 3	Class 0	Class 00	9-22 to 9-24	244 to 244	

1) JIS: Japanese Industrial Standards, 2) DIN: Deutch Industrie Norm, 3) ABMA: American Bearing Manufacturers Association

Bearing Tolerance Nomenclature

Rough definitions of the items listed above for running accuracy and their measuring methods are shown below. They are described in detail in ISO 5593 (Rolling Bearings-Vocabulary), JIS B 1515 (Measuring Methods for Rolling Bearings), and elsewhere.

Symbols for Boundary Dimensions and Running Accuracy

d Bearing bore diameter, nominal	Δ_{Ts} Deviation of the actual bearing width
Δ_{ds} Deviation of single bore diameter	D Bearing outside diameter, nominal
Δ_{dmp} Single plane mean bore diameter deviation	Δ_{Ds} Deviation of a single outside diameter
V_{dp} Bore diameter variation in a single radial plane	Δ_{Dmp} Single plane mean outside diameter deviation
V_{dmp} Mean bore diameter variation	V_{Dp} Outside diameter variation in a single radial plane
B Inner ring width, nominal	V_{Dmp} Mean outside diameter variation
Δ_{Bs} Deviation of a single inner ring width	C Outer ring width, nominal
V_{Bs} Inner ring width variation	Δ_{Cs} Deviation of a single outer ring width
K_{ia} Radial runout of assembled bearing inner ring	V_{Cs} Outer ring width variation
S_d Inner ring reference face (backface, where applicable) runout with bore	K_{ea} Radial runout of assembled bearing outer ring
S_{ia} Assembled bearing inner ring face (backface) runout with raceway	S_D Variation of bearing outside surface generatrix inclination with outer ring reference face (backface)
S_i, S_e Raceway to backface thickness variation of thrust bearing	S_{ea} Assembled bearing outer ring (backface) runout with raceway
T Bearing width, nominal	

Measuring Methods for Running Accuracy (summarized)

Illustrations	Running Accuracy	Inner Ring	Outer Ring	Dial Gage
	K_{ia}	Rotating	Stationary	A
	K_{ea}	Stationary	Rotating	A
	S_{ia}	Rotating	Stationary	B1
	S_{ea}	Stationary	Rotating	B2
	S_d	Rotating	Stationary	C
	S_D	-	Rotating	D
	S_i, S_e	Only the shaft or housing or central washer is to be rotated.		E

Table 10.12 — Tolerances for Inner Ring Bore of Radial Bearings (excluding Tapered Roller Bearings)



Units: inch

Nominal Bore Diameter <i>d</i> (mm)		$\Delta dmp(1)$										<i>ds</i> (1)			
		Class N		Class 6		Class 5		Class 4		Class 2		Class 4 Diameter Series 0, 1, 2, 3, 4		Class 2	
over	incl	high	low	high	low	high	low	high	low	high	low	high	low	high	low
0.6 ²⁾	2.5	0	-0.003	0	-0.003	0	-0.002	0	-0.002	0	-0.001	0	-0.002	0	-0.001
2.5	10	0	-0.003	0	-0.003	0	-0.002	0	-0.002	0	-0.001	0	-0.002	0	-0.001
10	18	0	-0.003	0	-0.003	0	-0.002	0	-0.002	0	-0.001	0	-0.002	0	-0.001
18	30	0	-0.004	0	-0.003	0	-0.002	0	-0.002	0	-0.001	0	-0.002	0	-0.001
30	50	0	-0.005	0	-0.004	0	-0.003	0	-0.002	0	-0.001	0	-0.002	0	-0.001
50	80	0	-0.006	0	-0.005	0	-0.004	0	-0.003	0	-0.002	0	-0.003	0	-0.002
80	120	0	-0.008	0	-0.006	0	-0.004	0	-0.003	0	-0.002	0	-0.003	0	-0.002
120	150	0	-0.010	0	-0.007	0	-0.005	0	-0.004	0	-0.003	0	-0.004	0	-0.003
150	180	0	-0.010	0	-0.007	0	-0.005	0	-0.004	0	-0.003	0	-0.004	0	-0.003
180	250	0	-0.012	0	-0.009	0	-0.006	0	-0.005	0	-0.003	0	-0.005	0	-0.003
250	315	0	-0.014	0	-0.010	0	-0.007	-	-	-	-	-	-	-	-
315	400	0	-0.016	0	-0.012	0	-0.009	-	-	-	-	-	-	-	-
400	500	0	-0.018	0	-0.014	-	-	-	-	-	-	-	-	-	-
500	630	0	-0.020	0	-0.016	-	-	-	-	-	-	-	-	-	-
630	800	0	-0.030	-	-	-	-	-	-	-	-	-	-	-	-
800	1000	0	-0.039	-	-	-	-	-	-	-	-	-	-	-	-
1000	1250	0	-0.049	-	-	-	-	-	-	-	-	-	-	-	-
1250	1600	0	-0.063	-	-	-	-	-	-	-	-	-	-	-	-
1600	2000	0	-0.079	-	-	-	-	-	-	-	-	-	-	-	-

Note: 1) Applicable to bearings with cylindrical bores.
2) 0.6 mm is included in this group.

Table 10.13 — Tolerances for Outer Ring O.D. of Radial Bearings (excluding Tapered Roller Bearings)



Units: inch

Nominal Outside Diameter <i>D</i> (mm)		ΔDmp										ΔDs			
		Class N		Class 6		Class 5		Class 4		Class 2		Class 4 Diameter Series 0, 1, 2, 3, 4		Class 2	
over	incl	high	low	high	low	high	low	high	low	high	low	high	low	high	low
2.5 ¹⁾	6	0	-0.003	0	-0.003	0	-0.002	0	-0.002	0	-0.001	0	-0.002	0	-0.001
6	18	0	-0.003	0	-0.003	0	-0.002	0	-0.002	0	-0.001	0	-0.002	0	-0.001
18	30	0	-0.004	0	-0.003	0	-0.002	0	-0.002	0	-0.002	0	-0.002	0	-0.002
30	50	0	-0.004	0	-0.004	0	-0.003	0	-0.002	0	-0.002	0	-0.002	0	-0.002
50	80	0	-0.005	0	-0.004	0	-0.004	0	-0.003	0	-0.002	0	-0.003	0	-0.002
80	120	0	-0.006	0	-0.005	0	-0.004	0	-0.003	0	-0.002	0	-0.003	0	-0.002
120	150	0	-0.007	0	-0.006	0	-0.004	0	-0.004	0	-0.002	0	-0.004	0	-0.002
150	180	0	-0.010	0	-0.007	0	-0.005	0	-0.004	0	-0.003	0	-0.004	0	-0.003
180	250	0	-0.012	0	-0.008	0	-0.006	0	-0.004	0	-0.003	0	-0.004	0	-0.003
250	315	0	-0.014	0	-0.010	0	-0.007	0	-0.005	0	-0.003	0	-0.005	0	-0.003
315	400	0	-0.016	0	-0.011	0	-0.008	0	-0.006	0	-0.004	0	-0.006	0	-0.004
400	500	0	-0.018	0	-0.013	0	-0.009	-	-	-	-	-	-	-	-
500	630	0	-0.020	0	-0.015	0	-0.011	-	-	-	-	-	-	-	-
630	800	0	-0.030	0	-0.018	0	-0.014	-	-	-	-	-	-	-	-
800	1000	0	-0.039	0	-0.024	-	-	-	-	-	-	-	-	-	-
1000	1250	0	-0.049	-	-	-	-	-	-	-	-	-	-	-	-
1250	1600	0	-0.063	-	-	-	-	-	-	-	-	-	-	-	-
1600	2000	0	-0.079	-	-	-	-	-	-	-	-	-	-	-	-
2000	2500	0	-0.098	-	-	-	-	-	-	-	-	-	-	-	-

Note: 1) 2.5 mm is included within this group.
Remarks: 1) The outside diameter low tolerances specified in this table do not apply within a distance of 1.2 times the chamfer dimension *r* (max) from the ring face.
2) The cylindrical bore diameter "no-go" side" tolerance limit (high) specified in this table does not necessarily apply within a distance of 1.2 times the chamfer dimension *r* (max) from the ring face.
3) ABMA Std 20-1987 was amended: ABEC1 ° RBEC1, ABEC3 ° RBEC3, ABEC5 ° RBEC5, ABEC7, and ABEC9 are equivalent to Classes N, 6,5,4, and 2 respectively.

Introduction
Ball Bearings
Cylindrical Roller Bearings
Spherical Roller Bearings
Tapered Roller Bearings
Thrust Bearings
Split Pillow Blocks
Super Precision Bearings
Linear Motion
Rolling Mill Bearings
Engineering Section

Table 10.12 —Tolerances for Inner Ring Bore of Radial Bearings (excluding Tapered Roller Bearings) (continued)

Units: inch															
$V_{dp}^{(1)}$										$V_{dmp}^{(1)}$					
Class N			Class 6			Class 5		Class 4		Class	Class				
Diameter Series			Diameter Series			Dia. Series		Dia. Series			2	N	6	5	4
7,8,9	0,1	2,3,4	7,8,9	0,1	2,3,4	7,8,9	0,1,2,3,4	7,8,9	0,1,2,3,4	max					
max	max	max	max	max	max	max	max	max	max	max	max	max	max	max	max
+0.004	+0.003	+0.002	+0.004	+0.003	+0.002	+0.002	+0.002	+0.002	+0.001	+0.001	+0.002	+0.002	+0.001	+0.001	+0.001
+0.004	+0.003	+0.002	+0.004	+0.003	+0.002	+0.002	+0.002	+0.002	+0.001	+0.001	+0.002	+0.002	+0.001	+0.001	+0.001
+0.004	+0.003	+0.002	+0.004	+0.003	+0.002	+0.002	+0.002	+0.002	+0.001	+0.001	+0.002	+0.002	+0.001	+0.001	+0.001
+0.005	+0.004	+0.003	+0.004	+0.003	+0.002	+0.002	+0.002	+0.002	+0.001	+0.001	+0.003	+0.002	+0.001	+0.001	+0.001
+0.006	+0.005	+0.004	+0.005	+0.004	+0.003	+0.003	+0.002	+0.002	+0.001	+0.001	+0.004	+0.003	+0.002	+0.001	+0.001
+0.007	+0.007	+0.004	+0.006	+0.006	+0.004	+0.004	+0.003	+0.003	+0.002	+0.002	+0.004	+0.004	+0.002	+0.001	+0.001
+0.010	+0.010	+0.006	+0.007	+0.007	+0.004	+0.004	+0.003	+0.003	+0.002	+0.002	+0.006	+0.004	+0.002	+0.002	+0.001
+0.012	+0.012	+0.007	+0.009	+0.009	+0.006	+0.005	+0.004	+0.004	+0.003	+0.003	+0.007	+0.006	+0.003	+0.002	+0.001
+0.012	+0.012	+0.007	+0.009	+0.009	+0.006	+0.005	+0.004	+0.004	+0.003	+0.003	+0.007	+0.006	+0.003	+0.002	+0.001
+0.015	+0.015	+0.009	+0.011	+0.011	+0.007	+0.006	+0.005	+0.005	+0.004	+0.003	+0.009	+0.007	+0.003	+0.002	+0.002
+0.017	+0.017	+0.010	+0.012	+0.012	+0.007	+0.007	+0.006	-	-	-	+0.010	+0.007	+0.004	-	-
+0.020	+0.020	+0.012	+0.015	+0.015	+0.009	+0.009	+0.007	-	-	-	+0.012	+0.009	+0.005	-	-
+0.022	+0.022	+0.013	+0.017	+0.017	+0.010	-	-	-	-	-	+0.013	+0.010	-	-	-
+0.025	+0.025	+0.015	+0.020	+0.020	+0.012	-	-	-	-	-	+0.015	+0.012	-	-	-
-	-	-	-	-	-	-	-	-	-	-	-	-	-	-	-
-	-	-	-	-	-	-	-	-	-	-	-	-	-	-	-
-	-	-	-	-	-	-	-	-	-	-	-	-	-	-	-
-	-	-	-	-	-	-	-	-	-	-	-	-	-	-	-

Note: 1) Applicable to bearings with cylindrical bores.

Table 10.13 —Tolerances for Outer Ring O.D. of Radial Bearings (excluding Tapered Roller Bearings) (continued)

Units: inch																
$V_{dp}^{(1)}$										$V_{dmp}^{(1)}$						
Class N			Class 6			Class 5		Class 4		Class 2	Class					
Open Type		Shielded Sealed	Open Type		Shielded Sealed	Open Type		Open Type			Open Type	N	6	5	4	2
Diameter Series			Diameter Series			Dia. Series		Dia. Series								
7,8,9	0,1	2,3,4	2,3,4	7,8,9	0,1	2,3,4	0,1,2,3,4	7,8,9	0,1,2,3,4	7,8,9	0,1,2,3,4	max	max	max	max	max
max	max	max	max	max	max	max	max	max	max	max	max	max	max	max	max	max
+0.004	+0.003	+0.002	+0.004	+0.004	+0.003	+0.002	+0.004	+0.002	+0.002	+0.002	+0.001	+0.001	+0.002	+0.002	+0.001	+0.001
+0.005	+0.004	+0.003	+0.005	+0.004	+0.003	+0.002	+0.004	+0.002	+0.002	+0.002	+0.002	+0.002	+0.003	+0.002	+0.001	+0.001
+0.006	+0.004	+0.003	+0.006	+0.004	+0.004	+0.003	+0.005	+0.003	+0.002	+0.002	+0.002	+0.002	+0.003	+0.003	+0.002	+0.001
+0.006	+0.005	+0.004	+0.008	+0.006	+0.004	+0.003	+0.006	+0.003	+0.003	+0.003	+0.002	+0.002	+0.004	+0.003	+0.002	+0.001
+0.007	+0.007	+0.004	+0.010	+0.006	+0.006	+0.004	+0.008	+0.004	+0.003	+0.003	+0.002	+0.002	+0.004	+0.004	+0.002	+0.002
+0.009	+0.009	+0.006	+0.012	+0.007	+0.007	+0.004	+0.010	+0.004	+0.003	+0.004	+0.003	+0.002	+0.006	+0.004	+0.002	+0.001
+0.012	+0.012	+0.007	+0.015	+0.009	+0.009	+0.006	+0.012	+0.005	+0.004	+0.004	+0.003	+0.003	+0.007	+0.006	+0.003	+0.002
+0.015	+0.015	+0.009	-	+0.010	+0.010	+0.006	-	+0.006	+0.004	+0.004	+0.003	+0.003	+0.009	+0.006	+0.003	+0.002
+0.017	+0.017	+0.010	-	+0.012	+0.012	+0.007	-	+0.007	+0.006	+0.005	+0.004	+0.003	+0.010	+0.007	+0.004	+0.003
+0.020	+0.020	+0.012	-	+0.014	+0.014	+0.008	-	+0.008	+0.006	+0.006	+0.004	+0.004	+0.012	+0.008	+0.004	+0.003
+0.022	+0.022	+0.013	-	+0.016	+0.016	+0.010	-	+0.009	+0.007	-	-	-	+0.013	+0.010	+0.005	-
+0.025	+0.025	+0.015	-	+0.019	+0.019	+0.011	-	+0.011	+0.008	-	-	-	+0.015	+0.011	+0.006	-
+0.037	+0.037	+0.022	-	+0.022	+0.022	+0.013	-	+0.014	+0.010	-	-	-	+0.022	+0.013	+0.007	-
+0.049	+0.049	+0.030	-	+0.030	+0.030	+0.018	-	-	-	-	-	-	+0.030	+0.018	-	-
-	-	-	-	-	-	-	-	-	-	-	-	-	-	-	-	-
-	-	-	-	-	-	-	-	-	-	-	-	-	-	-	-	-
-	-	-	-	-	-	-	-	-	-	-	-	-	-	-	-	-
-	-	-	-	-	-	-	-	-	-	-	-	-	-	-	-	-

Note: 1) Applicable only when a locating snap ring is not used

Introduction
Ball Bearings
Cylindrical Roller Bearings
Spherical Roller Bearings
Tapered Roller Bearings
Thrust Bearings
Split Pillow Blocks
Super Precision Bearings
Linear Motion
Rolling Mill Bearings
Engineering Section

Table 10.14 — Tolerances for Inner and Outer Ring Widths of Radial Bearings (excluding Tapered Roller Bearings)

Units: inch

Nominal Bore Diameter <i>d</i> (mm)		ΔB_s (or C_s) ⁽¹⁾										V_{Bs} (or V_{Cs}) ⁽¹⁾				
		Single Bearing						Combined Bearings ⁽²⁾				Inner Ring (or Outer Ring) ⁽²⁾		Inner Ring		
		Class N Class 6		Class 5 Class 4		Class 2		Class N Class 6		Class 5 Class 4		Class		Class		
		high	low	high	low	high	low	high	low	high	low	N	6	5	4	2
over	incl	high	low	high	low	high	low	high	low	high	low	max	max	max	max	max
0.6 ³⁾	2.5	0	-0.016	0	-0.016	0	-0.016	—	—	0	-0.098	+0.005	+0.005	+0.002	+0.001	+0.001
2.5	10	0	-0.047	0	-0.047	0	-0.047	0	-0.098	0	-0.098	+0.006	+0.006	+0.002	+0.001	+0.001
10	18	0	-0.047	0	-0.047	0	-0.047	0	-0.098	0	-0.098	+0.008	+0.008	+0.002	+0.001	+0.001
18	30	0	-0.047	0	-0.047	0	-0.047	0	-0.098	0	-0.098	+0.008	+0.008	+0.002	+0.001	+0.001
30	50	0	-0.047	0	-0.047	0	-0.047	0	-0.098	0	-0.098	+0.008	+0.008	+0.002	+0.001	+0.001
50	80	0	-0.059	0	-0.059	0	-0.059	0	-0.150	0	-0.150	+0.010	+0.010	+0.002	+0.002	+0.001
80	120	0	-0.079	0	-0.079	0	-0.079	0	-0.150	0	-0.150	+0.010	+0.010	+0.003	+0.002	+0.001
120	150	0	-0.098	0	-0.098	0	-0.098	0	-0.197	0	-0.150	+0.012	+0.012	+0.003	+0.002	+0.001
150	180	0	-0.098	0	-0.098	0	-0.118	0	-0.197	0	-0.150	+0.012	+0.012	+0.003	+0.002	+0.002
180	250	0	-0.118	0	-0.118	0	-0.138	0	-0.197	0	-0.197	+0.012	+0.012	+0.004	+0.002	+0.002
250	315	0	-0.138	0	-0.138	—	—	0	-0.197	0	-0.197	+0.014	+0.014	+0.005	—	—
315	400	0	-0.157	0	-0.157	—	—	0	-0.248	0	-0.248	+0.016	+0.016	+0.006	—	—
400	500	0	-0.177	—	—	—	—	—	—	—	—	+0.020	+0.018	—	—	—
500	630	0	-0.197	—	—	—	—	—	—	—	—	+0.024	+0.020	—	—	—
630	800	0	-0.295	—	—	—	—	—	—	—	—	+0.028	—	—	—	—
800	1000	0	-0.394	—	—	—	—	—	—	—	—	+0.031	—	—	—	—
1000	1250	0	-0.492	—	—	—	—	—	—	—	—	+0.039	—	—	—	—
1250	1600	0	-0.630	—	—	—	—	—	—	—	—	+0.047	—	—	—	—
1600	2000	0	-0.787	—	—	—	—	—	—	—	—	+0.055	—	—	—	—

Note: 1) Tolerance for width deviation and tolerance limits for the width variation of the outer ring should be the same.
 2) Applicable to individual rings manufactured for combined bearings.
 3) 0.6 mm is included in this group.

Table 10.15 — Tolerances for Inner Ring Runout of Radial Bearings (excluding Tapered Roller Bearings)

Units: inch

Nominal Bore Diameter <i>d</i> (mm)		K_{ia}					S_d			S_{ia} ⁽¹⁾		
		Class N	Class 6	Class 5	Class 4	Class 2	Class 5	Class 4	Class 2	Class 5	Class 4	Class 2
		max	max	max	max	max	max	max	max	max	max	max
over	incl	max	max	max	max	max	max	max	max	max	max	
0.6 ²⁾	2.5	+0.004	+0.002	+0.002	+0.001	+0.001	+0.003	+0.001	+0.001	+0.003	+0.001	+0.001
2.5	10	+0.004	+0.002	+0.002	+0.001	+0.001	+0.003	+0.001	+0.001	+0.003	+0.001	+0.001
10	18	+0.004	+0.003	+0.002	+0.001	+0.001	+0.003	+0.001	+0.001	+0.003	+0.001	+0.001
18	30	+0.005	+0.003	+0.002	+0.001	+0.001	+0.003	+0.002	+0.001	+0.003	+0.002	+0.001
30	50	+0.006	+0.004	+0.002	+0.002	+0.001	+0.003	+0.002	+0.001	+0.003	+0.002	+0.001
50	80	+0.008	+0.004	+0.002	+0.002	+0.001	+0.003	+0.002	+0.001	+0.003	+0.002	+0.001
80	120	+0.010	+0.005	+0.002	+0.002	+0.001	+0.004	+0.002	+0.001	+0.004	+0.002	+0.001
120	150	+0.012	+0.007	+0.003	+0.002	+0.001	+0.004	+0.002	+0.001	+0.004	+0.003	+0.001
150	180	+0.012	+0.007	+0.003	+0.002	+0.002	+0.004	+0.002	+0.002	+0.004	+0.003	+0.002
180	250	+0.016	+0.008	+0.004	+0.003	+0.002	+0.004	+0.003	+0.002	+0.005	+0.003	+0.002
250	315	+0.020	+0.010	+0.005	—	—	+0.005	—	—	+0.006	—	—
315	400	+0.024	+0.012	+0.006	—	—	+0.006	—	—	+0.008	—	—
400	500	+0.026	+0.014	—	—	—	—	—	—	—	—	—
500	630	+0.028	+0.016	—	—	—	—	—	—	—	—	—
630	800	+0.031	—	—	—	—	—	—	—	—	—	—
800	1000	+0.035	—	—	—	—	—	—	—	—	—	—
1000	1250	+0.039	—	—	—	—	—	—	—	—	—	—
1250	1600	+0.047	—	—	—	—	—	—	—	—	—	—
1600	2000	+0.055	—	—	—	—	—	—	—	—	—	—

Note: 1) Applicable to ball bearings only.
 2) 0.6mm is included in this group

Table 10.16 — Tolerances for Outer Ring Runout of Radial Bearings (excluding Tapered Roller Bearings)

Units: inch

Nominal Outside Diameter D (mm)		K_{ea}					S_D			$S_{ea}^{(1)}$			$V_{Cs}^{(2)}$		
		Class					Class			Class			Class		
		N	6	5	4	2	5	4	2	5	4	2	5	4	2
over	incl	max	max	max	max	max	max	max	max	max	max	max	max	max	
2.5 ³⁾	6	+0.006	+0.003	+0.002	+0.001	+0.001	+0.003	+0.002	+0.001	+0.003	+0.002	+0.001	+0.002	+0.001	+0.001
6	18	+0.006	+0.003	+0.002	+0.001	+0.001	+0.003	+0.002	+0.001	+0.003	+0.002	+0.001	+0.002	+0.001	+0.001
18	30	+0.006	+0.004	+0.002	+0.002	+0.001	+0.003	+0.002	+0.001	+0.003	+0.002	+0.001	+0.002	+0.001	+0.001
30	50	+0.008	+0.004	+0.003	+0.002	+0.001	+0.003	+0.002	+0.001	+0.003	+0.002	+0.001	+0.002	+0.001	+0.001
50	80	+0.010	+0.005	+0.003	+0.002	+0.002	+0.003	+0.002	+0.001	+0.004	+0.002	+0.002	+0.002	+0.001	+0.001
80	120	+0.014	+0.007	+0.004	+0.002	+0.002	+0.004	+0.002	+0.001	+0.004	+0.002	+0.002	+0.003	+0.002	+0.001
120	150	+0.016	+0.008	+0.004	+0.003	+0.002	+0.004	+0.002	+0.001	+0.005	+0.003	+0.002	+0.003	+0.002	+0.001
150	180	+0.018	+0.009	+0.005	+0.003	+0.002	+0.004	+0.002	+0.001	+0.006	+0.003	+0.002	+0.003	+0.002	+0.001
180	250	+0.020	+0.010	+0.006	+0.004	+0.003	+0.004	+0.003	+0.002	+0.006	+0.004	+0.003	+0.004	+0.003	+0.002
250	315	+0.024	+0.012	+0.007	+0.004	+0.003	+0.005	+0.003	+0.002	+0.007	+0.004	+0.003	+0.004	+0.003	+0.002
315	400	+0.028	+0.014	+0.008	+0.005	+0.003	+0.005	+0.004	+0.003	+0.008	+0.005	+0.003	+0.005	+0.003	+0.003
400	500	+0.031	+0.016	+0.009	-	-	+0.006	-	-	+0.009	-	-	+0.006	-	-
500	630	+0.039	+0.020	+0.010	-	-	+0.007	-	-	+0.010	-	-	+0.007	-	-
630	800	+0.047	+0.024	+0.012	-	-	+0.008	-	-	+0.012	-	-	+0.008	-	-
800	1000	+0.055	+0.030	-	-	-	-	-	-	-	-	-	-	-	-
1000	1250	+0.063	-	-	-	-	-	-	-	-	-	-	-	-	-
1250	1600	+0.075	-	-	-	-	-	-	-	-	-	-	-	-	-
1600	2000	+0.087	-	-	-	-	-	-	-	-	-	-	-	-	-
2000	2500	+0.098	-	-	-	-	-	-	-	-	-	-	-	-	-

Note: 1) Tolerance for width deviation and tolerance limits for the width variation of the outer ring should be the same bearing.
 2) Applicable to individual rings manufactured for combined bearings.
 3) 2.5mm is included within this group

Introduction
Ball Bearings
Cylindrical Roller Bearings
Spherical Roller Bearings
Tapered Roller Bearings
Thrust Bearings
Split Pillow Blocks
Super Precision Bearings
Linear Motion
Rolling Mill Bearings
Engineering Section

Table 10.17 — Tolerances for Inner Ring Bore Diameter of Metric Tapered Roller Bearings

Units: inch

Nominal Bore Diameter <i>d</i> (mm)		Δdmp						Δds		Vdp				$Vdmp$				
		Class N Class 6X		Class 6 Class 5		Class 4		Class 4		Class				Class				
		over	incl	high	low	high	low	high	low	high	low	N,6X	6	5	4	N,6X	6	5
10	18	0	-.0003	0	-.0003	0	-.0002	0	-.0002	+.0003	+.0003	+.0002	+.0002	+.0002	+.0002	+.0002	+.0002	+.0002
18	30	0	-.0004	0	-.0003	0	-.0002	0	-.0002	+.0004	+.0003	+.0002	+.0002	+.0003	+.0002	+.0002	+.0002	+.0002
30	50	0	-.0005	0	-.0004	0	-.0003	0	-.0003	+.0005	+.0004	+.0003	+.0002	+.0004	+.0003	+.0002	+.0002	+.0002
50	80	0	-.0006	0	-.0005	0	-.0004	0	-.0004	+.0006	+.0005	+.0004	+.0003	+.0004	+.0004	+.0004	+.0002	+.0002
80	120	0	-.0008	0	-.0006	0	-.0004	0	-.0004	+.0008	+.0006	+.0004	+.0003	+.0006	+.0004	+.0003	+.0002	+.0002
120	180	0	-.0010	0	-.0007	0	-.0005	0	-.0005	+.0010	+.0007	+.0006	+.0004	+.0007	+.0006	+.0004	+.0003	+.0003
180	250	0	-.0012	0	-.0009	0	-.0006	0	-.0006	+.0012	+.0009	+.0007	+.0004	+.0009	+.0006	+.0004	+.0003	+.0003
250	315	0	-.0014	0	-.0010	0	-.0007	0	-.0007	+.0014	-	-	-	+.0010	-	-	-	-
315	400	0	-.0016	0	-.0012	0	-.0009	0	-.0009	+.0016	-	-	-	+.0012	-	-	-	-
400	500	0	-.0018	0	-.0014	0	-.0011	0	-.0011	-	-	-	-	-	-	-	-	-
500	630	0	-.0020	0	-.0016	-	-	-	-	-	-	-	-	-	-	-	-	-
630	800	0	-.0030	0	-.0024	-	-	-	-	-	-	-	-	-	-	-	-	-

Remarks: 1. The outside diameter "no-go side" tolerances (high) specified in this table do not necessarily apply within a distance of 1.2 times the chamfer dimension *r* (max) from the ring face.
 2. Some of these tolerances conform to the NSK standard, and not ISO standards.

Table 10.18 — Tolerances for Outer Ring Diameter of Metric Tapered Roller Bearings

Units: inch

Nominal Outside Diameter <i>D</i> (mm)		Δdmp						Δds		Vdp				$Vdmp$				
		Class N Class 6X		Class 6 Class 5		Class 4		Class 4		Class				Class				
		over	incl	high	low	high	low	high	low	high	low	N,6X	6	5	4	N,6X	6	5
18	30	0	-.0004	0	-.0003	0	-.0002	0	-.0002	+.0004	+.0003	+.0002	+.0002	+.0003	+.0002	+.0002	+.0002	+.0002
30	50	0	-.0004	0	-.0004	0	-.0003	0	-.0003	+.0004	+.0004	+.0003	+.0002	+.0003	+.0003	+.0002	+.0002	+.0002
50	80	0	-.0005	0	-.0004	0	-.0004	0	-.0004	+.0005	+.0004	+.0003	+.0003	+.0004	+.0003	+.0002	+.0002	+.0002
80	120	0	-.0006	0	-.0005	0	-.0004	0	-.0004	+.0006	+.0005	+.0004	+.0003	+.0004	+.0004	+.0003	+.0002	+.0002
120	150	0	-.0007	0	-.0006	0	-.0004	0	-.0004	+.0007	+.0006	+.0004	+.0003	+.0006	+.0004	+.0003	+.0002	+.0002
150	180	0	-.0010	0	-.0007	0	-.0005	0	-.0005	+.0010	+.0007	+.0006	+.0004	+.0007	+.0006	+.0004	+.0003	+.0003
180	250	0	-.0012	0	-.0008	0	-.0006	0	-.0006	+.0012	+.0008	+.0006	+.0004	+.0009	+.0006	+.0004	+.0003	+.0003
250	315	0	-.0014	0	-.0010	0	-.0007	0	-.0007	+.0014	+.0010	+.0007	+.0006	+.0010	+.0007	+.0005	+.0004	+.0004
315	400	0	-.0016	0	-.0011	0	-.0008	0	-.0008	+.0016	+.0011	+.0009	+.0006	+.0012	+.0008	+.0006	+.0004	+.0004
400	500	0	-.0018	0	-.0013	0	-.0009	0	-.0009	+.0018	-	-	-	+.0013	-	-	-	-
500	630	0	-.0020	0	-.0015	-	-.0011	-	-.0011	+.0020	-	-	-	+.0015	-	-	-	-
630	800	0	-.0030	0	-.0018	-	-	-	-	-	-	-	-	-	-	-	-	-
800	1000	0	-.0039	0	-.0024	-	-	-	-	-	-	-	-	-	-	-	-	-

Remarks: 1. The outside diameter "no-go side" tolerances (high) specified in this table do not necessarily apply within a distance of 1.2 times the chamfer dimension *r* (max) from the ring face.
 2. Some of these tolerances conform to the NSK standard, and not ISO standards.

Table 10.19 — Tolerances for Inner Ring Running Accuracy of Metric Tapered Bearings

Units: inch

Nominal Bore Diameter d (mm)		K _{ia}				S _d		S _{ia}
		Class N Class 6X	Class 6	Class 5	Class 4	Class 5	Class 4	Class 4
over	incl	max	max	max	max	max	max	max
10	18	+0.0006	+0.0003	+0.0001	+0.0001	+0.0003	+0.0001	+0.0001
18	30	+0.0007	+0.0003	+0.0002	+0.0001	+0.0003	+0.0002	+0.0002
30	50	+0.0008	+0.0004	+0.0002	+0.0002	+0.0003	+0.0002	+0.0002
50	80	+0.0010	+0.0004	+0.0002	+0.0002	+0.0003	+0.0002	+0.0002
80	120	+0.0012	+0.0005	+0.0002	+0.0002	+0.0004	+0.0002	+0.0002
120	180	+0.0014	+0.0007	+0.0003	+0.0002	+0.0004	+0.0002	+0.0003
180	250	+0.0020	+0.0008	+0.0004	+0.0003	+0.0004	+0.0003	+0.0003
250	315	+0.0024	+0.0010	+0.0005	+0.0004	+0.0005	+0.0003	+0.0004
315	400	+0.0028	+0.0012	+0.0006	+0.0005	+0.0006	+0.0004	+0.0006
400	500	+0.0028	+0.0014	+0.0007	+0.0006	+0.0007	+0.0005	+0.0007
500	630	+0.0033	+0.0016	+0.0008	--	+0.0009	--	--
630	800	+0.0039	+0.0018	+0.0009	--	+0.0011	--	--

Table 10.20 — Tolerances for Outer Ring Running Accuracy of Metric Tapered Bearings

Units: inch

Nominal Outside Diameter D (mm)		K _{ea}				S _D		S _{ea}
		Class N Class 6X	Class 6	Class 5	Class 4	Class 5	Class 4	Class 4
over	incl	max	max	max	max	max	max	max
18	30	+0.0007	+0.0004	+0.0002	+0.0002	+0.0003	+0.0002	+0.0002
30	50	+0.0008	+0.0004	+0.0003	+0.0002	+0.0003	+0.0002	+0.0002
50	80	+0.0010	+0.0005	+0.0003	+0.0002	+0.0003	+0.0002	+0.0002
80	120	+0.0014	+0.0007	+0.0004	+0.0002	+0.0004	+0.0002	+0.0002
120	150	+0.0016	+0.0008	+0.0004	+0.0003	+0.0004	+0.0002	+0.0003
150	180	+0.0018	+0.0009	+0.0005	+0.0003	+0.0004	+0.0002	+0.0003
180	250	+0.0020	+0.0010	+0.0006	+0.0004	+0.0004	+0.0003	+0.0004
250	315	+0.0024	+0.0012	+0.0007	+0.0004	+0.0005	+0.0003	+0.0004
315	400	+0.0028	+0.0014	+0.0008	+0.0005	+0.0005	+0.0004	+0.0005
400	500	+0.0031	+0.0016	+0.0009	+0.0006	+0.0006	+0.0004	+0.0006
500	630	+0.0039	+0.0020	+0.0010	+0.0007	+0.0007	+0.0005	+0.0007
630	800	+0.0047	+0.0024	+0.0012	--	+0.0008	--	--
800	1000	+0.0047	+0.0030	+0.0014	--	+0.0009	--	--

Introduction

Ball Bearings

Cylindrical Roller Bearings

Spherical Roller Bearings

Tapered Roller Bearings

Thrust Bearings

Split Pillow Blocks

Super Precision Bearings

Linear Motion

Rolling Mill Bearings

Engineering Section

Table 10.21 — Tolerances for Cone Width, Cup Width, and Combined Cone/Cup Width of Metric Tapered Roller Bearings



Units: inch

Nominal Bore Diameter <i>d</i> (mm)		ΔB_s						ΔC_s						ΔT_s					
		Class N Class 6		Class 6X		Class 5 Class 4		Class N Class 6		Class 6X		Class 5 Class 4		Class N Class 6		Class 6X		Class 5 Class 4	
over	incl	high	low	high	low	high	low	high	low	high	low	high	low	high	low	high	low	high	low
10	18	0	-0.0047	0	-0.0020	0	-0.0079	0	-0.0047	0	-0.0039	0	-0.0079	-0.0079	0	+0.0039	0	+0.0079	-0.0079
18	30	0	-0.0047	0	-0.0020	0	-0.0079	0	-0.0047	0	-0.0039	0	-0.0079	-0.0079	0	+0.0039	0	+0.0079	-0.0079
30	50	0	-0.0047	0	-0.0020	0	-0.0094	0	-0.0047	0	-0.0039	0	-0.0094	-0.0079	0	+0.0039	0	+0.0079	-0.0079
50	80	0	-0.0059	0	-0.0020	0	-0.0118	0	-0.0059	0	-0.0039	0	-0.0118	-0.0079	0	+0.0039	0	+0.0079	-0.0079
80	120	0	-0.0079	0	-0.0020	0	-0.0157	0	-0.0079	0	-0.0039	0	-0.0157	+0.0079	-0.0079	+0.0039	0	+0.0079	-0.0079
120	180	0	-0.0098	0	-0.0020	0	-0.0197	0	-0.0098	0	-0.0039	0	-0.0197	+0.0138	-0.0098	+0.0059	0	+0.0138	-0.0098
180	250	0	-0.0118	0	-0.0020	0	-0.0197	0	-0.0118	0	-0.0039	0	-0.0197	+0.0138	-0.0098	+0.0059	0	+0.0209	-0.0098
250	315	0	-0.0138	0	-0.0020	0	-0.0276	0	-0.0138	0	-0.0039	0	-0.0276	+0.0138	-0.0098	+0.0079	0	+0.0209	-0.0098
315	400	0	-0.0157	0	-0.0020	0	-0.0315	0	-0.0157	0	-0.0039	0	-0.0315	+0.0157	-0.0157	+0.0079	0	+0.0157	-0.0157
400	500	0	-0.0177	-	-	0	-0.0315	0	-0.0177	-	-	0	-0.0315	+0.0157	-0.0157	-	-	+0.0157	-0.0157
500	630	0	-0.0197	-	-	0	-0.0315	0	-0.0197	-	-	0	-0.0315	+0.0197	-0.0197	-	-	+0.0197	-0.0197
630	800	0	-0.0295	-	-	0	-0.0315	0	-0.0295	-	-	0	-0.0315	+0.0236	-0.0236	-	-	+0.0236	-0.0236

Remarks: 1. The effective width of a cone with rollers T1 is defined as the overall bearing width of a cone with rollers combined with a master cup.
 2. The effective width of a cup T2 is defined as the overall bearing width of a cup combined with a master cone with rollers.

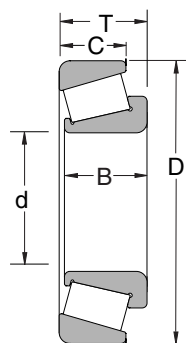

Single Row

Table 10.21 — Tolerances for Cone Width, Cup Width, and Combined Cone/Cup Width(continued)

Units: inch

Nominal Bore Diameter d (mm)		Effective Cone Width (with Rollers) Deviation ΔT_{1s}				Effective Cup Width Deviation ΔT_{2s}				Overall Combined Bearing Width Deviation			
		Class N		Class 6X		Class N		Class 6X		ΔB_{2s}		$\Delta B_{4s}, \Delta C_{4s}$	
		high	low	high	low	high	low	high	low	high	low	high	low
10	18	+0.0039	0	+0.0020	0	+0.0039	0	+0.0020	0	+0.0079	-0.0079	-	-
18	30	+0.0039	0	+0.0020	0	+0.0039	0	+0.0020	0	+0.0079	-0.0079	-	-
30	50	+0.0039	0	+0.0020	0	+0.0039	0	+0.0020	0	+0.0079	-0.0079	-	-
50	80	+0.0039	0	+0.0020	0	+0.0039	0	+0.0020	0	+0.0118	-0.0118	+0.0118	-0.0118
80	120	+0.0039	-0.0039	+0.0020	0	+0.0039	-0.0039	+0.0020	0	+0.0118	-0.0118	+0.0157	-0.0157
120	180	+0.0059	-0.0059	+0.0020	0	+0.0079	-0.0039	+0.0039	0	+0.0157	-0.0157	+0.0197	-0.0197
180	250	+0.0059	-0.0059	+0.0020	0	+0.0079	-0.0039	+0.0039	0	+0.0177	-0.0177	+0.0236	-0.0236
250	315	+0.0059	-0.0059	+0.0039	0	+0.0079	-0.0039	+0.0039	0	+0.0217	-0.0217	+0.0276	-0.0276
315	400	+0.0079	-0.0079	+0.0039	0	+0.0079	-0.0079	+0.0039	0	+0.0236	-0.0236	+0.0315	-0.0315
400	500	-	-	-	-	-	-	-	-	+0.0276	-0.0276	+0.0354	-0.0354
500	630	-	-	-	-	-	-	-	-	+0.0315	-0.0315	+0.0394	-0.0394
630	800	-	-	-	-	-	-	-	-	+0.0472	-0.0472	+0.0591	-0.0591

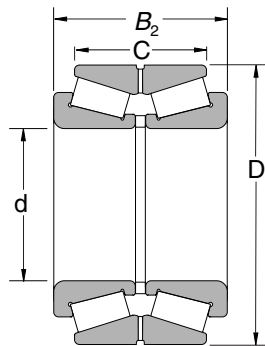

KBE Type

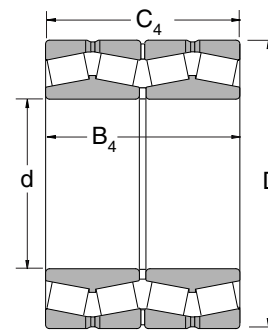

KV Type

Introduction

Ball Bearings

Cylindrical Roller Bearings

Spherical Roller Bearings

Tapered Roller Bearings

Thrust Bearings

Split Pillow Blocks

Super Precision Bearings

Linear Motion

Rolling Mill Bearings

Engineering Section

321

Table 10.22 —Tolerances for Outer Ring Outside Diameter and Radial Runout of Inch Tapered Roller Bearings



Units: inch

Nominal Outside Diameter <i>D</i> (in)		ΔD_s					
		Class 4,2		Class 3,0		Class 00	
over	incl.	high	low	high	low	high	low
10.5000	12.0000	+0.010	0	+0.0005	0	+0.0003	0
12.0000	24.0000	+0.010	0	+0.0005	0	—	—
24.0000	36.0000	+0.020	0	+0.0010	0	—	—
36.0000	48.0000	+0.030	0	+0.0015	0	—	—
		+0.040	0	+0.0020	0	—	—
		+0.050	0	+0.0030	0	—	—

Table 10.23 — Tolerances for Overall Width and Combined Width of Inch Tapered Roller Bearings



Units: inch

Nominal Bore Diameter <i>d</i> (in)		ΔT_s									
		Class 4		Class 2		Class 3,0				Class 0 Class 00	
						$D \leq 508.000\text{mm}$		$D > 508.000\text{mm}$			
over	incl.	high	low	high	low	high	low	high	low	high	low
4.0000	12.0000	+0.0080	—	+0.0080	—	+0.0080	-0.0080	+0.0080	-0.0080	+0.0080	-0.0080
12.0000	24.0000	+0.0140	-0.0100	+0.0080	—	+0.0080	-0.0080	+0.0080	-0.0080	+0.0080	-0.0080
24.0000		+0.0150	-0.0150	+0.0150	-0.0150	+0.0080	-0.0080	+0.0150	-0.0150	—	—
		+0.0150	-0.0150	—	—	+0.0150	-0.0150	+0.0150	-0.0150	—	—

Table 10.24 — Tolerances for Inner Ring Bore of Inch Design Tapered Roller Bearings

Units: inch

Nominal Bore Diameter <i>d</i> (in)		Δd_s					
		Class 4,2		Class 3,0		Class 00	
over	incl.	high	low	high	low	high	low
3.0000	10.5000	+0.0005	0	+0.0005	0	+0.0003	0
10.5000	12.0000	+0.0010	0	+0.0005	0	+0.0003	0
12.0000	24.0000	+0.0010	0	+0.0005	0	—	—
24.0000	36.0000	+0.0020	0	+0.0010	0	—	—
36.0000	48.0000	+0.0030	0	+0.0015	0	—	—
48.0000		+0.0040	0	+0.0020	0	—	—
		+0.0050	0	+0.0030	0	—	—

Introduction
Ball Bearings
Cylindrical Roller Bearings
Spherical Roller Bearings
Tapered Roller Bearings
Thrust Bearings
Split Pillow Blocks
Super Precision Bearings
Linear Motion
Rolling Mill Bearings
Engineering Section

Table 10.22 —Tolerances for Outer Ring Outside Diameter and Radial Runout of Inch Tapered Roller Bearings (continued)

Units: inch

K_{ia}, K_{ea}				
Class 4	Class 2	Class 3	Class 0	Class 00
max	max	max	max	max
.0020	.0015	.0003	.0002	.0001
.0020	.0015	.0003	.0002	—
.0020	.0015	.0003	—	—
.0030	.0020	.0020	—	—
.0030	—	.0030	—	—
.0030	—	.0030	—	—

Table 10.23 —Tolerances for Overall Width and Combined Width of Inch Tapered Roller Bearings (continued)

Units: inch

Double-Row Bearings (KBE Type) ΔB_{2s}										Four-Row Bearings (KV Type) $\Delta B_{4s}, \Delta C_{4s}$	
Class 4		Class 2		Class 3,0				Class 0,00		Class 4,3,0	
				$D \leq 508.000\text{mm}$		$>508.000\text{mm}$					
high	low	high	low	high	low	high	low	high	low	high	low
+.0160	0	+.0160	0	+.0160	-.0160	+.0160	-.0160	+.0160	-.0160	+.0600	-.0600
+.0280	-.0200	+.0160	-.0080	+.0160	-.0160	+.0160	-.0160	+.0160	-.0160	+.0600	-.0600
+.0300	-.0300	+.0300	-.0300	+.0160	-.0160	+.0308	-.0308	—	—	+.0600	-.0600
+.0300	-.0300	—	—	+.0300	-.0300	+.0308	-.0308	—	—	+.0600	-.0600

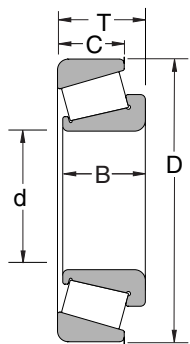

Single Row

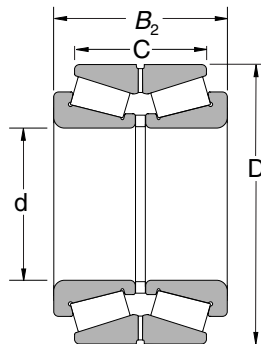

KBE Type

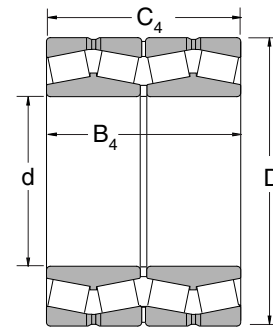

KV Type

Table 10.25 —Tolerances for Shaft Washer Bore Diameter and Running Accuracy of Thrust Ball Bearings

Units: inch

Nominal Bore Diameter d or d ₂ (mm)		Δd_{mp} or Δd_{2mp}				V_{dp} or V_{d2p}		S_i or $S_e^{(1)}$			
		Class N,6,5		Class 4			Class 4	Class N	Class 6	Class 5	Class 4
over	incl	high	low	high	low	max	max	max	max	max	max
18	18	0	-0.0003	0	-0.0003	.0002	.0002	.0004	.0002	.0001	.0001
30	30	0	-0.0004	0	-0.0003	.0003	.0002	.0004	.0002	.0001	.0001
50	50	0	-0.0005	0	-0.0004	.0004	.0003	.0004	.0002	.0001	.0001
80	80	0	-0.0006	0	-0.0005	.0004	.0004	.0004	.0003	.0002	.0001
120	120	0	-0.0008	0	-0.0006	.0006	.0004	.0006	.0003	.0002	.0001
180	180	0	-0.0010	0	-0.0007	.0007	.0006	.0006	.0004	.0002	.0002
250	250	0	-0.0012	0	-0.0009	.0009	.0007	.0008	.0004	.0002	.0002
315	315	0	-0.0014	0	-0.0010	.0010	.0007	.0010	.0005	.0003	.0002
400	400	0	-0.0016	0	-0.0012	.0012	.0009	.0012	.0006	.0003	.0002
500	500	0	-0.0018	0	-0.0014	.0013	.0010	.0012	.0007	.0004	.0002
630	630	0	-0.0020	0	-0.0016	.0015	.0012	.0014	.0008	.0004	.0003
800	800	0	-0.0030	0	-0.0020	—	—	.0016	.0010	.0005	.0003
1000	1000	0	-0.0039	—	—	—	—	.0018	.0012	.0006	—
1250	1250	0	-0.0049	—	—	—	—	.0020	.0014	.0007	—

Note: 1) For double-direction bearings, the thickness variation doesn't depend on the bore diameter d_2 , but on d for single-direction bearings with the same D in the same diameter series.
 Remarks: The thickness variation of housing washers, S_e , applies only to flat-seat thrust bearings

Table 10.26 —Tolerances for Outside Diameter of Housing Washers and Aligning Seat Washers of Thrust Ball Bearings

Units: inch

Nominal Outside Diameter of Bearing or Aligning Seat Washer D or D ₃ (mm)		ΔD_{mp}						V_{Dp}		Aligning Seat Washer Outside Diameter Deviation ΔD_{3s}	
		Flat Seat Type				Aligning Seat Washer Type		Class N,6,5	Class 4		
		Class N,6,5		Class 4		Class N,6				Class N,6	
over	incl	high	low	high	low	high	low	max	max	high	low
10	18	0	-0.0004	0	-0.0003	0	-0.0007	+0.0003	+0.0002	0	-0.0010
18	30	0	-0.0005	0	-0.0003	0	-0.0008	+0.0004	+0.0002	0	-0.0012
30	50	0	-0.0006	0	-0.0004	0	-0.0009	+0.0005	+0.0003	0	-0.0014
50	80	0	-0.0007	0	-0.0004	0	-0.0011	+0.0006	+0.0003	0	-0.0018
80	120	0	-0.0009	0	-0.0005	0	-0.0013	+0.0007	+0.0004	0	-0.0024
120	180	0	-0.0010	0	-0.0006	0	-0.0015	+0.0007	+0.0004	0	-0.0030
180	250	0	-0.0012	0	-0.0008	0	-0.0018	+0.0009	+0.0006	0	-0.0035
250	315	0	-0.0014	0	-0.0010	0	-0.0021	+0.0010	+0.0007	0	-0.0041
315	400	0	-0.0016	0	-0.0011	0	-0.0024	+0.0012	+0.0008	0	-0.0047
400	500	0	-0.0018	0	-0.0013	0	-0.0027	+0.0013	+0.0010	0	-0.0053
500	630	0	-0.0020	0	-0.0015	0	-0.0030	+0.0015	+0.0011	0	-0.0071
630	800	0	-0.0030	0	-0.0018	0	-0.0044	+0.0022	+0.0013	0	-0.0089
800	1000	0	-0.0039	—	—	—	—	+0.0030	—	—	—
1000	1250	0	-0.0049	—	—	—	—	—	—	—	—
1250	1600	0	-0.0063	—	—	—	—	—	—	—	—

Introduction
 Ball Bearings
 Cylindrical Roller Bearings
 Spherical Roller Bearings
 Tapered Roller Bearings
 Thrust Bearings
 Split Pillow Blocks
 Super Precision Bearings
 Linear Motion
 Rolling Mill Bearings
 Engineering Section

Table 10.27 —Tolerances for Thrust Ball Bearing Height and Central Washer Height

Units: inch

Nominal Bore Diameter d (mm)		Flat Seat Type				Aligning Seat Washer Type				With Aligning Seat Washer				Height Deviation of Central Washer ΔB_s	
		ΔT_s or ΔT_{2s}		ΔT_{1s}		ΔT_{3s} or ΔT_{5s}		ΔT_{5s}		ΔT_{4s} or ΔT_{8s}		ΔT_{1s}			
		Class N,6,5,4		Class N,6,5,4		Class N,6		Class N,6		Class N,6		Class N,6		Class N,6,5,4	
over	incl	high	low	high	low	high	low	high	low	high	low	high	low	high	low
30	30	+0	-0.0030	+0.0020	-0.0059	+0	-0.0030	+0.0020	-0.0059	+0.0020	-0.0030	+0.0059	-0.0059	+0	-0.0020
50	50	+0	-0.0039	+0.0030	-0.0079	+0	-0.0039	+0.0030	-0.0079	+0.0020	-0.0039	+0.0069	-0.0079	+0	-0.0030
80	80	+0	-0.0049	+0.0039	-0.0098	+0	-0.0049	+0.0039	-0.0098	+0.0030	-0.0049	+0.0098	-0.0098	+0	-0.0039
120	120	+0	-0.0059	+0.0049	-0.0118	+0	-0.0059	+0.0049	-0.0118	+0.0030	-0.0059	+0.0108	-0.0118	+0	-0.0049
180	180	+0	-0.0069	+0.0059	-0.0138	+0	-0.0069	+0.0059	-0.0138	+0.0039	-0.0069	+0.0138	-0.0138	+0	-0.0059
250	250	+0	-0.0079	+0.0069	-0.0157	+0	-0.0079	+0.0069	-0.0157	+0.0039	-0.0079	+0.0148	-0.0157	+0	-0.0069
315	315	+0	-0.0089	+0.0079	-0.0177	+0	-0.0089	+0.0079	-0.0177	+0.0049	-0.0089	+0.0177	-0.0177	+0	-0.0079
315	400	+0	-0.0118	+0.0098	-0.0236	+0	-0.0118	+0.0098	-0.0236	+0.0059	-0.0108	+0.0217	-0.0217	+0	-0.0098

Note: 1) For double-direction bearings, the thickness variation doesn't depend on the bore diameter d_2 , but on d for single-direction bearings with the same D in the same diameter series.

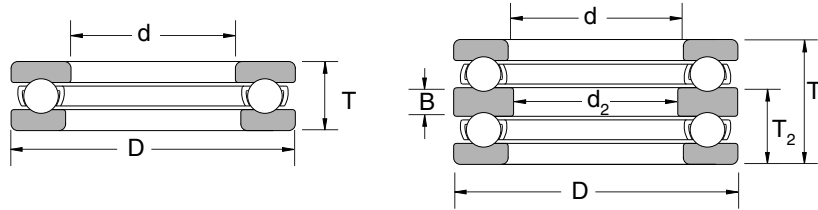

Introduction

Ball Bearings

Cylindrical Roller Bearings

Spherical Roller Bearings

Tapered Roller Bearings

Thrust Bearings

Split Pillow Blocks

Super Precision Bearings

Linear Motion

Rolling Mill Bearings

Engineering Section

Table 10.28 —Tolerances for Bore Diameters of Inner Rings and Height (Class N) of Spherical Thrust Roller Bearings

Units: inch

Nominal Bore Diameter d (mm)		Δd_{mp}		V_{dp}	Reference		
					S_d	ΔT_s	
over	incl	high	low	max	high	low	
50	80	0	-.0006	.0004	.0010	+.0059	-.0059
80	120	0	-.0008	.0006	.0010	+.0079	-.0079
120	180	0	-.0010	.0007	.0012	+.0098	-.0098
180	250	0	-.0012	.0009	.0012	+.0118	-.0118
250	315	0	-.0014	.0010	.0014	+.0138	-.0138
315	400	0	-.0016	.0012	.0016	+.0157	-.0157
400	500	0	-.0018	.0013	.0018	+.0177	-.0177

Table 10.29 —Tolerances for Outer Ring Diameter (Class N) of Spherical Thrust Roller Bearings

Units: inch

Nominal Outside Diameter D (mm)		ΔD_{mp}	
		high	low
over	incl	high	low
120	180	0	-.0010
180	250	0	-.0012
250	315	0	-.0014
315	400	0	-.0016
400	500	0	-.0018
500	630	0	-.0020
630	800	0	-.0030
800	1000	0	-.0039

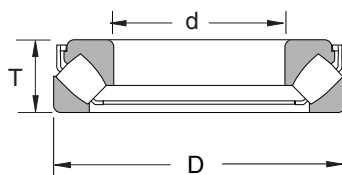

Introduction
Ball Bearings
Cylindrical Roller Bearings
Spherical Roller Bearings
Tapered Roller Bearings
Thrust Bearings
Split Pillow Blocks
Super Precision Bearings
Linear Motion
Rolling Mill Bearings
Engineering Section

Bearing Fits & Internal Clearance

Fit--Why It's Important

When a bearing's inner ring is fitted to the shaft with only slight interference, slipping or "creep" may occur. Creep may also occur between the outer ring and housing.

When creep occurs the fitted surfaces become abraded which causes excessive wear and may cause considerable damage to the shaft or housing. In addition, abrasive metal particles resulting from creep may enter the interior of the bearing and cause abnormal heating and vibration.

It is important to prevent creep by having sufficient interference to firmly secure the bearing ring to either the shaft or housing.

In specific applications, fits can be made without interference. For example, it is usually not necessary to provide fit interference for rings subjected only to stationary loads. In other applications, loose fits may be used to accommodate certain operating conditions or to facilitate bearing mounting and dismounting. In these cases, lubrication or other methods need to be considered to prevent damage to the fitting surfaces due to creep.

Table 10.30 —Loading Conditions and Fit

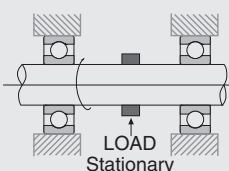
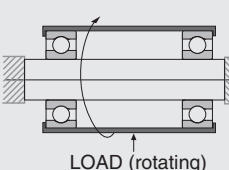
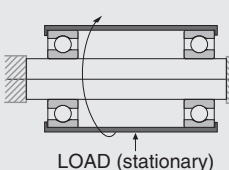
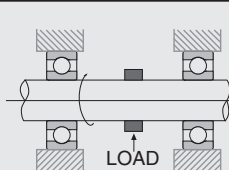
Load Application	Bearing Operation		Loading Conditions	Fit	
	Inner Ring	Outer Ring		Inner Ring and Shaft	Outer Ring and Housing
	Rotating	Stationary	Rotating Inner Ring Load	Tight Fit	Loose Fit
	Stationary	Rotating	Stationary Outer Ring Load		
	Stationary	Rotating	Rotating Outer Ring Load	Loose Fit	Tight Fit
	Rotating	Stationary	Stationary Inner Ring Load		
Direction of Load Indeterminate	Rotating or Stationary	Rotating or Stationary	-	Tight Fit	Tight Fit

How To Select Proper Fit

Load Conditions and Fit

Proper fit may be selected from Table 10.30 on page 327 based on the load and operating conditions.

Magnitude of Load and Interference

Under load, a slight amount of deflection or deformation of the bearing rings will occur. This reduces the interference fit. For this reason, heavier loaded bearings require a heavier initial interference fit. The required interference can be calculated using the following equations:

$$\Delta d_f = 0.08 \sqrt{\frac{d}{B} F_r} \times 10^{-3}$$

light and normal loads

$$\Delta d_e \geq 0.02 \frac{F_r}{B} \times 10^{-3}$$

when $F_r > .20 C_{or}$

Where Δd_f : Interference decrease of inner ring (mm)
 Δd_e : Effective interference (mm)
 d : Bearing bore diameter (mm)
 B : Inner ring width (mm)
 F_r : Radial load applied to bearing (N)

Interference Variation Due to Temperature Difference Between Bearing and Shaft or Housing

Interference decreases when bearing temperature increases during operation. If the temperature difference between the interior of the bearing and the surrounding parts of the housing is $\Delta T(^{\circ}\text{C})$, then the temperature difference between the fitted surfaces of the shaft and the inner ring is estimated to be about $(0.1 \sim 0.15)T$. Decrease of inner ring interference due to this difference may be calculated from the following equation: $\Delta d_T = (0.10 \sim 0.15)\Delta T \cdot \alpha \cdot d = 0.0015\Delta T \cdot d \times 10^{-3}$

Where Δd_T = Decrease of interference of inner ring due to temperature increase (mm)
 ΔT = Temperature difference between bearing and surrounding parts
 α = Coefficient of linear expansion of bearing steel ($12.5 \times 10^{-6}(1/^{\circ}\text{C})$)
 d = bore diameter

Table 10.31 — Fits of Radial Bearings with Solid Steel Shafts

Load Conditions	Examples	Shaft Diameter (mm)			Tolerance of Shaft		
		Ball Bearings	Cylindrical or Tapered Roller Brgs.	Spherical Roller Bearings			
Radial Bearings with Cylindrical Bores							
Rotating Outer Ring Load	Easy axial displacement of inner ring on shaft desirable	Wheels on Stationary axles			g6		
	Easy axial displacement of inner ring on shaft unnecessary	Tension Pulleys, Rope Sheaves			h6		
Rotating Inner Ring Load or Direction of Load Indeterminate	Light Load ($<0.06C_r^{(1)}$)	Electrical Appliances, Pumps, Blowers, Transport Vehicles, Precision Machinery, Machine Tools	<18	–	–	js5	
			18 to 100	<40	–	js6 (j6)	
			100 to 200	40 to 140	–	K6	
			–	140 to 200	–	m6	
	Normal Loads (0.06 to 0.13 $C_r^{(1)}$)	General Bearing Applications, Medium and Large Motors, Turbines, Pumps, Engine Main Bearings, Gears, Woodworking Machines		<18	–	–	js5-6(j5-6)
				18 to 100	<40	<40	k5 or 6
				100 to 140	40 to 100	40 to 65	m5 or 6
				140 to 200	100 to 140	65 to 100	m6
				200 to 280	140 to 200	100 to 140	n6
				–	200 to 400	140 to 280	p6
				–	–	280 to 500	r6
				–	–	>500	r7
	Heavy Loads ($>0.13C_r^{(1)}$)	Railway Axle boxes, Industrial Vehicles, Traction Motors, Construction Equipment, Crushers		–	50 to 140	50 to 100	n6
				–	140 to 200	100 to 140	p6
			–	over 200	140 to 200	r6	
			–	–	200 to 500	r7	
Axial Loads Only	–	All Shaft Diameters			js6 (j6)		
Radial Bearings with Tapered Bores and Sleeves (Contact NSK Engineering)							

Note:1. C_r represents the basic load rating of the bearing

Table 10.32 — Fits of Thrust Bearings with Solid Steel Shafts

For more information, see page 356

Load Conditions		Examples	Shaft Diameter (mm)	Tolerance of Shaft
Central Axial Load Only		Main Shafts of Lathes	All Shaft Diameters	h6 or js6 (j6)
Combined Radial and Axial Loads (Spherical Thrust Roller Bearings)	Stationary Inner Ring Load	Cone Crushers	All Shaft Diameters	js6(j6)
	Rotating Inner Ring Load or Direction of Load Indeterminate	Paper Pulp Refiners, Plastic Extruders	<200	k6
			200 to 400	m6
			Over 400	n6

Table 10.33 — Fits of Radial Bearings with Housings

For more information, see page 358

Load Conditions			Examples	Tolerances for Housing Bores
Solid Housings	Rotating Outer Ring Load	Heavy Loads on Bearing in Thin-Walled Housing or Heavy Shock Loads	Automotive Wheel Hubs (Roller Bearings) Crane Traveling Wheels	P7
		Normal or Heavy Loads	Automotive Wheel Hubs (Ball Bearings) Vibrating Screens	N7
		Light or Variable Loads	Conveyor Roller, Rope Sheaves, Tension Pulleys	M7
	Direction of Load Indeterminate	Heavy Shock Loads	Traction Motors	M7
		Normal or Heavy Loads	Pumps, Crankshaft Main Bearings, Medium and Large Motors	K7
		Normal or Light Loads		JS7 (J7)
Solid or Split Housings	Rotating Inner Ring Load	Loads of All Kinds	General Bearing Applications, Railway Axleboxes	H7
		Normal and Light Loads	Plummer Blocks	H8
		High Temperature Rise of Inner Ring Through Shaft	Paper Dryers	G7
		Accurate Running Desirable Under Normal and Light Loads	Grinding Spindle Rear Ball Bearings, High Speed Centrifugal Compressor Free Bearings	JS6(J6)
Solid Housings	Direction of Load Indeterminate	Accurate Running Desirable Under Normal and Light Loads	Grinding Spindle Front Ball Bearings, High Speed Centrifugal Compressor Fixed Bearings	K6
			Rotating Inner Ring Load	Accurate Running at High Rigidity Desirable under Variable Loads
			Minimum noise is required	Electrical Home Appliances

Table 10.34 — Fits of Thrust Bearings with Housings

For more information, see page 358

Load Conditions		Remarks	Tolerances for Housing Bores	
Axial Loads Only	Thrust Ball Bearings	General Purpose Application	Clearance over 0.25mm	
		When Precision is Required	H8	
	Spherical Thrust Roller Bearings	When Radial Loads are Sustained by Other Bearings	Outer ring has radial clearance	
Combined Radial and Axial Loads	Stationary Outer Ring Loads	Spherical Thrust Roller Bearings	-	
	Rotating Outer Ring Loads or Direction of Load Indeterminate		Normal Loads	K7
			Relatively Heavy Radial Loads	M7

Introduction

Ball Bearings

Cylindrical Roller Bearings

Spherical Roller Bearings

Tapered Roller Bearings

Thrust Bearings

Split Pillow Blocks

Super Precision Bearings

Linear Motion

Rolling Mill Bearings

Engineering Section

Bearing Internal Clearance

Internal Clearances and Standards

Bearing internal clearance is the total clearance between the rings and rolling elements. Internal clearance influences fatigue life, vibration, noise, and operating temperature. Therefore, selection of the proper clearance is critical.

Radial and axial clearances are defined as the total amount that one ring can be displaced relative to the other in either the radial or axial direction as shown in this drawing.

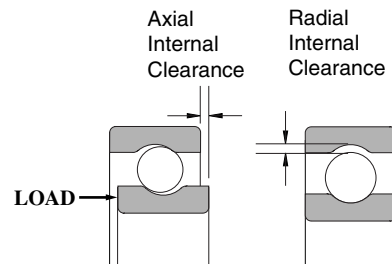

To obtain accurate measurements for ball bearings, internal clearance is usually measured by applying a specified measuring load to the bearings. The clearance measured is always slightly larger than the actual bearing internal clearance due to the elastic deformation caused by the measuring load.

Actual internal clearance is obtained by correcting the measured clearance by the amount of elastic deformation. In the case of roller bearings this elastic deformation is negligible.

Bearing internal clearances listed throughout this catalog have been corrected to provide actual internal clearances.

Radial Internal Clearance

Radial Internal Clearances for several types of ball bearings and roller bearings are presented in the following tables:

Table 10.35 — Radial Internal Clearance in Single Row Deep Groove Ball Bearings Under No Load

Units: inch

Nominal Bore Diameter d (mm)		Radial Internal Clearance							
		C2		C0		C3		C4	
over	incl	low	high	low	high	low	high	low	high
(10mm Only)*		+0.000	+0.003	+0.001	+0.005	+0.003	+0.009	+0.006	+0.011
10	18	+0.000	+0.004	+0.001	+0.007	+0.004	+0.010	+0.007	+0.013
18	24	+0.000	+0.004	+0.002	+0.008	+0.005	+0.011	+0.008	+0.014
24	30	+0.000	+0.004	+0.002	+0.008	+0.005	+0.011	+0.009	+0.016
30	40	+0.000	+0.004	+0.002	+0.008	+0.006	+0.013	+0.011	+0.018
40	50	+0.000	+0.004	+0.002	+0.009	+0.007	+0.014	+0.012	+0.020
50	65	+0.000	+0.006	+0.003	+0.011	+0.009	+0.017	+0.015	+0.024
65	80	+0.000	+0.006	+0.004	+0.012	+0.010	+0.020	+0.018	+0.028
80	100	+0.000	+0.007	+0.005	+0.014	+0.012	+0.023	+0.021	+0.033
100	120	+0.001	+0.008	+0.006	+0.016	+0.014	+0.026	+0.024	+0.038
120	140	+0.001	+0.009	+0.007	+0.019	+0.016	+0.032	+0.028	+0.045
140	160	+0.001	+0.009	+0.007	+0.021	+0.018	+0.036	+0.032	+0.051
160	180	+0.001	+0.010	+0.008	+0.024	+0.021	+0.040	+0.036	+0.058
180	200	+0.001	+0.012	+0.010	+0.028	+0.025	+0.046	+0.042	+0.064
200	225	—	+0.013	+0.010	+0.0315	+0.029	+0.053	+0.049	+0.074
225	250	—	+0.014	+0.012	+0.035	+0.033	+0.059	+0.057	+0.084
250	280	—	+0.016	+0.014	+0.037	+0.035	+0.063	+0.061	+0.092
280	315	—	+0.020	+0.020	+0.043	+0.043	+0.071	+0.075	+0.104
315	355	—	+0.022	+0.022	+0.049	+0.049	+0.079	+0.085	+0.116
355	400	—	+0.026	+0.026	+0.055	+0.055	+0.089	+0.096	+0.134

*For bore sizes smaller than 10mm, refer to Table 10.36

Table 10.36 — Radial Internal Clearances in Extra Small & Miniature Ball Bearings Under No Load

Units: inch

Clearance Symbols (Among these NSK Standard Clearances, MC5 is the most widely used)											
MC1		MC2		MC3		MC4		MC5		MC6	
low	high	low	high	low	high	low	high	low	high	low	high
+0	+0.002	+0.001	+0.003	+0.002	+0.004	+0.003	+0.005	+0.005	+0.008	+0.008	+0.011

Table 10.37 — Radial Internal Clearances in Cylindrical Roller Bearings with Cylindrical Bores

Units: μm

Nominal Bore Dia. $d(\text{mm})$		Clearances in Interchangeable Bearings with Cylindrical Bores										Clearances in Matched Bearings with Cylindrical Bores											
		C2		C0		C3		C4		C5		CC1		CC2		CC(1)		CC3		CC4		CC5	
		over	incl	min	max	min	max	min	max	min	max	min	max	min	max	min	max	min	max	min	max	min	max
0	10	.0000	.0010	.0008	.0018	.0014	.0024	.0020	.0030	-	-	-	-	-	-	-	-	-	-	-	-	-	
10	24	.0000	.0010	.0008	.0018	.0014	.0024	.0020	.0030	.0026	.0035	.0002	.0006	.0004	.0008	.0008	.0012	.0014	.0018	.0018	.0022	.0026	.0030
24	30	.0000	.0010	.0008	.0018	.0014	.0024	.0020	.0030	.0028	.0037	.0002	.0006	.0004	.0010	.0010	.0014	.0016	.0020	.0020	.0024	.0028	.0031
30	40	.0002	.0012	.0010	.0020	.0018	.0028	.0024	.0033	.0031	.0041	.0002	.0006	.0005	.0010	.0010	.0016	.0018	.0022	.0022	.0028	.0031	.0037
40	50	.0002	.0014	.0012	.0024	.0020	.0031	.0028	.0039	.0037	.0049	.0002	.0007	.0006	.0012	.0012	.0018	.0020	.0026	.0026	.0031	.0037	.0043
50	65	.0004	.0016	.0016	.0028	.0024	.0035	.0031	.0043	.0039	.0055	.0002	.0008	.0006	.0014	.0014	.0020	.0022	.0030	.0030	.0035	.0043	.0051
65	80	.0004	.0018	.0016	.0030	.0026	.0039	.0035	.0049	.0051	.0065	.0004	.0010	.0008	.0016	.0016	.0024	.0028	.0035	.0035	.0043	.0051	.0059
80	100	.0006	.0020	.0020	.0033	.0030	.0043	.0041	.0055	.0061	.0075	.0004	.0012	.0010	.0018	.0018	.0028	.0031	.0041	.0041	.0049	.0061	.0071
100	120	.0006	.0022	.0020	.0035	.0033	.0049	.0049	.0065	.0071	.0087	.0004	.0012	.0010	.0020	.0020	.0031	.0037	.0047	.0047	.0057	.0071	.0081
120	140	.0006	.0024	.0024	.0041	.0039	.0057	.0057	.0075	.0079	.0096	.0004	.0014	.0012	.0024	.0024	.0035	.0041	.0053	.0053	.0063	.0079	.0091
140	160	.0008	.0028	.0028	.0047	.0045	.0065	.0065	.0085	.0089	.0108	.0004	.0014	.0014	.0026	.0026	.0039	.0045	.0059	.0059	.0071	.0089	.0102
160	180	.0010	.0030	.0030	.0049	.0047	.0067	.0067	.0087	.0098	.0118	.0004	.0016	.0014	.0030	.0030	.0043	.0049	.0065	.0065	.0079	.0098	.0112
180	200	.0014	.0035	.0035	.0057	.0055	.0077	.0077	.0098	.0108	.0130	.0006	.0018	.0016	.0031	.0031	.0047	.0055	.0071	.0071	.0087	.0108	.0124
200	225	.0018	.0041	.0041	.0065	.0063	.0087	.0087	.0110	.0120	.0144	.0006	.0020	.0018	.0035	.0035	.0053	.0061	.0079	.0079	.0094	.0120	.0138
225	250	.0018	.0043	.0043	.0069	.0067	.0093	.0093	.0118	.0130	.0156	.0006	.0020	.0020	.0039	.0039	.0059	.0067	.0085	.0085	.0104	.0130	.0150
250	280	.0022	.0049	.0049	.0077	.0075	.0102	.0102	.0130	.0146	.0173	.0008	.0022	.0022	.0043	.0043	.0065	.0073	.0094	.0094	.0116	.0146	.0165
280	315	.0022	.0051	.0051	.0081	.0079	.0108	.0108	.0138	.0161	.0191	.0008	.0024	.0024	.0047	.0047	.0071	.0081	.0104	.0104	.0128	.0161	.0185
315	355	.0026	.0057	.0057	.0089	.0089	.0120	.0120	.0152	.0179	.0211	.0008	.0026	.0026	.0053	.0053	.0079	.0089	.0116	.0116	.0142	.0179	.0205
355	400	.0039	.0075	.0075	.0110	.0110	.0146	.0146	.0181	.0201	.0236	.0010	.0030	.0030	.0059	.0059	.0089	.0100	.0130	.0130	.0159	.0201	.0230
400	450	.0043	.0083	.0083	.0122	.0122	.0161	.0161	.0201	.0222	.0262	.0010	.0033	.0033	.0067	.0067	.0100	.0112	.0146	.0146	.0179	.0222	.0256
450	500	.0043	.0087	.0087	.0130	.0130	.0173	.0173	.0217	.0246	.0289	.0010	.0037	.0037	.0075	.0075	.0112	.0124	.0161	.0161	.0199	.0246	.0283

Note: (1) CC is the symbol for normal clearance for matched cylindrical roller bearings and solid-type needle roller bearings.

Table 10.38 — Radial Internal Clearances in Cylindrical Roller Bearings with Tapered Bores

Units: μm

Nominal Bore Dia. $d(\text{mm})$		Clearances in Matched Bearings with Tapered Bores													
		CC9(1)		CC1		CC2		CC(2)		CC3		CC4		CC5	
		over	incl	min	max	min	max	min	max	min	max	min	max	min	max
10	24	.0002	.0004	.0004	.0008	.0008	.0012	.0014	.0018	.0018	.0022	.0022	.0026	.0030	.0033
24	30	.0002	.0004	.0004	.0010	.0010	.0014	.0016	.0020	.0020	.0024	.0024	.0028	.0031	.0037
30	40	.0002	.0005	.0005	.0010	.0010	.0016	.0018	.0022	.0022	.0028	.0028	.0031	.0037	.0043
40	50	.0002	.0006	.0006	.0012	.0012	.0018	.0020	.0026	.0026	.0031	.0031	.0037	.0043	.0049
50	65	.0002	.0006	.0006	.0014	.0014	.0020	.0022	.0030	.0030	.0035	.0035	.0043	.0051	.0059
65	80	.0004	.0008	.0008	.0016	.0016	.0024	.0028	.0035	.0035	.0043	.0043	.0051	.0059	.0067
80	100	.0004	.0010	.0010	.0018	.0018	.0028	.0031	.0041	.0041	.0049	.0049	.0059	.0071	.0081
100	120	.0004	.0010	.0010	.0020	.0020	.0031	.0037	.0047	.0047	.0057	.0057	.0067	.0081	.0091
120	140	.0006	.0012	.0012	.0024	.0024	.0035	.0041	.0053	.0053	.0063	.0063	.0075	.0091	.0102
140	160	.0006	.0014	.0014	.0026	.0026	.0039	.0045	.0059	.0059	.0071	.0071	.0085	.0102	.0116
160	180	.0006	.0014	.0014	.0030	.0030	.0043	.0049	.0065	.0065	.0079	.0079	.0094	.0112	.0126
180	200	.0008	.0016	.0016	.0031	.0031	.0047	.0055	.0071	.0071	.0087	.0087	.0102	.0124	.0140
200	225	.0008	.0018	.0018	.0035	.0035	.0053	.0061	.0079	.0079	.0094	.0094	.0112	.0138	.0156
225	250	.0010	.0020	.0020	.0039	.0039	.0059	.0067	.0085	.0085	.0104	.0104	.0124	.0150	.0169
250	280	.0010	.0022	.0022	.0043	.0043	.0065	.0073	.0094	.0094	.0116	.0116	.0138	.0165	.0187
280	315	.0012	.0024	.0024	.0047	.0047	.0071	.0081	.0104	.0104	.0128	.0128	.0152	.0185	.0209
315	355	.0012	.0026	.0026	.0053	.0053	.0079	.0089	.0116	.0116	.0142	.0142	.0169	.0205	.0230
355	400	.0014	.0030	.0030	.0059	.0059	.0089	.0100	.0130	.0130	.0159	.0159	.0189	.0230	.0260
400	450	.0016	.0033	.0033	.0067	.0067	.0100	.0112	.0146	.0146	.0179	.0179	.0213	.0256	.0289
450	500	.0018	.0037	.0037	.0075	.0075	.0112	.0124	.0161	.0161	.0199	.0199	.0236	.0283	.0321

Notes (1) Clearance CC9 is applicable to cylindrical roller bearings with tapered bores in ISO Tolerance Classes 5 and 4.
 (2) CC is the symbol for normal clearance for matched cylindrical roller bearings and solid-type needle roller bearings.

Introduction
Ball Bearings
Cylindrical Roller Bearings
Spherical Roller Bearings
Tapered Roller Bearings
Thrust Bearings
Split Pillow Blocks
Super Precision Bearings
Linear Motion
Rolling Mill Bearings
Engineering Section

Table 10.39 — Radial Internal Clearances in Spherical Roller Bearings with Cylindrical Bores

Units: inch

Nominal Bore Diameter d (mm)		Radial Internal Clearance							
		C2		C0		C3		C4	
over	incl	low	high	low	high	low	high	low	high
24	30	+0.006	+0.010	+0.010	+0.016	+0.016	+0.022	+0.022	+0.030
30	40	+0.006	+0.012	+0.012	+0.018	+0.018	+0.024	+0.024	+0.031
40	50	+0.008	+0.014	+0.014	+0.022	+0.022	+0.030	+0.030	+0.039
50	65	+0.008	+0.016	+0.016	+0.026	+0.026	+0.035	+0.035	+0.047
65	80	+0.012	+0.020	+0.020	+0.031	+0.031	+0.043	+0.043	+0.057
80	100	+0.014	+0.024	+0.024	+0.039	+0.039	+0.053	+0.053	+0.071
100	120	+0.016	+0.030	+0.030	+0.047	+0.047	+0.063	+0.063	+0.083
120	140	+0.020	+0.037	+0.037	+0.057	+0.057	+0.075	+0.075	+0.094
140	160	+0.024	+0.043	+0.043	+0.067	+0.067	+0.087	+0.087	+0.110
160	180	+0.026	+0.047	+0.047	+0.071	+0.071	+0.094	+0.094	+0.122
180	200	+0.028	+0.051	+0.051	+0.079	+0.079	+0.102	+0.102	+0.134
200	225	+0.031	+0.055	+0.055	+0.087	+0.087	+0.114	+0.114	+0.150
225	250	+0.035	+0.059	+0.059	+0.094	+0.094	+0.126	+0.126	+0.165
250	280	+0.039	+0.067	+0.067	+0.102	+0.102	+0.138	+0.138	+0.181
280	315	+0.043	+0.075	+0.075	+0.110	+0.110	+0.146	+0.146	+0.197
315	355	+0.047	+0.079	+0.079	+0.122	+0.122	+0.161	+0.161	+0.217
355	400	+0.051	+0.087	+0.087	+0.134	+0.134	+0.177	+0.177	+0.236
400	450	+0.055	+0.094	+0.094	+0.146	+0.146	+0.197	+0.197	+0.260
450	500	+0.055	+0.102	+0.102	+0.161	+0.161	+0.217	+0.217	+0.283
500	560	+0.059	+0.110	+0.110	+0.173	+0.173	+0.236	+0.236	+0.307
560	630	+0.067	+0.122	+0.122	+0.189	+0.189	+0.256	+0.256	+0.335
630	710	+0.075	+0.138	+0.138	+0.209	+0.209	+0.276	+0.276	+0.362
710	800	+0.083	+0.154	+0.154	+0.228	+0.228	+0.303	+0.303	+0.398
800	900	+0.091	+0.169	+0.169	+0.256	+0.256	+0.339	+0.339	+0.441
900	1000	+0.102	+0.189	+0.189	+0.280	+0.280	+0.366	+0.366	+0.480

Introduction
Ball Bearings
Cylindrical Roller Bearings
Spherical Roller Bearings
Tapered Roller Bearings
Thrust Bearings
Split Pillow Blocks
Super Precision Bearings
Linear Motion
Rolling Mill Bearings
Engineering Section

Table 10.41 — Radial Internal Clearances in Spherical Roller Bearings with Tapered Bores

Units: inch

Nominal Bore Diameter d (mm)		Radial Internal Clearance							
		C2		C0		C3		C4	
over	incl	low	high	low	high	low	high	low	high
24	30	+0.008	+0.012	+0.012	+0.016	+0.016	+0.022	+0.022	+0.030
30	40	+0.010	+0.014	+0.014	+0.020	+0.020	+0.026	+0.026	+0.033
40	50	+0.012	+0.018	+0.018	+0.024	+0.024	+0.031	+0.031	+0.039
50	65	+0.016	+0.022	+0.022	+0.030	+0.030	+0.037	+0.037	+0.047
65	80	+0.020	+0.028	+0.028	+0.037	+0.037	+0.047	+0.047	+0.059
80	100	+0.022	+0.031	+0.031	+0.043	+0.043	+0.055	+0.055	+0.071
100	120	+0.026	+0.039	+0.039	+0.053	+0.053	+0.067	+0.067	+0.087
120	140	+0.031	+0.047	+0.047	+0.063	+0.063	+0.079	+0.079	+0.102
140	160	+0.035	+0.051	+0.051	+0.071	+0.071	+0.091	+0.091	+0.118
160	180	+0.039	+0.055	+0.055	+0.079	+0.079	+0.102	+0.102	+0.134
180	200	+0.043	+0.063	+0.063	+0.087	+0.087	+0.114	+0.114	+0.146
200	225	+0.047	+0.071	+0.071	+0.098	+0.098	+0.126	+0.126	+0.161
225	250	+0.055	+0.079	+0.079	+0.106	+0.106	+0.138	+0.138	+0.177
250	280	+0.059	+0.087	+0.087	+0.118	+0.118	+0.154	+0.154	+0.193
280	315	+0.067	+0.094	+0.094	+0.130	+0.130	+0.169	+0.169	+0.213
315	355	+0.075	+0.106	+0.106	+0.142	+0.142	+0.185	+0.185	+0.232
355	400	+0.083	+0.118	+0.118	+0.157	+0.157	+0.205	+0.205	+0.256
400	450	+0.091	+0.130	+0.130	+0.173	+0.173	+0.224	+0.224	+0.283
450	500	+0.102	+0.146	+0.146	+0.193	+0.193	+0.248	+0.248	+0.311
500	560	+0.114	+0.161	+0.161	+0.213	+0.213	+0.268	+0.268	+0.343
560	630	+0.126	+0.181	+0.181	+0.236	+0.236	+0.299	+0.299	+0.386
630	710	+0.138	+0.201	+0.201	+0.264	+0.264	+0.335	+0.335	+0.429
710	800	+0.154	+0.224	+0.224	+0.295	+0.295	+0.378	+0.378	+0.480
800	900	+0.173	+0.252	+0.252	+0.331	+0.331	+0.421	+0.421	+0.539
900	1000	+0.193	+0.280	+0.280	+0.366	+0.366	+0.469	+0.469	+0.598

SELECTION OF BEARING INTERNAL CLEARANCE

By way of definition, "Normal Operating Conditions" for bearings occur when the bearing load does not exceed the equivalent load ($P=0.1C$), the inner ring is tight-fitted to the shaft and operating speed is less than 50% of the limiting speed given in the bearing tables. For the replacement market the standard clearance group, **C3**, is used for "Normal Operating Conditions." However, there are six standard clearance groups, designated as **C1**, **C2**, **C0**, **C3**, **C4** and **C5**. **C1** represents minimum clearance and **C5** represents maximum clearance.

Selection of the proper bearing clearance varies with required fits, loads, speeds, and operating temperatures. Each of these will reduce the initial internal clearance a certain amount. Changes that occur in the radial clearance of roller bearings are shown in Figure 10.42.

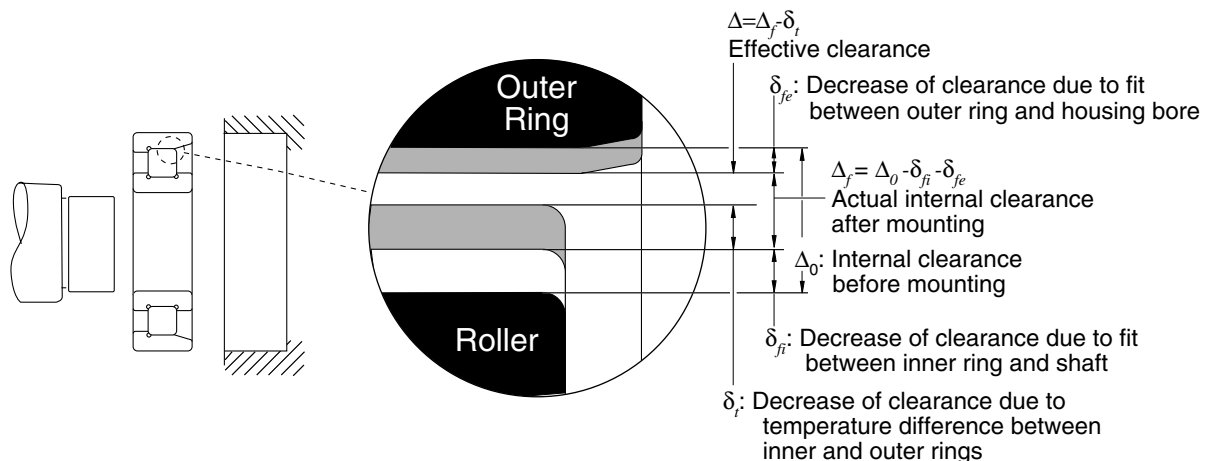

FIGURE 10.42 — CHANGES OF RADIAL INTERNAL CLEARANCE OF BEARING

CHANGES IN RADIAL INTERNAL CLEARANCE

Decrease in Radial Clearance Due to Fit

When the inner or outer ring is tight-fitted to the shaft or the housing, a decrease of radial internal clearance is caused by the expansion or contraction of the bearing rings. The decrease varies according to the bearing type, bearing size and shape, and design of the shaft or housing. The amount of decrease normally ranges from 70 to 90% of the interference.

The internal clearance after mounting is obtained by subtracting the interference decrease, Δf , from the initial internal clearance.

Temperature Effects on Radial Internal Clearance

Under normal operation, the radial internal clearance of a bearing will decrease because of the temperature differences between the inner and outer rings. Typically, the temperatures of the inner ring and the rolling elements are higher than that of the outer ring by 8 to 15°F. When the shaft is heated or when the housing is cooled, the difference between the inner and outer rings is even larger.

The amount of decrease due to thermal expansion can be calculated from the following equations:

$$\delta_t = \alpha \Delta_t D_e$$

Where δ_t : Internal clearance decrease (inch) due to temperature

α : Coefficient of linear expansion of bearing steel (12.5×10^{-6}) ($1/^\circ\text{C}$)

Δ_t : Temperature difference between inner & outer rings ($^\circ\text{C}$)

D_e : Outer ring raceway diameter (inch)

For Ball Bearings: $D_e = \frac{1}{5}(4D + d)$

For Roller Bearings: $D_e = \frac{1}{4}(3D + d)$

Where **D**: Bearing outside diameter (inch)

d: Bearing bore diameter (inch)

Effective Clearance

The effective, or operating, clearance Δ is obtained by subtracting δ_t from the internal clearance after mounting Δ_f . Theoretically, the longest life of a bearing can be expected when the effective clearance is slightly negative. However, it is difficult to achieve this condition and excessive negative clearance will shorten bearing life. Therefore, a clearance of zero or a slightly positive value is preferable.

Angular contact ball bearings or tapered roller bearings normally require the user to set the internal clearance at mounting. The user should check the proper orientation of these bearings by checking the original bearings or the service manual for the machine. A check should also be made for the recommended set clearance. This can be obtained from the service manual, the machine manufacturer, or the bearing manufacturer.

Preloaded Bearings

Types and Features

Rolling bearings usually retain some internal clearance while in operation. However, in some cases it is desirable to provide a negative clearance. This is called "preloading." Preloading can be used to decrease bearing deflection and provide greater bearing rigidity. However, it may also increase power consumption and reduce bearing life.

A preload is usually given to those types of bearings in which the axial clearance can be adjusted in mounting--for example, angular contact ball bearings and tapered roller bearings. Usually preloaded bearings are mounted face to face or back to back to form a duplex bearing set.

WHY PRELOAD?

Typical reasons and applications for preloading bearings are:

- To maintain bearings in an exact position in both the radial and axial directions and to maintain the running accuracy of the shaft... for example, the main shaft of machine tools and instruments.
- To increase bearing rigidity. This is often needed on the main shaft of machine tools or the pinion shaft of automobile differentials.
- To minimize noise due to axial vibration and resonance... for example, in high speed or high acceleration applications of angular contact ball bearings and thrust ball bearings
- To prevent sliding due to the gyratory movement of rolling elements... for example, in high speed or high acceleration applications of angular contact ball bearings and thrust ball bearings.
- To maintain the rolling elements in their proper position with the bearing rings... for example, on thrust ball bearings and spherical roller thrust bearings mounted on a horizontal shaft.

HOW TO PRELOAD DUPLEX BEARINGS

There are two basic methods for preloading duplex bearings--preloading by position and preloading by constant pressure:

Position Preload

Position preload is achieved by positioning two axially opposed bearings while maintaining their relative positions in operation. This is usually done by one of the following methods:

- Installing a duplex bearing set with previously adjusted stand-out dimensions and axial clearance.
- Using a spacer or shim with proper dimensions to obtain the required spacing and preload. See Figure 10.43.
- Using bolts or nuts to allow adjustment of the axial clearance. In this case the starting friction torque should be measured to verify the proper preload.

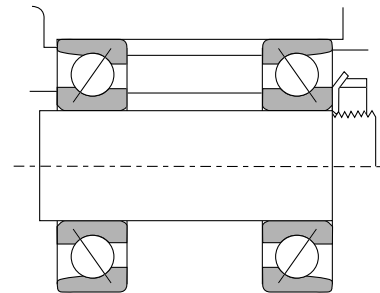

Figure 10.43 — Example of Position Preload

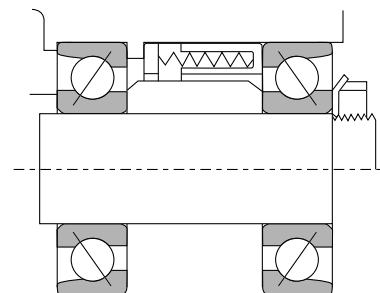

Figure 10.44 — Example of Constant Pressure Preload

Constant Pressure Preload

Constant pressure preload is achieved by using a coil or leaf spring to impose a constant preload. Even if the relative position of the bearings changes during operation, the magnitude of the preload remains relatively constant. See Figure 10.44

SELECTING PRELOADING METHOD AND THE AMOUNT OF PRELOAD TO USE

Comparison of Preloading Methods

A comparison of rigidity using different preloading methods is shown in the chart below.

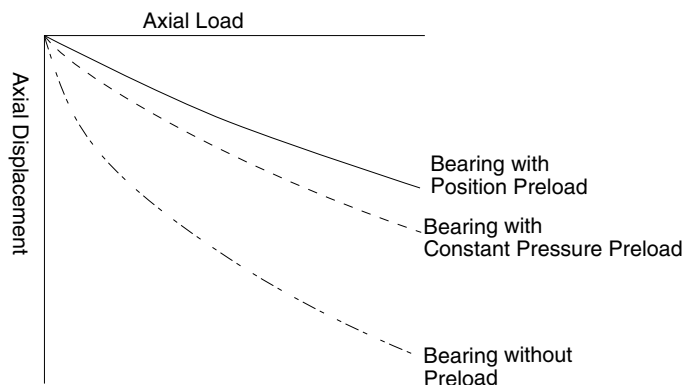

Figure 10.45 — Preload and Rigidity

Position preloading is generally preferred for increasing rigidity. Constant pressure preload is more suitable for high speed applications, prevention of axial vibration, and for use with thrust bearings on horizontal shafts. Position preload and constant pressure preload each offer specific advantages:

- When equal preloads are imposed, the position preload provides greater bearing rigidity. The deflection due to external loads is less for bearings with a position preload.
- In position preloading the level of preload varies depending on such factors as a difference in axial expansion due to a temperature difference between the inner and outer rings and deflection due to load.
- In constant pressure preloading it is possible to minimize any change in the preload because the variation of the spring load with shaft expansion and contraction is negligible.

How Much Preload to Use?

If the preload is larger than necessary, abnormal heat generation, increased frictional torque and reduced fatigue life may occur. The amount of the preload should be determined considering the operating conditions, the purpose of the preload, and the type of bearing to be preloaded.

Preload of Duplex Angular Contact Ball Bearings — The average preloads for duplex angular contact ball bearings (contact angle of 15°) with precision better than P5 class are listed in the tables on the following page. These bearings are used on the main shafts of machine tools.

The recommended fits between the shaft and inner ring, and between the housing and outer ring are listed in Table 10.31 on page 328 thru Table 10.34 on page 329.

For housing fits, the lower limit of the fit range should be selected for fixed-end bearings and the upper limit for free-end bearings.

As a general rule, an extra light or light preload should be selected for spindles of grinders and a medium preload should be selected for the main shafts of high speed lathes and milling machines.

Figure 10.46 — Preload for Duplex Angular Contact Ball Bearings (Series 7000)

Units: Lbf

Bearing Number	Preload			
	Very Light C2	Light C7	Medium C8	Heavy C9
7000C	1.21	6.38	13.26	28.55
7001C	1.33	7.08	14.28	30.80
7002C	1.43	7.76	16.52	35.30
7003C	1.54	8.43	17.65	37.54
7004C	2.86	15.40	30.80	66.09
7005C	3.08	16.52	33.05	73.06
7006C	4.18	22.03	46.31	96.67
7007C	5.51	28.55	61.82	132.64
7008C	6.38	33.05	68.57	142.75
7009C	7.76	42.26	84.30	176.48
7010C	8.54	44.06	92.17	198.96
7011C	11.02	59.57	121.40	265.28
7012C	12.14	61.82	132.64	276.52
7013C	13.26	68.57	142.75	307.99
7014C	16.52	87.68	187.72	386.67
7015C	17.65	92.17	187.72	406.91
7016C	20.91	110.16	231.55	508.07
7017C	22.03	121.40	242.79	528.30
7018C	26.53	142.75	296.75	618.23
7019C	28.55	142.75	307.99	660.94
7020C	28.55	153.99	319.23	685.67

Figure 10.47 — Preload for Duplex Angular Contact Ball Bearings (Series 7200)

Units: Lbf

Bearing Number	Preload			
	X-tra Light C2	Light C7	Medium C8	Heavy C9
7200C	1.21	6.38	13.26	28.55
7201C	1.88	9.89	20.91	44.06
7202C	2.09	11.02	22.03	48.56
7203C	2.65	14.28	28.55	61.82
7204C	3.75	19.90	39.79	85.43
7205C	4.41	24.28	48.56	103.41
7206C	6.61	33.05	70.82	153.99
7207C	8.77	46.31	94.42	198.96
7208C	11.02	57.33	121.40	254.04
7209C	12.14	63.85	132.64	285.51
7210C	13.26	70.82	142.75	307.99
7211C	16.52	87.68	187.72	397.91
7212C	20.91	110.16	231.55	485.59
7213C	24.28	132.64	265.28	573.27
7214C	26.53	142.75	296.75	618.23
7215C	28.55	153.99	319.23	660.94
7216C	33.05	165.24	352.95	753.11
7217C	37.54	198.96	406.91	876.76
7218C	44.06	231.55	485.59	1011.65
7219C	46.31	242.79	508.07	1079.09
7220C	52.83	276.52	573.27	1236.46

Figure 10.49 — Recommended Fits for Precision Class Duplex Angular Contact Ball Bearings with Preload

Nominal Bore Dia. (mm)		Target Shaft Interference (inch)	Nominal Outside Dia. (mm)		Target Housing Clearance (inch)	
Over	Incl.		Over	Incl.		
–	18	0 – 0.0001	–	18	–	–
18	30	0 – 0.0001	18	30	+0.0001	+0.0002
30	50	0 – 0.0001	30	50	+0.0001	+0.0002
50	80	0 – 0.0001	50	80	+0.0001	+0.0003
80	120	0 – 0.0002	80	120	+0.0001	+0.0004
120	150	–	120	150	+0.0002	+0.0005
150	180	–	150	180	+0.0002	+0.0005
180	250	–	180	250	+0.0002	+0.0006

Preload of Thrust Ball Bearings

When the balls in thrust ball bearings rotate at relatively high speeds, sliding due to the gyratory movement of the balls may occur. The larger of the two values obtained from the equations below should be selected as the minimum axial load in order to prevent such sliding.

$$F_{a,min} = \frac{C_{oa}}{100} \left(\frac{n}{N_{max}} \right)^2$$

Where $F_{a,min}$: Minimum axial load, N
 C_{oa} : Basic static load rating, N
 n : Rotational speed, rpm
 N_{max} : Limiting speed (oil lubrication), rpm

Preload of Spherical Roller Thrust Bearings

When spherical roller thrust bearings are used a preload is necessary to keep the rollers in proper position against the outer ring raceway. The minimum axial load $F_{a,min}$ necessary to do this is:

$$F_{a,min} = \left(\frac{C_{oa}}{1000} \right)$$

Introduction
Ball Bearings
Cylindrical Roller Bearings
Spherical Roller Bearings
Tapered Roller Bearings
Thrust Bearings
Split Pillow Blocks
Super Precision Bearings
Linear Motion
Rolling Mill Bearings
Engineering Section

Bearing Lubrication

LUBRICATION--THE PURPOSE

Lubrication is needed to reduce friction and wear inside the bearing. Proper lubrication and procedures will allow the bearing to reach its expected life.

Primarily, lubrication serves the following purposes:

- Reduces Friction and Wear – Direct metallic contact between the bearing rings, rolling elements and cage is prevented by an oil film which reduces the friction and heat at the contact areas.
- Extends Bearing Life – The rolling fatigue life of bearings depends in a large part on the viscosity and film thickness of the lubricant. A heavy film thickness prolongs the bearing fatigue life.
- Cooling – Circulating oil can be used to carry heat away from the bearing. A circulating system is normally used when excessive heat is generated by the bearing due to high speeds, high loads, or when heat from a source adjacent to the bearing can affect its operation. Oils deteriorate at high temperatures; therefore it is important to keep both the oil and the bearing cool.
- Other Purposes – Proper lubrication also helps to prevent foreign material from entering the bearings, and protects against corrosion or rusting.

SELECTING THE CORRECT LUBRICATION METHOD

Lubrication can be accomplished by using either oil or grease. The most satisfactory bearing performance will be achieved by selecting the method most suitable for a specific application. This of course will also depend on the conditions under which the bearing will operate.

Oil lubrication is superior in lubricating efficiency, however, grease lubrication allows a simpler structure around the bearings. The following table compares oil and grease lubrication.

Operating Factor	Grease Lubrication	Oil Lubrication
Housing Structure and Sealing Method	Simple	May be complex. Careful maintenance required.
Speed	Limiting speed is 65% to 80% of that of oil lubrication	High limiting speed
Cooling Effect	Poor	Heat transfer is possible using forced oil circulating lubrication
Fluidity	Poor	Good
Full Lubricant Replacement	Sometimes difficult	Easy
Removal of Foreign Matter	Removal of particles from grease is impossible	Easy
External Contamination Due to Leakage	Surroundings seldom contaminated by leakage	Often leaks without proper countermeasures. Not suitable if external contamination must be avoided

GREASE LUBRICATION

Grease Quantity

The quantity of grease to be packed in a housing depends on the housing design, rotational speeds of the bearings, characteristics of the grease selected, and the ambient temperature conditions. These factors are critical to satisfactory performance.

Introduction

Ball Bearings

Cylindrical Roller Bearings

Spherical Roller Bearings

Tapered Roller Bearings

Thrust Bearings

Split Pillow Blocks

Super Precision Bearings

Linear Motion

Rolling Mill Bearings

Engineering Section

In applications where the operating speed does not exceed one-half the rated limiting speed of the bearing, the bearing should be packed one-half to two-thirds full. If the speed of the bearing exceeds one-half the limiting speed, the quantity of grease should be reduced to one-third to one-half full and periodic regreasing scheduled. When operating conditions are not severe, the original pack of grease should last a long time without replenishment. If the operating conditions become severe, it will be necessary to regrease periodically.

Care should be taken to avoid excessive greasing as this will cause bearings to overheat.

GREASE REPLENISHMENT

Frequent grease replenishment is required when operating conditions are severe such as in high ambient temperatures or where contaminants can enter bearing housings. Routine regreasing schedules should be established. In cases where extremely severe conditions exist or the bearings are in a remote area, the bearing housing should be designed to make replenishment and replacement as simple as possible. Automatic grease systems are available and should be used.

For normal operating conditions, it may be necessary to regrease the bearing periodically to replace any grease which has leaked from the housing and to eliminate any deteriorated grease.

OIL LUBRICATION

When the operating speed exceeds the grease limiting speed listed for the bearing, oil lubrication should be used. Several methods are available and are described below. The best method to use will depend on operating conditions.

OIL BATH LUBRICATION is a common method used where bearings are operating below the listed oil limiting speed. The static oil level should be set at the center of the lowest rolling element. An oil sight level gauge should be included in the system so that proper oil level can be quickly monitored.

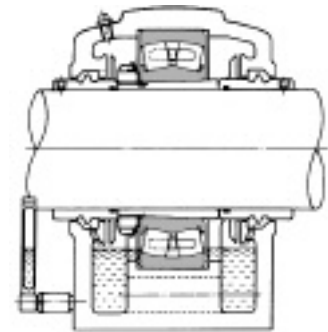

DRIP FEED LUBRICATION is often used for small bearings operated at relatively high speeds. In the illustration, a visible oiler is used. The oil drip rate is controlled by a screw valve located at the top of the oil cup.

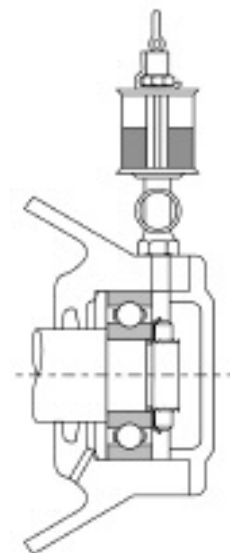

Introduction
Ball Bearings
Cylindrical Roller Bearings
Spherical Roller Bearings
Tapered Roller Bearings
Thrust Bearings
Split Pillow Blocks
Super-Precision Bearings
Linear Motion
Rolling Mill Bearings
Engineering Section

Splash Lubrication – In this lubricating method, oil is splashed onto the bearings by gears or by a simple rotating disc. This method is commonly used in automobile transmissions, differentials and gear boxes. The illustration shows splash lubrication used on a reduction gear.

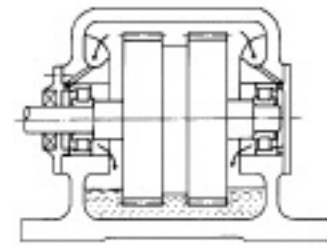

Circulating system lubrication is commonly used for high speed operation and for bearings used at high temperatures. As shown in the illustration, oil from the supply pipe circulates through the bearings and exits to an external reservoir. After cooling in the reservoir it returns to the bearing through a pump and filter. In a circulating system, the oil outlet should be larger in diameter than the supply pipe so that an excessive amount of oil will not remain in the housing.

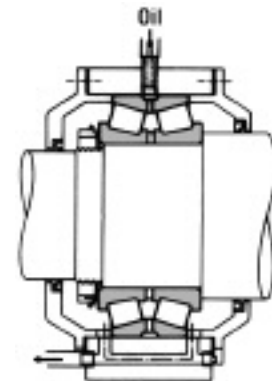
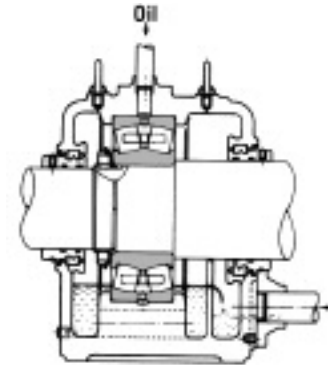

Jet Lubrication is often used for ultra high speed bearings, such as the bearings in jet engines and in machine tool spindles. In this method, lubricating oil is sprayed under pressure from one or more nozzles directly into the rolling elements of the bearing. The illustration shows an example of typical jet lubrication.

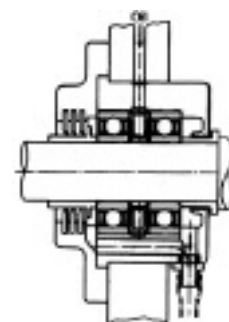
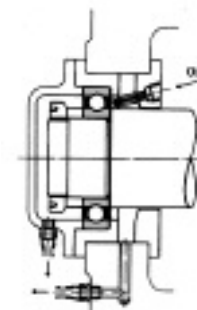

Oil Mist Lubrication, – also called oil fog lubrication, uses air to atomize the oil and carry it into the bearing. This method is used in bearings for the ultra high-speed spindles of machine tools, high-speed rotary pumps, and roll necks of rolling mills, as shown in the illustration.

In **Oil/Air Lubrication** systems, a small quantity of oil is periodically injected into an air stream which carries it to the bearing. This system is used when it is necessary to precisely control the quantity of oil entering the bearing to control operating temperature.

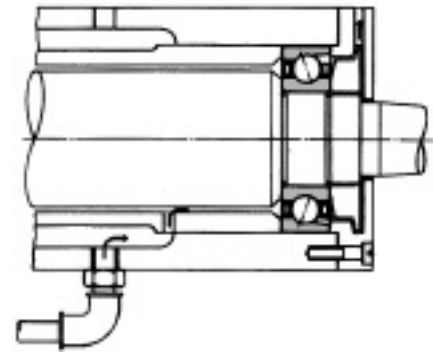

Introduction
Ball Bearings
Cylindrical Roller Bearings
Spherical Roller Bearings
Tapered Roller Bearings
Thrust Bearings
Split Pillow Blocks
Super Precision Bearings
Linear Motion
Rolling Mill Bearings

Lubricants

LUBRICATING GREASE

Grease is a semi-solid lubricant of a base oil and a thickener. Other ingredients are sometimes added to impart special properties to the base.

The main types and general properties of grease are shown in Table 10.50 on page 343. It should be noted that different brands of the same type of grease may have different properties.

Base Oil – Mineral oil or synthetic oils such as silicon or diester oil, are commonly used as the base oil for grease. The lubricating properties of grease are dependent on the characteristics of its base oil. The viscosity of the base oil is an important consideration when selecting grease. Usually grease made with a low viscosity base oil is more suitable for high speeds and low temperatures while grease made with high viscosity base oils is more suited for high temperatures and heavy loads. The thickener also influences the lubricating properties of grease, therefore selection criteria for grease are not the same as for lubricating oil.

Thickener – Several types of metallic soaps, inorganic compounds such as silica gel and bentonite, and heat resisting organic thickeners such as polyurea and flouric compounds are used as thickeners for grease. The water resistance properties of grease depend on the type of thickener. Sodium soap grease (or compound grease containing sodium soap) emulsifies when exposed to water or high humidity and therefore cannot be used where moisture is prevalent. Lithium soap grease, on the other hand, is recommended where moisture is present because of its resistance to wash off.

For applications where the operating temperature exceeds the limitation of common multi-purpose grease, greases having complex bases or non-soap bases are recommended. The grease used should also have a synthetic oil to withstand rapid deterioration at high temperatures. If the grease used in a high temperature application uses a mineral oil, it should be replenished frequently as deterioration of the oil will be accelerated at high temperatures.

Additives – Grease often contains a variety of additives such as antioxidants, corrosion inhibitors, and extreme pressure additives to give it special properties. Extreme pressure additives are recommended for use in heavy load applications. For long use without replenishment, an antioxidant should be added.

Consistency – Consistency indicates the “softness” of the grease. The following table shows the relationship between consistency and working conditions.

		Consistency Number (Given by the National Lubricating Grease Institute (NLGI) Scale)				
		0	1	2	3	4
Consistency ¹⁾ (1/10 mm)		385~355	340~310	295~265	250~220	205~175
Working Condition		For centralized oiling. When false brinelling is liable to occur.	For centralized oiling. When fretting is liable to occur. For low temperature.	For general use. For sealed bearings.	For high temperature. For general use. For sealed bearings	For high temperature. For grease seals

1) Consistency: Depth into grease attained by a cone when pressed with a specified weight, indicated in units of 1/10 mm. The larger the value, the softer the grease.

Mixing Different Types of Grease – In general, grease of different types must not be mixed. Mixing grease with different types of thickeners may destroy the composition and physical properties of the grease. Even if the thickeners are of the same type, possible differences in the additives may cause detrimental effects.

Introduction

Ball Bearings

Cylindrical Roller Bearings

Spherical Roller Bearings

Tapered Roller Bearings

Thrust Bearings

Split Pillow Blocks

Super Precision Bearings

Linear Motion

Rolling Mill Bearings

Engineering Section

Figure 10.50 — Grease Properties

Popular Name →	Lithium Grease			Sodium Grease (Fiber Grease)	Calcium Grease (Cup Grease)	Mixed Base Grease	Complex Grease	Non-Soap Base Grease		
	Thickener →	Li Soap			Na Soap	Ca Soap	Na+Ca Soap, Li +Ca Soap, etc.	Ca Complex, A1 Complex, etc.	Silica Gel, Bentonite, Carbon Black, Polyurea, Flouric Compounds, Heat Resistant Organic Compound, etc.	
		Base Oil →	Mineral Oil	Diester Oil	Silicone Oil	Mineral Oil	Mineral Oil	Mineral Oil	Mineral Oil	Mineral Oil
Property ⁽¹⁾	Dropping Point, C°	170~190	170~195	200~210	170~210	70~90	160~190	180~300	230	240~
	Working Temp., C°	-20~110	-50~130	-50 ~160	-20~130	-20 ~60	-20~80	-20 ~130	-10 ~130	~250
	Working Speed, % ⁽²⁾	70	100	60	70	40	70	70	70	40~100
	Mechanical Stability	Good	Good	Good	Good	Poor	Good	Good	Good	Good
	Pressure Resistance	Fair	Fair	Poor	Fair	Poor	Fair to Good	Fair to Good	Fair	Fair
	Water Resistance	Good	Good	Good	Poor	Good	Poor for Na Soap Grease	Good	Good	Good
	Rust Prevention	Good	Good	Poor	Poor to Good	Good	Fair to Good	Fair to Good	Fair to Good	Fair to Good
	Remarks	General purpose lubricant.	Good low temperature and torque characteristics. Often used for small motor and instrument bearings	Mainly for high temperature applications. Unsuitable for bearings under high speed or heavy load conditions or for sliding contact areas (roller bearings)	Long and short fiber types available. Long fiber grease is not suitable for high speeds or for sliding contact areas (roller bearings)	Not suitable for high temp. and heavy loads. Extreme pressure grease containing high viscosity oil and extreme pressure additive (Pb soap, etc.) is available	Often used for roller bearings and large ball bearings	Suitable for extreme pressures. Mechanically stable.	Medium and high temperature lubricant	Recommended for special environments with very high and low temperatures, acids, alkalis, radioactivity, and exposure to flames.

(1) The grease properties shown here can vary between different brands.
 (2) The values listed are percentages of the limiting speeds given in the bearing tables.

Lubricating Oil

Lubricating oil used for bearings is usually a highly refined mineral or synthetic oil which has a high film strength and superior oxidation and corrosion resistance. When selecting an oil, the viscosity of the operating conditions is very important. If the viscosity is too low, a proper oil film is not formed and abnormal wear and seizure may occur. On the other hand, if the viscosity is too high, excessive viscous resistance may cause heating or a large power loss. In general, low viscosity oils should be used at high speeds. Higher viscosity oils should be used for heavy loads or for the larger bearings. The following table shows the generally recommended viscosity for certain bearing types.

Bearing Types	Proper Viscosity at the Operating Temperature
Ball Bearings and Cylindrical Roller Bearings	Higher than 13 cSt
Tapered Roller Bearings and Spherical Roller Bearings	Higher than 20 cSt
Spherical Roller Thrust Bearings	Higher than 32 cSt

Introduction
 Ball Bearings
 Cylindrical Roller Bearings
 Spherical Roller Bearings
 Tapered Roller Bearings
 Thrust Bearings
 Split Pillow Blocks
 Super Precision Bearings
 Linear Motion
 Rolling Mill Bearings
 Engineering Section

The following chart shows the relationship between temperature and viscosity for use in selection of the proper lubricating oil.

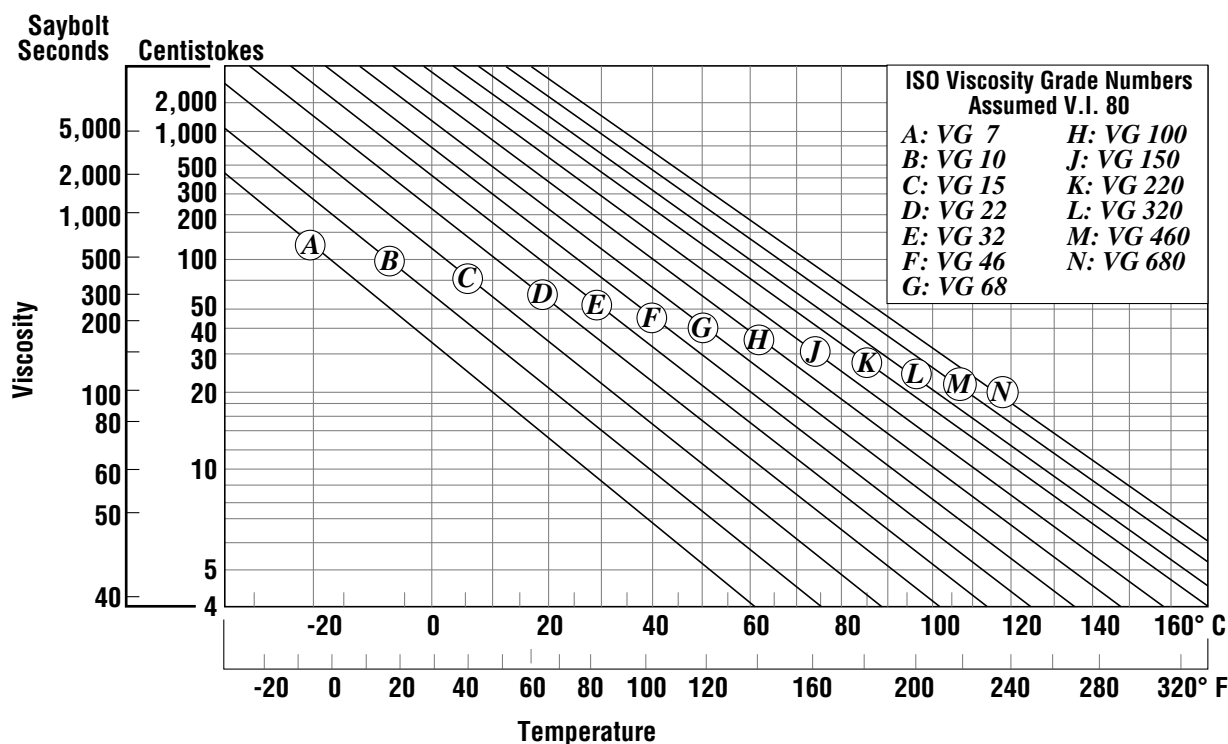

Table 10.51 – Temperature – Viscosity Chart

Oil Replacement Interval – The oil replacement interval depends on the operating conditions and oil quantity. In those cases where the operating temperature is less than 120°F and the environmental conditions are good, oil should be replaced approximately once a year. However, where the oil temperature is about 212°F the oil must be changed at least once every three months.

In dirty environmental conditions, or if moisture or foreign material is mixed in the oil, the replacement interval must be shortened.

Mixing different brands of lubricating oil should be avoided.

Introduction

Ball Bearings

Cylindrical Roller Bearings

Spherical Roller Bearings

Tapered Roller Bearings

Thrust Bearings

Split Pillow Blocks

Super Precision Bearings

Linear Motion

Rolling Mill Bearings

Engineering Section

HOW TO HANDLE BEARINGS

Rolling bearings are high precision machine parts and need to be handled carefully. When installing or removing a bearing, correct procedures should be followed. Careless handling during mounting and removal could result in a serious accident, injuring people and damaging property.

Whether installing, removing, mounting, dismounting, replacing or inspecting, a few simple precautions must be followed:

Keep Bearings and Surroundings Clean!

Dust and dirt, even if invisible to the naked eye, can harm bearings. To prevent the entry of dust and dirt, keep bearings and their environment as clean as possible. Never remove a bearing from its package until you are ready to mount it.

Handle With Care!

Heavy shocks during handling may cause bearings to be scratched or otherwise damaged. Excessively strong impacts when mounting, dismounting or handling may cause brinelling, breaking or cracking.

Use Proper Tools!

Always use the proper equipment and tools to install or remove bearings. Avoid using general purpose tools such as hammers, screwdrivers, wrenches and pliers.

Protect Bearings From Corrosion!

Keep hands clean when handling bearings. Perspiration and other contaminants on the hands can cause corrosion on the bearings. Wear gloves, if possible. Apply oil or grease to non-sealed bearings immediately after installation for further protection.

MOUNTING--FACTORS TO CONSIDER

Bearings are very precise and their mounting requires careful attention. The following items must be considered:

- Cleaning related parts
- Dimensions and finish of related parts
- Mounting procedures
- Inspection after mounting
- Supply of lubricants.

Prelubricated bearings and bearings lubricated with ordinary oil or grease should not be washed before installation. The preservative used on the bearing to protect it during storage is compatible with most common lubricants.

Bearings used for instruments or high speed applications, such as machine tool bearings, can be washed before installation to remove the anti-corrosion agent used in manufacturing. These bearings must be washed in clean, filtered oil and protected from corrosion until they are installed and lubricated.

Bearing mounting methods depend on bearing type and the type of fit. As bearings are usually used with rotating shafts, the inner rings require a tight fit. Bearings with cylindrical bores are usually

mounted by pressing through the inner ring on the shafts (press fit) or heating them to expand their diameter (shrink fit). Bearings with tapered bores can be mounted directly on tapered shafts or on cylindrical shafts by using tapered sleeves.

Bearings are usually mounted in housings with a loose fit. However, if the outer ring has an interference fit, a press may be used. Bearings can be interference fitted by cooling before mounting, using dry ice. If this is done, a rust preventive treatment must be applied to the bearings because moisture in the air will condense on bearing surfaces.

MOUNTING BEARINGS WITH CYLINDRICAL BORES

Press Fits – Fitting with a press is widely used for small bearings. Before mounting, oil should be applied to the fitted shaft surface to make insertion smoother. A mounting tool is placed on the inner ring as shown in Figure 10.52. The mounting tool must not be placed on the outer ring for press mounting, because this may damage the bearing. The bearing is slowly pressed onto the shaft until the side of the inner ring rests against the shoulder of the shaft.

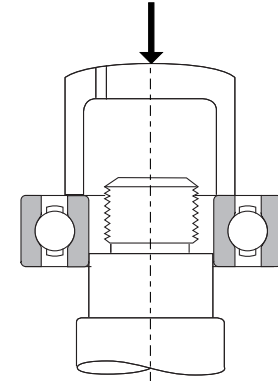

Figure 10.52 – Press Mounting of Inner Ring

Using a hammer for mounting should only be done if pressing equipment is not available. Any time a hammer is used, a mounting tool must be placed on the inner ring. For tight interference fits or for medium and large bearings, a hammer should never be used.

When both the inner and outer rings of non-separable bearings, such as deep groove ball bearings, require a tight fit, a mounting tool should be placed on both rings and both rings fitted at the same time using a screw or hydraulic press. See Figure 10.53.

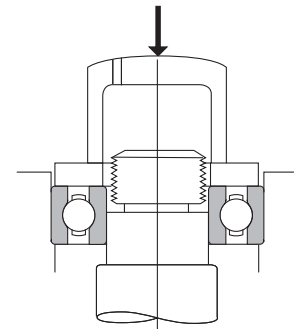

Figure 10.53 – Simultaneous Press Mounting of Inner & Outer Ring

When mounting separable bearings, such as cylindrical roller bearings and tapered roller bearings, the inner and outer rings may be mounted separately.

A mounting tool such as that shown in Figure 10.53 should also be used for mounting self-aligning bearings. Assembly of the inner and outer rings which were previously mounted separately must be done carefully to align them correctly. Careless or forced assembly may cause scratches on the rolling contact surfaces.

Shrink Fits – Shrink fitting is often used to avoid the large force involved in press fitting large bearings. This method eliminates the need to impose excessive force on the bearings. For shrink fitting, the bearings are first heated in oil, or in an induction heater, to expand them, then mounted and allowed to cool.

This amount of expansion of the inner ring for various temperature differences and bearing sizes are shown in Figure 10.54

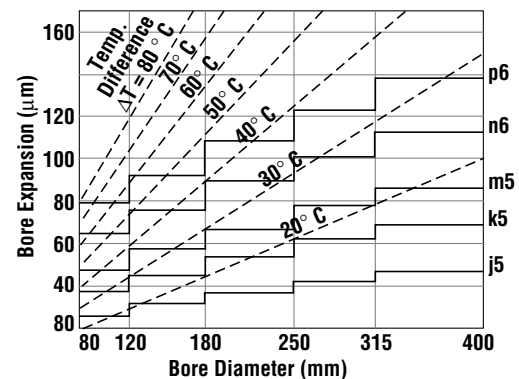

Figure 10.54 – Temperature and Expansion of Inner Ring

A few precautions to be considered when making shrink fits:

- Do not heat bearings to more than 248°F.
- Put bearings on a wire netting or suspend them in the oil tank to prevent them from touching the tank bottom.

- Heat bearings to a temperature 68 to 86°F higher than the lowest temperature required for mounting, because the inner ring will cool a little during mounting.

After mounting, the bearings will shrink in the axial direction as well as the radial direction while cooling. Therefore, while mounting, press the bearing firmly against the shaft shoulder to avoid excessive clearance between the bearing and the shoulder. Mixing different brands of lubricating oil should be avoided.

MOUNTING BEARINGS WITH TAPERED BORES

Bearings with tapered bores can be mounted on tapered shafts directly or on cylindrical shafts by using tapered adapters or withdrawal sleeves.

Large spherical bearings are often mounted using hydraulic pressure. Figure 10.55 shows two different hydraulic mounting methods. One method is a sleeve with a hydraulic nut. The other method uses a sleeve with pressurized oil. Holes drilled in the sleeve are used to feed oil under pressure to the bearing seat. As the bearing expands radially, the sleeve is inserted axially with adjusting bolts.

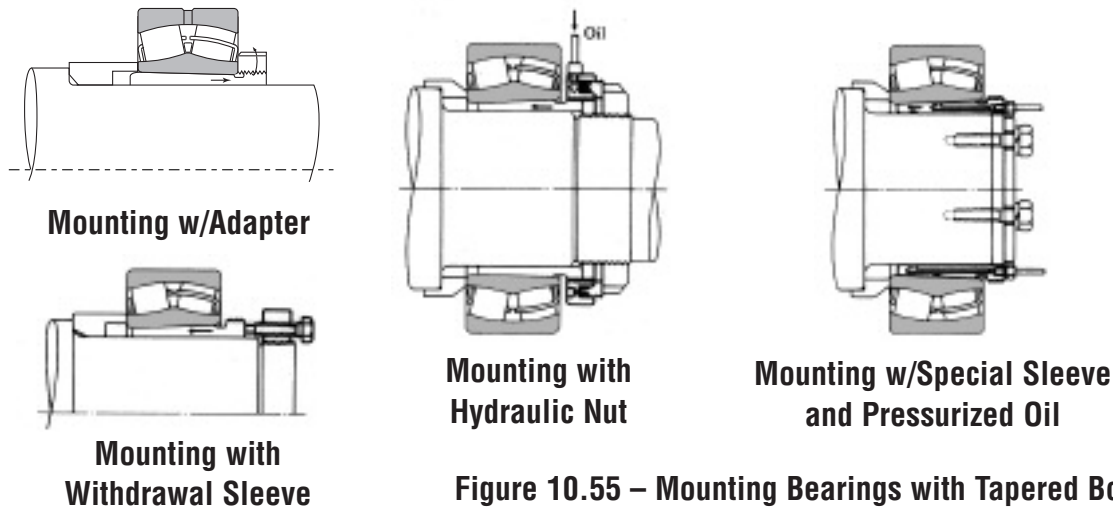

Figure 10.55 – Mounting Bearings with Tapered Bores

The internal clearance of a tapered bore bearing varies with the tightness of the interference fit. It is necessary to check the clearance often as the bearing is being mounted. The bearing should be pressed until the reduction of radial clearance is within the range shown in Table 10.56 on page 348.

Table 10.56 — Mounting of Spherical Roller Bearings with Tapered Bores

Units: Inch

Nominal Bore Diameter (mm)		Radial internal Clearance (inches)						Reduction in Radial Clearance		Axial Movement				Minimum Permissible Residual Clearance After Mounting		
		Normal		C3		C4				Taper 1:12		Taper 1:30				
over	incl.	min	max	min	max.	min.	max.	min.	max.	min.	max.	min.	max.	Normal	C3	C4
30	40	.0014	.0020	.0020	.0026	.0026	.0033	.0005	.0010	.011	.016	-	-	.0006	.0012	.0018
40	50	.0018	.0024	.0024	.0032	.0032	.0041	.0010	.0010	.014	.018	-	-	.0006	.0012	.0020
50	65	.0022	.0030	.0030	.0039	.0039	.0049	.0010	.0015	.018	.024	-	-	.0010	.0014	.0024
65	80	.0028	.0037	.0037	.0049	.0049	.0061	.0015	.0020	.024	.032	-	-	.0012	.0016	.0030
80	100	.0032	.0044	.0044	.0057	.0057	.0075	.0020	.0025	.027	.040	.070	.085	.0014	.0020	.0032
100	120	.0039	.0053	.0053	.0069	.0069	.0089	.0020	.0030	.030	.048	.075	.090	.0018	.0026	.0040
120	140	.0047	.0063	.0063	.0081	.0081	.0102	.0025	.0035	.040	.056	.090	.110	.0022	.0031	.0045
140	160	.0051	.0071	.0071	.0091	.0091	.0118	.0030	.0040	.048	.062	.100	.130	.0024	.0039	.0050
160	180	.0055	.0079	.0079	.0102	.0102	.0134	.0030	.0045	.048	.069	.110	.140	.0028	.0043	.0060
180	200	.0063	.0088	.0088	.0114	.0114	.0146	.0035	.0050	.056	.082	.130	.160	.0028	.0043	.0065
200	225	.0071	.0099	.0099	.0126	.0126	.0162	.0040	.0055	.064	.088	.140	.170	.0031	.0051	.0070
225	250	.0079	.0106	.0106	.0140	.0140	.0178	.0045	.0060	.072	.094	.160	.190	.0035	.0055	.0080
250	280	.0087	.0118	.0118	.0156	.0156	.0195	.0050	.0070	.080	.106	.170	.220	.0039	.0059	.0085
280	315	.0094	.0130	.0130	.0169	.0169	.0213	.0050	.0070	.080	.118	.190	.240	.0043	.0063	.0095
315	355	.0106	.0142	.0142	.0187	.0187	.0234	.0060	.0080	.096	.131	.220	.270	.0047	.0071	.0105
355	400	.0118	.0157	.0157	.0207	.0207	.0258	.0070	.0090	.104	.144	.240	.300	.0051	.0079	.0115
400	450	.0130	.0173	.0173	.0224	.0224	.0283	.0080	.0100	.128	.160	.270	.330	.0055	.0087	.0125
450	500	.0146	.0193	.0193	.0248	.0248	.0311	.0090	.0110	.136	.176	.300	.360	.0063	.0094	.0140
500	560	.0161	.0213	.0213	.0275	.0275	.0343	.0100	.0130	.152	.208	.340	.430	.0067	.0106	.0155
560	630	.0180	.0236	.0236	.0307	.0307	.0386	.0100	.0140	.160	.224	.360	.470	.0079	.0122	.0170
630	710	.0201	.0264	.0264	.0335	.0335	.0429	.0120	.0160	.192	.256	.410	.510	.0087	.0130	.0185
710	800	.0224	.0295	.0295	.0378	.0378	.0480	.0130	.0180	.208	.288	.450	.590	.0094	.0154	.0210
800	900	.0252	.0331	.0331	.0421	.0421	.0539	.0140	.0200	.224	.320	.490	.650	.0110	.0169	.0230
900	1000	.0280	.0366	.0366	.0470	.0470	.0600	.0160	.0220	.256	.352	.550	.730	.0122	.0185	.0260

For Pe less than 0.13Cr, use the lower half of the reduction range. For heavier loads Pe greater than 0.13Cr, carburized or TL inner rings should be specified and the upper half of the range can be used.

Radial internal clearance can be measured during mounting using a feeler gauge or other appropriate gauges. In this process, the clearances for both rows of rollers must be measured simultaneously and the two values kept roughly the same by adjusting the relative position of the outer and inner rings. This is shown in Fig. 1. The average of the two measurements taken for both rows may be used as the residual internal clearance.

In large bearings, the outer ring may deform slightly into an elliptical shape due to its own weight. In this case, for best results, measurements should be taken at locations **a**, **b**, and **c** (see Fig. 2) and entered into the following equation:

$$\text{radial clearance} = (a + b + c)/2$$

This method is used where the bearing is resting on its outer ring (radial clearance **c** at bottom). When a self-aligning ball bearing is mounted on a shaft adapter, sufficient clearance for easy alignment of the outer ring must be allowed.

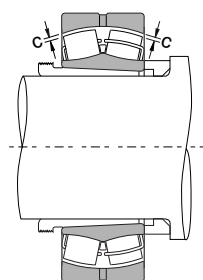

Figure 1

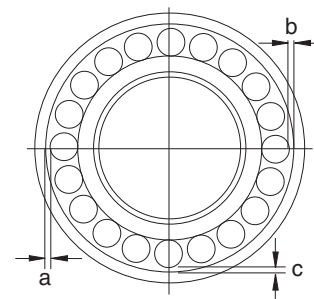

Figure 2

INSPECTING AND TROUBLESHOOTING

After mounting has been completed, a running test should be conducted to determine that the bearing has been mounted properly.

Small machines may be manually operated to assure that they rotate smoothly. Items to be checked include sticking due to foreign matter, visible flaws, uneven torque, and excessive torque caused by inadequate clearance, mounting error or seal friction.

Large machines which cannot be operated manually, may be started with no load, then the power immediately cut off to allow the machine to coast to a stop. There should be no abnormal vibration, noise or contact between rotating parts. Normal powered operation may be started after this examination. Powered operation should be started slowly, without load, and the operation should be observed until it is determined that no abnormalities exist. Items to be checked during the test operation include abnormal noise, excessive rise of bearing temperature, leakage and discoloration of lubricants. Abnormal noise conditions are indicated by a loud metallic sound or other irregular noise. Possible causes of noise may include incorrect lubrication, poor alignment of the shaft and housing, and foreign matter in the bearing.

Bearing temperature may generally be estimated by the temperature of the outside surface of the housing, but it is more desirable to directly measure the temperature of the outer ring using oil holes for access. Bearing temperature should rise gradually to the steady state level within one to two hours after operation. If the bearing or mountings are improper, bearing temperature may increase rapidly and become abnormally high. Possible causes may include an excessive amount of lubricant, insufficient clearance, incorrect mounting, or excessive friction of the seals. In the case of high speed operation, an incorrect selection of bearing type or lubricating method may also cause an abnormal temperature rise.

Possible causes and countermeasures for operating irregularities are shown in Table 10.57 on page 350.

Table 10.57 — Causes and Countermeasures for Operating Irregularities

	Irregularities	Possible Causes	Countermeasures
Introduction Ball Bearings Cylindrical Roller Bearings Spherical Roller Bearings Tapered Roller Bearings	Noise	Abnormal Load	Correction of fit, internal clearance, preload, position of housing shoulder, etc.
		Incorrect mounting	Correction of alignment of shaft and housing, accuracy of mounting method.
		Insufficient or improper lubricant	Replenish lubricant or select proper lubricant.
		Squeaking noise	Replacement by low-noise bearings, selection of small clearance bearings.
		Sliding of balls	Adjustment of preload, selection of small clearance bearings, or adoption of softer grease.
		Contact of rotating parts	Correction of labyrinth seal, etc.
	Loud Metallic Sound	Flaws, corrosion, or scratches on the raceways	Replacement of bearing, cleaning, improvement of seals, and usage of clean lubricant.
		Brinelling	Replacement of bearing and careful handling.
		Flaking on the raceways	Replacement of bearing
	Loud Regular Sound	Excessive clearance	Correction of fit and clearance and correction of preload
Penetration by foreign particles		Replacement of bearing, cleaning, improvement of seals, and relubrication using clean lubricant.	
Flaws or flaking on the ball surfaces		Replacement of bearing	
Excessive amount of lubricant		Reduce amount of lubricant, select stiffer grease.	
Irregular Sound	Insufficient or improper lubricant	Replenish lubricant or select proper lubricant.	
	Abnormal load	Correction of fit, internal clearance, preload, position of housing shoulder.	
	Incorrect mounting	Correction of alignment of shaft and housing, accuracy of mounting, or mounting method.	
	Creep of fitted surfaces, excessive seal friction.	Correction of seals, replacement of bearing, correction of fit or mounting.	
Abnormal Temperature Rise	Brinelling	Replacement of bearings and careful handling.	
	Flaking	Replacement of bearing	
	Incorrect mounting	Correction of squareness between shaft and housing shoulder or side of spacer.	
	Penetration by foreign particles	Replacement of bearing, cleaning, correction of seals.	
Vibration	To much lubrication. Penetration by foreign particles or abrasion chips.	Reduce amount of lubricant, select stiffer grease. Replace bearing or lubricant. Clean housing and adjacent parts.	
Leakage or Discoloration of Lubricant			

Introduction
Ball Bearings
Cylindrical Roller Bearings
Spherical Roller Bearings
Tapered Roller Bearings
Thrust Bearings
Split Pillow Blocks
Super Precision Bearings
Linear Motion
Rolling Mill Bearings
Engineering Section

HOW TO DISMOUNT BEARINGS

It may be necessary to remove bearings for periodic inspection or for other reasons. If the removed bearing is to be used again, it should be dismantled as carefully as when it was mounted. If the bearing has a tight fit, removal may be difficult. Dismounting procedures and the sequence of removal should be studied carefully before beginning the job.

Dismounting of Outer Rings

Housings are not normally supplied with facilities to allow easy bearing removal. However, if it is necessary to periodically remove the bearing for inspection or replacement, special features can be incorporated to ease removal. One method is to provide tapped holes, in a minimum of three places equally spaced as illustrated in Figure 10.58. Larger bearings will require more holes. By placing bolts in the holes and tightening evenly, the bearing will be forced out of the housing.

Another method is to provide slots in the housing shoulder as shown here. This allows the use of a press to allow safe removal of the bearing.

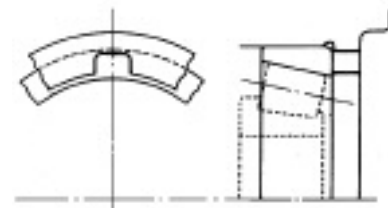

Dismounting of Bearings with Cylindrical Bores

If the mounting design allows space to press out the inner ring, this is an easy and fast method. In this method, the withdrawal force should be imposed only on the inner ring. When it is not possible to use a press, bearing pullers like those shown in Figure 10.58 are often used. The claws of these tools must fully engage the face of the inner ring, therefore it may be necessary to cut grooves in the shoulder to accommodate the tools.

The oil injection method is usually used for the withdrawal of large bearings. Withdrawal is achieved easily by means of oil pressure applied through holes in the shaft. In the case of extra wide bearings, the oil injection method is often used along with bearing pullers.

Induction heating is used to remove the inner rings of rollneck type, four row cylindrical roller bearings. The inner rings are expanded by brief local heating and then withdrawn.

Dismounting of Bearings with Tapered Bores

When dismantling relatively small bearings with adapter sleeves, the inner ring is held by a backing ring fastened to the shaft and the nut is loosened several turns. This is followed by hammering on the sleeve using a suitable tool. See Figure 10.58. It may be possible to dismount a withdrawal sleeve by tightening the removal nut. If this procedure is difficult, it may be possible to drill and tap bolt holes in the nut and withdraw the sleeve by tightening the bolts. The two methods for removal of the sleeve are illustrated in Figure 10.58.

Large bearings with tapered bores may be withdrawn easily using oil pressure. Figure 10.58 illustrates the removal of a bearing by forcing oil under pressure through a hole and groove in a tapered shaft to expand the inner ring. When this method is used, the bearing may suddenly move axially when interference is relieved, so a stop nut is recommended for protection. Figure 10.58 also shows a withdrawal using a hydraulic nut.

Introduction

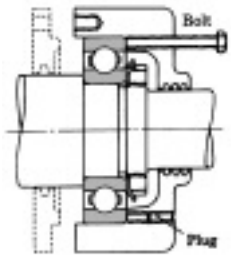

Removal of Outer Ring with Dismounting Bolts

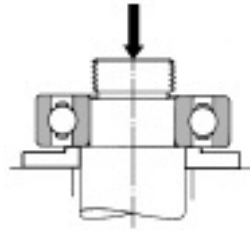

Removal of Inner Using a Press

Ball Bearings

Cylindrical Roller Bearings

Spherical Roller Bearings

Tapered Roller Bearings

Thrust Bearings

Split Pillow Blocks

Super Precision Bearings

Linear Motion

Rolling Mill Bearings

Engineering Section

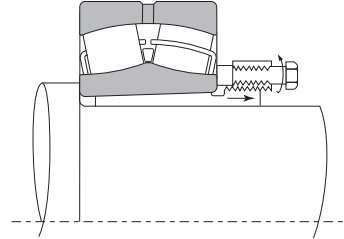
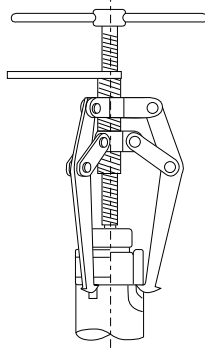
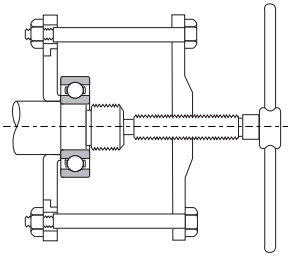

Removal of Withdrawal Sleeve with Withdrawal Nut

Removal of Inner Ring with Withdrawal Tools

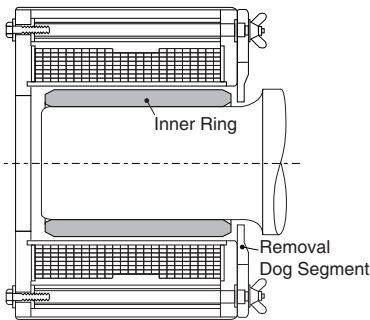

Removal of Inner Ring Using an Induction Heater

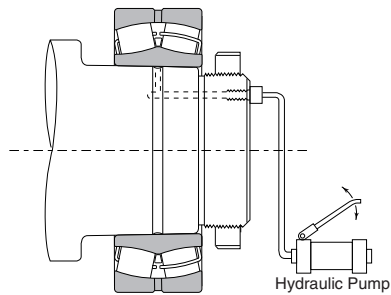
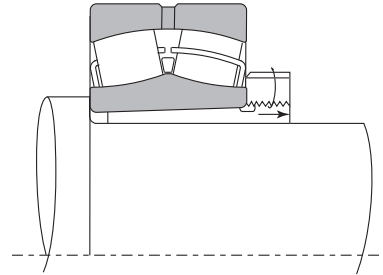

Removal Using Oil Injection

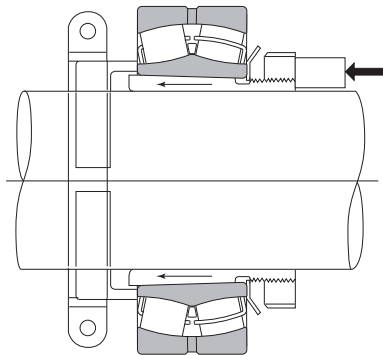

Removal of Adapter with Stop and Axial Pressure

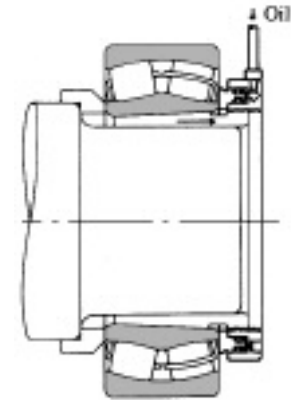

Removal Using a Hydraulic Nut

CLEANING, INSPECTION AND EVALUATION

Cleaning Bearings

When bearings are inspected, their appearance should first be recorded and the amount and condition of the residual lubricant checked. After the lubricant has been sampled for examination, the bearing should be cleaned. In general, light oil or kerosene may be used as a washing solution. Dismounted bearings should first be given a preliminary cleaning followed by a finishing rinse. Each cleaning tank should be provided with a metal net to suspend the bearings in the oil without touching either the sides or bottom of the tank.

If the bearings are rotated with foreign matter in them during cleaning, the raceways may be damaged. The lubricant and other deposits should be removed in the oil bath during the initial rough cleaning with a brush or other means. After the bearing is relatively clean, it should be given a finishing rinse. The bearing should be rotated while immersed in the rinsing oil. The rinsing oil must always be kept clean.

Inspection and Evaluation

After being thoroughly cleaned, bearings should be examined for the condition of their raceways and external surfaces, the amount of cage wear, the increase in internal clearance and degradation of tolerances. These must be carefully checked to determine the possibility of bearing reuse.

In the case of small non-separable ball bearings, hold the bearing horizontally in one hand and rotate the outer ring to confirm that it turns smoothly. Separable bearings such as tapered roller bearings, may be checked by individually examining their rolling elements and the outer ring raceway. Large bearings cannot be rotated manually. However, the rolling elements, raceway surfaces, cages and contact surface of the ribs should be carefully examined visually.

The determination to reuse a bearing should be made only after considering the degree of bearing wear, the function of the machine, the importance of the bearing in the machine, operating condition, and the time until next inspection. If any of the following defects exist, the bearing should be replaced:

- Cracks or dents in the inner or outer ring raceways, rolling elements or cage
- Flaking of the raceways or rolling elements
- Significant scratching of the raceway surfaces, ribs or rolling elements
- Worn cages or loose rivets
- Rust or flaws on the raceway surfaces or rolling elements
- Significant impact or brinell traces on the raceway surfaces or rolling elements
- Discoloration by heat
- Significant damage to the seals or shields of grease sealed bearings

MAINTENANCE AND INSPECTION

Correcting Irregularities

In order to maintain the original performance of a bearing for as long as possible, proper maintenance and inspection should be performed. If proper procedures are used, many bearing problems can be avoided. Periodic maintenance following specified procedures is mandatory. This includes supervision of operating conditions, supply or replacement of lubricants, and regular periodic inspection.

Items that should be regularly checked during operation include bearing noise, vibration, temperature and lubrication. If an irregularity is found during operation, the cause should be

Introduction

determined and the proper corrective action taken immediately. If necessary, the bearing should be dismantled and examined in detail. Refer to Table 10.57 on page 350 for causes and corrections of operating irregularities.

Ball Bearings

It is very important to detect signs of irregularities early in operation. The **NSK** Bearing Monitor is a device that checks the condition of bearings and gives a warning of any abnormality. It can also be used to stop the machine automatically in order to prevent serious damage. It also helps to improve the level of and attention to maintenance schedules and procedures. Contact **NSK** for further information.

Cylindrical Roller Bearings

Bearing Failures – Cause and Correction

In general, if rolling bearings are correctly used, they will survive to their predicted fatigue life. Premature failure is usually caused by improper mounting or dismounting, improper lubrication, penetration of foreign material, or inadequate inspection and maintenance.

Spherical Roller Bearings

It is often difficult to determine the real causes of premature failure. If all the conditions leading up to the time of failure are studied, it may be possible to avoid or reduce similar failures in the future.

The most frequent types of bearing failure, along with causes and corrective actions, are shown in Table 10.59 on page 355.

Tapered Roller Bearings

Thrust Bearings

Split Pillow Blocks

Super Precision Bearings

Linear Motion

Rolling Mill Bearings

Engineering Section

Table 10.59 — Causes and Countermeasures for Bearing Failures

	Type of Failure	Probable Cause	Counter Measures
Flaking	Flaking of one-side of the raceway of radial bearings Flaking of the raceways of double row bearings.	Abnormal axial load.	A loose fit should be used when mounting the outer ring of free-end bearings to allow axial expansion of the shaft.
	Flaking of the raceway in a symmetrical pattern	Out of roundness of the housing bore.	Correct the faulty housing.
	Flaking pattern inclined relative to the raceway in radial ball bearings. Flaking near the edge of the raceway and rolling surfaces in roller bearings.	Improper mounting, deflection of shaft, inadequate centering, inadequate tolerances for shaft and housing.	Use care in mounting and centering, select a bearing with a larger clearance, and correct the squareness of the shaft and housing shoulder.
	Flaking of raceway with same spacing as rolling elements.	Large shock load during mounting, rusting while bearing is out of operation for a prolonged period.	Use care in mounting and apply a rust preventive when machine operation is suspended for a long time.
	Premature flaking of raceways and rolling elements.	Insufficient clearance, excessive load, improper lubricant, rust, etc.	Select proper fit, bearing clearance, and lubricant.
	Premature flaking of duplex bearing	Excessive preload.	Adjust the preload.
Scoring and Smearing	Scoring or smearing between raceway and rolling surfaces.	Inadequate initial lubrication, excessively hard grease and high acceleration in starting.	Use a softer grease and avoid rapid acceleration.
	Spiral scoring or smearing of raceway surface of thrust ball bearing.	Raceway rings are not parallel and excessive speed.	Correct the mounting, apply a preload, or select another bearing type.
	Scoring or smearing between the end face of the rollers and guide rib.	Inadequate lubrication, incorrect mounting and large axial load.	Select proper lubricants and modify the mounting.
Cracks	Crack in outer or inner ring.	Excessive shock load, excessive interference fit, incorrect shaft cylindricity, improper amount of sleeve taper, large fillet radius, development of thermal cracks and advancement of flaking.	Examine the loading conditions, modify the fit of bearing sleeve. The fillet radius must be smaller than the bearing chamfer.
	Crack in rolling element. Break in rib.	Advancement of flaking, shock applied to the rib during mounting or dropped during handling.	Be careful in handling and mounting.
	Fracture of cage.	Abnormal loading of cage due to incorrect mounting and improper lubrication.	Reduce the mounting error and review the lubricating method and lubricant.
Indentation	Indentations on raceway in same pattern as rolling elements	Shock load during mounting or excessive load when not rotating.	Use care in handling.
	Indentations on raceway and rolling elements.	Foreign matter such as metallic chips or sand.	Clean the housing, improve the seals, and use a clean lubricant.
Abnormal Wear	False brinelling (phenomenon similar to brinelling).	Vibration of the bearing without rotation during shipment or rocking motion of small amplitude.	Secure the shaft and housing, use oil as a lubricant and reduce vibration by applying a preload.
	Fretting.	Slight wearing of the fitting surface.	Increase interference and apply oil.
	Wearing of raceway, rolling elements, rib and cage.	Penetration by foreign matter, incorrect lubrication, and rust.	Use a different type of seal, clean the housing, and use a clean lubricant.
	Creep.	Insufficient interference or insufficient tightening of sleeve	Modify the fit or tighten the sleeve.
Seizure	Discoloration or welding of raceway, rolling elements, and rib.	Insufficient clearance, incorrect lubrication, or improper mounting.	Review the internal clearance and bearing fit, supply an adequate amount of the proper lubricant and improve the mounting method and related parts.
Electric Burns	Fluting or corrugation.	Melting due to electric arcing.	Install a ground wire to stop flow of electricity or insulate the bearing.
Corrosion and Rust	Rust and corrosion of fitting surfaces and bearing interior.	Condensation of water from the air, fretting, or penetration by corrosive substances.	Use care in storing and avoid high temperatures and high humidity; treatment for rust prevention is necessary when the operation is suspended for a long time.

Introduction

Ball Bearings

Cylindrical Roller Bearings

Spherical Roller Bearings

Tapered Roller Bearings

Thrust Bearings

Split Pillow Blocks

Super Precision Bearings

Linear Motion

Rolling Mill Bearings

Engineering Section

Appendix A –Tolerances for Shaft Diameters

Units: Inch

Shaft Diameter (mm)		Bearing Bore Tolerance	Shaft Tolerance								
over	incl		ABEC1	g6	h6	h9	h10	js5	js6	k5	k6
3	6	+0	-0.0002	+0	+0	+0	+0	±0.0001	±0.0002	+0.0002	+0.0004
		-0.0003	-0.0005	-0.0003	-0.0012	-0.0019				+0	+0
6	10	+0	-0.0002	+0	+0	+0	+0	±0.0001	±0.0002	+0.0003	+0.0004
		-0.0003	-0.0006	-0.0004	-0.0014	-0.0023				+0	+0
10	18	+0	-0.0002	+0	+0	+0	+0	±0.0002	±0.0002	+0.0004	+0.0005
		-0.0003	-0.0007	-0.0004	-0.0017	-0.0028				+0	+0
18	30	+0	-0.0003	+0	+0	+0	+0	±0.0002	±0.0003	+0.0004	+0.0006
		-0.0004	-0.0008	-0.0005	-0.0020	-0.0033				+0.0001	+0.0001
30	50	+0	-0.0004	+0	+0	+0	+0	±0.0002	±0.0003	+0.0005	+0.0007
		-0.0005	-0.0010	-0.0006	-0.0024	-0.0039				+0.0001	+0.0001
50	80	+0	-0.0004	+0	+0	+0	+0	±0.0003	±0.0004	+0.0006	+0.0008
		-0.0006	-0.0011	-0.0007	-0.0029	-0.0047				+0.0001	+0.0001
80	120	+0	-0.0005	+0	+0	+0	+0	±0.0003	±0.0004	+0.0007	+0.0010
		-0.0008	-0.0013	-0.0009	-0.0034	-0.0055				+0.0001	+0.0001
120	180	+0	-0.0006	+0	+0	+0	+0	±0.0004	±0.0005	+0.0008	+0.0011
		-0.0010	-0.0015	-0.0010	-0.0039	-0.0063				+0.0001	+0.0001
180	250	+0	-0.0006	+0	+0	+0	+0	±0.0004	±0.0006	+0.0009	+0.0013
		-0.0012	-0.0017	-0.0011	-0.0045	-0.0073				+0.0002	+0.0002
250	315	+0	-0.0007	+0	+0	+0	+0	±0.0005	±0.0006	+0.0011	+0.0014
		-0.0014	-0.0019	-0.0013	-0.0051	-0.0083				+0.0002	+0.0002
315	400	+0	-0.0007	+0	+0	+0	+0	±0.0005	±0.0007	+0.0011	+0.0016
		-0.0016	-0.0021	-0.0014	-0.0055	-0.0091				+0.0002	+0.0002
400	500	+0	-0.0008	+0	+0	+0	+0	±0.0005	±0.0008	+0.0013	+0.0018
		-0.0018	-0.0024	-0.0016	-0.0061	-0.0098				+0.0002	+0.0002
500	630	+0	-0.0009	+0	+0	+0	+0		±0.0009		+0.0017
		-0.0020	-0.0026	-0.0017	-0.0069	-0.0110					+0
630	800	+0	-0.0009	+0	+0	+0	+0		±0.0010		+0.0020
		-0.0030	-0.0029	-0.0020	-0.0079	-0.0126					+0
800	1000	+0	-0.0010	+0	+0	+0	+0		±0.0011		+0.0022
		-0.0039	-0.0032	-0.0022	-0.0091	-0.0142					+0
1000	1250	+0	-0.0011	+0	+0	+0	+0		±0.0013		+0.0026
		-0.0049	-0.0037	-0.0026	-0.0102	-0.0165					+0
1250	1600	+0	-0.0012	+0	+0	+0	+0		±0.0015		+0.0031
		-0.0063	-0.0043	-0.0031	-0.0122	-0.0197					+0
1600	2000	+0	-0.0013	+0	+0	+0	+0		±0.0018		+0.0036
		-0.0079	-0.0049	-0.0036	-0.0146	-0.0236					+0

Directions: The shaft tolerances are determined by adding the top number in the tolerance group to the shaft size and adding the bottom number to the shaft size. This provides the maximum shaft size and the minimum shaft size, respectively.

For example:

Shaft size = 0.4724”

Application = Electric Motor (Recommended shaft fit js6)

Shaft Tolerance (max) = 0.4724” + 0.0002” = 0.4726”

Shaft Tolerance (min) = 0.4724” - 0.0002” = 0.4722”

Appendix A –Tolerances for Shaft Diameters (continued)

Units: Inch						Units: Inch			
Shaft Diameter (mm)		Shaft Tolerance				Shaft Diameter (inch)		Shaft Tolerance	
over	incl	m5	m6	n6	p6	over	incl	r6	r7
3	6	+0.0004	+0.0005	+0.0006	+0.0008	3	6	+0.0009	+0.0007
		+0.0002	+0.0002	+0.0003	+0.0005			+0.0006	+0.0006
6	10	+0.0005	+0.0006	+0.0007	+0.0009	6	10	+0.0011	+0.0013
		+0.0002	+0.0002	+0.0004	+0.0006			+0.0007	+0.0007
10	18	+0.0006	+0.0007	+0.0009	+0.0011	10	18	+0.0013	+0.0016
		+0.0003	+0.0003	+0.0005	+0.0007			+0.0009	+0.0009
18	30	+0.0007	+0.0008	+0.0011	+0.0014	18	30	+0.0016	+0.0019
		+0.0003	+0.0003	+0.0006	+0.0009			+0.0011	+0.0011
30	50	+0.0008	+0.0010	+0.0013	+0.0017	30	50	+0.0020	+0.0023
		+0.0004	+0.0004	+0.0007	+0.0010			+0.0013	+0.0013
50	80	+0.0009	+0.0012	+0.0015	+0.0020	50	65	+0.0024	+0.0028
		+0.0004	+0.0004	+0.0008	+0.0013			+0.0016	+0.0016
80	120	+0.0011	+0.0014	+0.0018	+0.0023	65	80	+0.0024	+0.0029
		+0.0005	+0.0005	+0.0009	+0.0015			+0.0017	+0.0017
120	180	+0.0013	+0.0016	+0.0020	+0.0027	80	100	+0.0029	+0.0034
		+0.0006	+0.0006	+0.0011	+0.0017			+0.0020	+0.0020
180	250	+0.0015	+0.0018	+0.0024	+0.0031	100	120	+0.0030	+0.0035
		+0.0007	+0.0007	+0.0012	+0.0020			+0.0021	+0.0021
250	315	+0.0017	+0.0020	+0.0026	+0.0035	120	140	+0.0035	+0.0041
		+0.0008	+0.0008	+0.0013	+0.0022			+0.0025	+0.0025
315	400	+0.0018	+0.0022	+0.0029	+0.0039	140	160	+0.0035	+0.0041
		+0.0008	+0.0008	+0.0015	+0.0024			+0.0026	+0.0026
400	500	+0.0020	+0.0025	+0.0031	+0.0043	160	180	+0.0037	+0.0043
		+0.0009	+0.0009	+0.0016	+0.0027			+0.0027	+0.0027
500	630		+0.0028	+0.0035	+0.0048	180	200	+0.0042	+0.0048
			+0.0010	+0.0017	+0.0031			+0.0030	+0.0030
630	800		+0.0031	+0.0039	+0.0054	200	225	+0.0043	+0.0050
			+0.0012	+0.0020	+0.0035			+0.0031	+0.0031
800	1000		+0.0035	+0.0044	+0.0061	225	250	+0.0044	+0.0051
			+0.0013	+0.0022	+0.0039			+0.0033	+0.0033
1000	1250		+0.0042	+0.0052	+0.0073	250	280	+0.0050	+0.0057
			+0.0016	+0.0026	+0.0047			+0.0037	+0.0037
1250	1600		+0.0050	+0.0061	+0.0086	280	315	+0.0051	+0.0059
			+0.0019	+0.0031	+0.0055			+0.0039	+0.0039
1600	2000		+0.0059	+0.0072	+0.0103	315	355	+0.0057	+0.0065
			+0.0023	+0.0036	+0.0067			+0.0043	+0.0043
						355	400	+0.0059	+0.0067
								+0.0045	+0.0045
						400	450	+0.0065	+0.0074
								+0.0050	+0.0050
						450	500	+0.0068	+0.0077
								+0.0052	+0.0052
						500	560	+0.0076	+0.0087
								+0.0059	+0.0059
						560	630	+0.0078	+0.0089
								+0.0061	+0.0061
						630	710	+0.0089	+0.0100
								+0.0069	+0.0069
						710	800	+0.0093	+0.0104
								+0.0073	+0.0073
						800	900	+0.0105	+0.0118
								+0.0083	+0.0083
						900	1000	+0.0109	+0.0122
								+0.0087	+0.0087
						1000	1120	+0.0124	+0.0140
								+0.0098	+0.0098
						1120	1250	+0.0128	+0.0144
								+0.0102	+0.0102
						1250	1400	+0.0149	+0.0167
								+0.0118	+0.0118
						1400	1600	+0.0161	+0.0179
								+0.0130	+0.0130
						1600	1800	+0.0182	+0.0205
								+0.0146	+0.0146
						1800	2000	+0.0194	+0.0217
								+0.0157	+0.0157

Introduction
Ball Bearings
Cylindrical Roller Bearings
Spherical Roller Bearings
Tapered Roller Bearings
Thrust Bearings
Split Pillow Blocks
Super Precision Bearings
Linear Motion
Rolling Mill Bearings
Engineering Section

Appendix B – Tolerances for Housing Bore Diameters

Units: Inch

	Housing Bore Diameter (mm)		Bearing O.D. Tolerance	Housing Bore Tolerance						
	over	incl		ABEC1	G7	H6	H7	H8	J6	J7
Ball Bearings	10	18	+0	+0.0009	+0.0004	+0.0007	+0.0011	+0.0002	+0.0004	±0.0002
			-0.0003	+0.0002	+0	+0	+0	-0.0002	-0.0003	
Ball Bearings	18	30	+0	+0.0011	+0.0005	+0.0008	+0.0013	+0.0003	+0.0005	±0.0003
			-0.0004	+0.0003	+0	+0	+0	-0.0002	-0.0004	
Cylindrical Roller Bearings	30	50	+0	+0.0013	+0.0006	+0.0010	+0.0015	+0.0004	+0.0006	±0.0003
			-0.0004	+0.0004	+0	+0	+0	-0.0002	-0.0004	
Cylindrical Roller Bearings	50	80	+0	+0.0016	+0.0007	+0.0012	+0.0018	+0.0005	+0.0007	±0.0004
			-0.0005	+0.0004	+0	+0	+0	-0.0002	-0.0005	
Cylindrical Roller Bearings	80	120	+0	+0.0019	+0.0009	+0.0014	+0.0021	+0.0006	+0.0009	±0.0004
			-0.0006	+0.0005	+0	+0	+0	-0.0002	-0.0005	
Cylindrical Roller Bearings	120	150	+0	+0.0021	+0.0010	+0.0016	+0.0025	+0.0007	+0.0010	±0.0005
			-0.0007	+0.0006	+0	+0	+0	-0.0003	-0.0006	
Spherical Roller Bearings	150	180	+0	+0.0021	+0.0010	+0.0016	+0.0025	+0.0007	+0.0010	±0.0005
			-0.0010	+0.0006	+0	+0	+0	-0.0003	-0.0006	
Spherical Roller Bearings	180	250	+0	+0.0024	+0.0011	+0.0018	+0.0028	+0.0009	+0.0012	±0.0006
			-0.0012	+0.0006	+0	+0	+0	-0.0003	-0.0006	
Spherical Roller Bearings	250	315	+0	+0.0027	+0.0013	+0.0020	+0.0032	+0.0010	+0.0014	±0.0006
			-0.0014	+0.0007	+0	+0	+0	-0.0003	-0.0006	
Spherical Roller Bearings	315	400	+0	+0.0030	+0.0014	+0.0022	+0.0035	+0.0011	+0.0015	±0.0007
			-0.0016	+0.0007	+0	+0	+0	-0.0003	-0.0007	
Tapered Roller Bearings	400	500	+0	+0.0033	+0.0016	+0.0025	+0.0038	+0.0013	+0.0017	±0.0008
			-0.0018	+0.0008	+0	+0	+0	-0.0003	-0.0008	
Tapered Roller Bearings	500	630	+0	+0.0036	+0.0017	+0.0028	+0.0043	-	-	±0.0009
			-0.0020	+0.0009	+0	+0	+0	-	-	
Tapered Roller Bearings	630	800	+0	+0.0041	+0.0020	+0.0031	+0.0049	-	-	±0.0010
			-0.0030	+0.0009	+0	+0	+0	-	-	
Thrust Bearings	800	1000	+0	+0.0046	+0.0022	+0.0035	+0.0055	-	-	±0.0011
			-0.0039	+0.0010	+0	+0	+0	-	-	
Thrust Bearings	1000	1250	+0	+0.0052	+0.0026	+0.0041	+0.0065	-	-	±0.0013
			-0.0049	+0.0011	+0	+0	+0	-	-	
Thrust Bearings	1250	1600	+0	+0.0061	+0.0031	+0.0049	+0.0077	-	-	±0.0015
			-0.0063	+0.0012	+0	+0	+0	-	-	
Thrust Bearings	1600	2000	+0	+0.0072	+0.0036	+0.0059	+0.0091	-	-	±0.0018
			-0.0079	+0.0013	+0	+0	+0	-	-	
Split Pillow Blocks	2000	2500	+0	+0.0082	+0.0043	+0.0069	+0.0110	-	-	±0.0022
			-0.0098	+0.0013	+0	+0	+0	-	-	

Directions: The housing bore tolerances are determined by adding the top number in the tolerance group to the housing bore size and adding the bottom number to the housing bore size. This provides the maximum and minimum housing bore, respectively.

For example:

Housing bore = 1.2598”

Application = Electric Motor (Recommended Housing fit H7)

Housing Bore Tolerance (max) = 1.2598” + 0.0007” = 1.2605”

Housing Bore Tolerance (min) = 1.2598” + 0” = 1.2598”

Appendix B – Tolerances for Housing Bore Diameters (continued)

Units: Inch

Housing Bore Diameter (mm)		Housing Bore Tolerance							
over	incl	JS7	K6	K7	M6	M7	N6	N7	P7
10	18	±0.0004	+0.0001 -0.0004	+0.0002 -0.0005	-0.0002 -0.0006	+0 -0.0007	-0.0004 -0.0008	-0.0002 -0.0009	-0.0004 -0.0011
18	30	±0.0004	+0.0001 -0.0004	+0.0002 -0.0006	-0.0002 -0.0007	+0 -0.0008	-0.0004 -0.0009	-0.0003 -0.0011	-0.0006 -0.0014
30	50	±0.0005	+0.0001 -0.0005	+0.0003 -0.0007	-0.0002 -0.0008	+0 -0.0010	-0.0005 -0.0011	-0.0003 -0.0013	-0.0007 -0.0017
50	80	±0.0006	+0.0002 -0.0006	+0.0004 -0.0008	-0.0002 -0.0009	+0 -0.0012	-0.0006 -0.0013	-0.0004 -0.0015	-0.0008 -0.0020
80	120	±0.0007	+0.0002 -0.0007	+0.0004 -0.0010	-0.0002 -0.0011	+0 -0.0014	-0.0006 -0.0015	-0.0004 -0.0018	-0.0009 -0.0023
120	180	±0.0008	+0.0002 -0.0008	+0.0005 -0.0011	-0.0003 -0.0013	+0 -0.0016	-0.0008 -0.0018	-0.0005 -0.0020	-0.0011 -0.0027
180	250	±0.0009	+0.0002 -0.0009	+0.0005 -0.0013	-0.0003 -0.0015	+0 -0.0018	-0.0009 -0.0020	-0.0006 -0.0024	-0.0013 -0.0031
250	315	±0.0010	+0.0002 -0.0011	+0.0006 -0.0014	-0.0004 -0.0016	+0 -0.0020	-0.0010 -0.0022	-0.0006 -0.0026	-0.0014 -0.0035
315	400	±0.0011	+0.0003 -0.0011	+0.0007 -0.0016	-0.0004 -0.0018	+0 -0.0022	-0.0010 -0.0024	-0.0006 -0.0029	-0.0016 -0.0039
400	500	±0.0012	+0.0003 -0.0013	+0.0007 -0.0018	-0.0004 -0.0020	+0 -0.0025	-0.0011 -0.0026	-0.0007 -0.0031	-0.0018 -0.0043
500	630	±0.0014	+0 -0.0017	+0 -0.0028	-0.0010 -0.0028	-0.0010 -0.0038	-0.0017 -0.0035	-0.0017 -0.0045	-0.0031 -0.0058
630	800	±0.0016	+0 -0.0020	+0 -0.0031	-0.0012 -0.0031	-0.0012 -0.0043	-0.0020 -0.0039	-0.0020 -0.0051	-0.0035 -0.0066
800	1000	±0.0018	+0 -0.0022	+0 -0.0035	-0.0013 -0.0035	-0.0013 -0.0049	-0.0022 -0.0044	-0.0022 -0.0057	-0.0039 -0.0075
1000	1250	±0.0020	+0 -0.0026	+0 -0.0041	-0.0016 -0.0042	-0.0016 -0.0057	-0.0026 -0.0052	-0.0026 -0.0067	-0.0047 -0.0089
1250	1600	±0.0024	+0 -0.0031	+0 -0.0049	-0.0019 -0.0050	-0.0019 -0.0068	-0.0031 -0.0061	-0.0031 -0.0080	-0.0055 -0.0104
1600	2000	±0.0030	+0 -0.0036	+0 -0.0059	-0.0023 -0.0059	-0.0023 -0.0082	-0.0036 -0.0072	-0.0036 -0.0095	-0.0067 -0.0126
2000	2500	±0.0034	+0 -0.0043	+0 -0.0069	-0.0027 -0.0070	-0.0027 -0.0096	-0.0043 -0.0087	-0.0043 -0.0112	-0.0077 -0.0146

Introduction

Ball Bearings

Cylindrical Roller Bearings

Spherical Roller Bearings

Tapered Roller Bearings

Thrust Bearings

Split Pillow Blocks

Super Precision Bearings

Linear Motion

Rolling Mill Bearings

Engineering Section

NSK NSK NSK NSK NSK NSK NSK NSK

Introduction	Bearing No.			Bearing No.			Bearing No.			Bearing No.		
	(prefix, no., Suffix)	Section	Page	(prefix, no., Suffix)	Section	Page	(prefix, no., Suffix)	Section	Page	(prefix, no., Suffix)	Section	Page
Ball Bearings	2PSL240-1UPA	Spherical	99	90BNC10SN24	Precision	204	493	Tapered	136	2314	Ball Bearings	28
	2SL180-2UPA	Spherical	68	90BNR10H	Precision	208	495	Tapered	136	2315	Ball Bearings	28
	2SL180-2UPA	Spherical	99	90BNR10S	Precision	206	497	Tapered	136	2316	Ball Bearings	28
	2SL200-2UPA	Spherical	68	90BTR10S	Precision	216	552A	Tapered	136	2720	Tapered	134
	2SL200-2UPA	Spherical	99	95BAR10S	Precision	214	553X	Tapered	136	2729	Tapered	134
	2SL220-2UPA	Spherical	68	95BNC10	Precision	202	560	Tapered	136	2788	Tapered	134
	2SL220-2UPA	Spherical	99	95BNC10SN24	Precision	204	560	Tapered	136	2788	Tapered	134
	2SL240-2UPA	Spherical	68	95BNR10H	Precision	208	563	Tapered	136	3200X	Ball Bearings	30
	2SL240-2UPA	Spherical	99	95BNR10S	Precision	206	567	Tapered	136	3201J	Ball Bearings	30
	2SL260-2UPA	Spherical	68	95BTR10S	Precision	216	572	Tapered	136	3202J	Ball Bearings	30
	2SL260-2UPA	Spherical	99	100BAR10S	Precision	214	572	Tapered	136	3203J	Ball Bearings	30
Cylindrical Roller Bearings	2SL280-2UPA	Spherical	68	100BNC10	Precision	202	575	Tapered	136	3204J	Ball Bearings	30
	2SL280-2UPA	Spherical	99	100BNC10SN24	Precision	204	580	Tapered	136	3205J	Ball Bearings	30
	2SL300-2UPA	Spherical	68	100BNR10H	Precision	208	592A	Tapered	136	3206J	Ball Bearings	30
	2SL300-2UPA	Spherical	99	100BNR10S	Precision	206	592A	Tapered	136	3207J	Ball Bearings	30
	2SL320-2UPA	Spherical	68	100BTR10S	Precision	216	592A	Tapered	136	3208J	Ball Bearings	30
	2SL320-2UPA	Spherical	99	101TAC145B	Precision	224	593	Tapered	136	3209J	Ball Bearings	30
	2SL340-2UPA	Spherical	68	105BAR10S	Precision	214	598	Tapered	136	3210J	Ball Bearings	30
	2SL340-2UPA	Spherical	99	105BNC10	Precision	202	598A	Tapered	136	3211J	Ball Bearings	30
	6BGR10H	Precision	212	105BNC10SN24	Precision	204	604	Ball Bearings	13	3212J	Ball Bearings	30
	7BGR10S	Precision	210	105BTR10S	Precision	212	605	Ball Bearings	13	3213J	Ball Bearings	30
	7BGR10S	Precision	212	110BAR10S	Precision	214	606	Ball Bearings	13	3214J	Ball Bearings	30
Spherical Roller Bearings	8BGR10S	Precision	210	110BNC10	Precision	202	607	Ball Bearings	13	3302J	Ball Bearings	30
	8BGR10H	Precision	212	110BNC10SN24	Precision	204	608	Ball Bearings	13	3303J	Ball Bearings	30
	8BGR10S	Precision	210	110BTR10S	Precision	216	608-5	Ball Bearings	13	3304J	Ball Bearings	30
	10BGR10H	Precision	212	120BAR10S	Precision	214	609	Ball Bearings	13	3305J	Ball Bearings	30
	10BGR10S	Precision	210	120BTR10S	Precision	216	623	Ball Bearings	13	3306J	Ball Bearings	30
	12BGR10H	Precision	212	130BAR10S	Precision	214	624	Ball Bearings	13	3307J	Ball Bearings	30
	12BGR10S	Precision	210	130BTR10S	Precision	216	625	Ball Bearings	13	3308J	Ball Bearings	30
	15BGR10H	Precision	212	230/1000CAME4	Spherical	80	626	Ball Bearings	13	3309J	Ball Bearings	30
	15BGR10S	Precision	210	230/1060CAME4	Spherical	80	627	Ball Bearings	13	3310J	Ball Bearings	30
	17BGR10H	Precision	212	230/1120CAME4	Spherical	80	628	Ball Bearings	13	3311J	Ball Bearings	30
	Tapered Roller Bearings	17BGR10S	Precision	210	230/1250CAME4	Spherical	80	629	Ball Bearings	13	3312J	Ball Bearings
20BGR10H		Precision	224	230/500CAME4	Spherical	80	634	Ball Bearings	13	3313J	Ball Bearings	30
20BGR10S		Precision	212	230/530CAME4	Spherical	80	635	Ball Bearings	13	3314J	Ball Bearings	30
20TAC47B		Precision	224	230/560CAME4	Spherical	80	638	Ball Bearings	13	3525	Tapered	134
23TAC62B		Precision	224	230/600CAME4	Spherical	80	653	Tapered	136	3578	Tapered	134
25BGR10H		Precision	212	230/630CAME4	Spherical	80	653	Tapered	136	3720	Tapered	134
25BGR10S		Precision	210	230/670CAME4	Spherical	80	663	Tapered	136	3782	Tapered	134
25TAC62B		Precision	224	230/710CAME4	Spherical	80	665A	Tapered	136	3920	Tapered	136
30BNC10		Precision	202	230/750CAME4	Spherical	80	684	Ball Bearings	13	3920	Tapered	136
30BNC10SN24		Precision	204	230/800CAME4	Spherical	80	684ZZW	Ball Bearings	13	3982	Tapered	136
Thrust Bearings		30BNR10H	Precision	208	230/850CAME4	Spherical	80	685	Ball Bearings	13	3984	Tapered
	30BNR10S	Precision	206	230/900CAME4	Spherical	80	685ZZW	Ball Bearings	13	05075	Tapered	132
	30TAC62B	Precision	224	230/950CAME4	Spherical	80	686	Ball Bearings	13	05079	Tapered	132
	35BNC10	Precision	202	231/500CAME4	Spherical	84	686ZZW	Ball Bearings	13	05185	Tapered	132
	35BNC10SN24	Precision	204	231/530CAME4	Spherical	84	687	Ball Bearings	13	05185	Tapered	132
	35BNR10H	Precision	208	231/560CAME4	Spherical	84	687ZZW	Ball Bearings	13	5200J	Ball Bearings	32
	35BNR10S	Precision	206	231/600CAME4	Spherical	84	689	Ball Bearings	13	5200TNG	Ball Bearings	32
	35TAC62B	Precision	224	231/630CAME4	Spherical	84	689ZZW	Ball Bearings	13	5201J	Ball Bearings	32
	38TAC72B	Precision	224	231/670CAME4	Spherical	84	693	Ball Bearings	13	5201TNG	Ball Bearings	32
	40BD49V	Ball Bearings	44	231/710CAME4	Spherical	84	693ZZW	Ball Bearings	13	5202J	Ball Bearings	32
	Split Pillow Blocks	40BNC10	Precision	202	231/750CAME4	Spherical	84	694	Ball Bearings	13	5202TNG	Ball Bearings
40BNC10SN24		Precision	204	231/800CAME4	Spherical	84	695	Ball Bearings	13	5203J	Ball Bearings	32
40BNR10H		Precision	208	231/850CAME4	Spherical	84	696	Ball Bearings	13	5203TNG	Ball Bearings	32
40BNR10S		Precision	206	231/900CAME4	Spherical	84	697	Ball Bearings	13	5204J	Ball Bearings	32
40TAC72B		Precision	224	232/500CAME4	Spherical	88	698	Ball Bearings	13	5204TNG	Ball Bearings	32
40TAC90B		Precision	224	232/530CAME4	Spherical	88	742	Tapered	136	5205J	Ball Bearings	32
44TAC76B		Precision	224	232/560CAME4	Spherical	88	749	Tapered	136	5205TNG	Ball Bearings	32
45BNC10		Precision	202	232/600CAME4	Spherical	88	1200	Ball Bearings	26	5206J	Ball Bearings	32
45BNC10SN24		Precision	204	232/630CAME4	Spherical	88	1201	Ball Bearings	26	5206TNG	Ball Bearings	32
45BNR10H		Precision	208	232/670CAME4	Spherical	88	1202	Ball Bearings	26	5207J	Ball Bearings	32
Super Precision Bearings		45BNR10S	Precision	206	232/710CAME4	Spherical	88	1203	Ball Bearings	26	5207TNG	Ball Bearings
	45BTR10H	Precision	208	232/750CAME4	Spherical	88	1204	Ball Bearings	26	5208J	Ball Bearings	32
	45BTR10S	Precision	206	232/800CAME4	Spherical	88	1205	Ball Bearings	26	5208TNG	Ball Bearings	32
	45TAC100B	Precision	224	232/850CAME4	Spherical	88	1206	Ball Bearings	26	5209J	Ball Bearings	34
	45TAC75B	Precision	224	232/900CAME4	Spherical	88	1207	Ball Bearings	26	5209TNG	Ball Bearings	34
	50BNC10	Precision	202	232/950CAME4	Spherical	88	1207	Ball Bearings	26	5210J	Ball Bearings	34
	50BNC10SN24	Precision	204	239/1000CAME4	Spherical	90	1208	Ball Bearings	26	5210TNG	Ball Bearings	34
	50BNR10H	Precision	208	239/1060CAME4	Spherical	90	1209	Ball Bearings	26	5211J	Ball Bearings	34
	50BNR10S	Precision	206	239/1120CAME4	Spherical	90	1210	Ball Bearings	26	5211TNG	Ball Bearings	34
	50TAC100B	Precision	224	239/1180CAME4	Spherical	90	1211	Ball Bearings	26	5212J	Ball Bearings	34
	55BNC10	Precision	202	239/1250CAME4	Spherical	90	1212	Ball Bearings	26	5212TNG	Ball Bearings	34
Linear Motion	55BNC10SN24	Precision	204	239/1400CAME4	Spherical	90	1213	Ball Bearings	26	5213J	Ball Bearings	34
	55BNR10H	Precision	208	239/500CAME4	Spherical	90	1214	Ball Bearings	26	5213TNG	Ball Bearings	34
	55BNR10S	Precision	206	239/530CAME4	Spherical	90	1215	Ball Bearings	26	5214J	Ball Bearings	34
	55TAC100B	Precision	224	239/560CAME4	Spherical	90	1301	Ball Bearings	26	5214TNG	Ball Bearings	34
	55TAC120B	Precision	224	239/600CAME4	Spherical	90	1302	Ball Bearings	26	5215J	Ball Bearings	34
	57TAC90B	Precision	224	239/630CAME4	Spherical	90	1303	Ball Bearings	26	5216J	Ball Bearings	34
	60BAR10S	Precision	214	239/670CAME4	Spherical	90	1304	Ball Bearings	26	5217J	Ball Bearings	34
	60BNC10	Precision	202	239/710CAME4	Spherical	90	1305	Ball Bearings	26	5302TNG	Ball Bearings	32
	60BNC10SN24	Precision	204	239/750CAME4	Spherical	90	1306	Ball Bearings	26	5303J	Ball Bearings	32
	60BNR10H	Precision	208	239/800CAME4	Spherical	90	1307	Ball Bearings	26	5303TNG	Ball Bearings	32
	Rolling Mill Bearings	60BNR10S	Precision	206	239/850CAME4	Spherical	90	1308	Ball Bearings	26	5304J	Ball Bearings
60BTR10S		Precision	216	239/900CAME4	Spherical	90	1309	Ball Bearings	26	5304TNG	Ball Bearings	32
60TAC120B		Precision	224	239/950CAME4	Spherical	90	1310	Ball Bearings	26	5305J	Ball Bearings	32
65BAR10S		Precision	214	240/1000CAME4	Spherical	92	1311	Ball Bearings	26	5305TNG	Ball Bearings	32
65BNC10		Precision	202	240/1120CAME4	Spherical	92	1312	Ball Bearings	26	5306J	Ball Bearings	32
65BNC10SN24		Precision	204	240/1250CAME4	Spherical	92	1313	Ball Bearings	26	5306TNG	Ball Bearings	32
65BNR10H		Precision	208	240/1320CAME4	Spherical	92	1314	Ball Bearings	26	5307J	Ball Bearings	32
65BNR10S		Precision	206	240/1400CAME4	Spherical	92	1315	Ball Bearings	26	5307TNG	Ball Bearings	32
65BTR10S		Precision	216	240/500CAME4	Spherical	92	2200	Ball Bearings	28	5308J	Ball Bearings	32
70BAR10S		Precision	214	240/530CAME4	Spherical	92	2201	Ball Bearings	28	5308TNG	Ball Bearings	32
Engineering Section		70BNC10	Precision	202	240/560CAME4	Spherical	92	2202	Ball Bearings	28	5309J	Ball Bearings
	70BNC10SN24	Precision	204	240/600CAME4	Spherical	92	2203	Ball Bearings	28	5309TNG	Ball Bearings	34
	70BNR10H	Precision	208	240/630CAME4	Spherical	92	2204	Ball Bearings	28	5310J	Ball Bearings	34
	70BNR10S	Precision	206	240/670CAME4	Spherical	92	2205	Ball Bearings	28	5310TNG	Ball Bearings	34
	70BTR10S	Precision	216	240/710CAME4	Spherical	92	2206	Ball Bearings	28	5311J	Ball Bearings	34
	75BAR10S	Precision	214	240/800CAME4	Spherical	92	2207	Ball Bearings	28	5311TNG	Ball Bearings	34
	75BNC10	Precision	202	240/850CAME4	Spherical	92	2208	Ball Bearings	28			

NSK NSK NSK NSK NSK NSK NSK NSK

Bearing No.			Bearing No.			Bearing No.			Bearing No.		
(prefix, no., Suffix)	Section	Page	(prefix, no., Suffix)	Section	Page	(prefix, no., Suffix)	Section	Page	(prefix, no., Suffix)	Section	Page
6015	Ball Bearings	14	6902	Ball Bearings	22	7205A5	Precision	196	7411B	Ball Bearings	40
6016	Ball Bearings	14	6903	Ball Bearings	22	7205B	Ball Bearings	36	7412B	Ball Bearings	40
6017	Ball Bearings	14	6904	Ball Bearings	22	7205C	Precision	194	7413B	Ball Bearings	40
6018	Ball Bearings	14	6905	Ball Bearings	22	7206A5	Precision	196	7414B	Ball Bearings	40
6019	Ball Bearings	14	6906	Ball Bearings	22	7206B	Ball Bearings	36	7415B	Ball Bearings	40
6020	Ball Bearings	14	6907	Ball Bearings	22	7206C	Precision	194	7416B	Ball Bearings	40
6021	Ball Bearings	14	6908	Ball Bearings	22	7207A5	Precision	196	7420B	Ball Bearings	40
6022	Ball Bearings	14	6909	Ball Bearings	22	7207B	Ball Bearings	36	7900A5	Precision	200
6024	Ball Bearings	14	6910	Ball Bearings	22	7207C	Precision	194	7900C	Precision	198
6026	Ball Bearings	14	6911	Ball Bearings	22	7208A5	Precision	196	7901A5	Precision	200
6028	Ball Bearings	14	6912	Ball Bearings	22	7208B	Ball Bearings	36	7901C	Precision	198
6030	Ball Bearings	14	6913	Ball Bearings	22	7208C	Precision	194	7902A5	Precision	200
6032	Ball Bearings	14	6914	Ball Bearings	22	7209A5	Precision	196	7902C	Precision	198
6034	Ball Bearings	14	6915	Ball Bearings	22	7209B	Ball Bearings	36	7903A5	Precision	200
6036	Ball Bearings	14	6916	Ball Bearings	22	7209C	Precision	194	7903C	Precision	198
6038	Ball Bearings	14	6917	Ball Bearings	22	7210A5	Precision	196	7904A5	Precision	200
6040	Ball Bearings	14	6918	Ball Bearings	22	7210B	Ball Bearings	36	7904C	Precision	198
6200	Ball Bearings	16	6919	Ball Bearings	22	7210C	Precision	194	7905A5	Precision	200
6201	Ball Bearings	16	6920	Ball Bearings	22	7211A5	Precision	196	7905C	Precision	198
6201-08	Ball Bearings	16	6921	Ball Bearings	22	7211B	Ball Bearings	36	7906A5	Precision	200
6201-13M	Ball Bearings	16	6922	Ball Bearings	22	7211C	Precision	194	7906C	Precision	198
6202	Ball Bearings	16	6924	Ball Bearings	22	7212A5	Precision	196	7907A5	Precision	200
6202-10	Ball Bearings	16	6926	Ball Bearings	22	7212B	Ball Bearings	36	7907C	Precision	198
6202-16M	Ball Bearings	16	6928	Ball Bearings	22	7212C	Precision	194	7908A5	Precision	200
6203	Ball Bearings	16	6930	Ball Bearings	22	7213A5	Precision	196	7908C	Precision	198
6203-625	Ball Bearings	16	6932	Ball Bearings	22	7213B	Ball Bearings	36	7909A5	Precision	200
6204	Ball Bearings	16	6934	Ball Bearings	22	7213C	Precision	194	7909C	Precision	198
6205	Ball Bearings	16	6936	Ball Bearings	22	7214A5	Precision	196	7910A5	Precision	200
6206	Ball Bearings	16	6938	Ball Bearings	22	7214B	Ball Bearings	36	7910C	Precision	198
6207	Ball Bearings	16	6940	Ball Bearings	22	7214C	Precision	194	7911A5	Precision	200
6208	Ball Bearings	16	7000A5	Precision	192	7215A5	Precision	196	7911C	Precision	198
6209	Ball Bearings	16	7000C	Precision	190	7215B	Ball Bearings	36	7912A5	Precision	200
6210	Ball Bearings	16	7001A5	Precision	192	7215C	Precision	194	7912C	Precision	198
6211	Ball Bearings	16	7001C	Precision	190	7216A5	Precision	196	7913A5	Precision	200
6212	Ball Bearings	16	7002A5	Precision	192	7216B	Ball Bearings	36	7913C	Precision	198
6213	Ball Bearings	16	7002C	Precision	190	7216C	Precision	194	7914A5	Precision	200
6214	Ball Bearings	16	7003A5	Precision	192	7217A5	Precision	196	7914C	Precision	198
6215	Ball Bearings	16	7003C	Precision	190	7217B	Ball Bearings	36	7915A5	Precision	200
6216	Ball Bearings	16	7004A5	Precision	192	7217C	Precision	194	7915C	Precision	198
6217	Ball Bearings	16	7004C	Precision	190	7218A5	Precision	196	7916A5	Precision	200
6218	Ball Bearings	16	7005A5	Precision	192	7218B	Ball Bearings	36	7916C	Precision	198
6219	Ball Bearings	16	7005C	Precision	190	7218C	Precision	194	7917A5	Precision	200
6220	Ball Bearings	16	7006A5	Precision	192	7219A5	Precision	196	7917C	Precision	198
6221	Ball Bearings	16	7006C	Precision	190	7219B	Ball Bearings	36	7918A5	Precision	200
6222	Ball Bearings	16	7007A5	Precision	192	7219C	Precision	194	7918C	Precision	198
6224	Ball Bearings	16	7007C	Precision	190	7220A5	Precision	196	7919A5	Precision	200
6226	Ball Bearings	16	7008A5	Precision	192	7220B	Ball Bearings	36	7919C	Precision	198
6228	Ball Bearings	16	7008C	Precision	190	7220C	Precision	194	7920A5	Precision	200
6230	Ball Bearings	16	7009A5	Precision	192	7221A5	Precision	196	7920C	Precision	198
6232	Ball Bearings	16	7009C	Precision	190	7221B	Ball Bearings	36	7921A5	Precision	200
6234	Ball Bearings	16	7010A5	Precision	192	7221C	Precision	194	7921C	Precision	198
6236	Ball Bearings	16	7010C	Precision	190	7222A5	Precision	196	7922A5	Precision	200
6238	Ball Bearings	16	7011A5	Precision	192	7222B	Ball Bearings	36	7922C	Precision	198
6300	Ball Bearings	18	7011C	Precision	190	7222C	Precision	194	7924A5	Precision	200
6301	Ball Bearings	18	7012A5	Precision	192	7224A5	Precision	196	7924C	Precision	198
6302	Ball Bearings	18	7012C	Precision	190	7224B	Ball Bearings	36	7926A5	Precision	200
6303	Ball Bearings	18	7013A5	Precision	192	7224C	Precision	194	7926C	Precision	198
6304	Ball Bearings	18	7013C	Precision	190	7226A5	Precision	196	7928A5	Precision	200
6305	Ball Bearings	18	7014A5	Precision	192	7226B	Ball Bearings	36	7928C	Precision	198
6306	Ball Bearings	18	7014C	Precision	190	7226C	Precision	194	7930A5	Precision	200
6307	Ball Bearings	18	7015A5	Precision	192	7228A5	Precision	196	7930C	Precision	198
6308	Ball Bearings	18	7015C	Precision	190	7228B	Ball Bearings	36	7932A5	Precision	200
6309	Ball Bearings	18	7016A5	Precision	192	7228C	Precision	194	7932C	Precision	198
6310	Ball Bearings	18	7016C	Precision	190	7230A5	Precision	196	7934A5	Precision	200
6311	Ball Bearings	18	7017A5	Precision	192	7230B	Ball Bearings	36	7934C	Precision	198
6312	Ball Bearings	18	7017C	Precision	190	7230C	Precision	194	7936A5	Precision	200
6313	Ball Bearings	18	7018A5	Precision	192	7232A5	Precision	196	7936C	Precision	198
6314	Ball Bearings	18	7018C	Precision	190	7232B	Ball Bearings	36	7938A5	Precision	200
6315	Ball Bearings	18	7019A5	Precision	192	7232C	Precision	194	7938C	Precision	198
6316	Ball Bearings	18	7019C	Precision	190	7234A5	Precision	196	7940A5	Precision	200
6317	Ball Bearings	18	7020A5	Precision	192	7234B	Ball Bearings	36	7940C	Precision	198
6318	Ball Bearings	18	7020C	Precision	190	7234C	Precision	194	09067	Tapered	132
6319	Ball Bearings	18	7021A5	Precision	192	7236A5	Precision	196	09067	Tapered	132
6320	Ball Bearings	18	7021C	Precision	190	7236B	Ball Bearings	36	09074	Tapered	132
6321	Ball Bearings	18	7022A5	Precision	192	7236C	Precision	194	09078	Tapered	132
6322	Ball Bearings	18	7022C	Precision	190	7238A5	Precision	196	09194	Tapered	132
6324	Ball Bearings	18	7024A5	Precision	192	7238B	Ball Bearings	36	09195	Tapered	132
6326	Ball Bearings	18	7024C	Precision	190	7238C	Precision	194	09195	Tapered	132
6328	Ball Bearings	18	7026A5	Precision	192	7240A5	Precision	196	09196	Tapered	132
6330	Ball Bearings	18	7026C	Precision	190	7240B	Ball Bearings	36	11520	Tapered	132
6332	Ball Bearings	18	7028A5	Precision	192	7240C	Precision	194	11590	Tapered	132
6334	Ball Bearings	18	7028C	Precision	190	7300B	Ball Bearings	38	14123A	Tapered	134
6336	Ball Bearings	18	7030A5	Precision	192	7301B	Ball Bearings	38	14125A	Tapered	134
6338	Ball Bearings	18	7030C	Precision	190	7302B	Ball Bearings	38	14130	Tapered	134
6340	Ball Bearings	18	7032A5	Precision	192	7303B	Ball Bearings	38	14136A	Tapered	134
6800	Ball Bearings	20	7032C	Precision	190	7304B	Ball Bearings	38	14137A	Tapered	134
6801	Ball Bearings	20	7034A5	Precision	192	7305B	Ball Bearings	38	14138A	Tapered	134
6802	Ball Bearings	20	7034C	Precision	190	7306B	Ball Bearings	38	14274	Tapered	134
6803	Ball Bearings	20	7036A5	Precision	192	7307B	Ball Bearings	38	14274	Tapered	134
6804	Ball Bearings	20	7036C	Precision	190	7308B	Ball Bearings	38	14276	Tapered	134
6805	Ball Bearings	20	7038A5	Precision	192	7309B	Ball Bearings	38	14276	Tapered	134
6806	Ball Bearings	20	7038C	Precision	190	7310B	Ball Bearings	38	14276	Tapered	134
6807	Ball Bearings	20	7040A5	Precision	192	7311B	Ball Bearings	38	14276	Tapered	134
6808	Ball Bearings	20	7040C	Precision	190	7312B	Ball Bearings	38	15100	Tapered	132
6809	Ball Bearings	20	07087	Tapered	132	7313B	Ball Bearings	38	15101	Tapered	132
6810	Ball Bearings	20	07097	Tapered	132	7314B	Ball Bearings	38	15117	Tapered	132
6811	Ball Bearings	20	07097	Tapered	132	7315B	Ball Bearings	38	15117	Tapered	132
6812	Ball Bearings	20	07098	Tapered	132	7316B	Ball Bearings	38	15118	Tapered	132
6813	Ball Bearings	20	07100	Tapered	132	7317B	Ball Bearings	38	15123	Tapered	134
6814	Ball Bearings	20	07196	Tapered	132	7318B	Ball Bearings	38	15125	Tapered	134
6815	Ball Bearings	20	07196	Tapered	132	7319B	Ball Bearings	38	15126	Tapered	134
6816	Ball Bearings	20	07198	Tapered	132	7320B	Ball Bearings	38	15126	Tapered	134
6817	Ball Bearings	20	7200A5	Precision	196	7321B	Ball Bearings	38	15245	Tapered	132
6818	Ball Bearings	20	7200B	Ball Bearings	36	7322B	Ball Bearings	38	15245	Tapered	132
6819	Ball Bearings	20	7200C	Precision	194	7324B	Ball Bearings	38	15245	Tapered	132
6820	Ball Bearings	20	7201A5	Precision	196	7326B	Ball Bearings	38	15245	Tapered	134
6821	Ball Bearings	20	7201B	Ball Bearings	36	7328B	Ball Bearings	38	15245	Tapered	134
6822	Ball Bearings	20	7201C	Precision	194	7330B	Ball Bearings	38	15245	Tapered	134
6824	Ball Bearings	20	7202A5	Precision	196	7332B	Ball Bearings	38	15250	Tapered	132
6826	Ball Bearings	20	7202B	Ball Bearings	36	7334B	Ball Bearings	38	15250	Tapered	134
6828	Ball Bearings	20	7202C	Precision	194	7336B	Ball Bearings	38	15250X	Tapered	132
6830	Ball Bearings	20	7203A5	Precision	196	7338B	Ball Bearings	38	18520	Tapered	134
6832	Ball Bearings	20	7203B	Ball Bearings	36	7340B	Ball Bearings	38	18590	Tapered	134
6834	Ball Bearings	20	7203C	Precision	194	7405B	Ball Bearings	40	18620	Tapered	136
6836	Ball Bearings	20	07204	Tapered	132	7406B	Ball Bearings	40	18690	Tapered	136
6838	Ball Bearings	20	07204	Tapered	132	7407B	Ball Bearings	40	22206CE4	Spherical	70
6840	Ball Bearings	20	7204A5	Precision	196	7408B	Ball Bearings	40	22206HE4	Spherical	70
6900	Ball Bearings	22	7204B	Ball Bearings	36	7409B	Ball Bearings	40	22207CE4	Spherical	70
6901	Ball Bearings	22	7204C	Precision	194	7410B	Ball Bearings	40	22207HE4	Spherical	70

Introduction
Ball Bearings
Cylindrical Roller Bearings
Spherical Roller Bearings
Tapered Roller Bearings
Thrust Bearings
Split Pillow Blocks
Super Precision Bearings
Linear Motion
Rolling Mill Bearings
Engineering Section

NSK NSK NSK NSK NSK NSK NSK NSK

	Bearing No. (prefix, no., Suffix)			Section	Page	Bearing No. (prefix, no., Suffix)			Section	Page	Bearing No. (prefix, no., Suffix)			Section	Page
Introduction	22208CDE4	Spherical	70		22322HE4	Spherical	76		23234CE4	Spherical	86	24176CXE4	Spherical	94	
	22208HE4	Spherical	70		22324GAME4	Spherical	76		23236CAME4	Spherical	86	24180CAME4	Spherical	94	
	22209CDE4	Spherical	70		22324GAME4C(4)U15-VS	Spherical	96		23236CE4	Spherical	86	24184CAME4	Spherical	94	
	22209HE4	Spherical	70		22324EA4	Spherical	76		23238CAME4	Spherical	86	24188CAME4	Spherical	94	
	22210CAME4	Spherical	70		22326CAME4	Spherical	76		23238CE4	Spherical	86	24192CAME4	Spherical	94	
	22210EA4	Spherical	70		22326CAME4C(4)U15-VS	Spherical	96		23240CAME4	Spherical	86	24196CAME4	Spherical	94	
	22210HE4	Spherical	70		22328CAME4	Spherical	76		23240CE4	Spherical	86	25520	Tapered	134	
	22211CAME4	Spherical	70		22328CAME4C(4)U15-VS	Spherical	96		23244CAME4	Spherical	86	25520	Tapered	136	
	22211EA4	Spherical	70		22328CE4	Spherical	76		23244CE4	Spherical	86	25523	Tapered	134	
	22211HE4	Spherical	70		22330CAME4	Spherical	76		23248CAME4	Spherical	86	25523	Tapered	136	
	22212CAME4	Spherical	70		22330CAME4C(4)U15-VS	Spherical	96		23252CAME4	Spherical	86	25577	Tapered	134	
	22212EA4	Spherical	70		22332CAME4	Spherical	76		23256	Tapered	132	25580	Tapered	134	
22212HE4	Spherical	70		22332CAME4C(4)U15-VS	Spherical	96		23256CAME4	Spherical	86	25590	Tapered	136		
22213CAME4	Spherical	70		22334CAME4	Spherical	76		23260CAME4	Spherical	88	25590	Tapered	136		
22213EA4	Spherical	70		22334CAME4C(4)U15-VS	Spherical	96		23264CAME4	Spherical	88	25821	Tapered	134		
22213HE4	Spherical	70		22336CAME4	Spherical	76		23268CAME4	Spherical	88	25877	Tapered	134		
22214CAME4	Spherical	70		22338CAME4	Spherical	76		23272CAME4	Spherical	88	26822	Tapered	134		
22214EA4	Spherical	70		22338CAME4C(4)U15-VS	Spherical	96		23276CAME4	Spherical	88	26882	Tapered	134		
22214HE4	Spherical	70		22340CAME4	Spherical	76		23280CAME4	Spherical	88	29240	Thrust	149		
22215CAME4	Spherical	70		22340CAME4C(4)U15-VS	Spherical	96		23284CAME4	Spherical	88	29240	Thrust	150		
22215EA4	Spherical	70		22344CAME4	Spherical	76		23288CAME4	Spherical	88	29244	Thrust	150		
22215HE4	Spherical	70		22348CAME4	Spherical	76		23292CAME4	Spherical	88	29248	Thrust	150		
22216CAME4	Spherical	70		22352CAME4	Spherical	76		23296CAME4	Spherical	88	29252	Thrust	150		
22216EA4	Spherical	70		22356CAME4	Spherical	76		23326CAME4C(4)U15-VS	Spherical	96	29256	Thrust	150		
22216HE4	Spherical	70		22360CAME4	Spherical	76		23332CAME4C(4)U15-VS	Spherical	96	29260	Thrust	150		
22217CAME4	Spherical	70		22364CAME4	Spherical	76		23326CAME4	Spherical	90	29264	Thrust	150		
22217EA4	Spherical	70		23020CDE4	Spherical	78		23332CAME4	Spherical	90	29272	Thrust	150		
22217HE4	Spherical	70		23022CDE4	Spherical	78		23384CAME4	Spherical	90	29276	Thrust	152		
22218CAME4	Spherical	70		23024CAME4	Spherical	78		23396CAME4	Spherical	90	29280	Thrust	152		
22218EA4	Spherical	70		23024CDE4	Spherical	78		23398CAME4	Spherical	90	29284	Thrust	152		
22218HE4	Spherical	70		23026CAME4	Spherical	78		23944CAME4	Spherical	90	29288	Thrust	152		
22219CAME4	Spherical	72		23026CDE4	Spherical	78		23948CAME4	Spherical	90	29292	Thrust	152		
22219EA4	Spherical	72		23028CAME4	Spherical	78		23952CAME4	Spherical	90	29296	Thrust	152		
22219HE4	Spherical	72		23028CDE4	Spherical	78		23956CAME4	Spherical	90	29317E	Thrust	148		
22220CAME4	Spherical	72		23030CAME4	Spherical	78		23960CAME4	Spherical	90	29318E	Thrust	148		
22220EA4	Spherical	72		23030CDE4	Spherical	78		23964CAME4	Spherical	90	29320E	Thrust	148		
22220HE4	Spherical	72		23032CAME4	Spherical	78		23968CAME4	Spherical	90	29322E	Thrust	148		
22222CAME4	Spherical	72		23032CDE4	Spherical	78		23972CAME4	Spherical	90	29324E	Thrust	148		
22222EA4	Spherical	72		23034CAME4	Spherical	78		23976CAME4	Spherical	90	29326E	Thrust	148		
22222HE4	Spherical	72		23034CDE4	Spherical	78		23980CAME4	Spherical	90	29328E	Thrust	148		
22224CAME4	Spherical	72		23036CAME4	Spherical	78		23984CAME4	Spherical	90	29330E	Thrust	148		
22224EA4	Spherical	72		23036CDE4	Spherical	78		23988CAME4	Spherical	90	29332E	Thrust	148		
22224HE4	Spherical	72		23040CAME4	Spherical	78		23992CAME4	Spherical	90	29334E	Thrust	148		
22226CAME4	Spherical	72		23044CAME4	Spherical	78		23996CAME4	Spherical	90	29336E	Thrust	148		
22226EA4	Spherical	72		23048CAME4	Spherical	78		24020CE4	Spherical	92	29338E	Thrust	148		
22226HE4	Spherical	72		23052CAME4	Spherical	78		24022CE4	Spherical	92	29340E	Thrust	149		
22228CAME4	Spherical	72		23056CAME4	Spherical	78		24024CAME4	Spherical	92	29340H	Thrust	150		
22228CDE4	Spherical	72		23060CAME4	Spherical	78		24024CE4	Spherical	92	29344	Thrust	150		
22230CAME4	Spherical	72		23064CAME4	Spherical	78		24026CAME4	Spherical	92	29348	Thrust	150		
22230CDE4	Spherical	72		23068CAME4	Spherical	78		24028CAME4	Spherical	92	29352	Thrust	150		
22232CAME4	Spherical	72		23072CAME4	Spherical	78		24028CE4	Spherical	92	29356	Thrust	150		
22232CDE4	Spherical	72		23076CAME4	Spherical	78		24030CAME4	Spherical	92	29360	Thrust	150		
22234CAME4	Spherical	72		23080CAME4	Spherical	78		24032CAME4	Spherical	92	29368	Thrust	150		
22234CDE4	Spherical	72		23084CAME4	Spherical	78		24032CE4	Spherical	92	29372	Thrust	152		
22236CAME4	Spherical	72		23088CAME4	Spherical	78		24034CAME4	Spherical	92	29380	Thrust	152		
22238CAME4	Spherical	72		23092CAME4	Spherical	78		24034CE4	Spherical	92	29384	Thrust	152		
22240CAME4	Spherical	72		23096CAME4	Spherical	78		24036CAME4	Spherical	92	29388	Thrust	152		
22244CAME4	Spherical	72		23100	Tapered	132		24036CE4	Spherical	92	29392	Thrust	152		
22248CAME4	Spherical	72		23120CAME4	Spherical	82		24038CAME4	Spherical	92	29396	Thrust	148		
22252CAME4	Spherical	72		23122CAME4	Spherical	82		24038CE4	Spherical	92	29412E	Thrust	152		
22256CAME4	Spherical	72		23122CDE4	Spherical	82		24040CAME4	Spherical	92	29413E	Thrust	148		
22260CAME4	Spherical	72		23124CAME4	Spherical	82		24040CE4	Spherical	92	29414E	Thrust	148		
22264CAME4	Spherical	72		23126CAME4	Spherical	82		24044CAME4	Spherical	92	29415E	Thrust	148		
22308CAME4	Spherical	74		23126CDE4	Spherical	82		24044CE4	Spherical	92	29417E	Thrust	148		
22308CAME4C(4)U15-VS	Spherical	96		23128CAME4	Spherical	82		24048CAME4	Spherical	92	29418E	Thrust	148		
22308CDE4	Spherical	74		23128CDE4	Spherical	82		24052CAME4	Spherical	92	29420E	Thrust	148		
22308HE4	Spherical	74		23130CAME4	Spherical	82		24056CAME4	Spherical	92	29422E	Thrust	148		
22309CAME4	Spherical	74		23130CE4	Spherical	82		24060CAME4	Spherical	92	29424E	Thrust	148		
22309CAME4C(4)U15-VS	Spherical	96		23132CAME4	Spherical	82		24064CAME4	Spherical	92	29426E	Thrust	148		
22309CDE4	Spherical	74		23132CE4	Spherical	82		24068CAME4	Spherical	92	29428E	Thrust	148		
22309HE4	Spherical	74		23134CAME4	Spherical	82		24072CAME4	Spherical	92	29430E	Thrust	148		
22310CAME4	Spherical	74		23134CE4	Spherical	82		24076CAME4	Spherical	92	29432E	Thrust	148		
22310CAME4C(4)U15-VS	Spherical	96		23136CAME4	Spherical	82		24080CAME4	Spherical	92	29434	Thrust	148		
22310EA4	Spherical	74		23136CE4	Spherical	82		24084CAME4	Spherical	92	29436	Thrust	148		
22310HE4	Spherical	74		23138CAME4	Spherical	82		24088CAME4	Spherical	92	29438	Thrust	148		
22311CAME4	Spherical	74		23140CAME4	Spherical	82		24092CAME4	Spherical	92	29440	Thrust	149		
22311CAME4C(4)U15-VS	Spherical	96		23140CE4	Spherical	82		24096CAME4	Spherical	92	29444	Thrust	150		
22311EA4	Spherical	74		23144CAME4	Spherical	82		24120CAME4	Spherical	94	29448	Thrust	150		
22311HE4	Spherical	74		23144CE4	Spherical	82		24122CAME4	Spherical	94	29452	Thrust	150		
22312CAME4	Spherical	74		23148CAME4	Spherical	82		24122CE4	Spherical	94	29456	Thrust	150		
22312CAME4C(4)U15-VS	Spherical	96		23148CE4	Spherical	82		24124CAME4	Spherical	94	29460	Thrust	150		
22312EA4	Spherical	74		23152CAME4	Spherical	82		24124CE4	Spherical	94	29464	Thrust	150		
22312HE4	Spherical	74		23156CAME4	Spherical	82		24126CAME4	Spherical	94	29468	Thrust	150		
22313CAME4	Spherical	74		23160CAME4	Spherical	82		24126CE4	Spherical	94	29472	Thrust	150		
22313CAME4C(4)U15-VS	Spherical	96		23164CAME4	Spherical	82		24128CAME4	Spherical	94	29476	Thrust	152		
22313EA4	Spherical	74		23164CE4	Spherical	82		24128CE4	Spherical	94	29480	Thrust	152		
22313HE4	Spherical	74		23168CAME4	Spherical	82		24130CAME4	Spherical	94	29484	Thrust	152		
22314CAME4	Spherical	74		23172CAME4	Spherical	82		24130CE4	Spherical	94	29488	Thrust	152		
22314CAME4C(4)U15-VS	Spherical	96		23176CAME4	Spherical	82		24132CAME4	Spherical	94	29492	Thrust	152		
22314EA4	Spherical	74		23180CAME4	Spherical	84		24132CE4	Spherical	94	29496	Thrust	152		
22314HE4	Spherical	74		23184CAME4	Spherical	84		24134CAME4	Spherical	94	30216C	Tapered	124		
22315CAME4	Spherical	74		23											

Bearing No. (prefix, no., Suffix)	Section	Page	Bearing No. (prefix, no., Suffix)	Section	Page	Bearing No. (prefix, no., Suffix)	Section	Page	Bearing No. (prefix, no., Suffix)	Section	Page
30344	Tapered	106	51420X	Thrust	146	HR30207C	Tapered	124	HR322/32	Tapered	112
30348	Tapered	106	51422X	Thrust	146	HR30207J	Tapered	104	HR32203J	Tapered	104
30352	Tapered	106	51424X	Thrust	146	HR30208C	Tapered	124	HR32204J	Tapered	112
32248	Tapered	112	51426X	Thrust	146	HR30208J	Tapered	104	HR32205J	Tapered	112
32252	Tapered	112	51428X	Thrust	146	HR30209C	Tapered	124	HR32206J	Tapered	112
32256	Tapered	112	51430X	Thrust	146	HR30209J	Tapered	104	HR32207J	Tapered	112
32260	Tapered	112	51432X	Thrust	146	HR30210C	Tapered	124	HR32208J	Tapered	112
32264	Tapered	112	63204DDU	Ball Bearings	24	HR30210J	Tapered	104	HR32209J	Tapered	112
32303	Tapered	114	63205DDU	Ball Bearings	24	HR30211J	Tapered	104	HR32210J	Tapered	112
32312C	Tapered	130	63206DDU	Ball Bearings	24	HR30212J	Tapered	104	HR32211J	Tapered	112
32314C	Tapered	130	63207DDU	Ball Bearings	24	HR30213J	Tapered	104	HR32212J	Tapered	112
32315C	Tapered	130	63208DDU	Ball Bearings	24	HR30214J	Tapered	104	HR32213J	Tapered	112
32326	Tapered	114	63209DDU	Ball Bearings	24	HR30215J	Tapered	104	HR32214J	Tapered	112
32328	Tapered	114	63310DDU	Ball Bearings	25	HR30216J	Tapered	104	HR32215J	Tapered	112
32330	Tapered	114	63311DDU	Ball Bearings	25	HR30217J	Tapered	104	HR32216J	Tapered	112
32332	Tapered	114	63312DDU	Ball Bearings	25	HR30218J	Tapered	104	HR32217J	Tapered	112
32334	Tapered	114	885117	Ball Bearings	45	HR30219J	Tapered	104	HR32218J	Tapered	112
32336	Tapered	114	885118	Ball Bearings	45	HR30220J	Tapered	104	HR32219J	Tapered	112
32340	Tapered	114	885586	Ball Bearings	45	HR30221J	Tapered	104	HR32220J	Tapered	112
32344	Tapered	114	885801	Ball Bearings	45	HR30222J	Tapered	104	HR32221J	Tapered	112
32348	Tapered	114	885801SE	Ball Bearings	45	HR30224J	Tapered	104	HR32222J	Tapered	112
32364	Tapered	116	885807C	Ball Bearings	45	HR30226J	Tapered	104	HR32224J	Tapered	112
32976	Tapered	116	885820	Ball Bearings	45	HR30228J	Tapered	104	HR32226J	Tapered	112
32980	Tapered	116	A4050	Tapered	132	HR303/22	Tapered	106	HR32228J	Tapered	112
33287	Tapered	136	A4059	Tapered	132	HR303/22C	Tapered	126	HR32230J	Tapered	112
33462	Tapered	136	A4138	Tapered	132	HR303/28	Tapered	106	HR32232J	Tapered	112
39520	Tapered	136	A4138	Tapered	132	HR303/28C	Tapered	126	HR32234J	Tapered	112
39520	Tapered	136	A6062	Tapered	132	HR303/32	Tapered	106	HR32236J	Tapered	112
39585	Tapered	136	A6067	Tapered	132	HR303/32C	Tapered	126	HR32238J	Tapered	112
39590	Tapered	136	A6075	Tapered	132	HR30302J	Tapered	106	HR32240J	Tapered	112
47620	Tapered	136	A6157	Tapered	132	HR30303J	Tapered	106	HR32244J	Tapered	112
47686	Tapered	136	A6157	Tapered	132	HR30304C	Tapered	126	HR323/28C	Tapered	130
51100	Thrust	142	A6157	Tapered	132	HR30304J	Tapered	106	HR323/32C	Tapered	130
51101	Thrust	142	A7420B	Ball Bearings	40	HR30305C	Tapered	126	HR32304C	Tapered	130
51102	Thrust	142	A99202-08A	Ball Bearings	44	HR30305J	Tapered	106	HR32304J	Tapered	114
51103	Thrust	142	AN15	Split Block	181	HR30306C	Tapered	126	HR32305C	Tapered	130
51104	Thrust	142	AN16	Split Block	181	HR30306J	Tapered	106	HR32305J	Tapered	114
51105	Thrust	142	AN17	Split Block	181	HR30307C	Tapered	126	HR32306C	Tapered	130
51106	Thrust	142	AN18	Split Block	181	HR30307J	Tapered	106	HR32306J	Tapered	114
51107	Thrust	142	AN19	Split Block	181	HR30308C	Tapered	126	HR32307C	Tapered	130
51108	Thrust	142	AN20	Split Block	181	HR30308J	Tapered	106	HR32307J	Tapered	114
51109	Thrust	142	AN21	Split Block	181	HR30309C	Tapered	126	HR32308C	Tapered	130
51110	Thrust	144	AN22	Split Block	181	HR30309J	Tapered	106	HR32308J	Tapered	114
51111	Thrust	144	AN24	Split Block	181	HR30310C	Tapered	126	HR32309C	Tapered	130
51112	Thrust	144	AN26	Split Block	181	HR30310J	Tapered	106	HR32309J	Tapered	114
51113	Thrust	144	AN28	Split Block	181	HR30311J	Tapered	106	HR32310C	Tapered	130
51114	Thrust	144	AN30	Split Block	181	HR30312J	Tapered	106	HR32310J	Tapered	114
51115	Thrust	144	AN32	Split Block	181	HR30313J	Tapered	106	HR32311J	Tapered	114
51116	Thrust	144	AN34	Split Block	181	HR30314J	Tapered	106	HR32312J	Tapered	114
51117	Thrust	144	AN36	Split Block	181	HR30315J	Tapered	106	HR32313J	Tapered	114
51118	Thrust	146	AN38	Split Block	181	HR30316J	Tapered	106	HR32314J	Tapered	114
51120	Thrust	146	AN40	Split Block	181	HR30317J	Tapered	106	HR32315J	Tapered	114
51122	Thrust	146	BL205	Ball Bearings	42	HR30318J	Tapered	106	HR32316J	Tapered	114
51124	Thrust	146	BL206	Ball Bearings	42	HR30319J	Tapered	106	HR32317J	Tapered	114
51126	Thrust	146	BL207	Ball Bearings	42	HR30320J	Tapered	106	HR32318J	Tapered	114
51128X	Thrust	146	BL208	Ball Bearings	42	HR30321J	Tapered	106	HR32319J	Tapered	114
51130X	Thrust	146	BL209	Ball Bearings	42	HR30322J	Tapered	106	HR32320J	Tapered	114
51132X	Thrust	146	BL210	Ball Bearings	42	HR30324J	Tapered	106	HR32321J	Tapered	114
51200	Thrust	142	BL211	Ball Bearings	42	HR31305J	Tapered	108	HR32322J	Tapered	114
51201	Thrust	142	BL212	Ball Bearings	42	HR31306J	Tapered	108	HR32324J	Tapered	114
51202	Thrust	142	BL213	Ball Bearings	42	HR31307J	Tapered	108	HR32306J	Tapered	116
51203	Thrust	142	BL214	Ball Bearings	42	HR31308J	Tapered	108	HR32907J	Tapered	116
51204	Thrust	142	BL215	Ball Bearings	42	HR31309J	Tapered	108	HR32908J	Tapered	116
51205	Thrust	142	BL216	Ball Bearings	42	HR31310J	Tapered	108	HR32909J	Tapered	116
51206	Thrust	142	BL217	Ball Bearings	42	HR31311J	Tapered	108	HR32910J	Tapered	116
51207	Thrust	142	BL218	Ball Bearings	42	HR31312J	Tapered	108	HR32911J	Tapered	116
51208	Thrust	142	BL219	Ball Bearings	42	HR31313J	Tapered	108	HR32912J	Tapered	116
51209	Thrust	142	BL220	Ball Bearings	42	HR31314J	Tapered	108	HR32913J	Tapered	116
51210	Thrust	144	BL221	Ball Bearings	42	HR31315J	Tapered	108	HR32914J	Tapered	116
51211	Thrust	144	BL305	Ball Bearings	42	HR31316J	Tapered	108	HR32915J	Tapered	116
51212	Thrust	144	BL306	Ball Bearings	42	HR31317J	Tapered	108	HR32916J	Tapered	116
51213	Thrust	144	BL307	Ball Bearings	42	HR31318J	Tapered	108	HR32917J	Tapered	116
51214	Thrust	144	BL308	Ball Bearings	42	HR31319J	Tapered	108	HR32918J	Tapered	116
51215	Thrust	144	BL309	Ball Bearings	42	HR31320J	Tapered	108	HR32919J	Tapered	116
51216	Thrust	144	BL310	Ball Bearings	42	HR31321J	Tapered	108	HR32920J	Tapered	116
51217	Thrust	144	BL311	Ball Bearings	42	HR31322J	Tapered	108	HR32921J	Tapered	116
51218	Thrust	146	BL312	Ball Bearings	42	HR31324J	Tapered	108	HR32922J	Tapered	116
51220	Thrust	146	BL313	Ball Bearings	42	HR31326J	Tapered	108	HR32924J	Tapered	116
51222	Thrust	146	BL314	Ball Bearings	42	HR31328J	Tapered	108	HR32926J	Tapered	116
51224	Thrust	146	BL315	Ball Bearings	42	HR31330J	Tapered	108	HR32928J	Tapered	116
51226X	Thrust	146	BL316	Ball Bearings	42	HR320/22XJ	Tapered	110	HR32930J	Tapered	116
51228X	Thrust	146	BL317	Ball Bearings	42	HR320/28XJ	Tapered	110	HR32932J	Tapered	116
51230X	Thrust	146	BL318	Ball Bearings	42	HR320/32XJ	Tapered	110	HR32934J	Tapered	116
51232X	Thrust	146	BL319	Ball Bearings	42	HR32004XJ	Tapered	110	HR32936J	Tapered	116
51305	Thrust	142	FSAF216	Split Block	160	HR32005KJ	Tapered	110	HR32938J	Tapered	116
51306	Thrust	142	FSAF217	Split Block	160	HR32006KJ	Tapered	110	HR32940J	Tapered	116
51307	Thrust	142	FSAF218	Split Block	160	HR32007KJ	Tapered	110	HR32944J	Tapered	116
51308	Thrust	142	FSAF220	Split Block	160	HR32008KJ	Tapered	110	HR32948J	Tapered	116
51309	Thrust	142	FSAF311	Split Block	162	HR32009KJ	Tapered	110	HR32952J	Tapered	116
51310	Thrust	144	FSAF313	Split Block	162	HR32010XJ	Tapered	110	HR32956J	Tapered	116
51311	Thrust	144	FSAF315	Split Block	162	HR32011XJ	Tapered	110	HR32960J	Tapered	116
51312	Thrust	144	FSAF316	Split Block	162	HR32012XJ	Tapered	110	HR32968J	Tapered	116
51313	Thrust	144	FSAF317	Split Block	162	HR32013XJ	Tapered	110	HR32972J	Tapered	116
51314	Thrust	144	FSAF513	Split Block	164	HR32014XJ	Tapered	110	HR33005J	Tapered	118
51315	Thrust	144	FSAF515	Split Block	164	HR32015XJ	Tapered	110	HR33006J	Tapered	118
51316	Thrust	144	FSAF516	Split Block	164	HR32016XJ	Tapered	110	HR33007J	Tapered	118
51317	Thrust	144	FSAF517	Split Block	164	HR32017XJ	Tapered	110	HR33008J	Tapered	118
51318	Thrust	146	FSAF518	Split Block	164	HR32018XJ	Tapered	110	HR33009J	Tapered	118
51320	Thrust	146	FSAF520	Split Block	164	HR32019XJ	Tapered	110	HR33010J	Tapered	118
51322X	Thrust	146	FSAF611	Split Block	166	HR32020XJ	Tapered	110	HR33011J	Tapered	118
51324X	Thrust	146	FSAF613	Split Block	166	HR32021XJ	Tapered	110	HR33012J	Tapered	118
51326X	Thrust	146	FSAF615	Split Block	166	HR32022XJ	Tapered	110	HR33013J	Tapered	118
51328X	Thrust	146	FSAF616	Split Block	166	HR32024XJ	Tapered	110	HR33014J	Tapered	118
51330X	Thrust	146	FSAF617	Split Block	166	HR32026XJ	Tapered	110	HR33015J	Tapered	118
51332X	Thrust	146	HM212047	Tapered	136	HR32028XJ	Tapered	110	HR33016J	Tapered	118
51405	Thrust	142	HM89410	Tapered	134	HR32030XJ	Tapered	110	HR33017J	Tapered	118
51407	Thrust	142	HM89449	Tapered	134	HR32032XJ	Tapered	110	HR33018J	Tapered	118
51408	Thrust	142	HR302/22C	Tapered	124	HR32034XJ	Tapered	110	HR33019J	Tapered	118
51409	Thrust	142	HR302/28C	Tapered	124	HR32036XJ	Tapered	110			

Introduction
Bearings
Roller Bearings
Cylindrical Roller Bearings
Spherical Roller Bearings
Tapered Roller Bearings
Thrust Bearings
Spilt Pillow Blocks
Super Precision Bearings
Linear Motion
Rolling Mill Bearings
Engineering Section

Bearing No. (prefix, no., Suffix) Section Page				Bearing No. (prefix, no., Suffix) Section Page				Bearing No. (prefix, no., Suffix) Section Page				Bearing No. (prefix, no., Suffix) Section Page			
HR33116J	Tapered	120		LAH35EL/FLZ	Linear	238		N,NU,NJ211	Cylindrical	52		N,NU,NJ414	Cylindrical	56	
HR33117J	Tapered	120		LAH35EM/EMZ	Linear	240		N,NU,NJ212	Cylindrical	52		N,NU,NJ415	Cylindrical	56	
HR33118J	Tapered	120		LAH35GL/HLZ	Linear	238		N,NU,NJ213	Cylindrical	52		N,NU,NJ416	Cylindrical	56	
HR33120J	Tapered	120		LAH35GM/GMZ	Linear	240		N,NU,NJ214	Cylindrical	52		N,NU,NJ417	Cylindrical	56	
HR33122J	Tapered	120		LAH45	Linear	263		N,NU,NJ215	Cylindrical	52		N,NU,NJ418	Cylindrical	56	
HR33205J	Tapered	122		LAH45AN/ANZ	Linear	236		N,NU,NJ216	Cylindrical	52		N,NU,NJ419	Cylindrical	56	
HR33206J	Tapered	122		LAH45BN/BNZ	Linear	236		N,NU,NJ217	Cylindrical	52		N,NU,NJ420	Cylindrical	56	
HR33207J	Tapered	122		LAH45EL/FLZ	Linear	238		N,NU,NJ218	Cylindrical	52		N,NU,NJ421	Cylindrical	56	
HR33208J	Tapered	122		LAH45EM/EMZ	Linear	240		N,NU,NJ219	Cylindrical	52		N,NU,NJ422	Cylindrical	56	
HR33209J	Tapered	122		LAH45GL/HLZ	Linear	238		N,NU,NJ220	Cylindrical	52		N,NU,NJ424	Cylindrical	56	
HR33210J	Tapered	122		LAH45GM/GMZ	Linear	240		N,NU,NJ220S	Cylindrical	60		N,NU,NJ426	Cylindrical	56	
HR33211J	Tapered	122		LAH55	Linear	263		N,NU,NJ2206	Cylindrical	60		N,NU,NJ428	Cylindrical	56	
HR33212J	Tapered	122		LAH55AN/ANZ	Linear	236		N,NU,NJ2207	Cylindrical	60		N,NU,NJ430	Cylindrical	56	
HR33213J	Tapered	122		LAH55BN/BNZ	Linear	236		N,NU,NJ2208	Cylindrical	60		N,NU,1005	Cylindrical	58	
HR33214J	Tapered	122		LAH55EL/FLZ	Linear	238		N,NU,NJ2209	Cylindrical	60		N,NU,1006	Cylindrical	58	
HR33215J	Tapered	122		LAH55EM/EMZ	Linear	240		N,NU,NJ221	Cylindrical	52		N,NU,1007	Cylindrical	58	
HR33216J	Tapered	122		LAH55GL/HLZ	Linear	238		N,NU,NJ2210	Cylindrical	60		N,NU,1008	Cylindrical	58	
HR33217J	Tapered	122		LAH55GM/GMZ	Linear	240		N,NU,NJ2211	Cylindrical	60		N,NU,1009	Cylindrical	58	
HR33220J	Tapered	122		LAH65	Linear	266		N,NU,NJ2212	Cylindrical	60		N,NU,1010	Cylindrical	58	
JL69310	Tapered	134		LAH65AN/ANZ	Linear	236		N,NU,NJ2213	Cylindrical	60		N,NU,1011	Cylindrical	58	
JL69349	Tapered	134		LAH65BN/BNZ	Linear	236		N,NU,NJ2214	Cylindrical	60		N,NU,1012	Cylindrical	58	
LI E09'S	Linear	253		LAH65EL/FLZ	Linear	238		N,NU,NJ2215	Cylindrical	60		N,NU,1013	Cylindrical	58	
LI E12'S	Linear	253		LAH65EM/EMZ	Linear	240		N,NU,NJ2216	Cylindrical	60		N,NU,1014	Cylindrical	58	
LI E15'S	Linear	253		LAH65GL/HLZ	Linear	238		N,NU,NJ2217	Cylindrical	60		N,NU,1015	Cylindrical	58	
LIH15	Linear	242		LAH65GM/GMZ	Linear	240		N,NU,NJ2218	Cylindrical	60		N,NU,1016	Cylindrical	58	
LIH15-01	Linear	242		LAS15	Linear	263		N,NU,NJ2219	Cylindrical	60		N,NU,1017	Cylindrical	58	
LIH15-01Z	Linear	242		LAS15AL/ALZ	Linear	246		N,NU,NJ222	Cylindrical	52		N,NU,1018	Cylindrical	58	
LIH15-Z	Linear	242		LAS15CL/CLZ	Linear	246		N,NU,NJ2220	Cylindrical	60		N,NU,1019	Cylindrical	58	
LIH20	Linear	242		LAS15EL/ELZ	Linear	248		N,NU,NJ2222	Cylindrical	60		N,NU,1020	Cylindrical	58	
LIH20-01	Linear	242		LAS15FL/FLZ	Linear	248		N,NU,NJ2224	Cylindrical	60		N,NU,1021	Cylindrical	58	
LIH20-01Z	Linear	242		LAS15KL/KLZ	Linear	248		N,NU,NJ2226	Cylindrical	60		N,NU,1022	Cylindrical	58	
LIH20-Z	Linear	242		LAS20	Linear	263		N,NU,NJ2228	Cylindrical	60		N,NU,1024	Cylindrical	58	
LIH25	Linear	242		LAS20AL/ALZ	Linear	246		N,NU,NJ2230	Cylindrical	60		N,NU,1026	Cylindrical	58	
LIH25-01	Linear	242		LAS20CL/CLZ	Linear	246		N,NU,NJ2232	Cylindrical	60		N,NU,1028	Cylindrical	58	
LIH25-01Z	Linear	242		LAS20EL/ELZ	Linear	248		N,NU,NJ2234	Cylindrical	60		N,NU,1030	Cylindrical	58	
LIH25-Z	Linear	242		LAS20FL/FLZ	Linear	248		N,NU,NJ2236	Cylindrical	60		N,NU,1032	Cylindrical	58	
LIH30	Linear	242		LAS20KL/KLZ	Linear	248		N,NU,NJ2238	Cylindrical	60		N,NU,1034	Cylindrical	58	
LIH30-01	Linear	242		LAS25	Linear	263		N,NU,NJ224	Cylindrical	52		N,NU,1036	Cylindrical	58	
LIH30-01Z	Linear	242		LAS25AL/ALZ	Linear	246		N,NU,NJ2240	Cylindrical	60		N,NU,1038	Cylindrical	58	
LIH30-Z	Linear	242		LAS25CL/CLZ	Linear	246		N,NU,NJ2244	Cylindrical	60		N,NU,1040	Cylindrical	58	
LIH35	Linear	242		LAS25EL/ELZ	Linear	248		N,NU,NJ2248	Cylindrical	60		N,NU,1044	Cylindrical	58	
LIH35-01	Linear	242		LAS25FL/FLZ	Linear	248		N,NU,NJ2252	Cylindrical	60		N,NU,1048	Cylindrical	58	
LIH35-01Z	Linear	242		LAS25KL/KLZ	Linear	248		N,NU,NJ226	Cylindrical	52		N,NU,1052	Cylindrical	58	
LIH35-Z	Linear	242		LAS30	Linear	263		N,NU,NJ228	Cylindrical	52		N,NU,1056	Cylindrical	58	
LIH45	Linear	242		LAS30AL/ALZ	Linear	246		N,NU,NJ230	Cylindrical	52		N,NU,1060	Cylindrical	58	
LIH45-01	Linear	242		LAS30CL/CLZ	Linear	246		N,NU,NJ230S	Cylindrical	62		N00	Split Block	181	
LIH45-01Z	Linear	242		LAS30EL/ELZ	Linear	248		N,NU,NJ2306	Cylindrical	62		N01	Split Block	181	
LIH45-Z	Linear	242		LAS30FL/FLZ	Linear	248		N,NU,NJ2307	Cylindrical	62		N02	Split Block	181	
LIH55	Linear	242		LAS30KL/KLZ	Linear	248		N,NU,NJ2308	Cylindrical	62		N03	Split Block	181	
LIH55-01	Linear	242		LAS35	Linear	263		N,NU,NJ2309	Cylindrical	62		N04	Split Block	181	
LIH55-01Z	Linear	242		LAS35AL/ALZ	Linear	246		N,NU,NJ2310	Cylindrical	62		N05	Split Block	181	
LIH55-Z	Linear	242		LAS35CL/CLZ	Linear	246		N,NU,NJ2311	Cylindrical	62		N06	Split Block	181	
LIH65	Linear	242		LAS35EL/ELZ	Linear	248		N,NU,NJ2312	Cylindrical	62		N07	Split Block	181	
LIH65-01	Linear	242		LAS35FL/FLZ	Linear	248		N,NU,NJ2313	Cylindrical	62		N08	Split Block	181	
LIH65-01Z	Linear	242		LAS35KL/KLZ	Linear	248		N,NU,NJ2314	Cylindrical	62		N09	Split Block	181	
LIH65-Z	Linear	242		LAU09	Linear	263		N,NU,NJ2315	Cylindrical	62		N10	Split Block	181	
LI S15	Linear	250		LAU09ARS	Linear	252		N,NU,NJ2316	Cylindrical	62		N1006	Precision	218	
LI S15T	Linear	250		LAU09TRS	Linear	252		N,NU,NJ2317	Cylindrical	62		N1007	Precision	218	
LI S20	Linear	250		LAU12	Linear	263		N,NU,NJ2318	Cylindrical	62		N1008	Precision	218	
LI S25	Linear	250		LAU12ARS	Linear	252		N,NU,NJ2319	Cylindrical	52		N1009	Precision	218	
LI S30	Linear	250		LAU12TRS	Linear	252		N,NU,NJ2320	Cylindrical	62		N1010	Precision	218	
LI S35	Linear	250		LAU15	Linear	263		N,NU,NJ2322	Cylindrical	62		N1011	Precision	218	
LI U09'S	Linear	252		LAU15ALS	Linear	252		N,NU,NJ2324	Cylindrical	62		N1012	Precision	218	
LI U09'TS	Linear	252		LAW17	Linear	263		N,NU,NJ2326	Cylindrical	62		N1013	Precision	218	
LIU12'S	Linear	252		LAW17EL/ELZ	Linear	254		N,NU,NJ2328	Cylindrical	62		N1014	Precision	218	
LIU12'TS	Linear	252		LAW21	Linear	263		N,NU,NJ2330	Cylindrical	62		N1015	Precision	218	
LIU15'S	Linear	252		LAW21EL/ELZ	Linear	254		N,NU,NJ2332	Cylindrical	62		N1016	Precision	218	
LIW17	Linear	254		LAW27	Linear	263		N,NU,NJ2334	Cylindrical	62		N1017	Precision	218	
LIW21	Linear	254		LAW27EL/ELZ	Linear	254		N,NU,NJ2336	Cylindrical	62		N1018	Precision	218	
LIW27	Linear	254		LAW35	Linear	263		N,NU,NJ2338	Cylindrical	62		N1019	Precision	218	
LIW35	Linear	254		LAW35EL/ELZ	Linear	254		N,NU,NJ2340	Cylindrical	52		N1020	Precision	218	
LIW50	Linear	254		LAW50	Linear	263		N,NU,NJ2342	Cylindrical	52		N1021	Precision	218	
L44610	Tapered	132		LAW50EL/ELZ	Linear	254		N,NU,NJ2344	Cylindrical	52		N1022	Precision	218	
L44610	Tapered	132		LM102910	Tapered	134		N,NU,NJ2346	Cylindrical	52		N1024	Precision	218	
L44643	Tapered	132		LM102949	Tapered	134		N,NU,NJ2348	Cylindrical	52		N1026	Precision	218	
L44649	Tapered	132		LM11710	Tapered	132		N,NU,NJ2349	Cylindrical	52		N1028	Precision	218	
L45410	Tapered	132		LM11749	Tapered	132		N,NU,NJ2350	Cylindrical	52		N11	Split Block	181	
L45449	Tapered	132		LM11910	Tapered	132		N,NU,NJ2352	Cylindrical	52		N12	Split Block	181	
L68110	Tapered	134		LM11949	Tapered	132		N,NU,NJ2354	Cylindrical	52		N13	Split Block	181	
L68111	Tapered	134		LM12710	Tapered	132		N,NU,NJ2356	Cylindrical	52		N14	Split Block	181	
L68149	Tapered	134		LM12711	Tapered	132		N,NU,NJ2358	Cylindrical	54		N44	Split Block	181	
L68149	Tapered	134		LM12749	Tapered	132		N,NU,NJ2360	Cylindrical	54		NK3005	Precision	220	
LAE09	Linear	263		LM12749	Tapered	132		N,NU,NJ2362	Cylindrical	54		NK3006	Precision	220	
LAE09ARS	Linear	253		LM29710	Tapered	134		N,NU,NJ2364	Cylindrical	54		NK3007	Precision	220	
LAE09TRS	Linear	253		LM29749	Tapered	134		N,NU,NJ2366	Cylindrical	54		NK3008	Precision	220	
LAE12	Linear	263		LM48510	Tapered	134		N,NU,NJ2368	Cylindrical	54		NK3009	Precision	220	
LAE12ARS	Linear	253		LM48548	Tapered	134		N,NU,NJ2370	Cylindrical	54		NK3010	Precision	220	
LAE15	Linear	263		LM501310	Tapered	134		N,NU,NJ2372	Cylindrical	54		NK3011	Precision	220	
LAE15ARS	Linear	253		LM501314	Tapered	134		N,NU,NJ2374	Cylindrical	54		NK3012	Precision	220	
LAH15	Linear	263		LM501349	Tapered	134		N,NU,NJ2376	Cylindrical	54		NK3013	Precision	220	
LAH15AN/ANZ	Linear	236		LM501349	Tapered	134		N,NU,NJ2378	Cylindrical	54		NK3014	Precision	220	
LAH15EL/FLZ	Linear	238		LM603011	Tapered	134		N,NU,NJ2380	Cylindrical	54		NK3015	Precision	220	
LAH15EM/EMZ	Linear	240		LM603012	Tapered	136		N,NU,NJ2382	Cylindrical	54		NK3016	Precision	220	
LAH15GL/HLZ	Linear	238		LM603049	Tapered	134		N,NU,NJ2384	Cylindrical	54		NK3017	Precision	220	
LAH15GM/GMZ	Linear	240		LM603049	Tapered	136		N,NU,NJ2386	Cylindrical	54		NK3018	Precision	220	
LAH20	Linear	263		LM67010	Tapered	134		N,NU,NJ2388	Cylindrical	54		NK3019	Precision	220	
LAH20AN/ANZ	Linear	236		LM67048	Tapered	134		N,NU,NJ2390	Cylindrical	54		NK3020	Precision	220	
LAH20BN/BNZ	Linear	236		LS15	Linear	244		N,NU,NJ2392	Cylindrical	54		NK3021	Precision	220	
LAH20EL/FLZ	Linear	238		LS20	Linear	244		N,NU,NJ2394	Cylindrical	54		NK3022	Precision	220	
LAH20EM/EMZ	Linear	240		LS25	Linear	244		N,NU,NJ2396	Cylindrical	54		NK3024	Precision	220	
LAH20GL/HLZ	Linear	238		LS30	Linear	244		N,NU,NJ2398	Cylindrical	54		NK3026	Precision	220	
LAH20GM/GMZ	Linear	240		LS35	Linear	244		N,NU,NJ2400	Cylindrical	54		NK3028	Precision	220	
LAH25	Linear	263		M12610	Taper										

NSK NSK NSK NSK NSK NSK NSK NSK NSK

Bearing No.			Bearing No.			Bearing No.			Bearing No.		
(prefix, no., Suffix)	Section	Page	(prefix, no., Suffix)	Section	Page	(prefix, no., Suffix)	Section	Page	(prefix, no., Suffix)	Section	Page
NN3932	Precision	222	SAF610	Split Block	166	SNW08X1-3/8	Split Block	178	W06	Split Block	181
NN3934	Precision	222	SAF611	Split Block	166	SNW08X1-5/16	Split Block	178	W07	Split Block	181
NN3936	Precision	222	SAF613	Split Block	166	SNW09X1-1/2	Split Block	178	W08	Split Block	181
NN3938	Precision	222	SAF615	Split Block	166	SNW09X1-3/8	Split Block	178	W09	Split Block	181
NN3940	Precision	222	SAF616	Split Block	166	SNW09X1-7/16	Split Block	178	W10	Split Block	181
NN3944	Precision	222	SAF617	Split Block	166	SNW10X1-1/2	Split Block	179	W11	Split Block	181
NN3948	Precision	222	SAF618	Split Block	166	SNW10X1-7/16	Split Block	179	W12	Split Block	181
NN3952	Precision	222	SAF620	Split Block	166	SNW10X1-11/16	Split Block	178	W13	Split Block	181
NN3956	Precision	222	SAF622	Split Block	166	SNW10X1-3/4	Split Block	178	W14	Split Block	181
NW32X5-7/16	Split Block	178	SAF624	Split Block	166	SNW10X1-5/8	Split Block	178	W15	Split Block	181
R10	Ball Bearings	12	SAF626	Split Block	166	SNW110X1-11/16	Split Block	179	W16	Split Block	181
R10ZZW	Ball Bearings	12	SAF628	Split Block	166	SNW110X1-3/4	Split Block	179	W17	Split Block	181
R12	Ball Bearings	12	SAF630	Split Block	166	SNW111X1-15/16	Split Block	179	W18	Split Block	181
R12ZZW	Ball Bearings	12	SAF632	Split Block	166	SNW111X1-7/8	Split Block	179	W19	Split Block	181
R14	Ball Bearings	12	SAF634	Split Block	166	SNW111X2	Split Block	179	W20	Split Block	181
R14ZZ	Ball Bearings	12	SAF636	Split Block	166	SNW113X2-1/4	Split Block	179	W21	Split Block	181
R16	Ball Bearings	12	SAF638	Split Block	166	SNW113X2-3/16	Split Block	179	W22	Split Block	181
R16ZZ	Ball Bearings	12	SAF640	Split Block	166	SNW115X2-1/2	Split Block	179	W24	Split Block	181
R18	Ball Bearings	12	SDF060K/10-15/16	Split Block	168	SNW115X2-3/8	Split Block	179	W26	Split Block	181
R18ZZ	Ball Bearings	12	SDF060K/11	Split Block	168	SNW115X2-7/16	Split Block	179	W28	Split Block	181
R20	Ball Bearings	12	SDF064K/11-1/2	Split Block	168	SNW116X2-11/16	Split Block	179	W30	Split Block	181
R20ZZ	Ball Bearings	12	SDF064K/11-15/16	Split Block	168	SNW116X2-3/4	Split Block	179	W32	Split Block	181
R22	Ball Bearings	12	SDF064K/11-7/16	Split Block	168	SNW117X2-15/16	Split Block	179	W34	Split Block	181
R22ZZ	Ball Bearings	12	SDF064K/12	Split Block	168	SNW117X3	Split Block	179	W36	Split Block	181
R24	Ball Bearings	12	SDF068K/12-1/2	Split Block	168	SNW118X3/316	Split Block	179	W38	Split Block	181
R24A	Ball Bearings	12	SDF068K/12-7/16	Split Block	168	SNW118X3-1/4	Split Block	179	W40	Split Block	181
R3	Ball Bearings	12	SDF072K/12-15/16	Split Block	168	SNW11X1-13/16	Split Block	178	W44	Split Block	181
R3ZZ	Ball Bearings	12	SDF072K/13	Split Block	168	SNW11X1-15/16	Split Block	178	WBK04R-11(Round)	Linear	273
R4AA	Ball Bearings	12	SDF072K/13-1/2	Split Block	168	SNW11X1-3/4	Split Block	178	WBK06-01A(Square)	Linear	273
R4AAZZ	Ball Bearings	12	SDF072K/13-7/16	Split Block	168	SNW11X1-7/8	Split Block	178	WBK06-11(Round)	Linear	273
R4B	Ball Bearings	12	SDF076K/13-15/16	Split Block	168	SNW11X2	Split Block	178	WBK06R-11(Round)	Linear	273
R6	Ball Bearings	12	SDF076K/14	Split Block	168	SNW120X3-1/2	Split Block	179	WBK08-01A(Square)	Linear	273
R6ZZW	Ball Bearings	12	SDF220	Split Block	170	SNW120X3-7/16	Split Block	179	WBK08-11(Round)	Linear	273
R8	Ball Bearings	12	SDF222	Split Block	170	SNW122X3-11/16	Split Block	179	WBK10-01A(Square)	Linear	273
R8ZZW	Ball Bearings	12	SDF224	Split Block	170	SNW122X3-15/16	Split Block	179	WBK10-11(Round)	Linear	273
RNCT	Linear	268	SDF226	Split Block	170	SNW122X4	Split Block	179	WBK12-01A(Square)	Linear	273
RNFBCL	Linear	268	SDF228	Split Block	170	SNW124X4-1/4	Split Block	179	WBK12-11(Round)	Linear	273
RNFCL	Linear	268	SDF230	Split Block	170	SNW124X4-3/16	Split Block	179	WBK15-01A(Square)	Linear	273
RNFTL	Linear	268	SDF232	Split Block	170	SNW126X4-1/2	Split Block	179	WBK15-11(Round)	Linear	273
RNSTL	Linear	268	SDF234	Split Block	170	SNW126X4-7/16	Split Block	179	WBK20-01(Square)	Linear	273
SAF024K/4-3/16	Split Block	158	SDF236	Split Block	170	SNW128X4-15/16	Split Block	179	WBK20-11(Round)	Linear	273
SAF026K/4-7/16	Split Block	158	SDF238	Split Block	170	SNW128X5	Split Block	179	WBK25-01(Square)	Linear	273
SAF028K/4-15/16	Split Block	158	SDF240	Split Block	170	SNW130X5-1/4	Split Block	179	WBK25-11(Round)	Linear	273
SAF030K/5-3/16	Split Block	158	SDF242	Split Block	170	SNW130X5-3/16	Split Block	179	X376RS	Ball Bearings	47
SAF032K/5-7/16	Split Block	158	SDF244	Split Block	170	SNW132X5-7/16	Split Block	179	X421RS	Ball Bearings	47
SAF034K/5-15/16	Split Block	158	SDF246	Split Block	170	SNW134X5-15/16	Split Block	179	X428	Ball Bearings	44
SAF036K/6-7/16	Split Block	158	SDF248	Split Block	170	SNW134X6	Split Block	179	X501	Ball Bearings	47
SAF038K/6-15/16	Split Block	158	SDF250	Split Block	170	SNW136X6-1/2	Split Block	179	X540XL	Ball Bearings	44
SAF040K/7-3/16	Split Block	158	SDF252	Split Block	172	SNW136X6-7/16	Split Block	179	X549RS	Ball Bearings	47
SAF044K/7-15/16	Split Block	158	SDF254	Split Block	172	SNW138X6-15/16	Split Block	179	X555	Ball Bearings	47
SAF048K/8-1/2	Split Block	158	SDF256	Split Block	172	SNW138X7	Split Block	179	Z9504B	Ball Bearings	44
SAF048K/8-15/16	Split Block	158	SDF258	Split Block	172	SNW13X2	Split Block	178			
SAF048K/8-7/16	Split Block	158	SDF260	Split Block	172	SNW13X2-1/4	Split Block	178			
SAF048K/9	Split Block	158	SDF262	Split Block	172	SNW13X2-3/16	Split Block	178			
SAF048K/9	Split Block	158	SDF264	Split Block	172	SNW13X2-5/16	Split Block	178			
SAF052K/9-1/2	Split Block	158	SDF266	Split Block	172	SNW140X7-3/16	Split Block	179			
SAF052K/9-7/16	Split Block	158	SDF268	Split Block	172	SNW144X7-15/16	Split Block	179			
SAF056K/10	Split Block	158	SDF270	Split Block	172	SNW144X8	Split Block	179			
SAF056K/10-1/2	Split Block	158	SDF272	Split Block	174	SNW15X2-1/2	Split Block	178			
SAF056K/10-7/16	Split Block	158	SDF274	Split Block	174	SNW15X2-3/8	Split Block	178			
SAF056K/9-15/16	Split Block	160	SDF276	Split Block	174	SNW15X2-5/8	Split Block	178			
SAF216	Split Block	160	SDF278	Split Block	174	SNW15X2-7/16	Split Block	178			
SAF217	Split Block	160	SDF280	Split Block	174	SNW16X2-11/16	Split Block	178			
SAF218	Split Block	160	SDF282	Split Block	174	SNW16X2-3/4	Split Block	178			
SAF220	Split Block	160	SDF284	Split Block	174	SNW17X2-15/16	Split Block	178			
SAF222	Split Block	160	SDF286	Split Block	174	SNW17X3	Split Block	178			
SAF224	Split Block	160	SDF288	Split Block	174	SNW18X3	Split Block	178			
SAF226	Split Block	160	SDF290	Split Block	174	SNW18X3-1/4	Split Block	178			
SAF228	Split Block	160	SDF292	Split Block	174	SNW20X3-1/2	Split Block	178			
SAF230	Split Block	160	SDF294	Split Block	174	SNW20X3-7/16	Split Block	178			
SAF232	Split Block	160	SDF296	Split Block	176	SNW22X3-11/16	Split Block	178			
SAF234	Split Block	160	SDF298	Split Block	176	SNW22X3-15/16	Split Block	178			
SAF236	Split Block	160	SDF300	Split Block	176	SNW22X4	Split Block	178			
SAF238	Split Block	160	SDF302	Split Block	176	SNW24X4-1/4	Split Block	178			
SAF240	Split Block	160	SDF304	Split Block	176	SNW24X4-3/16	Split Block	178			
SAF244	Split Block	160	SDF306	Split Block	176	SNW26X4-1/2	Split Block	178			
SAF308	Split Block	162	SDF308	Split Block	176	SNW26X4-7/16	Split Block	178			
SAF309	Split Block	162	SDF310	Split Block	176	SNW28X4-15/16	Split Block	178			
SAF310	Split Block	162	SDF312	Split Block	176	SNW28X4-7/8	Split Block	178			
SAF311	Split Block	162	SDF314	Split Block	176	SNW28X5	Split Block	178			
SAF313	Split Block	162	SDF316	Split Block	176	SNW3024X4-3/16	Split Block	180			
SAF314	Split Block	162	SDF318	Split Block	176	SNW3026X4-1/2	Split Block	180			
SAF315	Split Block	162	SDF320	Split Block	176	SNW3026X4-7/16	Split Block	180			
SAF316	Split Block	162	SDF322	Split Block	176	SNW3028X4-15/16	Split Block	180			
SAF317	Split Block	162	SDF324	Split Block	180	SNW3028X5	Split Block	180			
SAF318	Split Block	162	SDF326	Split Block	180	SNW3030X5-1/4	Split Block	180			
SAF320	Split Block	162	SDF328	Split Block	180	SNW3030X5-3/16	Split Block	180			
SAF322	Split Block	162	SDF330	Split Block	180	SNW3032X5-7/16	Split Block	180			
SAF324	Split Block	162	SDF332	Split Block	180	SNW3034X5-15/16	Split Block	180			
SAF326	Split Block	162	SDF334	Split Block	180	SNW3034X6	Split Block	180			
SAF328	Split Block	162	SDF336	Split Block	180	SNW3036X6-1/2	Split Block	180			
SAF330	Split Block	162	SDF338	Split Block	180	SNW3036X6-7/16	Split Block	180			
SAF332	Split Block	162	SDF340	Split Block	180	SNW3038X6-15/16	Split Block	180			
SAF334	Split Block	162	SDF342	Split Block	180	SNW3038X7	Split Block	180			
SAF336	Split Block	162	SDF344	Split Block	180	SNW3040X7-3/16	Split Block	180			
SAF338	Split Block	162	SDF346	Split Block	180	SNW3044X7-15/16	Split Block	180			
SAF340	Split Block	162	SDF348	Split Block	180	SNW3044X8	Split Block	180			
SAF507	Split Block	164	SDF350	Split Block	180	SNW3048X8	Split Block	180			
SAF509	Split Block	164	SDF352	Split Block	180	SNW30X5-1/4	Split Block	178			
SAF510	Split Block	164	SDF354	Split Block	180	SNW30X5-3/16	Split Block	178			
SAF511	Split Block	164	SDF356	Split Block	180	SNW32X5-1/2	Split Block	178			
SAF513	Split Block	164	SDF358	Split Block	180	SNW32X5-3/4	Split Block	178			
SAF515	Split Block	164	SDF360	Split Block	180	SNW34X5-15/16	Split Block	178			
SAF516	Split Block	164	SDF362	Split Block	180	SNW34X6	Split Block	178			
SAF517	Split Block	164	SDF364	Split Block	180	SNW36X6-1/2	Split Block	178			
SAF518	Split Block	164	SDF366	Split Block	180	SNW36X6-7/16	Split Block	178			
SAF520	Split Block	164	SDF368	Split Block	180	SNW38X6-15/16	Split Block	178			
SAF522	Split Block	164	SDF370	Split Block	180	SNW38X7	Split Block	178			
SAF524	Split Block	164	SDF372	Split Block	180	SNW40X7-3/16	Split Block	178			
SAF526	Split Block	164	SDF374	Split Block	180	SNW40X7-3/8	Split Block	178			
SAF528	Split Block	164	SDF376	Split Block	180	SNW44X7-1/2	Split Block	178			
SAF530	Split Block	164	SDF378	Split Block	180	SNW44X7-15/16	Split Block	178			
SAF532	Split Block	164	SDF380	Split Block	180	SNW44X7-7/8	Split Block	178			
SAF534	Split Block	164	SDF382	Split Block	180	SNW44X8	Split Block	178			
SAF536	Split Block	164	SDF384	Split Block	180	W00	Split Block	181			
SAF538	Split Block	164	SDF386	Split Block	180	W01	Split Block	181			
SAF540	Split Block	164	SDF388	Split Block	180	W02	Split Block	181			
SAF544	Split Block	164	SDF390								

Conversion Factors

	To Convert From	To	Multiply By	To Convert From	To	Multiply By
Length						
	Inch [in]	Millimeter [mm]	25.400 000	Millimeter [mm]	Inch [in]	0.039 370
	Foot [ft]	Meter [m]	0.304 800	Meter [m]	Foot [ft]	3.280 840
	Yard [yd]	Meter [m]	0.914 400	Meter [m]	Yard [yd]	1.093 613
	Mile (U.S. Statute) [mi]	Kilometer [km]	1.609 347	Kilometer [km]	Mile (U.S. Statute) [mi]	0.621 370
Area						
	Square Inch [in ²]	Square Millimeter [mm ²]	645.16	Square Millimeter [mm ²]	Square Inch [in ²]	0.001550
	Square Foot [ft ²]	Square Meter [m ²]	0.092 903	Square Meter [m ²]	Square Foot [ft ²]	10.763 915
	Square Yard [yd ²]	Square Meter [m ²]	0.836 127	Square Meter [m ²]	Square Yard [yd ²]	1.195 991
	Square Mile [mi ²] (U.S. Statute)	Square Kilometer [km ²]	2.589 998	Square Kilometer [km ²]	Square Mile [mi ²] (U.S. Statute)	0.386 101
	Acre	Square Meter [m ²]	4046.873	Square Meter [m ²]	Acre	0.000 247
	Acre	Hectare	0.404 687	Hectare	Acre	2.471 046
Volume						
	Cubic Inch [in ³]	Cubic Millimeter [mm ³]	16387.06	Cubic Millimeter [mm ³]	Cubic Inch [in ³]	0.000061
	Cubic Foot [ft ³]	Cubic Meter [m ³]	0.028 317	Cubic Meter [m ³]	Cubic Foot [ft ³]	35.314 662
	Cubic Yard [yd ³]	Cubic Meter [m ³]	0.764 555	Cubic Meter [m ³]	Cubic Yard [yd ³]	1.307 950
	Gallon (U.S. Liquid) [gal]	Litre [l]	3.785 412	Litre [l]	Gallon (U.S. Liquid) [gal]	0.264 172
	Quart (U.S. Liquid) [qt]	Litre [l]	0.946 353	Litre [l]	Quart (U.S. Liquid) [qt]	1.056 688
Mass						
	Ounce (Avoirdupois) [oz]	Gram [g]	28.349 520	Gram [g]	Ounce (Avoirdupois)	0.035 274 [oz]
	Pound (Avoirdupois) [lb]	Kilogram [kg]	0.453 592	Kilogram [kg]	Pound (Avoirdupois) [lb]	2.204 624
	Short Ton	Kilogram [kg]	907.185	Kilogram [kg]	Short Ton	0.00110
Force						
	Pound-Force [lbf]	Kilogram [kg]	0.453 592	Kilogram [kg]	Pound-Force [lbf]	2.204 624
	Pound-Force [lbf]	Newton [N]	4.448 222	Newton [N]	Pound-Force [lbf]	0.224 809
Bending Moment						
	Pound-Force-Inch [lbf-in]	Newton-Meter [N-m]	0.112 985	Newton-Meter [N-m]	Pound-Force-Inch [lbf-in]	8.850 732
	Pound-Force-Foot [lbf-ft]	Newton-Meter [N-m]	1.355 818	Newton-Meter [N-m]	Pound-Force-Foot [lbf-ft]	0.737 562
Pressure, Stress						
	Pound-Force per Square Inch [lbf/in ²]	Kilopascal [kPa]	6.894 757	Kilopascal [kPa]	Pound-Force per Square Inch [lbf/in ²]	0.145 038
	Foot of Water (39.2 F)	Kilopascal [kPa]	2.988 980	Kilopascal [kPa]	Foot of Water (39.2 F)	0.334 562
	Inch of Mercury (32 F)	Kilopascal [kPa]	3.386 380	Kilopascal [kPa]	Inch of Mercury (32 F)	0.295 301
Energy, Work, Heat						
	Foot-Pound-Force [ft-lbf]	Joule [J]	1.355 818	Joule [J]	Foot-Pound-Force [ft-lbf]	0.737 562
	British Thermal Unit [Btu]	Joule [J]	1055.056	Joule [J]	British Thermal Unit [Btu]	0.000948
	Calorie [cal]	Joule [J]	4.186 800	Joule [J]	Calorie [cal]	0.238 846
	Kilowatt Hour [kW-h]	Joule [J]	3600000	Joule [J]	Kilowatt Hour [kW-h]	2.78-7
Power						
	Foot-Pound-Force / Second [ft-lbs/s]	Watt [W]	1.355 818	Watt [W]	Foot-Pound-Force / Second [ft-lbs/s]	0.737 562
	British Thermal Unit / Hour [Btu/h]	Watt [W]	0.293 071	Watt [W]	British Thermal Unit / Hour [Btu/h]	3.412 142
	Horsepower (550 Ft. Lbf/s) [hp]	Kilowatt [kW]	0.745 700	Kilowatt [kW]	Horsepower (550 Ft. Lbf/s) [hp]	1.341 022
Angle						
	Degree	Radian [rad]	0.017 453	Radian [rad]	Degree	57.295 788
Temperature						
	Degree Fahrenheit [F]	Degree Celsius [C]	(F° -32)/1.8	Degree Celsius [C]	Degree Fahrenheit [F]	1.8xC°+32

X-ON Electronics

Largest Supplier of Electrical and Electronic Components

Click to view similar products for [Other Tools](#) category:

Click to view products by [NSK](#) manufacturer:

Other Similar products are found below :

[CR-05FL7--150R](#) [CR-05FL7--698K](#) [899-2-KT46](#) [899-5-KT46](#) [CR-0AFL4--332K](#) [CR-12FP4--260R](#) [CRCW04021100FRT7](#)
[CRCW04021961FRT7](#) [5800-0090](#) [CRCW04024021FRT7](#) [CRCW040254R9FRT7](#) [CRCW0603102JRT5](#) [59065-5](#) [00-8273-RDPP](#) [00-8729-](#)
[WHPP](#) [593033](#) [593058](#) [593072](#) [593564100](#) [593575](#) [593591](#) [593593](#) [011349-000](#) [LTLA506SBLAMNBL](#) [CRCW08052740FRT1](#) [LUC-](#)
[012S070DSM](#) [LUC-018S070DSP](#) [599-2021-3-NME](#) [599-JJ-2021-03](#) [00-5080-YWPP](#) [5E4750/01-20R0-T/R](#) [LW1A-L1-GL](#) [LW1A-P1-GD](#)
[LW1L-A1C10V-GL](#) [LW1L-M1C70-A](#) [0202-0173](#) [00-9089-RDPP](#) [00-9300-RDPP](#) [CRCW2010331JR02](#) [01-1003W-8/32-10](#) [601-GP-08-](#)
[KT39](#) [601-JJ-06](#) [601-SPB](#) [601YSY](#) [602-JJ-03](#) [602SPB](#) [602Z](#) [603-JJ-07-FP](#) [603-JJY-04](#) [604J](#)