

## NTE1869 & NTE1869SM Integrated Circuit 3 Terminal Variable Voltage Regulator

**Description:**

The NTE1869 and NTE1869SM are semiconductor integrated circuits designed for general-purpose output voltage regulation. A high-performance variable output voltage regulator with small input-output voltage differences can be made in combination with externally connected PNP transistors. These devices include a reference voltage circuit, error amplifier, and driver, and the output voltage can be set freely by externally connected resistors, and a small, compact power supply circuit can be achieved making the device suitable for use in small electronic equipment, such as car stereo, radio cassette recorder and portable stereo equipment.

**Features:**

- Wide Operating Voltage Range:  $V_{IN} = 3.5V$  to  $36V$ ,  $V_O = 1.5V$  to  $33V$
- Output Voltage can be Freely Set by Externally Connected Resistors
- Built-In ASO Protection and Thermal Cutoff Circuits
- Available in 2 Package Styles:
  - NTE1869 (Giant TO92 Type)
  - NTE1869SM (SOT-89 Surface Mount)

**Applications:**

- Car Stereo Equipment
- Radio Cassette Recorder
- Portable Stereo
- Other General Electronic Equipment

**Absolute Maximum Ratings:** ( $T_A = +25^\circ C$  unless otherwise specified)

Input Voltage, $V_{IN}$ .....	36V
Drive Current, $I_D$ .....	30mA
Input-Output Voltage Difference, $V_I - V_O$ .....	30V
Power Dissipation, $P_D$	
NTE1869 .....	900mW
NTE1869SM .....	500mW
Operating Temperature Range, $T_{opr}$ .....	$-20^\circ$ to $+75^\circ C$
Storage Temperature Range, $T_{stg}$ .....	$-55^\circ$ to $+150^\circ C$

**Recommended Operating Conditions:**

Supply Voltage Range, $V_{IN}$ .....	3.5V to 30V
Rated Supply Voltage, $V_O$ .....	1.5V to 25V

**Electrical Characteristics:** ( $T_A = +25^\circ\text{C}$ ,  $V_i = 15\text{V}$ ,  $V_o = 12\text{V}$ ,  $I_L = 200\text{mA}$ ,  $C_{\text{REF}} = 1\mu\text{F}$ ,  $R_1 = 4.3\text{k}\Omega$ , unless otherwise specified)

Parameter	Symbol	Test Conditions	Min	Typ	Max	Unit
Input Voltage	$V_{\text{IN}}$	Between Pin1 and Pin2	3.5	–	36	V
Output Voltage	$V_o$	$R_2 \square 0.82\text{k}\Omega$ to $108\text{k}\Omega$	1.5	–	33	V
Minimum Input–Output Voltage Difference	$V_i - V_o$		–	0.2	–	V
Reference Voltage	$V_{\text{REF}}$	Between Pin3 and Pin2	1.20	1.26	1.32	V
Input Regulation	$R_{\text{eg-In}}$	$V_i = 15\text{V}$ to $20\text{V}$	–	0.02	0.1	%/V
Load Regulation	$R_{\text{eg-L}}$	$I_L = 10\text{mA}$ to $200\text{mA}$	–	0.02	0.1	%
Bias Current	$I_B$	$I_L = 0$ (disregarding the current in resistors $R_1, R_2$ )	–	1.7	3.0	mA
Temperature Coefficient of Output Voltage	$\text{TC}_{V_o}$	$T_A = 0^\circ$ to $+75^\circ\text{C}$	–	0.02	–	%/°C
Ripple Rejection Ratio	RR	$f = 120\text{Hz}$	–	68	–	dB
Output Noise Voltage	$V_{\text{NO}}$	$f = 20\text{Hz}$ to $100\text{kHz}$	–	33	–	$\mu\text{V}_{\text{rms}}$

**NTE1869**

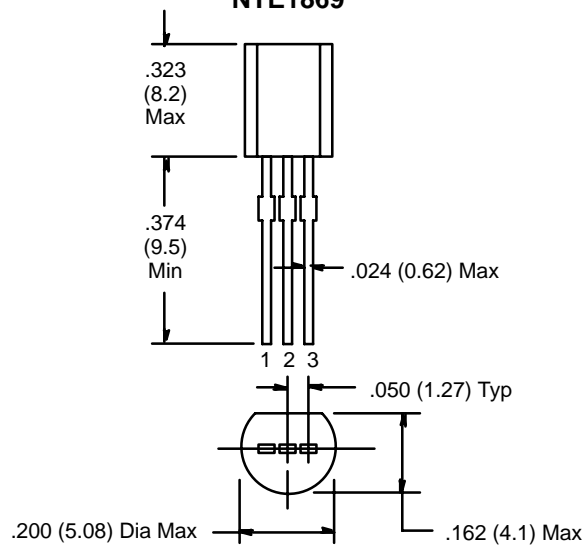

Pin 1. Input  
2. GND  
3. Reference

**NTE1869SM**

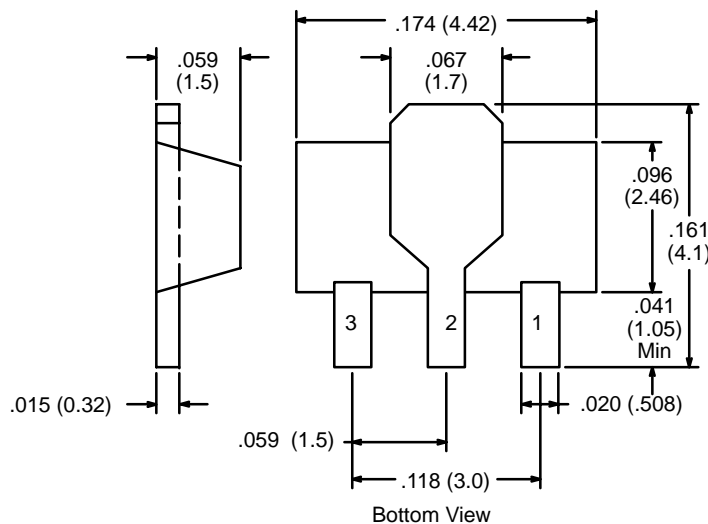

Pin 1. Reference  
2. GND  
3. Input

## X-ON Electronics

Largest Supplier of Electrical and Electronic Components

*Click to view similar products for [Linear Voltage Regulators](#) category:*

*Click to view products by [NTE](#) manufacturer:*

Other Similar products are found below :

[LV56831P-E](#) [LV5684PVD-XH](#) [MAX202ECWE-LF](#) [MCDTSA6-2R](#) [L4953G](#) [L7815ACV-DG](#) [PQ3DZ53U](#) [LV56801P-E](#)  
[TCR3DF13,LM\(CT](#) [TCR3DF39,LM\(CT](#) [TLE42794G](#) [L78L05CZ/1SX](#) [L78LR05DL-MA-E](#) [L78MR05-E](#) [033150D](#) [033151B](#) [090756R](#)  
[636416C](#) [NCV78M15BDTG](#) [702482B](#) [714954EB](#) [TLE42794GM](#) [TLE42994GM](#) [ZMR500QFTA](#) [BA033LBSG2-TR](#)  
[NCV78M05ABDTRKG](#) [NCV78M08BDTRKG](#) [NCP7808TG](#) [NCV571SN12T1G](#) [LV5680P-E](#) [CAJ24C256YI-GT3](#) [L78M15CV-DG](#) [L9474N](#)  
[TLS202B1MBV33HTSA1](#) [L79M05T-E](#) [NCP571SN09T1G](#) [MAX15006AASA/V+](#) [MIC5283-5.0YML-T5](#) [L4969URTR-E](#) [L78LR05D-MA-E](#)  
[NCV7808BDTRKG](#) [L9466N](#) [NCP7805ETG](#) [SC7812CTG](#) [NCV7809BTG](#) [NCV571SN09T1G](#) [NCV317MBTG](#) [MC78M15CDTT5G](#)  
[MC78M12CDTT5G](#) [L9468N](#)