



**ELECTRONICS, INC.**  
 44 FARRAND STREET  
 BLOOMFIELD, NJ 07003  
 (973) 748-5089  
<http://www.nteinc.com>

## NTE2696 Silicon NPN Transistor Low Noise Audio Amplifier TO-92 Type Package (Compl to NTE234)

**Description:**

The NTE2696 is a silicon NPN transistor in a TO-92 type package designed for use in low frequency and low noise applications. The function of this device is to lower the noise figure in the region of low signal source impedance, and to lower the pulse noise. The NTE2696 can also be used in the first stages of equalizer amplifiers.

**Features:**

- Low Noise:  
     NF = 4db (Typ),  $R_G = 100\Omega$ ,  $V_{CE} = 6V$ ,  $I_C = 100\mu A$ ,  $f = 1kHz$   
     NF = 0.5db (Typ),  $R_G = 1k\Omega$ ,  $V_{CE} = 6V$ ,  $I_C = 100\mu A$ ,  $f = 1kHz$
- Low Pulse Noise: Low I/f Noise
- High DC Current Gain:  $h_{FE} = 350$  to  $700$
- High Breakdown Voltage:  $V_{CEO} = 120V$

**Absolute Maximum Ratings:** ( $T_A = +25^\circ C$  unless otherwise specified)

Collector-Base Voltage, $V_{CBO}$ .....	120V
Collector-Emitter Voltage, $V_{CEO}$ .....	120V
Emitter-Base Voltage, $V_{EBO}$ .....	5V
Collector Current, $I_C$ .....	100mA
Base Current, $I_B$ .....	20mA
Collector Power Dissipation, $P_C$ .....	300mW
Operating Junction Temperature, $T_J$ .....	+125°C
Storage Temperature Range, $T_{stg}$ .....	-55° to +125°C

**Electrical Characteristics:** ( $T_A = +25^\circ C$  unless otherwise specified)

Parameter	Symbol	Test Conditions	Min	Typ	Max	Unit
Collector Cutoff Current	$I_{CBO}$	$V_{CB} = 120V, I_E = 0$	-	-	0.1	$\mu A$
Emitter Cutoff Current	$I_{EBO}$	$V_{EB} = 5V, I_C = 0$	-	-	0.1	$\mu A$
Collector-Emitter Breakdown Voltage	$V_{(BR)CEO}$	$I_C = 1mA, I_C = 2mA$	120	-	-	V



**Electrical Characteristics (Cont'd):** ( $T_A = +25^\circ\text{C}$  unless otherwise specified)

Parameter	Symbol	Test Conditions	Min	Typ	Max	Unit	
DC Current Gain	$h_{FE}$	$V_{CE} = 6\text{V}, I_C = 2\text{mA}$	350	-	700		
Collector-Emitter Saturation Voltage	$V_{CE(sat)}$	$I_C = 10\text{mA}, I_B = 1\text{mA}$	-	-	0.3	V	
Base-Emitter Voltage	$V_{BE}$	$V_{CE} = 6\text{V}, I_C = 2\text{mA}$	-	0.65	-	V	
Transition Frequency	$f_T$	$V_{CE} = 6\text{V}, I_C = 1\text{mA}$	-	100	-	MHz	
Collector Output Capacitance	$C_{ob}$	$V_{CB} = 10\text{V}, I_E = 0, f = 1\text{MHz}$	-	3.0	-	pF	
Noise Figure	NF	$V_{CE} = 6\text{V}, I_C = 0.1\text{mA}$	$f = 10\text{Hz}, R_G = 10\text{k}\Omega$	-	-	6	dB
			$f = 1\text{kHz}, R_G = 10\text{k}\Omega$	-	-	2	dB
			$f = 1\text{kHz}, R_G = 100\Omega$	-	4	-	dB

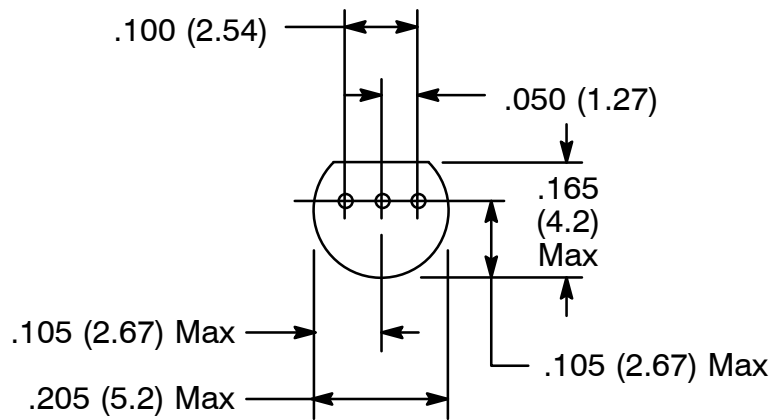
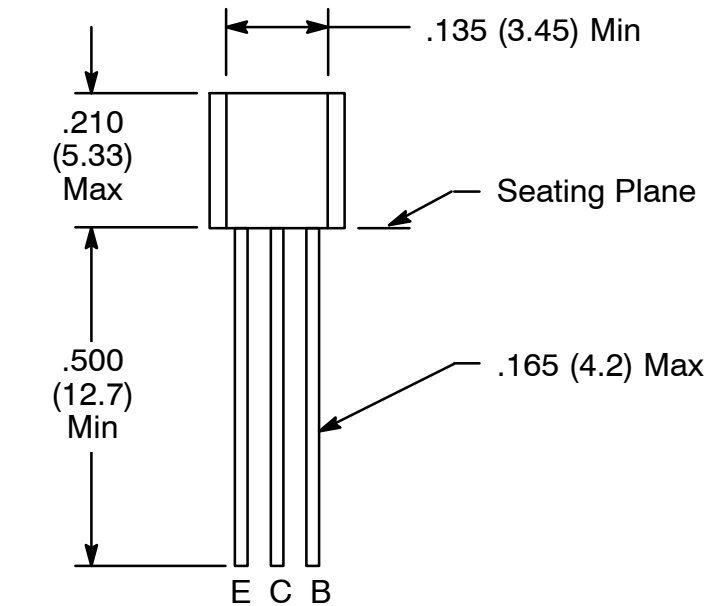

## X-ON Electronics

Largest Supplier of Electrical and Electronic Components

*Click to view similar products for [Bipolar Transistors - BJT category](#):*

*Click to view products by [NTE manufacturer](#):*

Other Similar products are found below :

[619691C](#) [MCH4017-TL-H](#) [MJ15024/WS](#) [MJ15025/WS](#) [BC546/116](#) [BC556/FSC](#) [BC557/116](#) [BSW67A](#) [HN7G01FU-A\(T5L,F,T](#)  
[NJVMJD148T4G](#) [NSVMMBT6520LT1G](#) [NTE187A](#) [NTE195A](#) [NTE2302](#) [NTE2330](#) [NTE2353](#) [NTE316](#) [IMX9T110](#) [NTE63](#) [NTE65](#)  
[C4460](#) [SBC846BLT3G](#) [2SA1419T-TD-H](#) [2SA1721-O\(TE85L,F\)](#) [2SA1727TLP](#) [2SA2126-E](#) [2SB1202T-TL-E](#) [2SB1204S-TL-E](#) [2SC5488A-](#)  
[TL-H](#) [2SD2150T100R](#) [SP000011176](#) [FMC5AT148](#) [2N2369ADCSM](#) [2SB1202S-TL-E](#) [2SC2412KT146S](#) [2SC4618TLN](#) [2SC5490A-TL-H](#)  
[2SD1816S-TL-E](#) [2SD1816T-TL-E](#) [CMXT2207 TR](#) [CPH6501-TL-E](#) [MCH4021-TL-E](#) [BC557B](#) [TTC012\(Q\)](#) [BULD128DT4](#) [JANTX2N3810](#)  
[Jantx2N5416](#) [US6T6TR](#) [KSF350](#) [068071B](#)