

## NTE478 Silicon NPN Transistor RF Power Output, $P_O = 100W @ 175MHz$

**Description:**

The NTE478 is a 12.5 Volt epitaxial silicon NPN planar transistor designed primarily for VHF communications. This device utilizes diffused emitter resistors to achieve infinite VSWR under operating conditions, and is internally input matched to optimize power gain and efficiency over the band.

**Features:**

- Designed for VHF Military and Commercial Equipment
- 100W Min with Greater than 6.0dB Gain
- Withstands Infinite VSWR under Operating Conditions
- Low Intermodulation Distortion (-32dB)
- Diffused Emitter Resistors

**Absolute Maximum Ratings:** ( $T_C = +25^\circ C$  unless otherwise specified)

Collector-Base Voltage, $V_{CBO}$ .....	36V
Collector-Emitter Voltage, $V_{CEO}$ .....	18V
Emitter-Base Voltage, $V_{EBO}$ .....	4V
Maximum Collector Current, $I_C$ .....	20A
Total Device Dissipation (At $+25^\circ C$ ), $P_{tot}$ .....	270W
Operating Junction Temperature, $T_J$ .....	$+200^\circ C$
Storage Temperature Range, $T_{stg}$ .....	$-65^\circ$ to $+150^\circ C$
Thermal Resistance, Junction-to-Case, $R_{thJC}$ .....	$65^\circ C/W$

**Electrical Characteristic:** ( $T_C = +25^\circ C$  unless otherwise specified)

Parameter	Symbol	Test Conditions	Min	Typ	Max	Unit
<b>Static</b>						
Collector-Emitter Breakdown Voltage	$V_{(BR)CEO}$	$I_C = 100mA, I_B = 0$ , Note 1	18	-	-	V
	$V_{(BR)CES}$	$I_C = 100mA, V_{BE} = 0$ , Note 1	36	-	-	V
Emitter-Base Breakdown Voltage	$V_{(BR)EBO}$	$I_E = 10mA, I_C = 0$	4	-	-	V
Collector Cutoff Current	$I_{CBO}$	$V_{CB} = 12V, I_E = 0$	-	-	10	mA
DC Current Gain	$h_{FE}$	$V_{CE} = 6V, I_C = 5A$	10	-	-	

Note 1. Pulsed through 25mH inductor.

**Electrical Characteristic (Cont'd):** ( $T_C = +25^\circ\text{C}$  unless otherwise specified)

Parameter	Symbol	Test Conditions	Min	Typ	Max	Unit
<b>Static</b>						
Output Power	$P_O$	$V_{CE} = 12.5\text{V}, f = 175\text{MHz}$	100	–	–	W
Power Gain	$P_G$	$V_{CE} = 12.5\text{V}, f = 175\text{MHz}$	6	7	–	dB
Impedance	$Z_s$	$V_{CE} = 12.5\text{V}, P_i = 20\text{W}, f = 175\text{MHz}$	–	$1.5 - j0.9$	–	$\Omega$
	$Z_{cl}$		–	$0.5 - j0.1$	–	$\Omega$
Output Capacitance	$C_{ob}$	$V_{CB} = 12\text{V}, I_E = 0, f = 1\text{MHz}$	–	354	–	pF

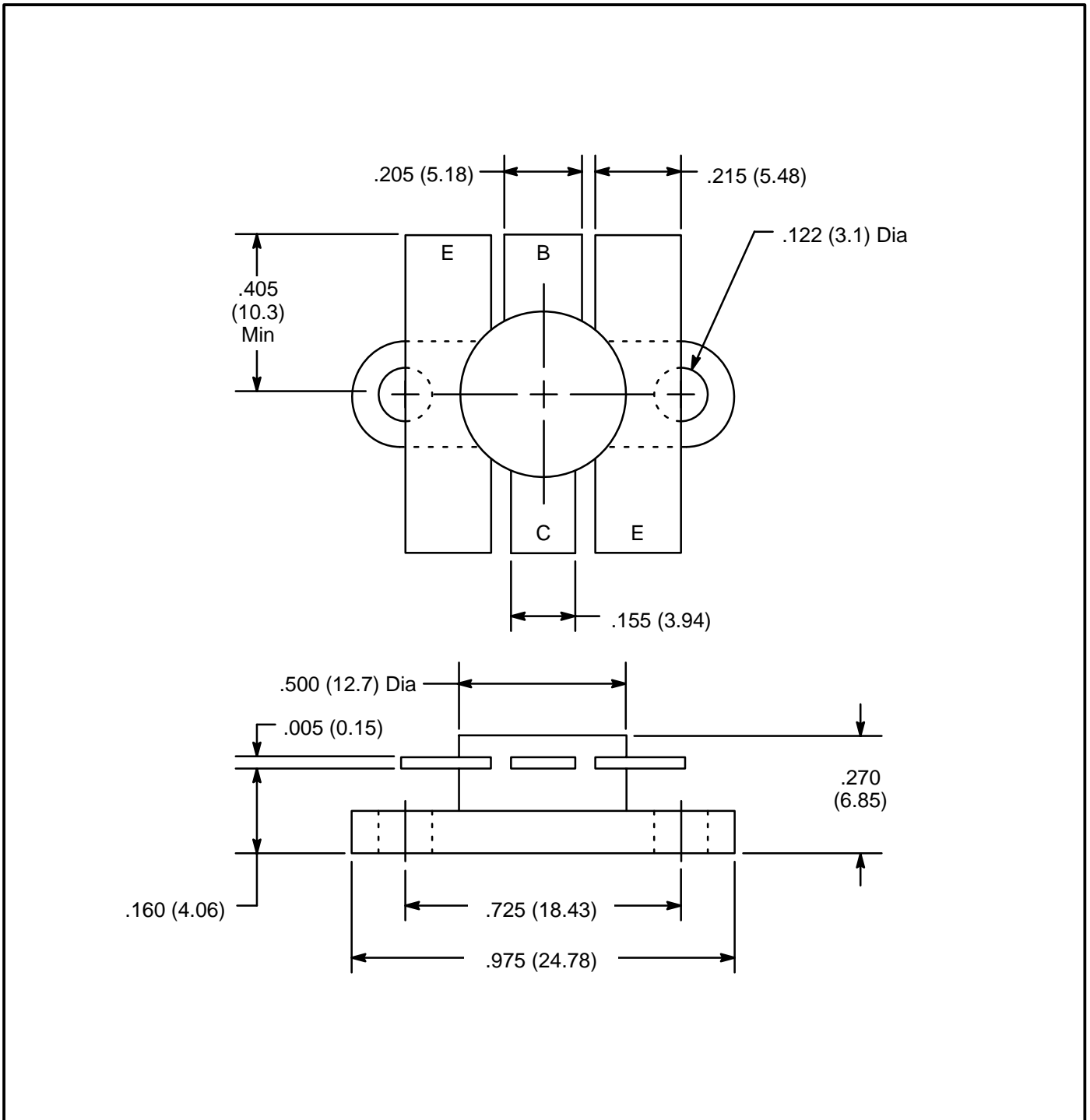

## X-ON Electronics

Largest Supplier of Electrical and Electronic Components

*Click to view similar products for [Bipolar Transistors - BJT category](#):*

*Click to view products by [NTE manufacturer](#):*

Other Similar products are found below :

[619691C](#) [MCH4017-TL-H](#) [MJ15024/WS](#) [MJ15025/WS](#) [BC546/116](#) [BC556/FSC](#) [BC557/116](#) [BSW67A](#) [HN7G01FU-A\(T5L,F,T](#)  
[NJVMJD148T4G](#) [NSVMMBT6520LT1G](#) [NTE187A](#) [NTE195A](#) [NTE2302](#) [NTE2330](#) [NTE2353](#) [NTE316](#) [IMX9T110](#) [NTE63](#) [NTE65](#)  
[C4460](#) [SBC846BLT3G](#) [2SA1419T-TD-H](#) [2SA1721-O\(TE85L,F\)](#) [2SA1727TLP](#) [2SA2126-E](#) [2SB1202T-TL-E](#) [2SB1204S-TL-E](#) [2SC5488A-](#)  
[TL-H](#) [2SD2150T100R](#) [SP000011176](#) [FMC5AT148](#) [2N2369ADCSM](#) [2SB1202S-TL-E](#) [2SC2412KT146S](#) [2SC4618TLN](#) [2SC5490A-TL-H](#)  
[2SD1816S-TL-E](#) [2SD1816T-TL-E](#) [CMXT2207 TR](#) [CPH6501-TL-E](#) [MCH4021-TL-E](#) [BC557B](#) [TTC012\(Q\)](#) [BULD128DT4](#) [JANTX2N3810](#)  
[Jantx2N5416](#) [US6T6TR](#) [KSF350](#) [068071B](#)