



ELECTRONICS, INC.
 44 FARRAND STREET
 BLOOMFIELD, NJ 07003
 (973) 748-5089

NTE7005 Integrated Circuit 2-Phase Stepping Motor Driver

Description:

The NTE7005 monolithic power IC is a dual bridge driver in a 16-Lead DIP type package. The maximum driving current and voltage is 330mA x 12V per bridge. Therefore, the best use for this part is in a two-phase bipolar stepping motor driving the head actuator of a 3, to 5.25-inch Floppy Disk Drive.

Features:

- 330mA Output Current Capability
- Dual Bridge Included
- Power Save
- Single Input Direction Control
- Low Output Saturation Voltage
- Low Supply Current
- Low Input Current
- Compatible with TTL, LSTTL, and 5V CMOS
- Thermal Shutdown

Absolute Maximum Ratings: ($T_A = +25^\circ\text{C}$, Note 1 unless otherwise specified)

Logic Stage Supply Voltage, V_{CC}	7V
Seeking Supply Voltage, V_{S1}	15V
Holding Supply Voltage, V_{S2}	7V
Input Voltage, V_i	0 to V_{CC}
Peak Seeking Current ($t \leq 5\text{ms}$), $I_o(\text{peak})$	500mA
DC Seeking Current, I_{oS}	330mA
DC Holding current, I_{OH}	200mA
Power Dissipation (Note 2), P_T	2W
Junction Temperature, T_J	+150°C
Operating Junction Temperature Range, T_{opr}	-20° to +125°C
Storage Temperature Range, T_{stg}	-55° to +125°C

Note 1. The absolute maximum ratings are limiting values, to be applied individually, beyond which the device may be permanently damaged. Functional operation under any of these conditions is not guaranteed. Exposing a circuit to its absolute maximum rating for extended periods of time may affect the device's reliability.

Note 2. Thermal resistance is as follows:

- $R_{thJA1} \leq +60^\circ\text{C/W}$ (Soldered on a print circuit board)
- $R_{thJA2} \leq +35^\circ\text{C/W}$ (Soldered on a print circuit covered with copper sufficiently)
- $R_{thJA3} \leq +15^\circ\text{C/W}$ (Soldered on Pin4, Pin5, Pin12, and Pin13 with an infinite heat sink)

Recommended Operating Conditions:

Parameter	Symbol	Test Conditions	Min	Typ	Max	Unit
Logic Stage Supply Voltage	V_{CC}		4.5	5.0	5.5	V
Seeking Supply Voltage	V_{S1}		10.2	12.0	13.8	V
Holding Supply Voltage	V_{S2}		4.5	5.0	5.5	V

Electrical Characteristics: ($T_A = +25^\circ\text{C}$, $V_{CC} = 5\text{V}$, $V_{S2} = 5\text{V}$, $V_{S1} = 12\text{V}$ unless otherwise specified)

Parameter	Symbol	Test Conditions	Min	Typ	Max	Unit	
Input Low Voltage	V_{IL}		–	–	0.8	V	
Input High Voltage	V_{IH}		2.0	–	–	V	
Input Low Current	I_{IL}	$V_I = 0.8\text{V}$	–	–	± 10	μA	
Input High Current	I_{IH}	$V_I = 2\text{V}$	–	1.0	± 10	μA	
		$V_I = 5.5\text{V}$	–	0.5	1.0	mA	
Supply Current	I_{CC}	$PS = 0.8\text{V}$, $I_o = 0$	V_{CC}	–	25	33	mA
			V_{S1} , Note 3	–	10	20	mA
			V_{S2} , Note 4	–	–	1.0	mA
		$PS = 2\text{V}$, $I_o = 0$	V_{CC}	–	25	33	mA
			V_{S1} , Note 3	–	3	5	mA
			V_{S2} , Note 4	–	5	10	mA
Output Transistor Breakdown Voltage	$V_{(BR)CE R}$	$I_C = 10\text{mA}$	18	–	–	V	
V_{S1} Saturation Voltage	$V_{CE(sat)1}$	$PS = 0.8\text{V}$, $I_o = 330\text{mA}$, Note 5	–	1.5	2.0	V	
V_{S2} Saturation Voltage	$V_{CE(sat)2}$	$PS = 2\text{V}$, $I_o = 130\text{mA}$, Note 5	–	1.5	2.0	V	
Clamp Diode Forward Voltage	V_F	$I_F = 330\text{mA}$	Upper	–	5	–	V
			Lower	–	1.5	–	V
Delay Time	t_{PLH}	$I_o = 330\text{mA}$	–	1	5	μs	
	t_{PHL}		–	1	5	μs	

Note 3. Sum of $V_{S1}(\phi 1)$ and $V_{S1}(\phi 2)$ current

Note 4. Sum of $V_{S2}(\phi 1)$ and $V_{S2}(\phi 2)$ current

Note 5. Sum of upper and lower saturation voltages

Truth Table (For each bridge):

Power Save Direction		ΦOut	$\bar{\Phi}\text{Out}$
L	L	L	H+
L	H	H+	L
H	L	L	H–
H	H	H–	L

Note: L = Low voltage state
 H+ = High voltage state
 (Seeking transistors ON)
 H– = High voltage state
 (Holding transistors ON)

Pin Connection Diagram

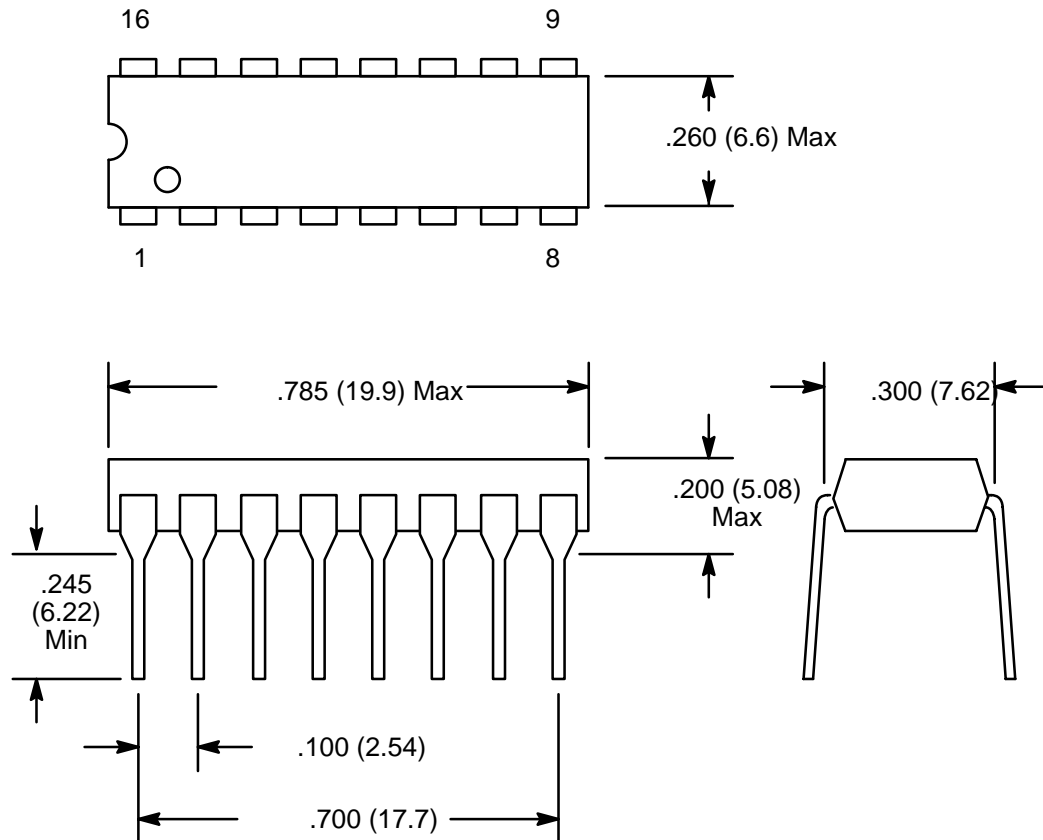
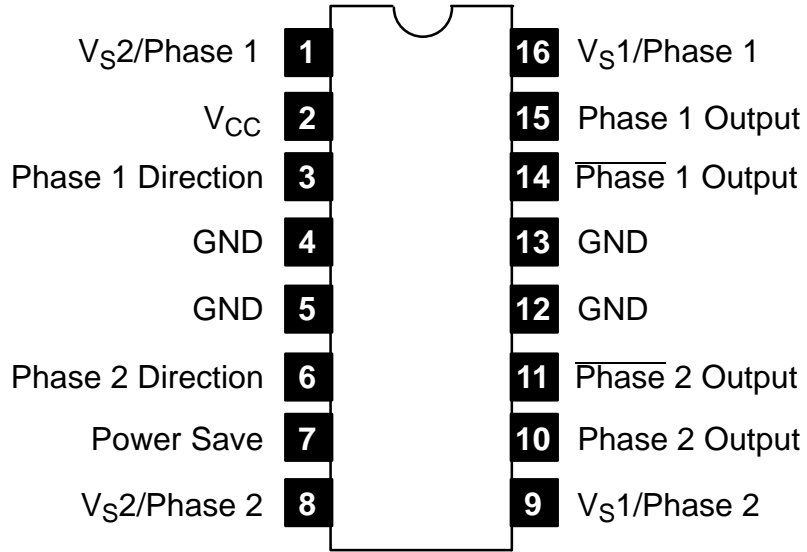

X-ON Electronics

Largest Supplier of Electrical and Electronic Components

Click to view similar products for [Motor/Motion/Ignition Controllers & Drivers](#) category:

Click to view products by [NTE manufacturer](#):

Other Similar products are found below :

[LV8133JA-ZH](#) [LV8169MUTBG](#) [LV8774Q-AH](#) [LV8860PV-TLM-H](#) [MC33931EKR2](#) [MC34GD3000EP](#) [FSB50250UTD](#) [FSB50550TB2](#)
[FSBF15CH60BTH](#) [MP6507GR-P](#) [MP6508GF](#) [MSVCPM2-63-12](#) [MSVGW45-14-2](#) [MSVGW54-14-5](#) [NTE7043](#) [CAT3211MUTAG](#)
[LA6245P-CL-TLM-E](#) [LA6245P-TLM-E](#) [LA6565VR-TLM-E](#) [LB11650-E](#) [LB1694N-E](#) [LB1837M-TLM-E](#) [LB1845DAZ-XE](#) [LC898111AXB-](#)
[MH](#) [LC898300XA-MH](#) [SS30-TE-L-E](#) [STK531-345A-E](#) [STK581U3A0D-E](#) [STK58AUNP0D-E](#) [STK621-068C-E](#) [STK621-140C](#) [STK621-](#)
[728S-E](#) [STK625-728-E](#) [STK672-400B-E](#) [STK672-432AN-E](#) [STK672-432BN-E](#) [STK672-440AN-E](#) [STK672-442AN-E](#) [AMIS30621AUA](#)
[FSB50550ASE](#) [26700](#) [LV8161MUTAG](#) [LV8281VR-TLM-H](#) [LV8702V-TLM-H](#) [LV8734VZ-TLM-H](#) [LV8773Z-E](#) [LV8807QA-MH](#)
[MC33932EK](#) [MCP8024T-H/MP](#) [TND027MP-AZ](#)