



ELECTRONICS, INC.  
 44 FARRAND STREET  
 BLOOMFIELD, NJ 07003  
 (973) 748-5089  
<http://www.nteinc.com>

## NTE7486 Integrated Circuit TTL – Quad 2-Input Exclusive-OR Gate

**Absolute Maximum Ratings:** (Note 1)

Supply Voltage, $V_{CC}$ .....	7V
Input Voltage .....	5.5V
Total Power Dissipation .....	150mW
Operating Temperature Range, $T_A$ .....	0°C to +70°C
Storage Temperature Range, $T_{stg}$ .....	-65°C to +150°C

Note 1. Voltage values are with respect to network ground terminal.

**Recommended Operating Conditions:**

Parameter	Symbol	Min	Typ	Max	Unit
Supply Voltage	$V_{CC}$	4.75	5.0	5.25	V
High-Level Output Current	$I_{OH}$	-	-	-800	$\mu$ A
Low-Level Output Current	$I_{OL}$	-	-	16	mA
Operating Temperature Range	$T_A$	0	-	+70	°C

**Electrical Characteristics:** (Note 2, Note 3)

Parameter	Symbol	Test Conditions	Min	Typ	Max	Unit
High-Level Voltage	$V_{IH}$		2	-	-	V
Low-Level Voltage	$V_{IL}$		-	-	0.8	V
Input Clamp Voltage	$V_{IK}$	$V_{CC} = \text{MIN}, I_I = -8\text{mA}$	-	-	-1.5	V
High-Level Output Voltage	$V_{OH}$	$V_{CC} = \text{MIN}, V_{IH} = 2\text{V}, V_{IL} = 0.8\text{V}, I_{OH} = -800\mu\text{A}$	2.4	3.4		V
Low-Level Output Voltage	$V_{OL}$	$V_{CC} = \text{MIN}, V_{IH} = 2\text{V}, V_{IL} = 0.8\text{V}, I_{OL} = 16\text{mA}$	-	0.2	0.4	V
Input Current	$I_I$	$V_{CC} = \text{MAX}, V_I = 5.5\text{V}$	-	-	1	mA
High-Level Input Current	$I_{IH}$	$V_{CC} = \text{MAX}, V_I = 2.4\text{V}$	-	-	40	$\mu$ A
Low-Level Input Current	$I_{IL}$	$V_{CC} = \text{MAX}, V_I = 0.4\text{V}$	-	-	-16	mA
Short-Circuit Output Current	$I_{OS}$	$V_{CC} = \text{MAX}, \text{Note 4}$	-18	-	-55	mA
Supply Current	$I_{CC}$	$V_{CC} = \text{MAX}, \text{Note 5}$	-	30	50	mA

Note 2. For conditions shown as MIN or MAX, use the appropriate value specified under “Recommended Operation Conditions”.

Note 3. All typical values are at  $V_{CC} = 5\text{V}, T_A = +25^\circ\text{C}$ .

Note 4. Not more than one output should be shorted at a time.

Note 5.  $I_{CC}$  is measured with the inputs grounded and the outputs open.

**Switching Characteristics:** ( $V_{CC} = 5V$ ,  $T_A = +25^{\circ}C$  unless otherwise specified)

Parameter	Symbol	Test Conditions	Min	Typ	Max	Unit
Propagation Delay Time (From A or B Input)	$t_{PLH}$	Other Input Low $R_L = 400\Omega$ , $C_L = 15pF$	-	15	23	ns
	$t_{PHL}$		-	11	17	ns
Propagation Delay Time (From A or B Input)	$t_{PLH}$	Other Input High	-	18	30	ns
	$t_{PHL}$		-	13	22	ns

**Function Tables:**

Inputs		Output
A	B	Y
L	L	L
L	H	H
H	L	H
H	H	L

H = High level

L = Low Level

**Pin Connection Diagram**

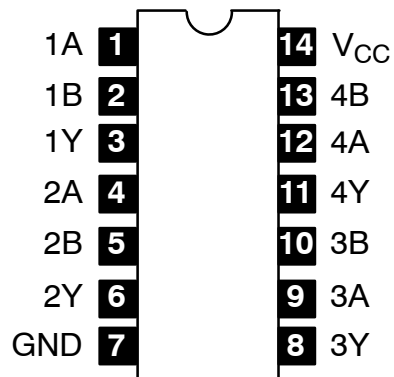

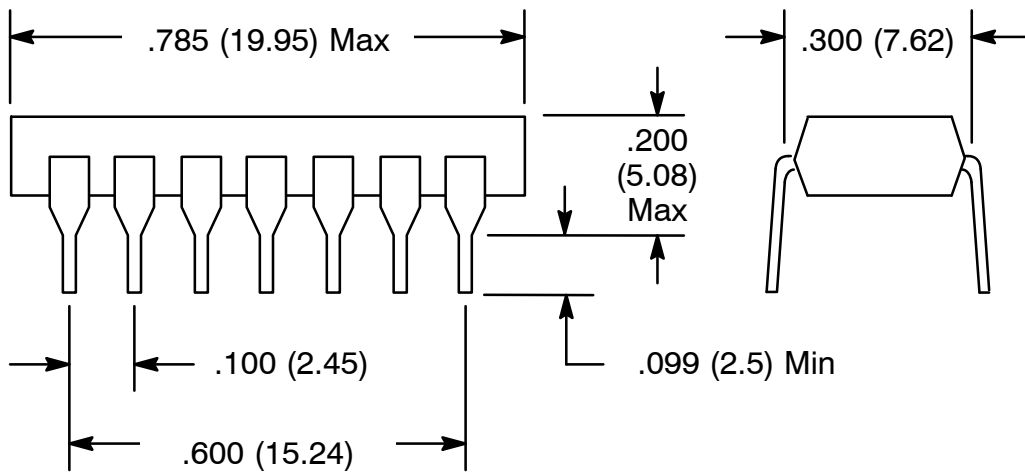
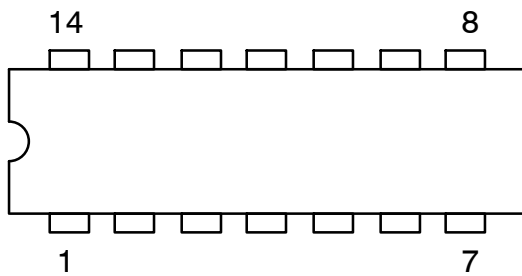

## X-ON Electronics

Largest Supplier of Electrical and Electronic Components

*Click to view similar products for [Logic Gates](#) category:*

*Click to view products by [NTE](#) manufacturer:*

Other Similar products are found below :

[5962-8769901BCA](#) [74HC85N](#) [NL17SG08P5T5G](#) [NL17SG32DFT2G](#) [NLU1G32AMUTCG](#) [NLV7SZ58DFT2G](#) [NLVHC1G08DFT1G](#)  
[NLVVHC1G14DTT1G](#) [NLX2G08DMUTCG](#) [NLX2G08MUTCG](#) [MC74HCT20ADR2G](#) [091992B](#) [091993X](#) [093560G](#) [634701C](#) [634921A](#)  
[NL17SG32P5T5G](#) [NL17SG86DFT2G](#) [NLU1G32CMUTCG](#) [NLV14001UBDR2G](#) [NLVVHC1G132DTT1G](#) [NLVVHC1G86DTT1G](#)  
[NLX1G11AMUTCG](#) [NLX1G97MUTCG](#) [746427X](#) [74AUP1G17FW5-7](#) [74LS38](#) [74LVC1G08Z-7](#) [74LVC32ADTR2G](#) [74LVC1G125FW4-7](#)  
[74LVC08ADTR2G](#) [MC74HCT20ADTR2G](#) [NLV14093BDTR2G](#) [NLV17SZ00DFT2G](#) [NLV17SZ02DFT2G](#) [NLV17SZ126DFT2G](#)  
[NLV27WZ17DFT2G](#) [NLV74HC02ADR2G](#) [NLV74HC08ADR2G](#) [NLVVHC1GT32DFT1G](#) [74HC32S14-13](#) [74LS133](#) [74LVC1G32Z-7](#)  
[M38510/30402BDA](#) [74LVC1G86Z-7](#) [74LVC2G08RA3-7](#) [M38510/06202BFA](#) [NLV74HC08ADTR2G](#) [NLV74HC14ADR2G](#)  
[NLV74HC20ADR2G](#)