



ELECTRONICS, INC.
 44 FARRAND STREET
 BLOOMFIELD, NJ 07003
 (973) 748-5089

NTE869 Integrated Circuit Dual, High Speed, Programmable Current Mode (Norton) Amp

Description:

The NTE869 consists of two current differencing (Norton) input amplifiers. Emphasis has been placed on obtaining high frequency performance and providing user programmable amplifier operating characteristics. Each amplifier is broadbanded to provide a high gain bandwidth product, fast slew rate and stable operation for an Inverting closed loop gain of 10 or greater. Pins for additional external frequency compensation are provided. The amplifiers are designed to operate from a single supply and can accommodate input common-mode voltages greater than the supply.

Applications:

- General Purpose Video Amplifiers
- High Frequency, High Q Active Filters
- Photo-Diode Amplifiers
- Wide Frequency Range Waveform Generation Circuits
- AC Applications Work to much Higher Frequencies

Features:

- User programmable gain bandwidth product, slew rate, input bias current, output stage biasing current and total device power dissipation.
- High gain bandwidth product ($I_{SET} = 0.5mA$)
 400MHz for $A_V = 10$ to 100
 30MHz for $A_V = 1$
- Current differencing inputs allow high common-mode input voltages
- Operates from a single 5V to 22V supply
- Large inverting amplifier output swing, 2mV to $V_{CC} - 2V$
- Low spot noise, $6nV/\sqrt{Hz}$, for $f > 1kHz$

Absolute Maximum Ratings:

Supply Voltage	22V
Supply Voltage	$\pm 11V$
Power Dissipation, P_D	750mW
Input Currents, $I_{IN}(+)$ or $I_{IN}(-)$	10mA
Set Currents, $I_{SET(IN)}$ or $I_{SET(OUT)}$	2mA
Maximum Junction Temperature, T_J	+125°C
Operating Temperature Range, T_{opr}	0° to 70°C
Thermal Resistance, Junction-to-Ambient, R_{thJA}	160°C/W
Lead Temperature (During Soldering, 10sec), T_L	+300°C

Electrical Characteristics: ($I_{SET(IN)} = I_{SET(OUT)} = 0.5\text{mA}$, $V_{supply} = 12\text{V}$, $T_A = +25^\circ\text{C}$ unless otherwise noted.)

Parameter	Test Conditions	Min	Typ	Max	Unit
Open Loop Voltage Gain	$V_{supply} = 12\text{V}$, $R_L = 1\text{k}$, $f = 100\text{Hz}$ $T_A = 125^\circ\text{C}$	62 –	72 68	– –	dB
Bandwidth Unity Gain	$R_{IN} = 1\text{k}\Omega$, $C_{comp} = 10\text{pF}$	15	30	–	MHz
Gain Bandwidth Product Gain of 10 to 100	$R_{IN} 50\Omega$ to 200Ω	200	400	–	MHz
Slew Rate Unity Gain Gain of 10 to 100	$R_{IN} = 1\text{k}\Omega$, $C_{comp} = 10\text{pF}$ $R_{IN} < 200\Omega$	– –	30 60	– –	V/ μs
Amplifier to Amplifier Coupling	$f = 100\text{Hz}$ to 100kHz , $R_L = 1\text{k}$	–	–80	–	dB
Mirror Gain (Note 1)	@ $2\text{mA } I_{IN(+)}$, $I_{SET} = 5\mu\text{A}$, $T_A = 25^\circ\text{C}$ @ $0.2\text{mA } I_{IN(+)}$, $I_{SET}=5\mu\text{A}$ Over Temp @ $20\mu\text{A } I_{IN(+)}$, $I_{SET} = 5\mu\text{A}$ Over Temp	0.9 0.9 0.9	1.0 1.0 1.0	1.1 1.1 1.1	$\mu\text{A}/\mu\text{A}$
Mirror Gain (Note 1)	@ $20\mu\text{A}$ to $0.2\text{mA } I_{IN(+)}$ Over Temp, $I_{SET} = 5\mu\text{A}$	–	3	5	%
Input Bias Current	Inverting Input, $T_A = 25^\circ\text{C}$ Over Temp	–	8	15	μA
Input Resistance (β_{re})	Inverting Input	–	2.5	–	$\text{k}\Omega$
Output Resistance	$I_{OUT} = 15\text{mA rms}$, $f = 1\text{MHz}$	–	3.5	–	Ω
Output Voltage Swing V_{OUT} High V_{OUT} Low	$R_L = 600\Omega$ $I_{IN(-)}$ & $I_{IN(+)}$ Grounded $I_{IN(-)} = 100\mu\text{A}$, $I_{IN(+)} = 0$	9.5 –	10.3 2.0	– 50	V mV
Output Currents Source Sink (Linear Region) Sink (Overdriven)	$I_{IN(-)}$ & $I_{IN(+)}$ Grounded, $R_L = 100\Omega$ $V_{comp} = 0.5\text{V} = V_{OUT} = 1\text{V}$, $I_{IN(+)} = 0$ $I_{IN(-)} = 100\mu\text{A}$, $I_{IN(+)} = 0$, V_{OUT} Force = 1V	16 – 1.5	40 4.7 3.0	– – –	mA
Supply Current	Non-Inverting Input Grounded, $R_L = \infty$	–	18.5	22	mA
Power Supply Rejection	$f = 120\text{Hz}$, $I_{IN(+)}$ Grounded	40	50	–	dB

Note 1. Mirror gain is the current gain of the current mirror which is used as the non-inverting input.

$$\left(A_I = \frac{I_{IN(-)}}{I_{IN(+)}} \right) \Delta_{\text{Mirror}}$$

Pin Connection Diagram

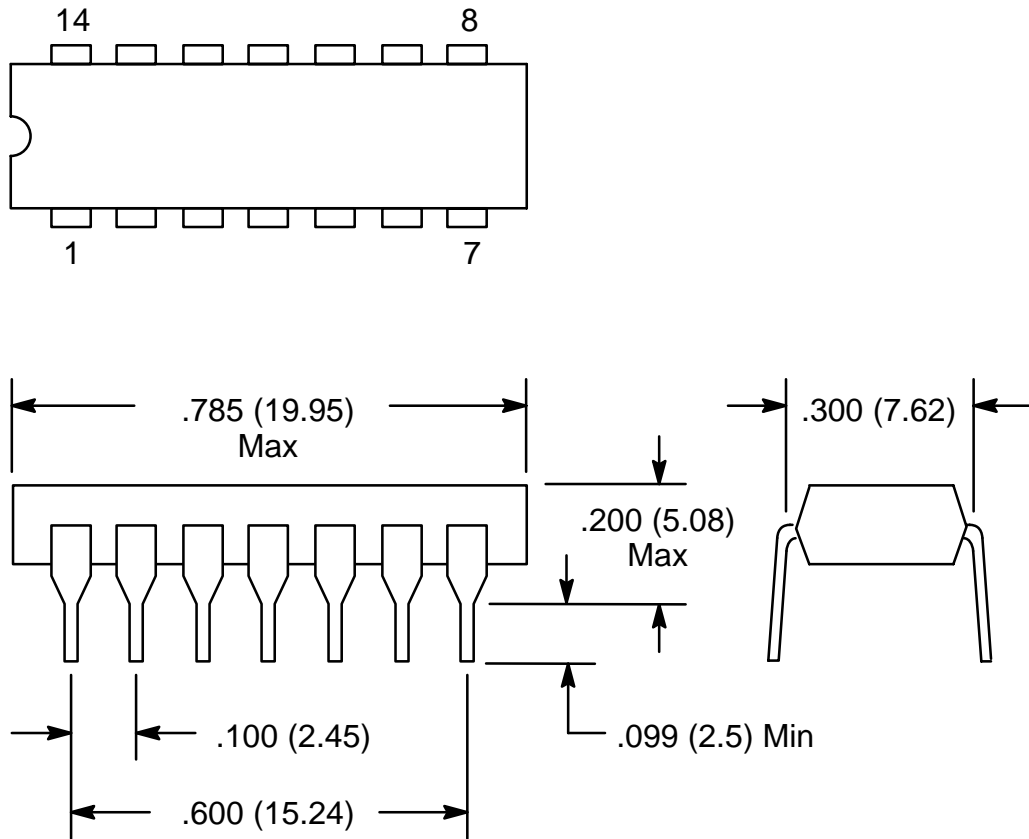
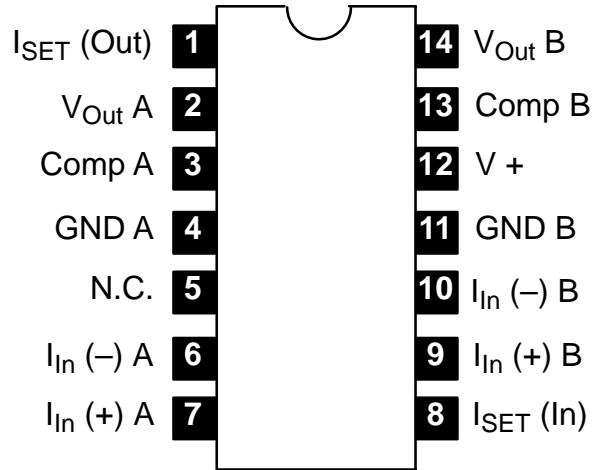

X-ON Electronics

Largest Supplier of Electrical and Electronic Components

Click to view similar products for [Operational Amplifiers - Op Amps](#) category:

Click to view products by [NTE manufacturer](#):

Other Similar products are found below :

[OPA2991IDSGR](#) [OPA607IDCKT](#) [007614D](#) [633773R](#) [635798C](#) [635801A](#) [702115D](#) [709228FB](#) [741528D](#) [NCV33072ADR2G](#) [SC2903DR2G](#)
[SC2903VDR2G](#) [LM258AYDT](#) [LM358SNG](#) [430227FB](#) [430228DB](#) [460932C](#) [AZV831KTR-G1](#) [409256CB](#) [430232AB](#) [LM2904DR2GH](#)
[LM358YDT](#) [LT1678IS8](#) [042225DB](#) [058184EB](#) [070530X](#) [714228XB](#) [714846BB](#) [873836HB](#) [MIC918YC5-TR](#) [TS912BIYDT](#)
[NCS2004MUTAG](#) [NCV33202DMR2G](#) [M38510/13101BPA](#) [NTE925](#) [SC2904DR2G](#) [SC358DR2G](#) [LM358EDR2G](#) [AZV358MTR-G1](#)
[AP4310AUMTR-AG1](#) [HA1630D02MMEL-E](#) [NJM358CG-TE2](#) [HA1630S01LPEL-E](#) [LM324AWPT](#) [HA1630Q06TELL-E](#) [NJM4558CG-TE2](#)
[AZV358MMTR-G1](#) [SCY33178DR2G](#) [NCS4325DR2G](#) [LM7301SN1T1G](#)