



ELECTRONICS, INC.
 44 FARRAND STREET
 BLOOMFIELD, NJ 07003
 (973) 748-5089

NTE902 Integrated Circuit Operational Transconductance Amplifier

Description:

The NTE902 has a differential input and a single-ended, push-pull, class A output. In addition there is a bias input for linear gain control, whose transconductance (g_m) is directly proportional to the amplifier bias current (I_{ABC}).

Features:

- Slew rate (unity gain, compensated): 50V/ μ s
- Flexible supply voltage range: $\pm 2V$ to $\pm 15V$
- Fully adjustable gain: 0 to $g_m R_L$ limit

Applications:

- Sample and hold
- Multiplex
- Voltage follower
- Multiplier
- Comparator

Absolute Maximum Ratings: ($T_A = +25^\circ C$ unless otherwise specified)

| | |
|---|-------------------------------|
| DC Supply Voltage (between V+ and V- Pins) | 36V |
| Differential Input Voltage | $\pm 5V$ |
| DC Input Voltage | V+ to V- |
| Input Signal Current | 1mA |
| Amplifier Bias Current | 2mA |
| Output Short-Circuit Duration (Note 1) | No limitation |
| Device Dissipation, P_D | 125mW |
| Operating Temperature Range, T_{op} | 0° to $+70^\circ C$ |
| Storage Temperature Range, T_{stg} | -65° to $+150^\circ C$ |
| Lead Temperature (During Soldering), T_L | |
| (At distance $1/16 \pm 1/32$ in. (1.59 ± 0.79 mm) from case for 10s max) | $+300^\circ C$ |

Note 1. Short circuit may be applied to GND or to either supply.

Electrical Characteristics: ($V_+ = 15V$, $V_- = -15V$, $I_{ABC} = 500\mu A$, $T_A = +25^\circ C$ unless otherwise specified)

| Parameter | Symbol | Test Conditions | Min | Typ | Max | Unit |
|---|----------------------------|--|-----------|---------------|-------|------------|
| Input Offset Voltage | V_{IO} | | – | 0.4 | 5.0 | mV |
| | | $T_A = 0$ to $+70^\circ C$ | – | – | 6.0 | |
| Input Offset Current | I_{IO} | | – | 0.12 | 0.6 | μA |
| Input Bias Current | I_I | | – | 2 | 5 | μA |
| | | $T_A = 0$ to $+70^\circ C$ | – | – | 7 | |
| Forward Transconductance (Large signal) | g_m | | 6700 | 9600 | 13000 | μmho |
| | | $T_A = 0$ to $+70^\circ C$ | 5400 | – | – | |
| Peak Output Current | $ I_{OM} $ | $R_L = 0$ | 350 | 500 | 650 | μA |
| | | $R_L = 0$, $T_A = 0$ to $+70^\circ C$ | 300 | – | – | |
| Peak Output Voltage: Positive Negative | V_{+OM} | $R_L = \infty$ | 12.0 | 13.5 | – | V |
| | V_{-OM} | | –12 | –14.4 | – | |
| Amplifier Supply Current | I_A | | 0.8 | 1 | 1.2 | mA |
| Device Dissipation | P_D | | 24 | 30 | 36 | mW |
| Input Offset Voltage Sensitivity: Positive Negative | $\Delta V_{IO}/\Delta V_+$ | | – | – | 150 | $\mu V/V$ |
| | $\Delta V_{IO}/\Delta V_-$ | | – | – | 150 | |
| Common-Mode Rejection Ratio | CMRR | | 80 | 110 | – | dB |
| Common-Mode Input Voltage Range | V_{ICR} | | 12 to –12 | 13.6 to –14.6 | – | V |
| Input Resistance | R_I | | 10 | 26 | – | k Ω |
| Amplifier Bias Voltage | V_{ABC} | | – | 0.71 | – | V |
| Slew Rate: Maximum (uncompensated) Unity gain (compensated) | SR | | – | 75 | – | V/ μs |
| | | | – | 50 | – | |
| Open-Loop Bandwidth | BW_{OL} | | – | 2 | – | MHz |
| Input Capacitance | C_I | $f = 1MHz$ | – | 3.6 | – | pF |
| Output Capacitance | C_O | $f = 1MHz$ | – | 5.6 | – | pF |
| Output Resistance | R_O | | – | 15 | – | M Ω |
| Input-to-Output Capacitance | C_{I-O} | $f = 1MHz$ | – | 0.024 | – | pF |

Pin Connection Diagram

Top View

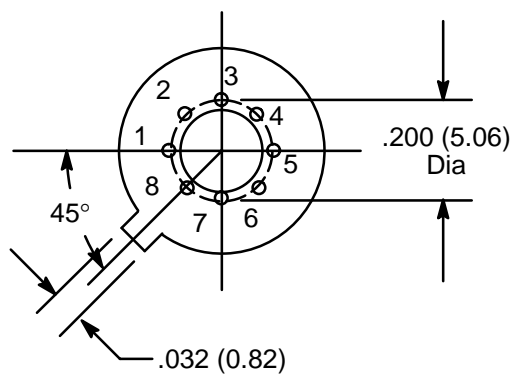
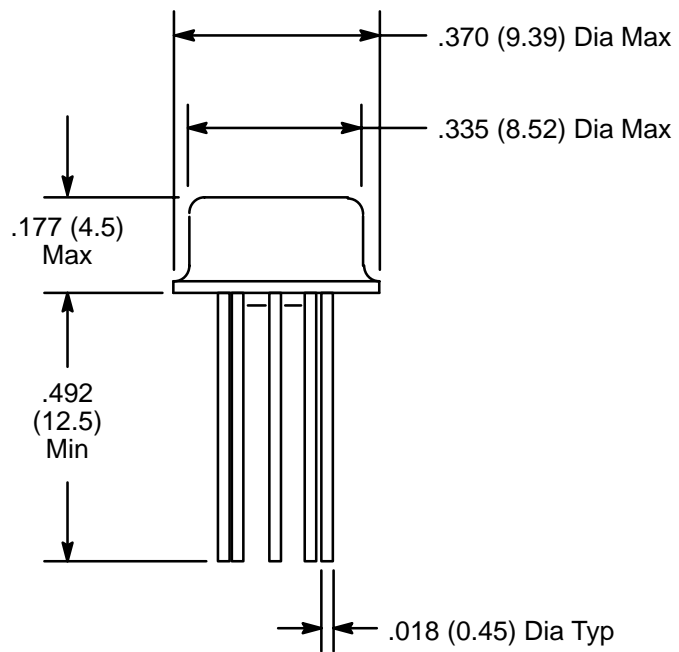
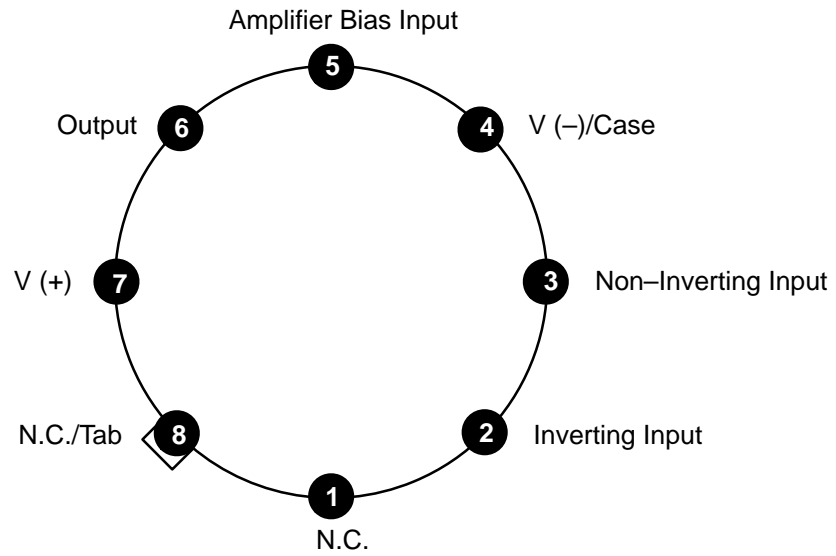

X-ON Electronics

Largest Supplier of Electrical and Electronic Components

Click to view similar products for [Operational Amplifiers - Op Amps](#) category:

Click to view products by [NTE manufacturer](#):

Other Similar products are found below :

[OPA2991IDSGR](#) [OPA607IDCKT](#) [007614D](#) [633773R](#) [635798C](#) [635801A](#) [702115D](#) [709228FB](#) [741528D](#) [NCV33072ADR2G](#) [SC2903DR2G](#)
[SC2903VDR2G](#) [LM258AYDT](#) [LM358SNG](#) [430227FB](#) [430228DB](#) [460932C](#) [AZV831KTR-G1](#) [409256CB](#) [430232AB](#) [LM2904DR2GH](#)
[LM358YDT](#) [LT1678IS8](#) [042225DB](#) [058184EB](#) [070530X](#) [714228XB](#) [714846BB](#) [873836HB](#) [MIC918YC5-TR](#) [TS912BIYDT](#)
[NCS2004MUTAG](#) [NCV33202DMR2G](#) [M38510/13101BPA](#) [NTE925](#) [SC2904DR2G](#) [SC358DR2G](#) [LM358EDR2G](#) [AZV358MTR-G1](#)
[AP4310AUMTR-AG1](#) [HA1630D02MMEL-E](#) [NJM358CG-TE2](#) [HA1630S01LPEL-E](#) [LM324AWPT](#) [HA1630Q06TELL-E](#) [NJM4558CG-TE2](#)
[AZV358MMTR-G1](#) [SCY33178DR2G](#) [NCS4325DR2G](#) [LM7301SN1T1G](#)