



ELECTRONICS, INC.

44 FARRAND STREET
BLOOMFIELD, NJ 07003
(973) 748-5089
<http://www.nteinc.com>

NTE918 NTE918M NTE918SM Integrated Circuit High Speed Operational Amplifier

Description:

The NTE918, NTE918M, and the NTE918SM are precision high speed operational amplifier designed for applications requiring wide bandwidth and high slew rate. These devices have internal unity gain frequency compensation. This considerably simplifies its application since no external components are necessary for operation. However, unlike most internally compensated amplifiers, external frequency compensation may be added for optimum performance. For inverting applications, feed-forward compensation will boost the slew rate to over 150V/ μ s and almost double the bandwidth. Overcompensation can be used with the amplifier for greater stability when maximum bandwidth is not needed. Further, a single capacitor can be added to reduce the 0.1% setting time to under 1 μ s. The high speed and fast setting time of these OP amps make them useful in A/D converters, oscillators, active filters, sample and hold circuits, or general purpose amplifiers. These devices are easy to apply and offer an order of magnitude better AC performance than industry standards such as the NTE909 and NTE909D.

Features:

- 15MHz Small Signal Bandwidth
- Guaranteed 50V/ μ s Slew Rate
- Maximum Bias Current of 250nA
- Operates from Supplies of \pm 5V to \pm 20V
- Internal Frequency Compensation
- Input and Output Overload Protected
- Pin Compatible with General Purpose OP Amps
- Available in 3 Different Case Styles:
 - 8-Lead Metal Can: NTE918
 - 8-Lead Mini DIP: NTE918M
 - 8-Lead SOIC (Surface Mount): NTE918SM

Absolute Maximum Ratings:

Power Supply Voltage, V_S	$\pm 20V$
Power Dissipation (Note 2), P_D	500mW
Differential Input Current (Note 3), I_{ID}	$\pm 10mA$
Input Voltage (Note 4), V_I	$\pm 15V$
Output Short-Circuit Duration, t_S	Indefinite
Operating Temperature Range, T_{opr}	0° to $+70^\circ C$
Storage Temperature Range, T_{stg}	-65° to $+150^\circ C$
Lead Temperature (During Soldering, 10sec), T_L	
NTE918 (Metal Can)	$+300^\circ C$
NTE918M (Plastic DIP)	$+260^\circ C$
NTE918SM (Surface Mount)	
Vapor Phase (60sec)	$+215^\circ C$
Infrared (15sec)	$+220^\circ C$

Note 1. **NTE918** is a **discontinued** device and **no longer available**.

Note 2. The maximum junction temperature of these devices is $+110^\circ C$. For operating at elevated temperatures, the NTE918 must be derated based on a thermal resistance of $+150^\circ C/W$, junction to ambient, or $+45^\circ C/W$, junction to case. The thermal resistance of the NTE918M and the NTE918SM is $+100^\circ C/W$, junction to ambient.

Note 3. The inputs are shunted with back-to-back diodes for overvoltage protection. Therefore, excessive current will flow if a differential input voltage in excess of 1V is applied between the inputs unless some limiting resistance is used.

Note 4. For supply voltages less than $\pm 15V$, the absolute maximum input voltage is equal to the supply voltage.

Electrical Characteristics: ($\pm 5V \leq V_S \leq \pm 20V$, $0^\circ \leq T_A \leq +70^\circ C$, Note 5 unless otherwise specified)

Parameter	Symbol	Test Conditions	Min	Typ	Max	Unit
Input Offset Voltage	V_{IO}		–	–	15	V
		$T_A = +25^\circ C$	–	4	10	V
Input Offset Current	I_{IO}		–	–	300	nA
		$T_A = +25^\circ C$	–	30	200	nA
Input Bias Current	I_{IB}		–	–	750	nA
		$T_A = +25^\circ C$	–	150	500	nA
Input Resistance	r_i	$T_A = +25^\circ C$	0.5	3.0	–	$M\Omega$
Supply Current	I_{CC}, I_{EE}	$T_A = +25^\circ C$	–	5	10	mA
Large Signal Voltage Gain	A_V	$V_S = \pm 15V, V_{OUT} = \pm 10V, R_L \geq 2k\Omega$	20	–	–	V/mV
		$V_S = \pm 15V, V_{OUT} = \pm 10V, R_L \geq 2k\Omega, T_A = +25^\circ C$	25	200	–	V/mV
Slew Rate	SR	$V_S = \pm 15V, A_V = 1, T_A = +25^\circ C$, Note 6	50	70	–	V/ μs
Small Signal Bandwidth	BW	$V_S = \pm 15V, T_A = +25^\circ C$	–	15	–	MHz
Output Voltage Swing	V_O	$V_S = \pm 15V, R_L = 2k\Omega$	± 12	± 13	–	V
Input Voltage Range	V_I	$V_S = \pm 15V$	± 11.5	–	–	V
Common-Mode Rejection Ratio	CMRR		100	–	–	dB
Supply Voltage Rejection Ratio	PSRR		65	80	–	dB

Note 5. Power supplies must be bypassed with 0.1 μF disc capacitors.

Note 6. Slew rate is tested with $V_S = \pm 15V$. These devices are in a unity-gain non-inverting configuration. V_{IN} is stepped from $-7.5V$ to $+7.5V$ and vice versa. The slew rates between $-5V$ and $+5V$ and vice versa are tested and guaranteed to exceed 50V/ μs .

Pin Connection Diagram

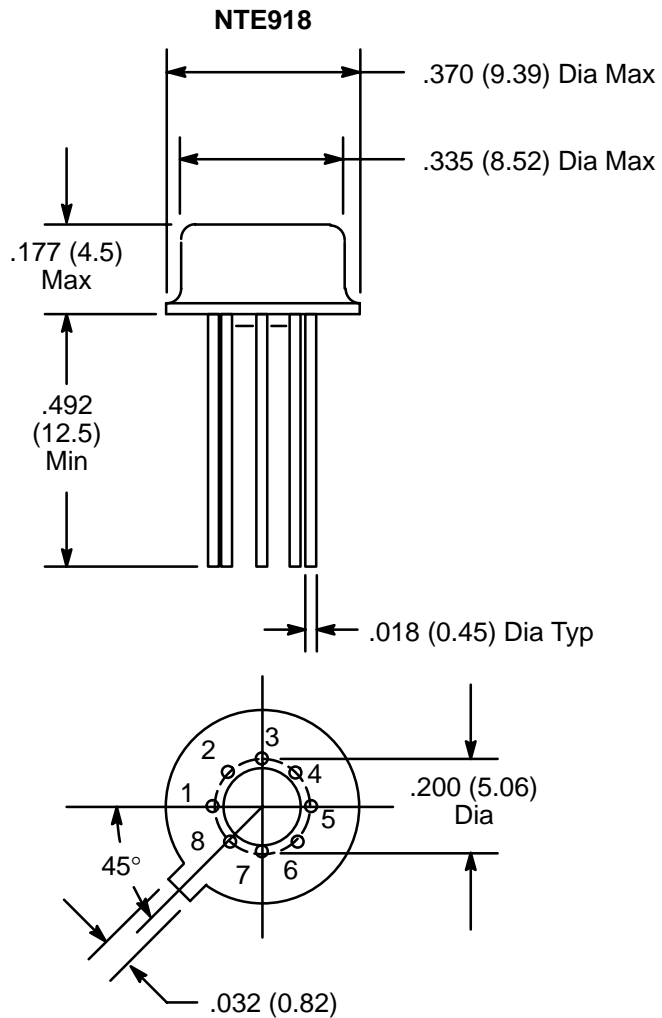
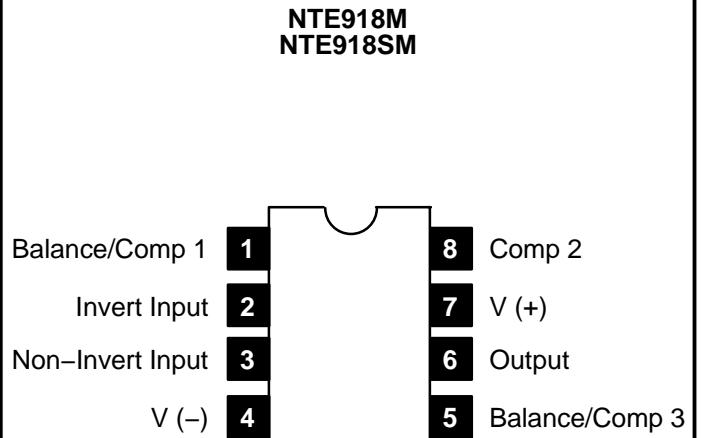
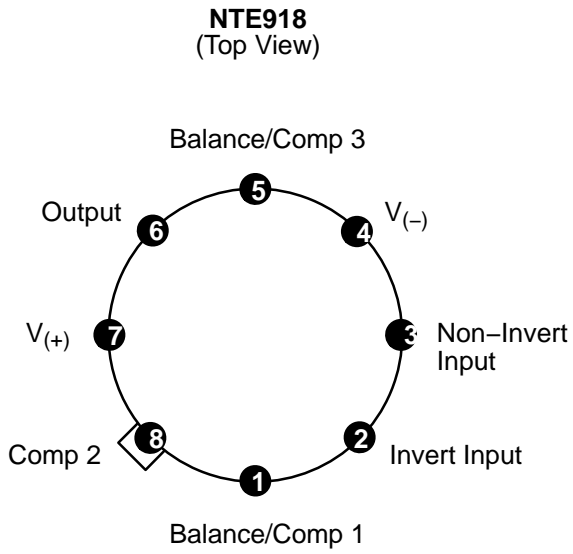

NTE918M

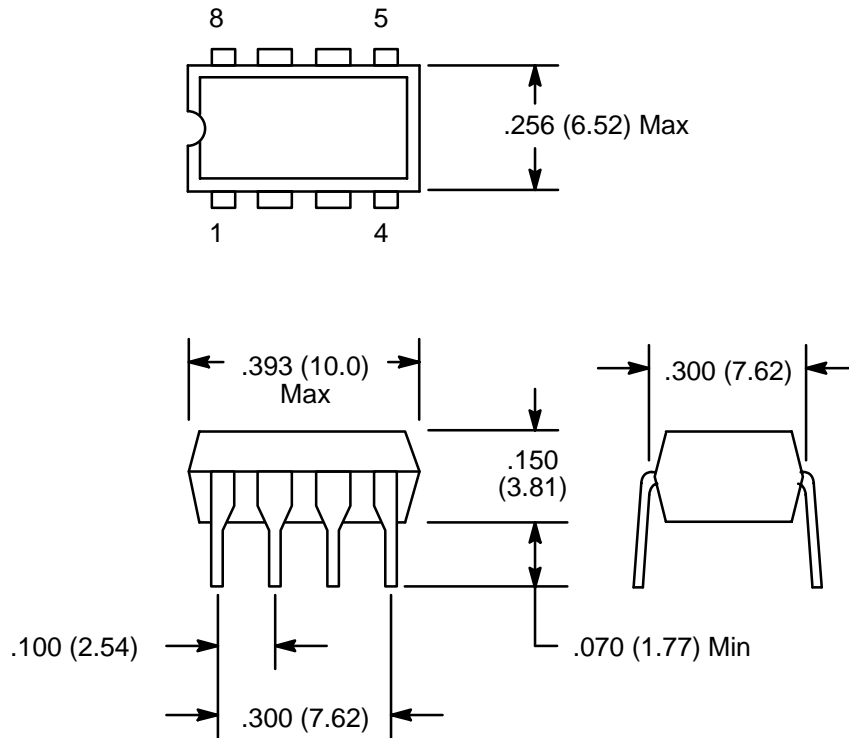

NTE918SM

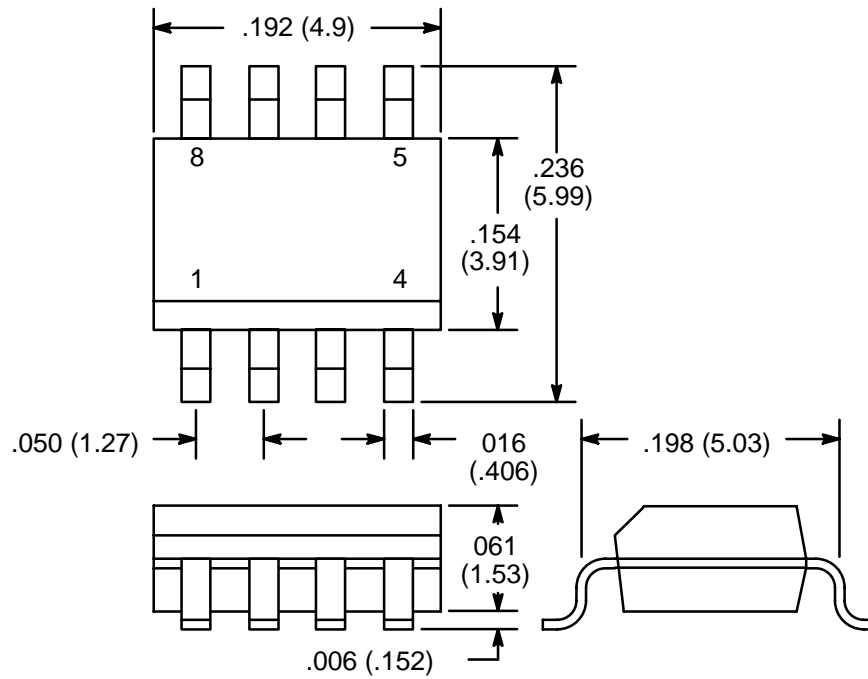

NOTE: Pin1 on Beveled Edge

X-ON Electronics

Largest Supplier of Electrical and Electronic Components

Click to view similar products for [Operational Amplifiers - Op Amps](#) category:

Click to view products by [NTE manufacturer](#):

Other Similar products are found below :

[OPA2991IDSGR](#) [OPA607IDCKT](#) [007614D](#) [633773R](#) [635798C](#) [635801A](#) [702115D](#) [709228FB](#) [741528D](#) [NCV33072ADR2G](#) [SC2903DR2G](#)
[SC2903VDR2G](#) [LM258AYDT](#) [LM358SNG](#) [430227FB](#) [430228DB](#) [460932C](#) [AZV831KTR-G1](#) [409256CB](#) [430232AB](#) [LM2904DR2GH](#)
[LM358YDT](#) [LT1678IS8](#) [042225DB](#) [058184EB](#) [070530X](#) [714228XB](#) [714846BB](#) [873836HB](#) [MIC918YC5-TR](#) [TS912BIYDT](#)
[NCS2004MUTAG](#) [NCV33202DMR2G](#) [M38510/13101BPA](#) [NTE925](#) [SC2904DR2G](#) [SC358DR2G](#) [LM358EDR2G](#) [AZV358MTR-G1](#)
[AP4310AUMTR-AG1](#) [HA1630D02MMEL-E](#) [NJM358CG-TE2](#) [HA1630S01LPEL-E](#) [LM324AWPT](#) [HA1630Q06TELL-E](#) [NJM4558CG-TE2](#)
[AZV358MMTR-G1](#) [SCY33178DR2G](#) [NCS4325DR2G](#) [LM7301SN1T1G](#)