



ELECTRONICS, INC.
 44 FARRAND STREET
 BLOOMFIELD, NJ 07003
 (973) 748-5089
<http://www.nteinc.com>

NTE937

Integrated Circuit

JFET Input Operational Amplifier

Description:

The NTE937 is a monolithic JFET input operational amplifier in an 8-Lead Metal Can type package incorporating well-matched, high voltage JFET's on the same chip with standard bi-polar transistors. This amplifier features low input bias and offset currents, low offset voltage and offset voltage drift, coupled with offset adjust which does not degrade drift or common-mode rejection. It is also designed for high slew rate, wide bandwidth, extremely fast settling time, low voltage and current noise and a low 1/f noise corner.

Advantages:

- Replaces Expensive Hybrid and Module FET OP Amps
- Rugged JFET's Allow Blow-Out Free Handling Compared with MOSFET Input Device
- Excellent for Low Noise Applications using either High or Low Source Impedance – Very Low 1/f Corner
- Offset Adjust does not Degrade Drift or Common-Mode Rejection as in Most Monolithic Amplifiers
- New Output Stage Allows use of Large Capacitive Loads (10,000pF) without Stability Problems
- Internal Compensation and Large Differential Input Voltage Capability

Applications:

- Precision High Speed Integrators
- Fast D/A and A/D Converters
- High Impedance Buffers
- Wideband, Low Noise, Low Drift Amplifiers
- Logarithmic Amplifiers
- Photocell Amplifiers
- Sample and Hold Circuits

Absolute Maximum Ratings:

Supply Voltage	±18V
Maximum Power Dissipation (at +25°C, Note 1), P _d	570mW
Differential Input Voltage	±30V
Input Voltage Range (Note 2)	±16V
Output Short-Circuit Duration	Continuous
Maximum Operating Junction Temperature (Note 1), T _{Jmax}	+115°C
Storage Temperature Range, T _{stg}	-65° to +150°C
Lead Temperature (During Soldering, 10sec), T _L	+300°C
Thermal Resistance, Junction-to-Ambient (Note 1), R _{thJC}	+150°C/W

Note 1. The maximum power dissipation for this device must be derated at elevated temperatures and is dictated by T_{Jmax}, R_{thJC}, and the ambient temperature, T_A. The maximum available power dissipation at any temperature is P_d = (T_{Jmax} - T_A)/R_{thJC} or the +25°C P_{dmax}, whichever is less.

Note 2. Unless otherwise specified, the absolute maximum negative input voltage is equal to the negative power supply voltage.

DC Electrical Characteristics: ($T_A = +25^\circ\text{C}$, $V_S = \pm 15\text{V}$ unless otherwise specified)

Parameter	Symbol	Test Conditions	Min	Typ	Max	Unit
Supply Current	I_{CC}		–	5	10	mA

DC Electrical Characteristics: ($V_S = \pm 15\text{V}$, $0^\circ \leq T_A \leq +70^\circ\text{C}$, $T_{HIGH} = +70^\circ\text{C}$ unless otherwise specified)

Parameter	Symbol	Test Conditions	Min	Typ	Max	Unit
Input Offset Voltage	V_{OS}	$R_S = 50\Omega$, $T_A = +25^\circ\text{C}$	–	3	10	mV
		Over Temperature	–	–	13	mV
Average TC of Input Offset Voltage	$\Delta V_{OS}/\Delta T$	$R_S = 50\Omega$	–	5	–	$\mu\text{V}/^\circ\text{C}$
Change in Average TC with V_{OS} Adjust	$\Delta\text{TC}/\Delta V_{OS}$	$R_S = 50\Omega$, Note 3	–	0.5	–	$\mu\text{V}/^\circ\text{C}$
Input Offset Current	I_{OS}	$T_J = +25^\circ\text{C}$, Note 4	–	3	50	pA
		$T_J \leq T_{HIGH}$	–	–	2	nA
Input Bias Current	I_B	$T_J = +25^\circ\text{C}$, Note 4	–	30	200	pA
		$T_J \leq T_{HIGH}$	–	–	8	nA
Input Resistance	R_{IN}	$T_J = +25^\circ\text{C}$	–	10^{12}	–	Ω
Large Signal Voltage Gain	A_{VOL}	$T_A = +25^\circ\text{C}$, $V_O = \pm 10\text{V}$, $R_L = 2\text{k}$	25	200	–	V/mV
		Over Temperature	15	–	–	V/mV
Output Voltage Swing	V_O	$R_L = 10\text{k}$	± 12	± 13	–	V
		$R_L = 2\text{k}$	± 10	± 12	–	V
Input Common-Mode Voltage Range	V_{CM}		± 10	+15.1 –12	–	V
Common-Mode Rejection Ratio	CMRR		–	80	100	dB
Supply Voltage Rejection Ratio	PSRR	Note 5	–	80	100	dB

Note 3. The temperature coefficient of the adjust input offset voltage changes only a small amount ($0.5\mu\text{V}/^\circ\text{C}$ typically) for each mV of adjustment from its original unadjusted value. Common-mode rejection and open loop voltage gain are also unaffected by offset adjustment.

Note 4. The input bias currents are junction leakage currents which approximately double for every 10°C increase in the junction temperature, T_J . Due to limited production test time, the input bias currents measured are correlated to junction temperature. In normal operation the junction temperature rises above the ambient temperature as a result of internal power dissipation, P_d . $T_J = T_A + R_{thJC} P_d$ where R_{thJC} is the thermal resistance from junction to ambient. Use of a heat sink is recommended if input bias current is to be kept to a minimum.

Note 5. Supply Voltage Rejection is measured for both supply magnitudes increasing or decreasing simultaneously, in accordance with common practice.

AC Electrical Characteristics: ($T_A = +25^{\circ}\text{C}$, $V_S = \pm 15\text{V}$ unless otherwise specified)

Parameter	Symbol	Test Conditions	Min	Typ	Max	Unit	
Slew Rate	SR	$A_V = 5$	30	50	–	$\text{V}/\mu\text{s}$	
Gain Bandwidth Product	GBW		–	20	–	MHz	
Settling Time to 0.01%	t_s	Note 6	–	1.5	–	μs	
Equivalent Input Noise Voltage	e_N	$R_S = 100\Omega$	$f = 100\text{Hz}$	–	15	–	$\text{nV}/\sqrt{\text{Hz}}$
			$f = 1000\text{Hz}$	–	12	–	$\text{nV}/\sqrt{\text{Hz}}$
Equivalent Input Current Noise	i_N	$f = 100\text{Hz}$	–	0.01	–	$\text{pA}/\sqrt{\text{Hz}}$	
		$f = 1000\text{Hz}$	–	0.01	–	$\text{pA}/\sqrt{\text{Hz}}$	
Input Capacitance	C_{IN}		–	3	–	pF	

Note 6. $A_V = -5$, the feedback resistor from output to input is $2\text{k}\Omega$ and the output step is 10V .

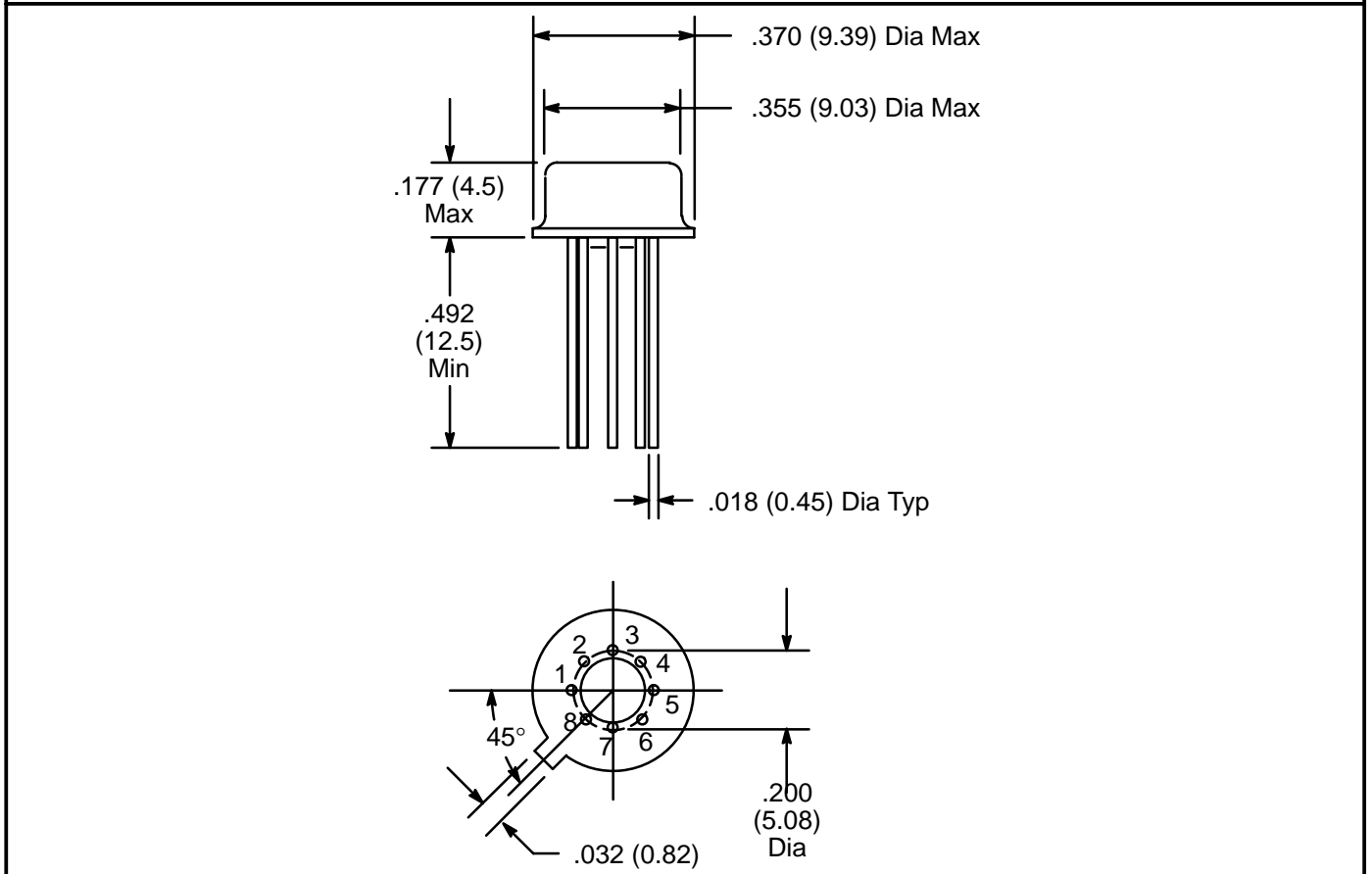
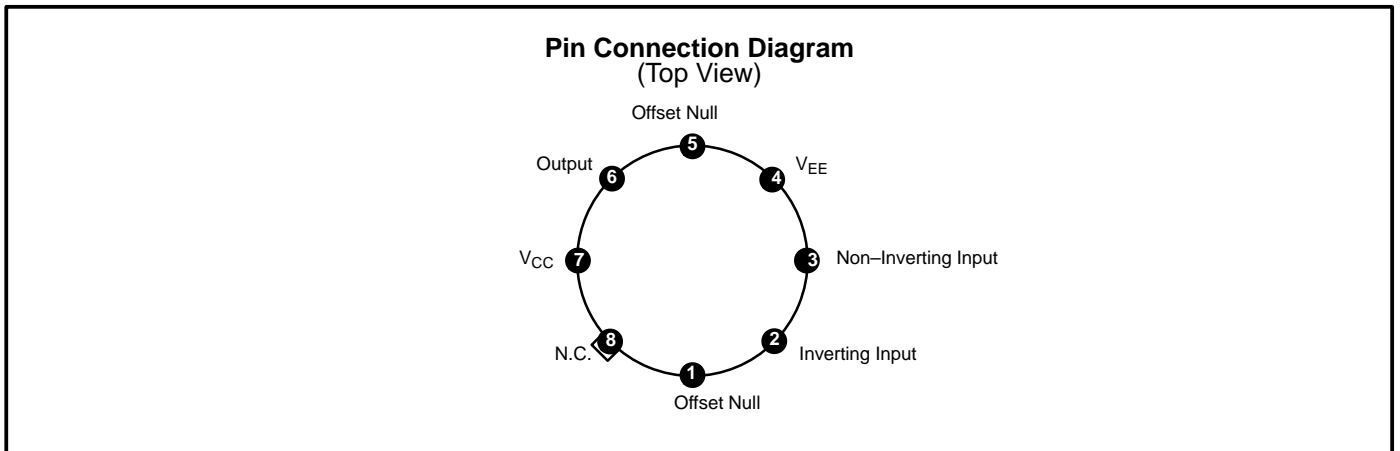

X-ON Electronics

Largest Supplier of Electrical and Electronic Components

Click to view similar products for [Operational Amplifiers - Op Amps](#) category:

Click to view products by [NTE manufacturer](#):

Other Similar products are found below :

[OPA2991IDSGR](#) [OPA607IDCKT](#) [007614D](#) [633773R](#) [635798C](#) [635801A](#) [702115D](#) [709228FB](#) [741528D](#) [NCV33072ADR2G](#) [SC2903DR2G](#)
[SC2903VDR2G](#) [LM258AYDT](#) [LM358SNG](#) [430227FB](#) [430228DB](#) [460932C](#) [AZV831KTR-G1](#) [409256CB](#) [430232AB](#) [LM2904DR2GH](#)
[LM358YDT](#) [LT1678IS8](#) [042225DB](#) [058184EB](#) [070530X](#) [714228XB](#) [714846BB](#) [873836HB](#) [MIC918YC5-TR](#) [TS912BIYDT](#)
[NCS2004MUTAG](#) [NCV33202DMR2G](#) [M38510/13101BPA](#) [NTE925](#) [SC2904DR2G](#) [SC358DR2G](#) [LM358EDR2G](#) [AZV358MTR-G1](#)
[AP4310AUMTR-AG1](#) [HA1630D02MMEL-E](#) [NJM358CG-TE2](#) [HA1630S01LPEL-E](#) [LM324AWPT](#) [HA1630Q06TELL-E](#) [NJM4558CG-TE2](#)
[AZV358MMTR-G1](#) [SCY33178DR2G](#) [NCS4325DR2G](#) [LM7301SN1T1G](#)