



ELECTRONICS, INC.  
 44 FARRAND STREET  
 BLOOMFIELD, NJ 07003  
 (973) 748-5089  
<http://www.nteinc.com>

## NTE945 Integrated Circuit Operational Amp

**Description:**

The NTE945 is a precision, high input impedance operational amplifier in an 8-Lead Metal Can type package designed for applications requiring extremely low input current errors. This device uses supergain transistors in a Darlington input stage to get input bias currents that are equal to high-quality FET amplifiers—even in limited temperature range operation.

Unlike most other internally compensated amplifiers, the MOS compensation capacitor is protected to prevent catastrophic failure from overvoltage spikes on the supplies.

The low current error of this amplifier makes possible many designs that were previously impractical with monolithic amplifiers. It will operate from 100mΩ source resistances, introducing less error than general purpose amplifiers with 10kΩ sources, Integrators with worst case drifts less than 10μV/sec and analog time delays in excess of one day can also be made using capacitors no larger than 1μF.

**Features:**

- Guaranteed Bias Currents as Low as 50pA
- Maximum Offset Currents Down to 15pA
- Operates from Supplies of ±3V to ±20V
- Supply Current Only 300μA at ±20V

**Absolute Maximum Ratings:**

|   |                |
|---|----------------|
| Supply Voltage                            | ±20V           |
| Power Dissipation (Note 1)                | 500mW          |
| Differential Input Current (Note 2)       | ±10mA          |
| Input Voltage (Note 3)                    | ±15V           |
| Output Short-Circuit Duration             | Indefinite     |
| Operating Temperature Range               | 0° to +70°C    |
| Storage Temperature Range                 | -65° to +150°C |
| Lead Temperature (Durin Soldering, 10sec) | +300°C         |

Note 1. The maximum junction temperature is +70°C. For operating at elevated temperatures, the NTE945 must be derated based on a thermal resistance of +150°C/W, junction-to-ambient, or +45°C/W, junction-to-case.

Note 2. The inputs are shunted with back-to-back diodes for overvoltage protection. Therefore, excessive current will flow if a differential input voltage in excess of 1V is applied between the inputs unless some limiting resistance is used.

Note 3. For supply voltages less than ±15V, the absolute maximum input voltage is equal to the supply voltage.

**Electrical Characteristics:** ( $T_A = -0^\circ$  to  $+55^\circ\text{C}$ ,  $\pm 5\text{V} \leq V_S \leq \pm 20\text{V}$  unless otherwise specified)

| Parameter                      | Test Conditions   | Min                       | Typ | Max | Unit             |      |
|--------------------------------|---|---------------------------|-----|-----|------------------|------|
| Input Offset Voltage           | $T_A = +25^\circ\text{C}$   | -                         | -   | 10  | mV               |      |
|                                |   | -                         | -   | 15  | mV               |      |
| Input Offset Current           | $T_A = +25^\circ\text{C}$   | -                         | -   | 50  | pA               |      |
|                                |   | -                         | -   | 100 | pA               |      |
| Input Bias Current             | $T_A = +25^\circ\text{C}$   | -                         | -   | 150 | pA               |      |
|                                |   | -                         | -   | 250 | pA               |      |
| Input Resistance               | $T_A = +25^\circ\text{C}$   | 1                         | -   | -   | $\text{G}\Omega$ |      |
| Supply Current                 | $T_A = +25^\circ\text{C}$   | -                         | -   | 0.8 | mA               |      |
| Large Signal Voltage Gain      | $V_S = \pm 15\text{V}$ , $V_{\text{OUT}} = \pm 10\text{V}$ ,<br>$R_L \geq 10\text{k}\Omega$ | $T_A = +25^\circ\text{C}$ | 20  | -   | -                | V/mV |
|                                |   |                           | 15  | -   | -                | V/mV |
| Output Voltage Swing           | $V_S = \pm 15\text{V}$ , $R_L = 10\text{k}\Omega$   | $\pm 13$                  | -   | -   | V                |      |
| Input Voltage Range            | $V_S = \pm 15\text{V}$  | $\pm 13$                  | -   | -   | V                |      |
| Common Mode Rejection Ratio    |   | 80                        | -   | -   | dB               |      |
| Supply Voltage Rejection Ratio |   | 80                        | -   | -   | dB               |      |

**Pin Connection Diagram**  
(Top View)

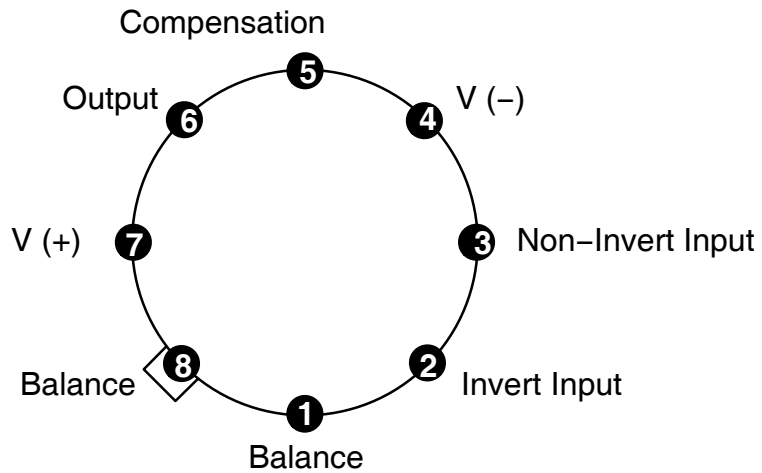

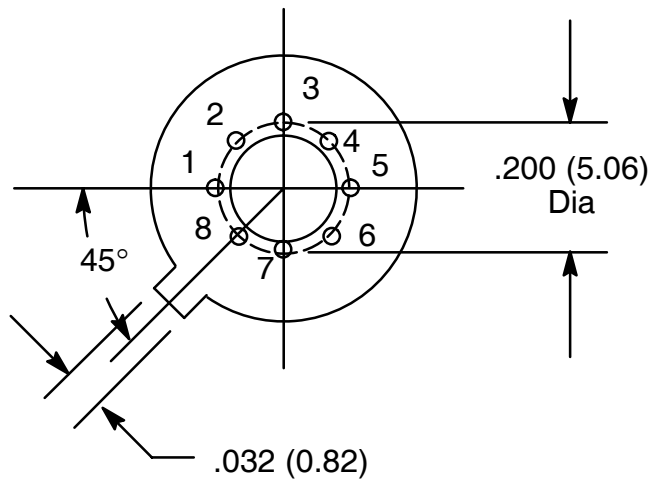
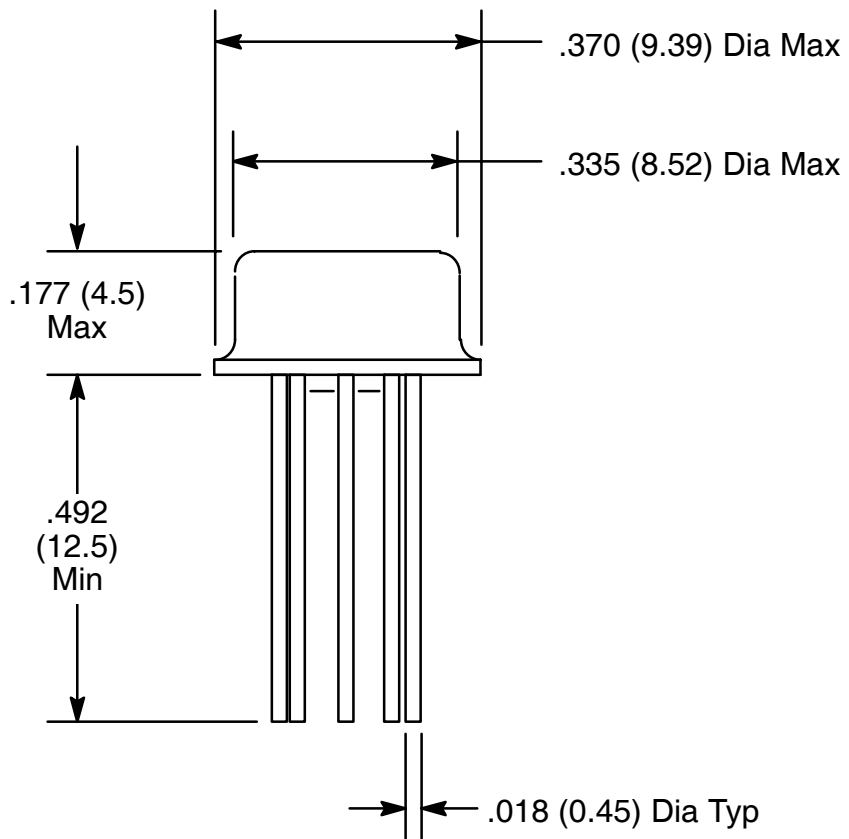

## X-ON Electronics

Largest Supplier of Electrical and Electronic Components

*Click to view similar products for [Operational Amplifiers - Op Amps category](#):*

*Click to view products by [NTE manufacturer](#):*

Other Similar products are found below :

[OPA2991IDSGR](#) [OPA607IDCKT](#) [007614D](#) [633773R](#) [635798C](#) [635801A](#) [702115D](#) [709228FB](#) [741528D](#) [NCV33072ADR2G](#) [SC2903DR2G](#)  
[SC2903VDR2G](#) [LM258AYDT](#) [LM358SNG](#) [430227FB](#) [430228DB](#) [460932C](#) [AZV831KTR-G1](#) [409256CB](#) [430232AB](#) [LM2904DR2GH](#)  
[LM358YDT](#) [LT1678IS8](#) [042225DB](#) [058184EB](#) [070530X](#) [714228XB](#) [714846BB](#) [873836HB](#) [MIC918YC5-TR](#) [TS912BIYDT](#)  
[NCS2004MUTAG](#) [NCV33202DMR2G](#) [M38510/13101BPA](#) [NTE925](#) [SC2904DR2G](#) [SC358DR2G](#) [LM358EDR2G](#) [AZV358MTR-G1](#)  
[AP4310AUMTR-AG1](#) [HA1630D02MMEL-E](#) [NJM358CG-TE2](#) [HA1630S01LPEL-E](#) [LM324AWPT](#) [HA1630Q06TELL-E](#) [NJM4558CG-TE2](#)  
[AZV358MMTR-G1](#) [SCY33178DR2G](#) [NCS4325DR2G](#) [LM7301SN1T1G](#)