



ELECTRONICS, INC.
 44 FARRAND STREET
 BLOOMFIELD, NJ 07003
 (973) 748-5089
<http://www.nteinc.com>

NTE987/NTE987SM Integrated Circuit Quad, Low Power OP Amp

Description:

The NTE987 and NTE987SM are low cost quad operational amplifiers with true differential inputs. These have several distinct advantages over standard operational amplifier types in single supply applications. The quad amplifier can operate at supply voltages as low as 3V or as high as 32V with quiescent currents about one fifth of those associated with the NTE941 (on a per amplifier basis). The common mode input range includes the negative supply, thereby eliminating the necessity for external biasing components in many applications. The output voltage range also includes the negative power supply voltage.

Features:

- Available in 14-Lead DIP (NTE987) and Surface Mount, SOIC-14 (NTE987SM)
- Short Circuit Protected Outputs
- True Differential Input Stage
- Single Supply Operation: 3V to 32V
- Four Amplifiers per Package
- Internally Compensated
- Common Mode Range Extends to Negative Supply
- Industry Standard Pin-Outs

Absolute Maximum Ratings: ($T_A = +25^\circ\text{C}$ unless otherwise specified)

Power Supply Voltages	
Single Supply, V_{CC}	32V
Split Supplies, $V_{CC} V_{EE}$	$\pm 16\text{V}$
Input Differential Voltage Range (Split Power Supplies), V_{IDR}	$\pm 32\text{V}$
Input Common Mode Voltage range, V_{ICR}	-0.3 to 32V
Input Forward Current ($V_I < 0.3\text{V}$, Note 1), I_{IF}	50mA
Output Short Circuit Duration, t_S	Continuous
Operating Junction Temperature, T_J	$+150^\circ\text{C}$
Operating Ambient Temperature Range, T_A	0° to $+70^\circ\text{C}$
Storage Temperature Range, T_{stg}	-55° to $+125^\circ\text{C}$

Note 1. This input current will only exist when the voltage is negative at any of the input leads. Normal output states will reestablish when the input voltage returns to a voltage greater than -0.3V.

Electrical Characteristics: ($V_{CC} = 5V$, $V_{EE} = GND$, $T_A = +25^\circ C$ unless otherwise specified)

Parameter	Symbol	Test Conditions	Min	Typ	Max	Unit	
Input Offset Voltage	V_{IO}	$V_{CC} = 5V$ to $30V$, $V_{ICR} = 0$ to $V_{CC}-1.7V$, $V_O = 1.4V$, $R_S = 0\Omega$	$T_A = 0$ to $+70^\circ C$	-	2	7	mV
				-	-	9	mV
Average Temperature Coefficient of Input Offset Voltage	$\Delta V_{IO}/\Delta T$	$T_A = 0$ to $+70^\circ C$	-	7	-	$\mu V/^\circ C$	
Input Offset Current	I_{IO}		-	5	50	nA	
		$T_A = 0$ to $+70^\circ C$	-	-	150	nA	
Average Temperature Coefficient of Input Offset Current	$\Delta I_{IO}/\Delta T$	$T_A = 0$ to $+70^\circ C$	-	10	-	$pA/^\circ C$	
Input Bias Current	I_{IB}		-	-90	-250	nA	
		$T_A = 0$ to $+70^\circ C$	-	-	-500	nA	
Input Common-Mode Voltage Range	V_{ICR}	$V_{CC} = 30V$		0	-	28.3	V
			$T_A = 0$ to $+70^\circ C$	0	-	28.0	V
Differential Input Voltage Range	V_{IDR}		-	-	V_{CC}	V	
Large Signal Open-Loop Voltage Gain	A_{VOL}	$R_L = 2k\Omega$, $V_{CC} = 15V$, For Large V_O Swing		25	100	-	V/mV
			$T_A = 0$ to $+70^\circ C$	15	-	-	V/mV
Channel Separation		$1kHz \leq f \leq 20kHz$, Input Referenced	-	-120	-	dB	
Common-Mode Rejection Ratio	CMRR	$R_S \leq 10k\Omega$	65	70	-	dB	
Power Supply Rejection Ratio	PSRR		65	100	-	dB	
Output Voltage Range	V_{OR}	$R_L = 2k\Omega$	0	-	3.3	V	
Output Voltage - High Limit	V_{OH}	$V_{CC} = 30V$, $T_A = 0$ to $+70^\circ C$	$R_L = 2k\Omega$	26	-	-	V
			$R_L = 10k\Omega$	27	28	-	V
Output Voltage - Low Limit	V_{OL}	$V_{CC} = 5V$, $R_L = 10k\Omega$, $T_A = 0$ to $+70^\circ C$	-	5	20	mV	
Output Source Current	I_{Source}	$V_{ID} = 1V$, $V_{CC} = 15V$		20	40	-	mA
			$T_A = 0$ to $+70^\circ C$	10	20	-	mA
Output Sink Current	I_{Sink}	$V_{ID} = -1V$, $V_{CC} = 15V$		10	20	-	mA
			$T_A = 0$ to $+70^\circ C$	5	8	-	mA
			$V_{ID} = -1V$, $V_O = 200mV$	12	50	-	μA
Output Short Circuit to GND	I_{os}	Note 3	-	40	60	mA	
Power Supply Current	I_{CC}	$V_O = 0$, $R_L = \infty$, $T_A = 0$ to $+70^\circ C$	$V_{CC} = 30V$	-	-	3.0	mA
			$V_{CC} = 5V$	-	-	1.2	mA

Note 2. The input common-mode voltage or either input signal voltage should not be allowed to go negative by more than 0.3V. The upper end of the common-mode voltage range is $V_{CC}-1.7V$, but either or both inputs can go to +32V without damage.

Note 3. Short circuits from the output to V_{CC} can cause excessive heating and eventual destruction. Destructive dissipation can result from simultaneous shorts on all amplifiers.

Pin Connection Diagram

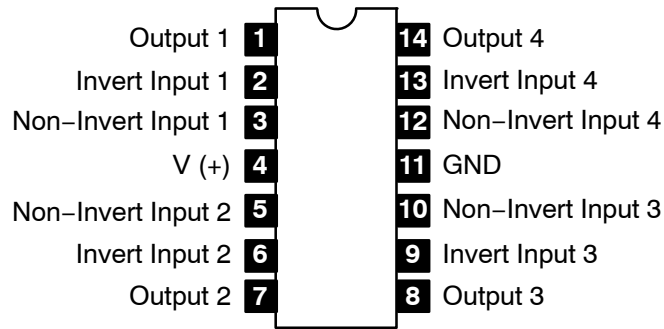

NTE987

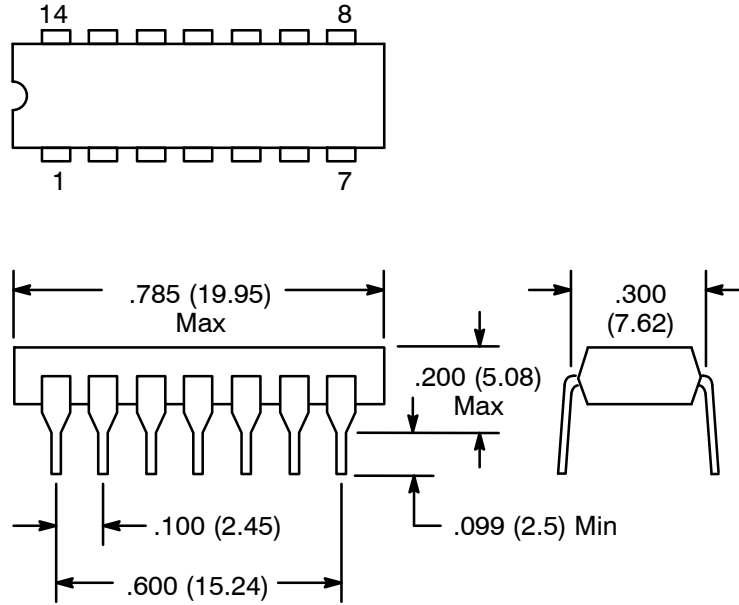

NTE987SM

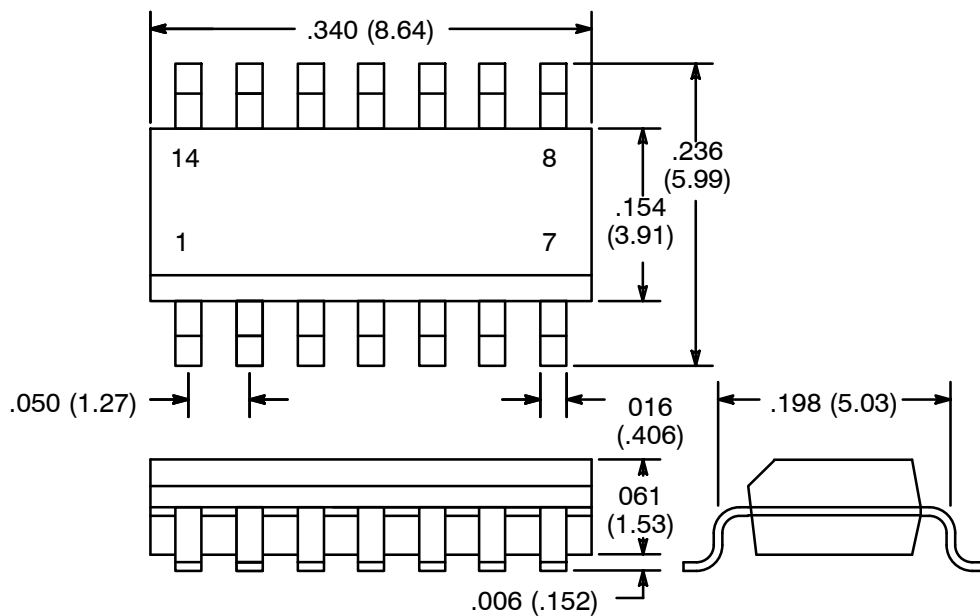

NOTE: Pin1 on Beveled Edge

X-ON Electronics

Largest Supplier of Electrical and Electronic Components

Click to view similar products for [Operational Amplifiers - Op Amps category](#):

Click to view products by [NTE manufacturer](#):

Other Similar products are found below :

[OPA2991IDSGR](#) [OPA607IDCKT](#) [007614D](#) [633773R](#) [635798C](#) [635801A](#) [702115D](#) [709228FB](#) [741528D](#) [NCV33072ADR2G](#) [SC2903DR2G](#)
[SC2903VDR2G](#) [LM258AYDT](#) [LM358SNG](#) [430227FB](#) [430228DB](#) [460932C](#) [AZV831KTR-G1](#) [409256CB](#) [430232AB](#) [LM2904DR2GH](#)
[LM358YDT](#) [LT1678IS8](#) [042225DB](#) [058184EB](#) [070530X](#) [714228XB](#) [714846BB](#) [873836HB](#) [MIC918YC5-TR](#) [TS912BIYDT](#)
[NCS2004MUTAG](#) [NCV33202DMR2G](#) [M38510/13101BPA](#) [NTE925](#) [SC2904DR2G](#) [SC358DR2G](#) [LM358EDR2G](#) [AZV358MTR-G1](#)
[AP4310AUMTR-AG1](#) [HA1630D02MMEL-E](#) [NJM358CG-TE2](#) [HA1630S01LPEL-E](#) [LM324AWPT](#) [HA1630Q06TELL-E](#) [NJM4558CG-TE2](#)
[AZV358MMTR-G1](#) [SCY33178DR2G](#) [NCS4325DR2G](#) [LM7301SN1T1G](#)